

**EFFICACY OF NAL-NL1 PRESCRIPTION
FOR THE FIRST-TIME HEARING AID USERS:
A FOLLOW-UP STUDY**

Register No.: 06AUD001

A Dissertation Submitted in Part Fulfillment of
Final year M.Sc (Audiology)
University of Mysore, Mysore.

**ALL INDIA INSTITUTE OF SPEECH AND HEARING
MANASAGANGOTRI, MYSORE - 570 006
April 2008**

*Dedicated to
my Parents....*

*Who gave me this precious
gift, called Life....*

&

Babaji and Nanaji....

*Who taught me the real
meaning of Life....*

CERTIFICATE

This is to certify that this dissertation entitled "*Efficacy of NAL-NLI prescription for the first-time hearing aid users: A follow-up study*" is the bonafide work submitted in part fulfillment for the degree of Master of Science (Audiology) of the student with registration no. 06AUD001. This has been carried out under the guidance of a faculty of this institute and has not been submitted earlier to any other University for the award of any other Diploma or Degree.

Mysore

April, 2008



Dr. Vijayalakshmi Basavaraj

Director

All India Institute of Speech and Hearing

Manasagangothri,

Mysore-570 006

CERTIFICATE

This is to certify that the dissertation entitled "*Efficacy of NAL-NLI prescription for the first-time hearing aid users: A follow-up study*" has been prepared under my supervision and guidance. It is also certified that this has not been submitted earlier in any other University for the award of any Diploma or Degree.

Mysore

April, 2008

Guide
Manjula P.
15.4.08

Ms. Manjula P.
Lecturer
Department of Audiology
All India Institute of Speech and Hearing
Manasagangothri
Mysore -570006

DECLARATION

This is to certify that this dissertation entitled “*Efficacy of NAL-NLI prescription for the time hearing aid users: A follow up study*” is the result of my own study under the guidance of Ms. P Manjula, Lecturer, Department of Audiology, All India Institute of Speech and Hearing, Mysore, and has not been submitted in any other University for the award of any Diploma or Degree.

Mysore

April, 2008

Register No. 06AUD001

ACKNOWLEDGMENT

Behind every successful project there stand a myriad of people whose help and contribution make it a success. I, hereby, extend my heartfelt thanks to all those, who, directly or indirectly, helped me sail through the tough times and encouraged me in their own ways to undertake and complete this dissertation.

It would be extremely unfair to start the note of thanks without mentioning my guide, Ms. P. Manjula, whose untiring efforts saw me to the end of this project. I'll always wonder what the source of your endless energy is. My heartfelt gratitude for bearing with me ma'm.

I acknowledge Dr. V. Basavaraj, Director, AIISH, for permitting me to conduct this study.

Also, I'd like to thank the HoD, Audiology, Prof. Asha Yathiraj, and ex HoD, Dr. K. Rajalakshmi, for granting us permission to use the department, even on the weekends and holidays. Of course, special thanks to Sujeet sir, and Baba... for spoiling their weekends and spending time in the dept while we collected data.

Statistics has never been my strength, and it was some heroic efforts from Vasanthalakshmi ma'm, which untangled the puzzle of my 'thesis-like' data, and helped me overcome the 'mathematical obstacles'. Thanks is a word too small for you ma'm... You are truly SPSS.. Sedate- Practical-Sagacious-Suave...!! Thanks a lot for spending hours in helping with the statistics.

Special thanks to Ms. Muthuselvi, Dept. of Electronics, for furnishing the client details on time.

I also take this opportunity to thank all the participants of my study, without whose cooperation this study was impossible.

My gratitude is also due for all my teachers whose painstaking efforts and guidance has helped me reach this level.

Sincere thanks to the library staff and Mr. Shivappa, for helping me at all the odd hours and at the last minute notice.

It is said that 'when you die, if you've five real friends you've had a great life.' I was lucky enough to find all five of them here in AIISH.... Chandu, Leah (Chatori), Anjana, Manuj, Neha (Putamma)... time spent in your company made my stay at AIISH worthwhile. . Be in touch Always...

Also, the members of our Triphthi bakery 'Bak' gang.. Neha Asthana, Rupali, Priyanka and Krupha.. Our outings and parties are memories to treasure.. Wish you guys all the best for your future.

Acknowledgments will be incomplete if I don't make a mention of my partners in crime, my internship batch 'AIIMS- The Always Intimate Internmates'.. Anagha (Moti), Balaji (Triple X), Chithra (Laati), Hema (Gucci), Pratiksha (Bandri) and myself (Dabba)... I had the best time of my life in your company. . during internship and even after that..Those memories are firmly etched in my heart.. We'll surely plan a re-union of AIIMS.

Biswajeet, Sushmi, Sindhu, Pragati..., always had fun in your company.. thanks for being around and providing the much needed moral support.

Not to forget, the small family that I've at AIISH, Nikhil, Priya, Gurdeep, and of course my daughter Achu/ Anu / Raxy (Its one person's different names!!)...My good wishes will always be with all of you. Thanks Raxy.. for sacrificing your 'work-outs' and 'movies' while I used 'our' laptop (We call him Lappy...!!).

I always believed that good things should come in the end; so lastly, I'd like to thank my family... Mummy, Papa, Bhabhi, Dada, Jiji, Jijaji, and the cutest children on earth...Abeer and Teena.. My life is meaningless without you all.. I'd also like to thank my uncles..Anil chacha, Bhaiya chacha, Ashoo chacha.. and my aunts.. Anita chachi, Seema chachi and Shilpa chachi.. It's your blessings and encouragement that always keeps me ticking.

I thank the Almighty for giving me the Best Family; help me find the Best of friends and. an opportunity to study in the Best Institute by The Best Teachers. Thank you Lord for Everything...!!!

TABLE OF CONTENTS

Chapter	Title	Page No.
1	INTRODUCTION	1
2	REVIEW OF LITERATURE	6
3	METHOD	17
4	RESULTS AND DISCUSSION	30
5	SUMMARY AND CONCLUSION	61
	REFERENCES	65
	APPENDIX A	<i>i</i>
	APPENDIX B	<i>ii</i>

LIST OF TABLES

Table	Title	Page No.
Table 4.1	Mean and Standard Deviation (SD) of aided thresholds with the three hearing aid programs (P1, P2, & P3) at different frequencies for moderate, moderately severe and severe hearing loss groups	33
Table 4.2	Programs which differ significantly from each other at various frequencies for the group with moderate hearing loss	36
Table 4.3	Programs which differed significantly from each other at various frequencies for the group with moderately severe hearing loss	38
Table 4.4	Programs which differed significantly from each other at various frequencies for the group with severe hearing loss	40
Table 4.5	Mean and Standard Deviation (SD) of aided SRS across three hearing aid programs (P1, P2, & P3) for Moderate, Moderately Severe and Severe hearing loss groups	41
Table 4.6	Programs which differed significantly from each other for SRS in moderate, moderately severe and severe hearing loss groups	42
Table 4.7	Mean and Standard Deviation (SD) of aided UCL across three hearing aid programs (P1, P2, & P3) for Moderate, Moderately Severe and Severe hearing loss groups	44
Table 4.8	Mean and Standard Deviation (SD) of REIG with three hearing aid programs (P1, P2, & P3) for three groups of participants	46
Table 4.9	Programs which differed significantly in REIG at different frequencies for the group with severe hearing loss	51
Table 4.10	Mean and Standard Deviation of RESR across three hearing aid programs (P1, P2, & P3) for Moderate, Moderately Severe and Severe hearing loss groups	53
Table 4.11	Programs which differed significantly from each other on RESR at various frequencies for the group with severe hearing loss	56

LIST OF FIGURES

Figure	Title	Page No.
Figure 3.1	Position of participant and the loud speaker for real ear testing	25
Figure 3.2	Illustration of the measurement of probe tube length for REUG and REAG	25
Figure 3.3	Illustration for measurement of insertion gain (REIG)	27
Figure 4.1	Average Aided Thresholds (AT) for the group with moderate hearing loss for P1, P2, and P3 at different frequencies	34
Figure 4.2	Average aided thresholds for the group with moderately severe hearing loss for P1, P2, and P3 at each tested frequency	37
Figure 4.3	Average aided thresholds for group with severe hearing loss for P1, P2, and P3 at different frequencies	39
Figure 4.4	Average aided SRS for P1, P2, and P3 across the three groups of participants	43
Figure 4.5	Average aided UCL for P1, P2, and P3 across the three groups of participants.	44
Figure 4.6	Average REIG for group with moderate hearing loss for P1, P2, and P3 at tested frequencies	47
Figure 4.7	Average REIG for group with moderately severe hearing loss for P1, P2, and P3 at different frequencies	48
Figure 4.8	Average REIG for group with severe hearing loss for P1, P2, and P3 at tested frequencies	50
Figure 4.9	Average RESR for group with moderate hearing loss for P1, P2, and P3 at different frequencies	54
Figure 4.10	Average RESR for group with moderately severe hearing loss for P1, P2, and P3 at different frequencies	55
Figure 4.11	Average RESR for group with severe hearing loss for P1, P2, and P3 at different frequencies	57

Chapter 1

INTRODUCTION

A prescriptive approach to hearing aid fitting is one in which the amplification characteristics are calculated from some of the hearing characteristics of an individual. This is based on the assumption that certain amplification characteristics suit certain types, degrees and configurations of hearing loss (Byrne, 1986). There are several prescriptive procedures for hearing aid selection, some for linear hearing aids such as Prescription Of Gain and Output (POGO), National Acoustic Laboratories formula-Revised (NAL-R) and some for non-linear hearing aids such as Desired Sensation Level-input/output (DSL-i/o), Figure 6 (FIG6), NAL Non Linear-1 (NAL-NL1).

Prescriptive approaches to hearing aid selection and fitting have been very frequently used by audiologists since early 1980s, although they have enjoyed an even longer history among hearing aid dispensers and manufacturers, for example, the “½ gain rule” (Byrne, 1986; Humes, 1996). Throughout the 1980s, a myriad of prescriptive rationales emerged, and several studies and detailed analyses were conducted subsequently to examine the differences among them (Byrne, 1986, 1987; Humes, 1986, 1991; Humes & Hackett, 1990; Humes & Halling, 1994; McCandless, 1994). In general, more similarities were observed among the approaches than differences, especially when the limitations of the available circuit choices and practical fitting constraints, such as electro-acoustic feedback, were taken into consideration. Based on recent surveys of clinical practices in the U.S. (Martin, Armstrong, & Chaplin, 1994; Martin, Chaplin, & Chambers, 1998), it appears that those approaches having the greatest amount of

validating data to support them while concurrently requiring a minimum amount of measurements by the audiologists from the prospective hearing aid wearer (i.e., hearing thresholds only) have emerged as the most common prescriptive methods.

The first prescriptive formula by National Acoustic Laboratories (NAL) was published in 1976 (Byrne & Tonnison, 1976). NAL is a threshold-based prescription of the gain-frequency response for linear hearing aids that aims at maximizing speech intelligibility. The procedure is based on three principles, viz. preferred insertion gain at 1 kHz equals 0.46 times the loss at 1 kHz, speech bands according to the long-term average speech spectrum should be perceived equally loud, and equal loudness at a most comfortable level is modeled using the 60-phon equal loudness contour curve by listeners with normal hearing.

As its predecessor, NAL, NAL-R (Byrne & Dillon, 1986) is a threshold-based procedure for prescribing the gain-frequency response in linear hearing aids with the aim of maximizing speech intelligibility. Evaluation of the first NAL formula showed that it did not achieve equal loudness of speech bands for all types of hearing loss. In particular, empirical data showed that the shape of the gain-frequency response varied 0.31 times the shape of the audiogram rather than the 0.46 times implemented in NAL. Further, when the hearing loss reached the severe and profound level, hearing aid users wanted 0.66 times, rather than 0.46 times, more gain per dB of loss, which gave way to the development of NAL-RP (NAL-Revised, Profound).

NAL-NL1 evolved as a compression based method for non-linear hearing aids in 1998, from the older NAL-R method for linear hearing aids. The NAL-NL1 fitting method presents with some other interesting features, which are based in part, on the

original underlying philosophy of the whole NAL “family” of fitting methods (NAL, NAL-R, NAL-RP). This includes *equalization*, rather than *normalization* (preservation) of the loudness relationships among the speech frequencies. The reason the NAL-NL1 method deviates from the approach of preserving the unaided loudness relationships among the different frequency elements of speech is because the “preserving” approach has not been shown to improve speech intelligibility (Dillon, Byrne, Ching, Katsch, Keidser & Brewer, 2000).

Like all compression based fitting methods, NAL-NL1 has more than one target, because hearing aid compression offers different gain for different input levels. The main objective of developing NAL-NL1 was to determine the gain for several input levels that would result in maximal effective audibility. Also NAL-NL1 provides lesser gain for frequencies where hearing loss is worst and more gain where hearing is best. This point is developed further in literature describing the development of NAL-NL1, where the term “audibility” is differentiated from the term “effective audibility” (Dillon, et al., 2000).

According to Keidser, and Dillon (2006), NAL-NL1 aims to maximize speech intelligibility for any input level above the compression threshold, while keeping the overall loudness at or below normal. It is derived from an optimization procedure combining the Speech Intelligibility Index formula (SII, modified) and a loudness model of Moore, and Glasberg (1997). Keidser, and Dillon (2006) also stated that NAL-NL1 produces gain-frequency responses that makes loudness of speech bands approximately constant across frequency, and at medium levels agrees with NAL-RP

“Audibility” can be described and measured in terms of sensation level, if actual hearing thresholds are known. “Effective audibility”, on the other hand, refers to the

extent of information that can be extracted from speech sounds once they are audible. According to Dillon, et al. (2000), as hearing loss increases, people tend to have more “effective audibility” with less audibility. Even with all these optimizations incorporated, clinically it is seen that the gain preferred by individual clients is different from that prescribed by NAL-NL1.

Need for the study

A question that might come to mind is whether the hearing aid users appreciate and accept the hearing aid that is programmed to NAL-NL1 targets. Can a user always accept the levels that would theoretically maximize their speech intelligibility?

Killion, and Revit (1993) have cautioned that even accurate calculations, carefully computed coupler transfer functions, and rigid standards of manufacturing the hearing aid may not yield the perfect results when measured on an individual probe microphone. In an experiment that NAL has conducted, Keidser and Dillon (2006) have investigated the extent to which the gain preferred by adult hearing aid wearers changes over time. The extent proved to be considerably smaller than most clinicians believe. Possibly the widespread belief that new hearing aid users need considerably less gain than experienced users has in part arisen because many prescription procedures, including NAL-NL1, provide somewhat more gain than even experienced hearing aid wearers prefer, i.e., Keidser and Dillon (2006) reported that NAL-NL1 was too loud as reported by the first time hearing aid users.

NAL-NL1 is one of the most widely used generic prescriptive procedures for the non-linear hearing aids. However, owing to the above-mentioned factors, it becomes

mandatory for an audiologist to plunge into the depths of various factors affecting the success of hearing aid fitment, and prescribe hearing aid with a program that is optimized to a particular client to give maximum benefit, and not just depend on the target amplification, which is based on average data.

Objectives of the study

The present study aims at evaluating the efficacy with which NAL-NL1 prescribes the hearing aid parameters for persons with varying types and degrees of hearing loss. It also aims at finding out the changes observed in the preferred amplification parameters by the hearing aid users after the first 6 to 8 weeks of hearing aid fitment, and how much they deviate from the target curve prescribed by NAL-NL1.

Chapter 2

REVIEW OF LITERATURE

Most Behind-The-Ear hearing aids fitted today are programmable, digital, and the dispensing audiologists are required to program these instruments according to established prescriptive fitting methods, such as DSL4.1, NAL-NL1. The reason for programming the hearing aids to a given prescriptive method is that substantial research has indicated that this fitting philosophy is most appropriate for the average patient, given that patient's specific audiometric characteristics. Most appropriate can mean maximizing speech intelligibility, obtaining superior speech quality, restoring normal loudness perceptions, or some combination of these or other factors. Given the multiple settings required in today's hearing aids for gain, output, and compression that need to be determined in several channels for varying input levels, it is necessary to have an automated starting point for the hearing aid fitting.

The question then becomes, are these prescriptive fitting targets a reasonable starting point for the average patient? Whether there should be a difference between the first and final fit is related in part to the manufacturers' and dispenser's beliefs concerning the patient's acclimatization, adaptation, adjustment, and auditory learning to hearing aid use.

Stelmachowicz, Dalzell, Peterson, Kopun, Lewis, and Hoover (1998) compared the gains for 50 and 80 dB SPL input levels prescribed by DSL [i/o], FIG6 and a proprietary algorithm to the gain preferred by subjects wearing a two channel, wide dynamic range compression hearing aid. DSL [i/o] over prescribed gain at 500, 2000 and

4000 Hz at both input levels. FIG6 under prescribed gain for mild and moderate hearing losses, particularly at the 80 dB input level, but over-prescribed gain for severe to profound losses.

The proprietary, threshold based formula more accurately prescribed the gain used. This is not too surprising, as the proprietary formula was a statistical summary of the gains actually used by wearers of precisely this type of hearing aid. It is possible, however, that the gains used by the subjects were influenced by the gains they were fitted with, which in turn were influenced by the proprietary fitting formula.

Keidser and Grant (2001) compared the performance of IHAF (Independent Hearing Aid Fitting Forum) with NAL-NL1 using a two channel hearing aid. The purpose of the study was to compare the benefit obtained from loudness normalization procedure (IHAF) with speech intelligibility maximization (NAL-NL1). Twenty-four subjects (eight for each of three groups of mild flat, moderate/severe flat and steeply sloping hearing loss) participated in the study. Each subject completed an initial laboratory test, a field test, and a final laboratory test. The laboratory test consisted of a paired-comparison judgment for each prescriptive formula using four stimuli under both quiet and noisy listening conditions and a sentence recognition test using Bamford-Kowal-Bench sentences. In the field test, the subjects evaluated the two rationales in individually selected everyday listening conditions for four weeks. A digital simulation of the fitting rationales implemented in two channels was used for laboratory testing and a digital 2-memory, 2-channel device was used for field testing. Subjects adjusted the overall gain of each response to their preferred listening level in both the laboratory and in the field.

Data collected in the laboratory before and after the field test showed no indication of significant learning or acclimatization effects. For each stimulus presented in the paired-comparison test, more subjects preferred NAL-NL1 than preferred IHAFF. For the sentence recognition test, subjects performed significantly better with NAL-NL1 than IHAFF in a low-frequency weighted background noise. Sixteen out of 22 subjects who completed the field test reported a preference for the NAL-NL1 response. The remaining six subjects preferred IHAFF. The paired-comparison test and field test revealed that while the achieved root-mean-square (rms) difference between the fittings for an input level of 65 dB SPL was small, the preference for either rationale was small. As the rms difference between the fittings increased, the score in favour of NAL-NL1 increased. The correlation between the differences in satisfaction score obtained in the field test and the rms differences between the responses fitted was statistically significant.

When the two fitting rationales prescribed substantially different responses for a 65 dB SPL input and these differences were achieved in the fitting, then the subjects preferred NAL-NL1. Even when the difference between fittings was small, the subjects preferred and performed better with NAL-NL1 when listening in a low-frequency weighted background noise.

However, contrary to the above finding of no effect of learning, or acclimatization effects, clinical experience indicates that the first time users prefer less gain than predicted by generally expected prescription rules (Leijon, Eriksson-Mangold & Bech-Karlsen, 1984).

In a later study by Leijon, Lindkvist, Ringhdahl, and Israelsson (1990) involving mainly the first time users, and also some subjects with previous although rather limited

experience of hearing aids, they confirmed the fact that the preferred gain was less than prescribed, but saw no correlation between time of previous hearing aid use and the recommended versus preferred gain differences. However, no data were given on the extent of hearing aid experience.

The hypothesis that first time hearing aid users prefer less gain and lower maximum output levels, was tested on 20 subjects being fitted with their first hearing aids by Arlinger, Lyregaard, Billemark and Oberg (2000). This study was double blinded by using a programmable hearing aid, set to either the standard setting according to the manufacturer's software or to reduce gain and maximum output. Half of the subjects started with one hearing aid and half with the other, changing to the other hearing aid after three days trial with each setting.

At the end of the study, subjects stated preference in specified situations and overall. No significant differences in APHAB (Abbreviated Profile of Hearing Aid Benefit), sound quality, estimated communication ability or perceived loudness scores were seen for the two settings. Nine subjects preferred the standard setting, seven the reduced setting and four were undecided. No correlation could be found between preference and audiological variables based on this study.

While there are prescriptive approaches that have been validated, in recent years it has become popular to deviate from validated methods and use manufacturer's proprietary algorithms, which in many cases are significantly different. Mueller (2004) reviewed eleven studies to examine if there was evidence supporting the use of specific gain requirements for hearing aid fitting. Specifically, the question that was asked was

“Are there real-world outcome measures from adult patients that show a preference for the gain prescribed by a specific prescriptive fitting procedure?”

In this study, inclusion criteria were: adult subjects, use of consistent technology (different prescriptive method compared using same hearing aids), real ear verification of gain, and real-world outcome measures.

The National Acoustic Laboratories’ revised (NAL-R), revised for severe/profound (NAL-RP), and the National Acoustic Laboratories-Non-Linear 1 (NAL-NL1) prescriptive methods were used as a common reference, as they have been the most commonly studied methods with adults.

Eight of the eleven studies supported gain similar to that prescribed by the NAL-R or NAL-RP methods; three studies supported prescribed gain less than NAL-R or NAL-RP. There was no evidence that gain greater than that prescribed by the NAL methods should be used. However, it is important to point out that the evidence presented here relates only to adults with mild to moderate hearing loss. It is probable that the severe to profound hearing loss group has different gain requirements.

Most prescriptive methods for non-linear, wide dynamic range compression (WDRC) hearing aids are based on the assumption that a listener with hearing impairment should perceive amplified sounds at the same overall loudness as would a listener with normal-hearing without amplification. However, some previous research on linear amplification has indicated that subjects prefer less overall gain than prescribed by the most commonly used prescriptive method for linear hearing aids, NAL-R, a method that gives close to normal overall loudness for a mid-level input.

This study by Smedz (2004), however, aims at comparing two prescriptive methods for WDRC hearing aids. The methods differ in the overall loudness they aim to give the hearing aid user. One method, called NormLoudn, is based on a generic method that prescribes gain so that the overall loudness is restored to normal. Another method, called LessLoudn, is based on a hearing aid specific prescription, and gives the hearing aid user less than normal overall loudness. It was the aim of this study to find out if the first-time hearing aid users prefer the method that restores overall loudness to normal or the method that gives less than normal overall loudness.

Twenty-one first-time hearing aid users with typical hearing losses for this group of clients participated in a crossover blinded field study where the two fitting methods were compared using a multi-programmable hearing aid. Preference in the field was evaluated using interview, questionnaire, and diary. The field test was accompanied by laboratory tests, which included paired comparison judgments of preference and loudness and a speech recognition test. Loudness calculations were also used when interpreting the results and a theoretical comparison with other prescriptive methods for WDRC hearing aids was made.

After necessary adjustments, the measured gain for the two methods was similar in gain-frequency shape, but NormLoudn gave more overall gain than LessLoudn. Generally, NormLoudn fittings led to calculated overall loudness that was close to normal, whereas LessLoudn fittings, in median, led to 3-7 phon less than normal calculated overall loudness according to the loudness model used. During the interview performed after the field test, 19 out of the 21 subjects stated that they preferred LessLoudn. Also the questionnaire and the diary showed a clear preference for

LessLoudn in all types of listening situations. Paired comparisons of preference in the laboratory supported the findings in the field. LessLoudn was preferred to NormLoudn in all tested situations, except for soft speech in very soft noise where there was no significant preference for either method. Speech recognition scores were similar for the two fittings. The difference in calculated loudness was clearly distinguishable to the subjects and seemed to govern their preferences.

LessLoudn, which gave less than normal overall loudness according to the loudness model used, was preferred both in the field and in the laboratory tests. Speech recognition scores were similar for both methods. A comparison between the measured gain for NormLoudn and the gain prescribed by Cambridge Method for loudness Equalization (CAMEQ), NAL-NL1, and DSL[i/o], suggested that all three prescriptive procedures (DSL[i/o] in particular) would probably overestimate the required gain for subjects without hearing aid experience and with mild to moderate hearing loss.

On similar lines, review of the 14 papers was conducted to determine the validity of the belief that new users of hearing aids prefer lower gain levels than experienced hearing aid users and that new user will gradually come to prefer higher gain levels over time (Convery, Keidser & Dillon, 2005). The audiometric data for 175 subjects, for whom use gain was measured at various intervals post-fitting, was divided into 'new' (N=98) and 'experienced' (N=77) groups. For each of these subjects, the NAL-R target was calculated and the prescribed gain was compared to the use gain. An analysis of these data suggested that there was no difference between the gain preferences of new and experienced hearing aid users, nor did the gain preferences of new users change over the first 12 months of hearing aid use.

Keidser, Convery, and Dillon (2002) investigated if clients prefer less overall gain than prescribed by NAL-NL1 when wearing a commercial device in their everyday environments. Forty-eight clients (86 ears) attending three hearing centers in South Australia were fitted with the LS 16 (Bernafon's Smile), which is a digital, two-memory, two-channel wide dynamic range compression hearing aid. These clients were originally invited to evaluate the multi-memory feature of the device.

All clients were fitted according to the NAL-NL1 formula in program 1. The hearing aid was initially adjusted to simulated target curves in the fitting software and then verified by real-ear measurements against the NAL-RP target using a 65 dB speech shaped noise as input. The NAL-RP target was used in the verification process because the NAL-NL1 target was not available in the analyzing equipment used by the participating hearing centers. During the fitting appointment, the focus was on the alternative program to ensure that the client was fitted with audibly different amplification characteristics in the two programs. The clients were then carefully instructed about the purpose of each program, where the NAL-NL1 fit was presented as a general-purpose program.

At a review appointment scheduled about four weeks post-fitting the two programs were fine tuned, if needed, according to the client's experience with the two programs in their real-life environments. The audiologists were free to adjust the overall gain as well as the frequency response shape as required. Real-ear measurements were obtained of the final settings from which the preferred three-frequency average gain (500, 1000, and 2000 Hz), the preferred low-frequency average gain (250, and 500), and the preferred high-frequency average gain (2000, 3000, and 4000 Hz) were calculated. The

preferred average gain settings were then compared with the average NAL-NL1 prescription for a 65 dB speech input, which for each individual was obtained from the NAL-NL1 standalone software. Gain settings at frequencies where the NAL-NL1 formula suggested no gain were extrapolated by using a gain roll-off of 6 dB per octave.

The clients returned to the hearing centre four months later to fill in a questionnaire about their experience with the device and the two programs. In the questionnaire, the clients, among other things, estimated the percentage of time each of the two programs was used and rated how helpful they found NAL-NL1 in general listening situations on a scale from 1 (no help at all) to 10 (very helpful). The middle of the rating scale (5) was labeled somewhat helpful. To obtain information from a much larger group of subjects (albeit very indirectly), surveys were e-mailed to Australian Hearing clinicians via a hierarchical e-mail distribution route within the Australian Hearing e-mail system. The number of clinicians who received the e-mail is not known, but responses were obtained from 39 clinicians. Clinicians were asked to estimate the proportion of clients for whom they had to increase the gain away from the NAL-NL1 prescription, the proportion for which a decrease was necessary, and the proportion for which the gain was “just right”. They were asked to provide this information separately for clients at the time they were first fitted and for clients after they had been wearing the hearing aid(s) for a few weeks.

On average, the clients preferred 0.70 dB, 0.53 dB, and 1.54 dB less gain than prescribed overall, in the low frequencies, and in the high frequencies, respectively. There was some spread in the data, particularly when higher gain levels are prescribed and for the high-frequency band. The data suggest that a few subjects preferred

substantially more high frequency gain than that prescribed by NAL-NL1. This could be because the gain initially was adjusted to the NAL-RP target rather than the NAL-NL1 target with the client accepting the extra gain prescribed by NAL-RP relative to NAL-NL1 in the high frequencies. It should also be noted that gain settings shown as preferred lower gain could be a result of preference or could be a result of some limitation in gain adjustment due to vented moulds or feedback. Overall, these data do not support the claim that NAL-NL1 prescribes too much overall gain for a 65 dB SPL input.

However, as average values were taken which may have been less due to cancellation of the effect because of the heterogeneous participant group, results might have been conclusive had they analyzed the results in different types and degrees of hearing loss.

Clinicians reported that for most clients, it was not necessary to vary the gain away from the NAL-NL1 prescription, either at the first fitting or subsequently. Where a change was needed, it was much more likely that the clinician would decrease the gain rather than increase it. This differential was more marked on the day the fitting was made than at follow-up some weeks later. The data, however, were not sufficiently detailed to determine whether any gain changes necessary reflect inappropriate gain at low, medium and/or high input levels, nor at low-, mid-, and/or high- frequencies.

Deviating from the traditional 'preference studies', Palmer (2001) studied the impact of hearing loss and hearing aid experience on sound quality judgments. The purpose of this experiment was to quantify potential differences in sound quality judgments from individuals with normal hearing, hearing loss but no hearing aid experience, and hearing loss with hearing aid experience.

Subjects with normal hearing (15), subjects with hearing loss but no hearing aid experience (15), and subjects with binaural hearing aid experience (15) rated the sound quality (0 to 100%) of continuous discourse recordings made with three binaural sets of hearing aids. The hearing aids represented a range of coherence function values from perfect coherence (assumed excellent sound quality) to poor coherence (assumed poor sound quality) with two input levels (70 and 90 dB SPL).

The groups with normal hearing, with hearing impairment, and with hearing-impairment but no hearing aid experience revealed identical sound quality preferences at the 90 dB SPL input level that were consistent with the physical measure of sound quality. These two groups did not show a particular preference for either soft or loud input levels, whereas, the experienced hearing aid users rated sound quality significantly higher for the loud input level regardless of type of hearing aid and sound quality as defined by the physical measurement.

Chapter 3

METHOD

This study was conducted to evaluate the deviations in gain parameter from that prescribed by NAL-NL1 after a period of hearing aid use.

Participants

The study included twenty participants in the age range from 45 to 80 years (mean age being 60.9 years). The participants were divided into groups based on the degree of hearing loss and type of hearing loss.

A. Based on degree of hearing loss in the aided ear, three groups were formed, which were:

<i>Groups</i>	<i>Grouping Criteria</i>
Group A1 (N=5)	Participants with a Pure Tone Average (PTA) of 35 to 55 dB HL
Group A2 (N=8)	Participants with a Pure Tone Average (PTA) of 56 to 70 dB HL
Group A3 (N=7)	Participants with a Pure Tone Average (PTA) of 71 to 90 dB HL

B Based on type of hearing loss in the aided ear, two groups were formed:

<i>Group</i>	<i>Grouping Criteria</i>
Group B1 (N=12)	Mixed hearing loss (Bone conduction thresholds >15 dB; ABG = 15 to 40 dB HL)
Group B2 (N=8)	Sensori-neural hearing loss (ABG < 10 dB)

All the participants were first-time hearing aid users and had no previous experience of hearing aid use. The data were collected after they used the hearing aid for a period of at least 45 days to six months. All the participants had post-lingual onset of hearing loss, with duration of hearing loss not greater than five years, and spoke Kannada fluently. All the participants of the study used only digital BTE hearing aid monaurally. The aided thresholds with the selected hearing aid programmed for these individuals were within the speech spectrum.

Instruments

The following instruments were used:

- A calibrated two channel sound field audiometer with two loud speakers to perform the aided sound field testing. The loud speakers were located at 0⁰ Azimuth and 180⁰ Azimuth; at a distance of 1 meter from the participant. A personal computer was connected to the auxiliary input of the audiometer for presentation of speech material through a CD.
- Personal computer with Hi-Pro, NOAH 3 and hearing aid fitting softwares for programming the digital hearing aid.
- A calibrated hearing aid analyzer for performing the insertion gain measurements.
- A questionnaire for fine tuning of hearing aid, fitting assistant questionnaire (given in Appendix A).
- Participant's own hearing aid was used for the study. All the three models of the hearing aid were manufactured by the same company and had the features as mentioned below:

- A two channeled fully digital hearing aid suitable for hearing loss from mild to profound degree, with three programmable memories, Automatic Gain Control - Input (AGC-I) compression and output limiting

or

- A two channeled fully digital hearing aid suitable for moderate to severe degree of hearing loss, with three programmable memories, AGC-I compression and output limiting

or

- A single channeled fully digital hearing aid with two frequency bands, suitable for hearing loss of moderate to severe degree, with three programmable memories, AGC-I compression and output limiting

Speech Material

Recorded phonemically balanced Kannada bi-syllabic word lists on a CD, developed by Yathiraj, and Vijayalakshmi (2005) were used. Four out of the eight lists in the test material were used. Each of the lists had 25 bi-syllabic words. Each list consisted of all the speech sounds in Kannada. The four lists are given in Appendix B.

Test Environment

The testing was carried out in a two room sound treated environment in which the ambient noise levels were within permissible limits.

Procedure

The procedure was carried out in three phases for each participant. They were:

Phase I: Programming the participant's own hearing aid

Phase II: Measurement using subjective tests

A: Aided hearing threshold

B: Aided Speech Recognition Score (SRS)

C: Aided Uncomfortable level (UCL)

Phase III: Measurement using objective tests

A: Real Ear Insertion Gain (REIG)

B: Real Ear Saturation Response (RESR)

Phase I: Programming the Participant's Own Hearing Aid

For each of the participant, his/her own hearing aid model was programmed in three different settings as three different programs. The three hearing aid programs were:

- a. ***NAL-NLI setting***: This is the program which was generated as 'first fit' by the hearing aid fitting software. 'First fit' settings were obtained by using the NAL-NLI prescriptive formula, and the participant's hearing thresholds. This was stored in Program 1 (herein after referred to as P1).
- b. ***Participant's preferred setting***: This was the modified program, modified at the time of hearing aid dispensing as per the participant's needs. The settings that were noted in the scoring sheet at the time of trial (before hearing aid prescription) were used for this purpose. This was saved in Program 2 (herein after referred to as P2).

c. ***Fine tune setting:*** The hearing aid program was modified based on a 'Fitting Assistant Questionnaire', designed specifically for hearing aid fitment. This was used to fine tune the hearing aid after a minimum of 45 days of hearing aid use. This program was stored in Program 3 (herein after referred to as P3).

The hearing aid programs P1, P2, and P3 were manipulated on all or a few of the following setting parameters depending on the features available in the hearing aid:

1. Maximum Gain (MG)
2. Gain for first frequency band (G1)
3. Low cut frequency (LC)
4. Gain for the second frequency band (G2)
5. High cut frequency (HC)
6. Compression knee-point for the first and second frequency band (CK1 & CK2 respectively)
7. Crossover Frequency (CF) and
8. Compression Ratio for the first and second frequency band (CR1 & CR2 respectively).

Acclimatization level was kept at a constant value of two for the above mentioned programs, viz., P1, P2 and P3.

Testing was then carried out with the other two phases with each of the above mentioned programs. Both objective and subjective measurements were performed with each of the programs for ten out of 20 participants. For the rest of the participants

(10/20), only subjective testing was done. All the testing were done using participant's own hearing aid and custom ear mould.

Phase II: Measurement Using Subjective Tests

The subjective tests were carried out to measure the aided thresholds, Speech Recognition Scores (SRS), and Uncomfortable Level (UCL) in the three aided conditions (P1, P2, and P3).

II A. Aided hearing thresholds

- The aided thresholds in sound field were measured for Frequency Modulated (5% frequency modulation) tones at 250 Hz, 500 Hz, 750 Hz, 1 kHz, 2 kHz, 3 kHz, 4 kHz and 6 kHz.
- The tones were presented through the loud speaker located at 0° Azimuth and 1 meter distance from the participants.
- Bracketing method was used to arrive at the threshold.
- The participants were instructed to indicate the presence of the tone, and to respond by raising the forefinger of the right hand even to the faintest tone heard by them.
- The lowest level in dB HL at each frequency was noted as the aided threshold, with each program setting (P1, P2, P3). This was done for each participant and the aided thresholds were tabulated.

II B. Aided Speech Recognition Scores (SRS)

- The participants were seated in the calibrated position in the sound field with the speech material being presented through the loudspeaker positioned in front at 0° Azimuth at a distance of 1 meter.
- The recorded word list was played through windows media player in the computer and was routed through the auxiliary input of the audiometer to the loudspeaker. The VU meter deviation was monitored to ensure that it did not exceed an average deflection of 0 dB on the scale.
- Care was taken to ensure that there was no effect of the order of the word list on SRS.
- The participant was instructed to repeat the words that he/she heard.
- The presentation level was kept constant at 45 dB HL. It was ensured that this level was within the UCL of the participant.
- Responses were scored on a response sheet as the number of words correctly identified. The maximum score was 25 as the list consisted of 25 words. The SRS was measured separately for each participant with the hearing aid programmed in three settings (P1, P2, and P3).

II C. Aided Uncomfortable Level (UCL)

- Speech noise was presented through the loud speaker.
- The level of speech noise was increased systematically from 45 dB HL in 5 dB steps.

- The participant was instructed to indicate the level at which the noise presented was uncomfortably loud. The instruction was to indicate a level at which the speech noise was uncomfortable and no longer tolerable to the participant.
- The procedure was repeated two times. The average of highest values at which he/she could tolerate the noise was noted as the UCL, for each setting (P1, P2, P3), for each participant.

Thus, the aided thresholds, SRS, and UCL were established in each program setting (P1, P2, and P3) for all the 20 participants.

Phase III. Measurement using Objective Tests

Real ear measurements were carried out to evaluate the following, in each of the three hearing aid programs (P1, P2, P3) for ten participants.

III.A. Real Ear Insertion Gain (REIG)

REIG, as defined by ANSI (1997), is the difference in decibels as a function of frequency, between the Real Ear Aided Gain (REAG) and the Real Ear Unaided Gain (REUG), obtained with the same measurement point and the same sound field conditions.

Before the actual testing started, leveling of the probe system of the hearing aid analyzer instrument was done using the reference microphone placed above the ear as shown in Figure 3.1 to ensure a smooth frequency output from the real ear analyzer.

Protocol for REIG: REIG was obtained by subtracting the REUG from REAG. The participant was seated at one foot distance and 45⁰ Azimuth from the loudspeaker of the real ear analyzer.

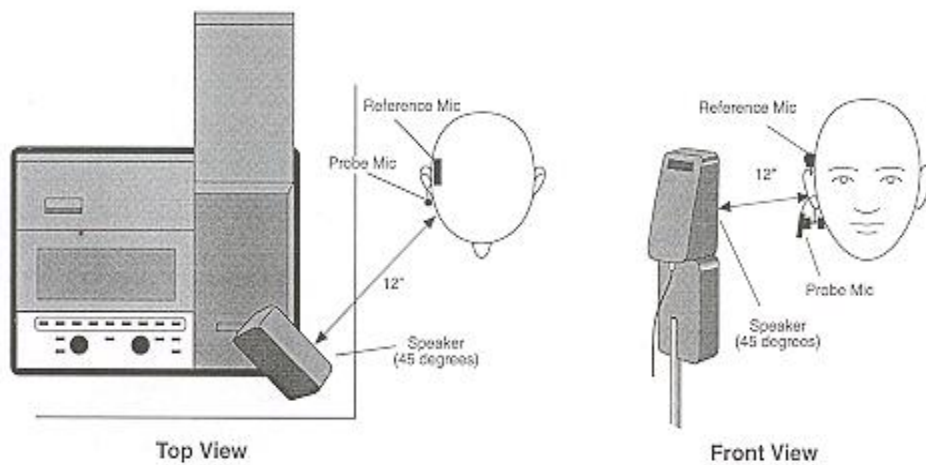
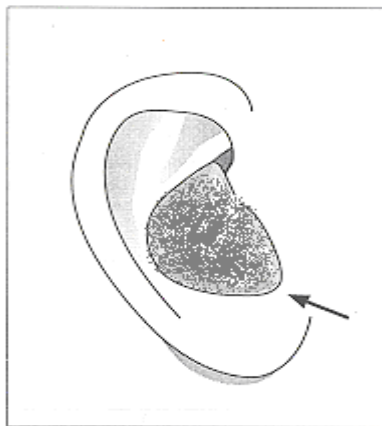

Fig. 3.1: Position of participant and the loud speaker for real ear testing

Measurement of REUG

- To ensure proper insertion depth of the probe tube, the probe tube was placed in the ear canal, so that the tube rested along the bottom of the canal part of the ear mold, with the tube extending at least 5 mm (1/5 inch) past the ear mold.



Alignment of the bottom of the ear mold with the ear to observe the part which touches the inter-tragal notch

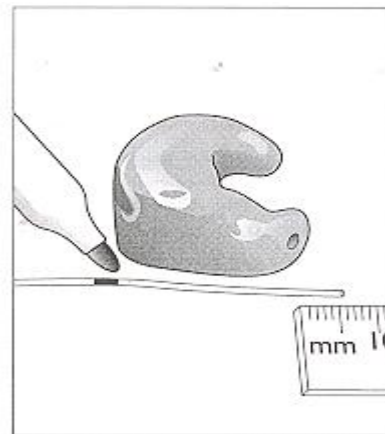

A reference mark on the probe tube

Fig. 3.2: Illustration of the measurement of probe tube length for REUG and REAG

- Target curve was created in the real ear analyzer by entering the audiometric data in the instrument and selecting the NAL prescriptive procedure.

Protocol

- Type of stimulus: International Collegium for Rehabilitative Audiology (ICRA, a temporally modulated) digital speech signal.
 - Level of stimulus: 60 dB SPL for REUG, REAG, and
90 dB SPL for RESR.
 - Reference microphone: On
 - Smoothing: Off
 - Output limit: 125 dB SPL
 - Test type: Insertion Gain
- The probe tube microphone in the unaided ear canal picked up and measured the sound in the unoccluded ear canal. The Real Ear Unaided Gain (REUG) was measured and displayed as dB at different frequencies.

Measurement of REAG

- Probe tube was placed in the ear canal, so that the tube rested along the bottom of the canal part of the ear mold, with the tube extending at least 5 mm (1/5 inch) past the canal opening as explained in the REUG measurement.
- The hearing aid was fitted into the participant's ear while holding the probe tube so that its position in the ear canal was not disturbed.
- Hearing aid was turned 'on'.



Location of the reference microphone and probe tube microphone for REUR

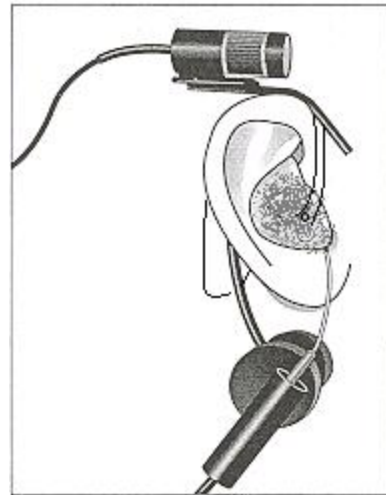

Location of reference microphone and probe tube microphone along with the hearing aid for REAR

Fig. 3.3: Illustration for measurement of insertion gain (REIG)

Protocol

- Type of stimulus: ICRA speech signal
 - Level of stimulus: 60 dB SPL
 - Reference microphone: On
 - Smoothing: Off
 - Output limit: 125 dB SPL
 - Test type: Insertion Gain
- The probe tube microphone measured the dB SPL in the ear canal as delivered by the hearing aid. The Real Ear Aided Gain (REAG) was displayed as a curve with frequency versus dB.

REIG

- The real ear analyzer automatically displayed the REIG across frequencies. This was done by the instrument, by subtracting the REUG from the REAG.
- The values of REIG were noted down from the data table at 200 Hz, 500 Hz, 700 Hz, 1 kHz, 1.5 kHz, 2 kHz, 3 kHz, 4 kHz, 6 kHz, and 8 kHz, in each program setting (P1, P2, and P3), for each participant.

III B. Real Ear Saturation Response (RESR)

- Location of the participant and the loud speaker of the hearing aid analyzer was same as that for REIG
- The placement of probe tube in the ear canal and the hearing aid was same as that for REAG
- The volume of the hearing aid was set to the highest position just before feedback or projected use setting.

Protocol

- Type of stimulus: ICRA speech signal
- Level of stimulus: 90 dB SPL
- Reference microphone: On
- Smoothing: Off
- Test type: SPL

- The probe tube microphone measured the dB SPL in the ear canal as delivered by the hearing aid. The Real Ear Saturation Response (RESR) was displayed as a curve with frequency versus dB SPL.
- Values of RESR were noted down from the data table at 200 Hz, 500 Hz, 700 Hz, 1 kHz, 1.5 kHz, 2 kHz, 3 kHz, 4 kHz, 6 kHz, and 8 kHz for each program setting (P1, P2, and P3) for each participant.

Thus, the REIG and RESR were noted down for each of the ten participants, at three different hearing aid program settings, i.e., Program 1 (P1), Program 2 (P2), and Program 3 (P3).

Chapter 4

RESULT AND DISCUSSION

To evaluate the objectives of the study, data were collected using both subjective tests and objective tests. These data were collected with the hearing aid set in three different programs, P1 (Participant's preferred setting at the time of purchase of hearing aid), P2 (NAL-NL1 setting), and P3 (Fine tune settings based on fine tune assistant). The participants were from broad categories A and B, based on degree of hearing loss and type of hearing loss respectively.

The data from the subjective tests included:

1. Aided thresholds for frequency modulated tones at frequencies 250 Hz, 500 Hz, 750 Hz, 1 kHz, 1.5 kHz, 2 kHz, 3 kHz, 4 kHz & 6 kHz.
2. Speech Recognition Scores (SRS)
3. Uncomfortable level (UCL) using speech noise.

The data from the objective tests included measurements using hearing aid analyzer for frequencies 200 Hz, 500 Hz, 700 Hz, 1 kHz, 1.5 kHz, 2 kHz, 3 kHz, 4 kHz, 6 kHz, and 8 kHz:

1. Real ear insertion gain, and
2. Real ear saturation response.

Statistical Package for Social Sciences, SPSS (version 15) was used for analysis of the data. To examine if there was any difference between these groups of participants an independent samples t-test was run initially. The results revealed no significant

difference between performance of sensori-neural and mixed hearing loss groups, hence these two groups were considered as a homogenous group for the rest of the study.

Independent samples t-test was again run for the groups of participants with different degrees of hearing loss and the three groups were found to be statistically different for a few frequencies. Based on this result, the three sub-groups with different degrees of hearing loss have been considered separately for statistics. For all the sub-groups considered henceforth, Friedman's test was done initially to check if there was any significant difference between the three programs (P1, P2 & P3). If a significant difference existed, then Wilcoxon's test was administered to know which of the three programs differed significantly from each other.

The results are discussed under the following headings for the subjective tests:

4.1 Aided thresholds

4.1.1 Group with moderate hearing loss

4.1.2 Group with moderately severe hearing loss

4.1.3 Group with severe hearing loss

4.2 SRS

4.3 UCL

The results of the objective tests are discussed under the following headings:

4.4 REIG

4.4.1 Group with moderate hearing loss

4.4.2 Group with moderately severe hearing loss

4.4.3 Group with severe hearing loss

4.5 RESR

4.5.1 Group with moderate hearing loss

4.5.2 Group with moderately severe hearing loss

4.5.3 Group with severe hearing loss

Further, the results of subjective and objective tests were compared. Comparison was made between:

4.6 Aided threshold and REIG & SRS

4.7 UCL and RESR

4.1 Aided Thresholds

Mean and standard deviation (SD) of the aided thresholds revealed variations in the aided thresholds across the three programs and across the frequencies tested as shown in Table 4.1. Results have been discussed separately for the moderate, moderately severe and severe groups. For all the groups of participants, the aided thresholds for the lower frequencies were better and became progressively poorer at the higher frequencies in all the three hearing aid programs. This can be attributed to the greater hearing loss usually seen at higher frequencies than at the lower frequencies and also to the inability of the hearing aids to provide more amplification at the higher frequencies.

Table 4.1: Mean and Standard Deviation (SD) of aided thresholds with the three hearing aid programs (P1, P2, & P3) at different frequencies for moderate, moderately severe and severe hearing loss groups

Freq. (Hz)	Prog.	<i>Groups based on severity of hearing loss</i>					
		<i>Moderate</i>		<i>Moderately severe</i>		<i>Severe</i>	
		<i>Mean</i>	<i>S.D.</i>	<i>Mean</i>	<i>S.D.</i>	<i>Mean</i>	<i>S.D.</i>
250	P1	27.00	7.58	33.75	5.18	35.00	4.08
	P2	27.00	4.47	34.38	7.76	29.29	7.87
	P3	23.00	4.47	31.25	6.41	26.43	3.78
500	P1	27.00	4.47	34.38	4.96	35.00	4.08
	P2	29.00	2.24	35.63	3.20	32.86	8.09
	P3	24.00	2.24	32.50	2.67	31.43	3.78
750	P1	28.00	2.74	34.38	4.17	37.86	3.93
	P2	30.00	7.91	38.13	3.72	38.57	9.45
	P3	27.00	2.74	32.50	2.67	33.57	5.56
1000	P1	30.00	3.54	37.50	4.63	41.43	6.90
	P2	33.00	2.74	40.00	4.63	43.57	8.02
	P3	29.00	4.18	35.63	4.17	37.14	6.36
1500	P1	30.00	3.54	40.00	5.35	43.57	6.90
	P2	30.00	6.12	42.50	2.67	42.86	8.59
	P3	32.00	6.71	38.75	4.43	39.29	5.35
2000	P1	33.00	5.70	36.25	6.41	43.57	11.07
	P2	38.00	2.74	40.63	3.20	47.14	11.13
	P3	34.00	5.48	38.13	5.94	39.29	8.38
3000	P1	37.00	7.58	42.50	8.02	43.57	14.92
	P2	42.00	2.74	45.63	3.20	45.00	14.43
	P3	36.00	6.52	42.50	8.45	40.71	10.58
4000	P1	43.00	8.37	46.88	8.43	48.57	21.55
	P2	45.00	6.12	50.00	3.78	51.43	20.76
	P3	37.00	9.75	46.88	3.72	45.71	14.56
6000	P1	48.00	11.51	55.00	5.35	68.57	34.73
	P2	58.00	9.75	55.00	5.35	68.57	26.73
	P3	47.00	14.41	52.50	3.78	65.00	27.54

4.1.1 Group with Moderate Hearing Loss

As can be noted from Figure 4.1, the aided threshold with the fine tune program (P3) always resulted in better (lower) thresholds (except at 1.5 kHz), than the NAL-NL1 program (P2), thus proving that NAL-NL1 program did not always give the lowest possible aided threshold and that fine tuning of the program was necessary to get better results from the hearing aid for the group with moderate hearing loss.

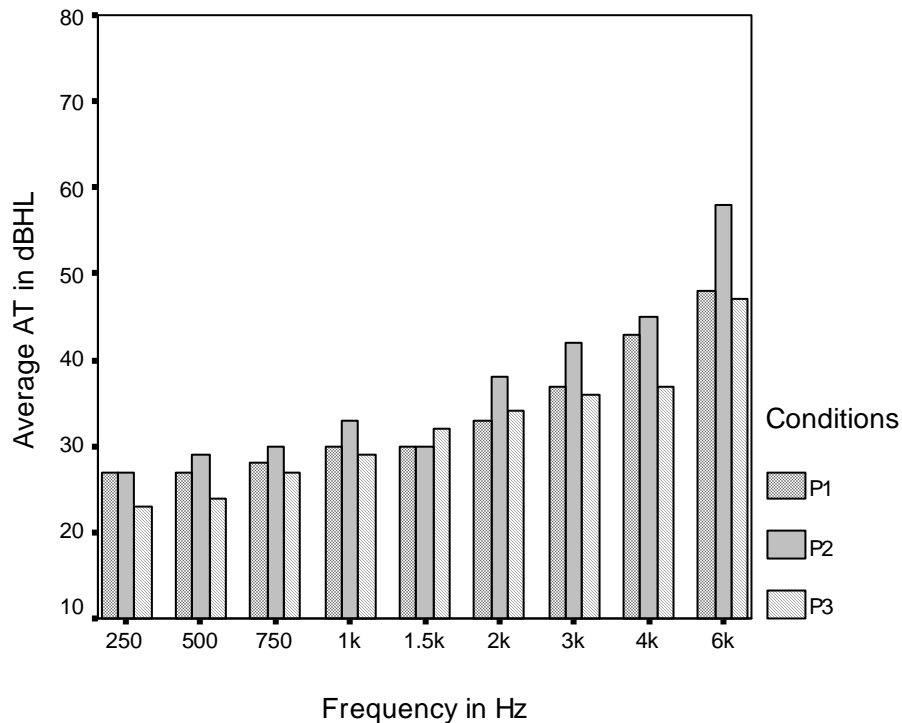

Fig. 4.1: Average Aided Thresholds (AT) for the group with moderate hearing loss for P1, P2, and P3 at different frequencies

On comparison of aided thresholds with programs 1, 2 and 3, statistically significant difference ($p < 0.05$) were found using Friedman's test. To know which of these programs differed significantly at different frequencies, Wilcoxon's test was

administered. This revealed that a significant difference existed at 1 kHz between P2 and P3, and at 6 kHz between P1 and P2 (Table 4.2). Though aided thresholds at other frequencies differed in P1, P2, and P3 slightly as can be observed in Figure 4.1, there was no significant difference. These findings can be attributed to the fact that NAL-NL1 is an average based formula and does not consider the individual differences that govern the individual's listening needs of the hearing aid user. Hence, even after applying first fit using NAL-NL1, optimum performance can be expected after fine tuning to suit individual requirements.

Table 4.2: Programs which differ significantly from each other at various frequencies for the group with moderate hearing loss

<i>Frequency (Hz)</i>	<i>$\chi^2 (2)$ (obtained from Friedman's test)</i>	<i>Pairs which are significant from Wilcoxon's test</i>
250	2.38	-
500	5.14	-
750	0.40	-
1000	6.50 **	P2 & P3
1500	1.60	-
2000	3.50	-
3000	4.31	-
4000	3.11	-
6000	7.63 **	P1 & P2

** $p < 0.05$

4.1.2 Group with Moderately Severe Hearing Loss

The aided thresholds for this group were higher than that for the moderate group which can be attributed to the greater degree of hearing loss. However, the participants of this group showed a pattern similar to that of the moderate group in terms of aided thresholds. That is, the aided threshold at high frequencies was higher than at low frequencies (Figure 4.2).

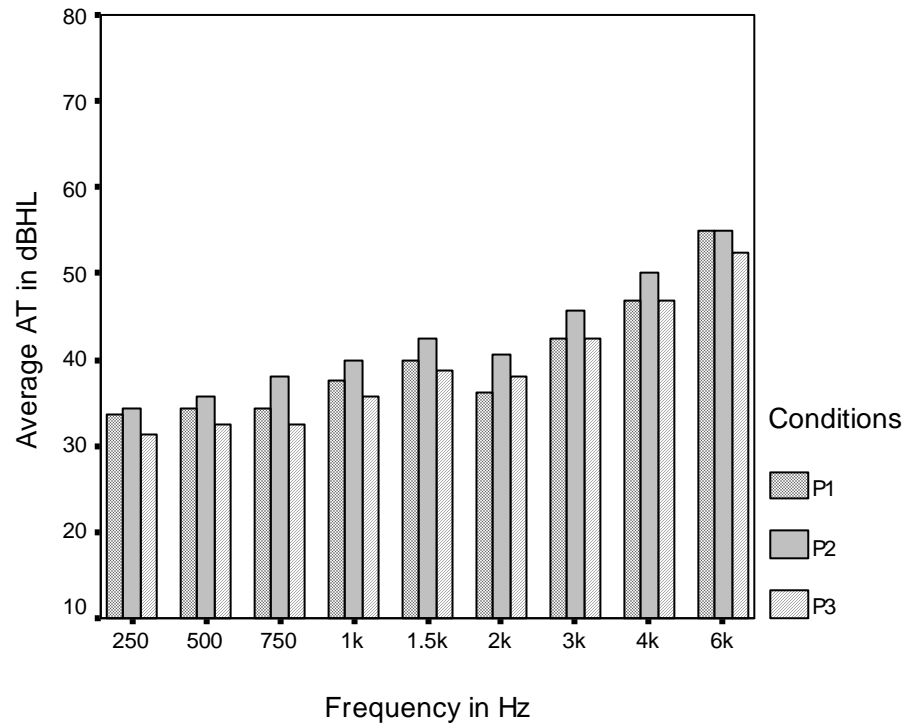

Fig. 4.2: Average aided thresholds for the group with moderately severe hearing loss for P1, P2, and P3 at each tested frequency

On comparing the aided thresholds for P1, P2, and P3 across frequencies for the moderately severe group, the aided thresholds were better with fine tune settings (P3) than with NAL-NL1 settings (P2). However, when Friedman’s test was used to examine if these differences were significant (Table 4.3), 750 Hz, and 1 kHz showed statistically significant difference between aided thresholds between P2 and P3 ($p < 0.05$), showing that fine tune settings resulted in significantly better thresholds at these two frequencies than NAL-NL1 settings, as these settings were programmed according to the requirements of the participants. This finding implies that fine tune settings give better aided thresholds than NAL-NL1 program.

Table 4.3: Programs which differed significantly from each other at various frequencies for the group with moderately severe hearing loss

<i>Frequency (Hz)</i>	<i>χ^2 (2) (obtained from Friedman's test)</i>	<i>Pairs which are significant from Wilcoxon's test</i>
250	2.48	-
500	4.80	-
750	6.08 **	P2 & P3
1000	6.33 **	P2 & P3
1500	2.47	-
2000	2.95	-
3000	2.57	-
4000	3.26	-
6000	5.33	-

** p < 0.05

4.1.3 Group with Severe Hearing Loss

Aided thresholds for the group with severe hearing loss also showed a pattern similar to the groups with moderate and moderately severe hearing loss, with aided threshold for the NAL-NL1 program being higher than the fine tune setting (Figure 4.3 & Table 4.1).

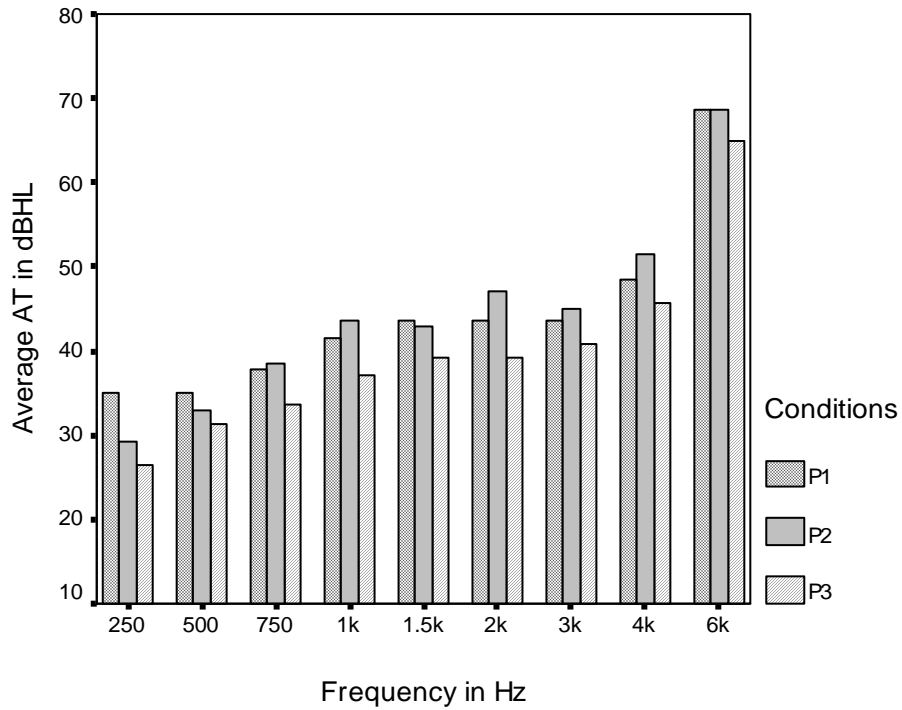

Fig. 4.3: Average aided thresholds for group with severe hearing loss for P1, P2, and P3 at different frequencies

The aided thresholds were higher at high frequencies than at low frequencies.

Further, the aided thresholds with P3 were lower than that prescribed by NAL-NL1 at all the frequencies. To examine if these differences between the programs were significant, Friedman's test was administered. It was noted that significant difference existed at 250 Hz (between P1 & P3), and at 1 kHz (between P1 & P3, and P2 and P3, Table 4.4).

Table 4.4: Programs which differed significantly from each other at various frequencies for the group with severe hearing loss

<i>Frequency</i>	<i>χ^2 (2) (obtained from Friedman's test)</i>	<i>Pairs which are significant from Wilcoxon's test</i>
250	6.58 **	P1 & P3
500	3.26	-
750	4.46	-
1000	8.27 **	P1 & P3, P2 & P3
1500	5.70 *	P1 & P3
2000	5.82 *	P2 & P3
3000	0.92	-
4000	1.04	-
6000	1.20	-

** p< 0.05; * p< 0.1

Difference between P1 and P3 at 250 Hz and 1 kHz shows the degree of change in the preference of hearing aid setting by a hearing aid user over a period of time.

Statistically significant differences (p<0.1) were also seen at 1.5 kHz and 2 kHz between P1 and P3, and P2 and P3 respectively. Statistically significant difference between aided thresholds for P2 and P3 at 1 kHz again proves that fine tune settings provide better aided thresholds than NAL-NL1 setting.

In all the three groups, i.e., moderate, moderately severe, and severe, P1 also showed equal or better thresholds than P2, though not statistically significant, for most of the frequencies (more so in the moderate and moderately severe groups), as can be noted from Figures 4.1, 4.2 and 4.3. This goes on to prove that participants in the study, even

with no previous experience, preferred a hearing aid setting that provided them with improved thresholds when compared to the NAL-NL1 setting, except at 250 Hz and 500 Hz.

4.2 Speech Recognition Scores

Speech Recognition Scores (SRS) were also compared for P1, P2 and P3 across the three groups. Mean and Standard Deviation for SRS are given below in Table 4.5. From the table it can be observed that the SRSs were highest with P3 settings, in all the three groups.

Table 4.5: Mean and Standard Deviation (SD) of aided SRS across three hearing aid programs (P1, P2, & P3) for Moderate, Moderately Severe and Severe hearing loss groups

<i>Prog</i>	<i>SRS in Groups based on severity of Hearing Loss</i>					
	<i>Moderate</i>		<i>Moderately Severe</i>		<i>Severe</i>	
	<i>Mean</i>	<i>S.D.</i>	<i>Mean</i>	<i>S.D.</i>	<i>Mean</i>	<i>S.D.</i>
P1	22.40	1.14	22.00	1.77	22.57	1.51
P2	22.80	0.84	21.50	2.14	22.86	1.35
P3	23.80	0.45	22.75	0.89	24.00	1.00

Statistical tests, as mentioned earlier, were run to check for the presence of any significant difference in SRS for the three program settings P1, P2, and P3 (Table 4.6).

Table 4.6: Programs which differed significantly from each other in SRS for moderate, moderately severe and severe hearing loss groups.

	$\chi^2 (2)$ (obtained from Friedman's test)	Pairs which are significant from Wilcoxon's test
Moderate	5.20	-
Moderately Severe	5.16	-
Severe	5.55*	P2 & P3

* $p < 0.1$ level

Results revealed no significant difference in SRS, even at 0.05 level of significance, across the three programs, except for SRS in those with severe hearing loss. In this group, the SRS was significantly higher with P3 than with NAL-NL1. This implied comparable speech recognition provided by the three program settings used in the experiment with all the three programs.

However, this can also be attributed to 'ceiling effect', i.e., the hearing aids had reached their optimum performance with the first program itself and hence no statistically significant improvement was noted in SRS, though there were changes in aided threshold across programs.

For the group with severe hearing loss, significant difference (at $p < 0.1$ level) was seen in SRS between programs P2 and P3, indicating a significant improvement in SRS from P2 to P3.

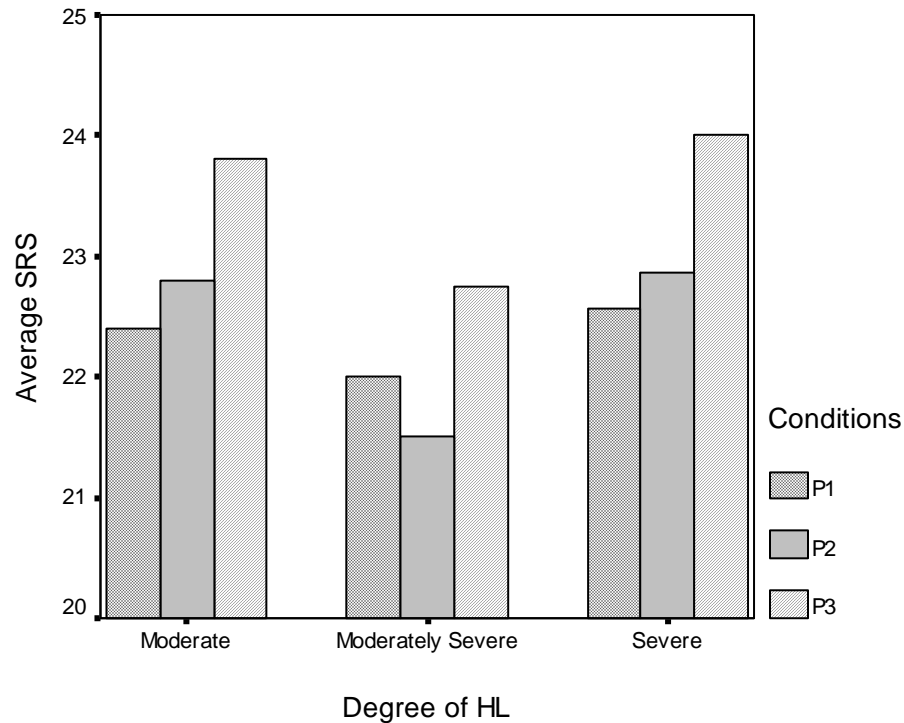

Fig. 4.4: Average aided SRS for P1, P2, and P3 across the three groups of participants.

As can be noted from Figure 4.4 and Table 4.6, though there was no significant difference between the three programs, there was an improvement in SRS from P2 to P3 for all the three group of participants, proving the enhancement in speech identification with fine tune programming (P3) over NAL-NL1 programming (P2). However, such a conclusive trend is not evident for P1 and P2.

4.3 Uncomfortable Level

Uncomfortable level (UCL), like SRS, was compared for P1, P2 and P3 across the three groups. From Table 4.7 and Figure 4.5 it can be noted that the level at which the loudness was uncomfortable were higher in P3 than in P2 in all the groups of participants. These differences were not statistically significant as revealed by Friedman's test,

implying that comparable uncomfortable levels were provided by the three program settings, i.e., P1, P2 and P3. However, ceiling effect could have been a reason for this, as in SRS.

Table 4.7: Mean and Standard Deviation (SD) of aided UCL across three hearing aid programs (P1, P2, & P3) for Moderate, Moderately Severe and Severe hearing loss groups

<i>Prog</i>	<i>Severity of Hearing Loss</i>					
	<i>Moderate</i>		<i>Moderately Severe</i>		<i>Severe</i>	
	<i>Mean</i>	<i>S.D.</i>	<i>Mean</i>	<i>S.D.</i>	<i>Mean</i>	<i>S.D.</i>
P1	89.00	2.24	85.63	4.96	85.71	5.35
P2	86.00	5.48	86.25	5.83	84.29	5.35
P3	88.00	4.47	86.88	4.58	85.71	5.35

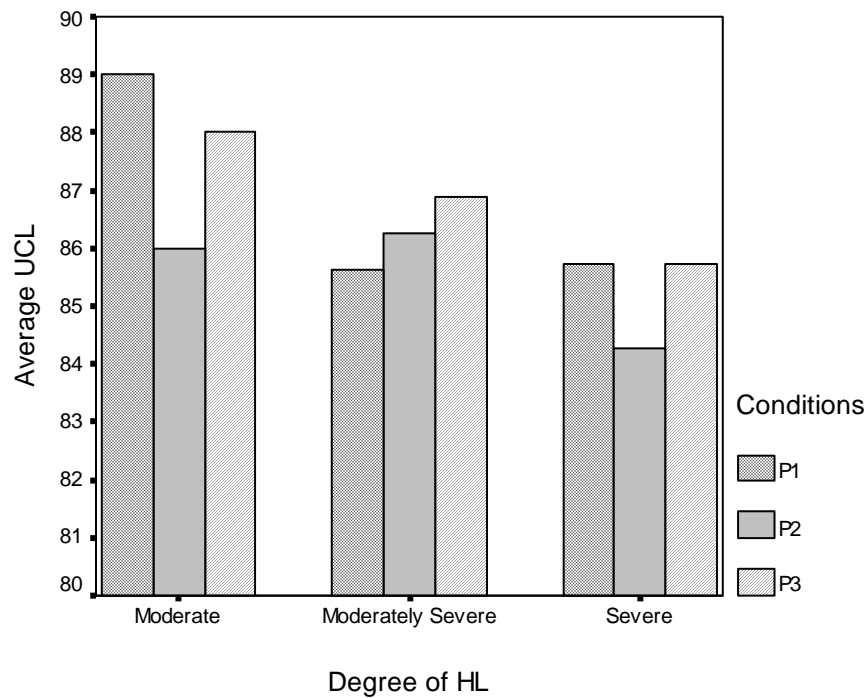

Fig. 4.5: Average aided UCL for P1, P2, and P3 across the three groups of participants.

Also, unlike SRS, no trend in improvement of UCL was seen from P2 to P3 and the results remain inconclusive regarding the trend of UCL with the three programs, P1, P2, and P3 because the speech noise remained tolerable at the maximum limits of audiometer in all the three programs for all the participants. Subjective ratings on intelligibility and quality could have given additional information on the subjective benefit achieved by various programs used in the study.

Objective Tests

Objective tests, i.e., REIG and RESR, were carried out for 10 of the 20 participants. Mean and SD of the REIG revealed variations across the three programs and across the tested frequencies as shown in Table 4.8. The results have been discussed separately for the moderate, moderately severe and severe groups.

Table 4.8: Mean and Standard Deviation (SD) of REIG with three hearing aid programs (P1, P2, & P3) for three groups of participants

Freq.	Prog.	<i>Groups based on severity of hearing loss</i>					
		<i>Moderate (N= 2)</i>		<i>Moderately Severe (N= 4)</i>		<i>Severe (N= 4)</i>	
		<i>Mean</i>	<i>S.D.</i>	<i>Mean</i>	<i>S.D.</i>	<i>Mean</i>	<i>S.D.</i>
200	P1	27.70	34.37	2.95	10.75	0.03	13.67
	P2	35.65	33.87	2.65	12.64	26.10	16.58
	P3	30.70	30.97	7.33	11.35	23.58	8.21
500	P1	32.25	36.70	14.00	12.71	11.40	15.02
	P2	37.75	38.82	9.80	15.37	34.88	17.92
	P3	33.55	37.26	18.50	14.25	36.05	8.75
700	P1	43.05	30.62	22.75	6.91	24.13	6.18
	P2	47.90	28.43	19.30	11.60	39.08	17.64
	P3	45.00	36.35	25.45	11.17	42.70	9.87
1000	P1	45.25	29.06	27.65	6.63	28.63	7.42
	P2	43.95	17.89	24.20	5.27	38.60	15.58
	P3	47.90	31.96	28.65	8.01	43.15	8.37
1500	P1	49.65	29.77	33.35	9.02	33.30	8.77
	P2	43.00	21.35	28.88	5.61	37.68	7.48
	P3	51.25	32.88	34.75	8.83	47.63	3.07
2000	P1	41.65	28.78	39.40	12.73	40.15	11.40
	P2	38.75	8.98	35.20	8.21	42.90	5.88
	P3	45.65	30.90	40.93	12.92	53.18	2.87
3000	P1	43.95	20.15	44.83	11.90	44.85	11.62
	P2	37.85	3.32	37.68	4.66	41.10	7.27
	P3	42.70	24.89	43.13	12.18	50.28	6.79
4000	P1	40.95	13.65	33.40	10.77	31.88	11.93
	P2	36.35	3.18	29.20	8.17	30.63	0.39
	P3	40.05	16.76	32.98	11.08	38.78	7.35
6000	P1	29.00	13.15	18.90	5.80	20.48	4.72
	P2	30.30	1.70	15.08	9.65	23.93	4.47
	P3	32.65	13.36	21.78	5.51	26.23	2.81
8000	P1	23.40	19.23	5.700	11.22	5.50	10.09
	P2	24.10	16.69	10.78	10.02	14.75	5.68
	P3	23.60	21.78	5.53	5.95	9.68	3.62

4.4 REIG

Table 4.8 shows the mean and standard deviation (SD) for the insertion gain for the three groups of participants. As can be noted from the table and Figures 4.6, 4.7 and 4.8, the insertion gain provided by the hearing aid is greater at the mid frequencies than at the lowest or the highest frequencies in all the three program settings, i.e., P1, P2, and P3. This shows the importance that is given to these frequencies for speech perception not just while calculating the generic formula (NAL-NL1, P2), but also by the participants themselves while selecting the tailor made program for their hearing aid (P1 and P3). This also reflects the lesser efficiency of the hearing aid in amplifying the low and high frequencies.

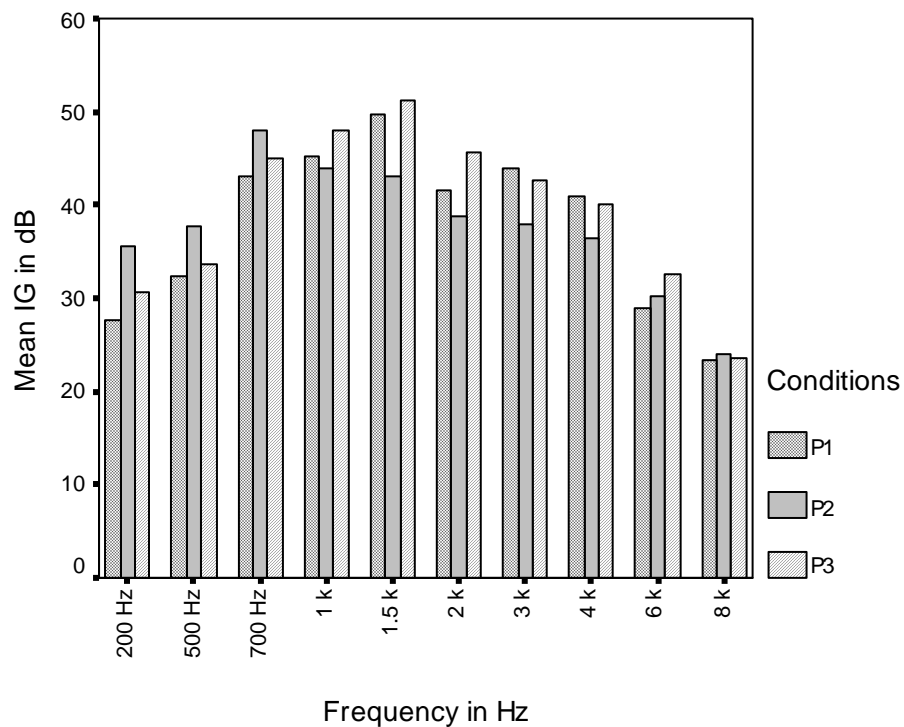

Fig. 4.6: Average REIG for group with moderate hearing loss for P1, P2, and P3 at tested frequencies

4.4.1 Group with Moderate Hearing Loss

Owing to the lesser number of participants in the moderate group (N=2), no statistical tool could be applied to check the influence of the three programs on REIG. However, as can be noted from Figure 4.6, the fine tune program gave higher insertion gain than the NAL-NL1 program through 1 kHz to 6 kHz, i.e. at frequencies, which are important for perception of speech.

At the lower frequencies, i.e., 200 Hz, 500 Hz and 700 Hz, the P2 consistently gave greater insertion gain than P1 and P3 (Figure 4.6). However, this was not reflected as better aided threshold at the lower frequencies for the moderate group.

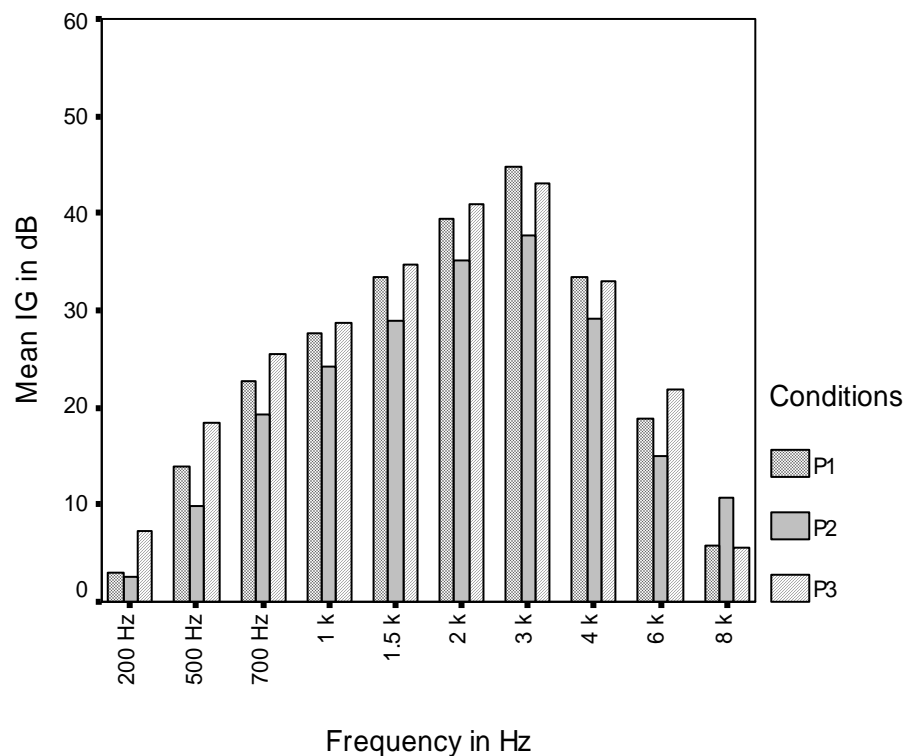

Fig. 4.7: Average REIG for group with moderately severe hearing loss for P1, P2, and P3 at different frequencies

4.4.2 Group with Moderately Severe Hearing Loss

For the group of participants with moderately severe hearing loss (N=4), Friedman's test was administered to evaluate the influence of the three programs (P1, P2, P3) on the insertion gain of hearing aid.

The insertion gain again showed similar pattern, i.e., greater gain for the mid frequencies as compared to the lower and higher frequencies for P1, P2, and P3. However, in this group, no statistically significant difference was noted between P1, P2 and P3 (Figure 4.7). This indicated that for the group with moderately severe hearing loss, the gain provided by the prescriptive formula, NAL- NL1, approximated the actual gain preferred by the participant, even after prolonged use of the hearing aid.

Even though there was no statistically significant difference between the real ear insertion gain (REIG) of P1, P2, and P3, from Figure 4.7, it can be observed that the REIG in P3 was higher than that in P1. Despite there being statistically insignificant difference in REIG, an improvement in the aided threshold, SRS and UCL was noted for the group of participants with moderately severe hearing loss. We can attribute the difference in results to the lesser number of participants in this group.

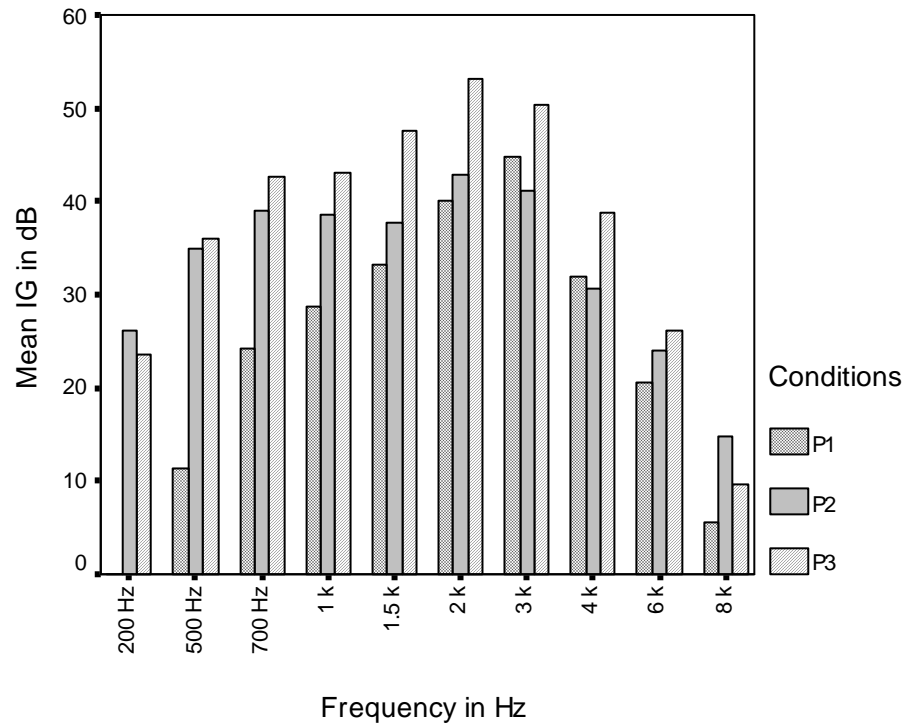

Fig. 4.8: Average REIG for group with severe hearing loss for P1, P2, and P3 at tested frequencies

4.4.3 Group with Severe Hearing Loss

Friedman's test was administered for the group of participants with severe hearing loss to examine if there was any significant difference in REIG at different frequencies. At 200 Hz, the Wilcoxon's test revealed a significant difference between the preferred setting (P1) and NAL-NL1 setting (P1). Also significant difference between preferred setting (P1) and fine tune setting (P3). Similarly, at 8 kHz, significant differences were noted between P1 and P2, and also between P2 and P3.

This difference, as can be noted from Figure 4.8, is in reverse direction, with NAL-NL1 program giving higher gain at both these frequencies than the preferred and fine tune programs. This implies that the NAL-NL1 formula over estimated the gain needed at these frequencies.

For many participants, at 200 Hz the mean REIG for P1 approximated zero as for many participants in this group, the REIG was in negative values, which nullified the mean REIG. This is because the hearing aid does not significantly amplify at very low frequencies.

At other frequencies, though statistically insignificant, greater REIG was seen for P3 than P2 (Figure 4.8 & Table 4.9) which shows that the insertion gain was higher with the fine tune program than that provided by the generic NAL-NL1 formula.

Table 4.9: Programs which differed significantly in REIG at different frequencies for the group with severe hearing loss

<i>Frequency</i>	<i>χ^2 (2) (obtained from Friedman's test)</i>	<i>Pairs which are significant from Wilcoxon's test at 5% level</i>
200	6.50**	P1 & P2, P1 & P3
500	3.50	-
700	3.50	-
1000	1.50	-
1500	6.00	-
2000	6.00	-
3000	1.20	-
4000	6.00	-
6000	3.50	-
8000	6.50**	P1 & P2, P2 & P3

** p < 0.05

4.5 RESR

Mean and Standard Deviation (SD) of RESR for the three participant groups is as shown in Table 4.9. As can be observed from this table and from Figures 4.9, 4.10, and 4.11, no general pattern or behaviour can be attributed to the RESR across the various degrees of hearing loss. Like in the case of REIG, here also greater output across three programs was observed for frequencies of interest, though the difference between low, mid and high frequencies was not as pronounced as seen in REIG. The RESR was higher with P3 compared to P2 (NAL-NL1) except at frequencies below 700 Hz.

Table 4.10: Mean and Standard Deviation of RESR across three hearing aid programs (P1, P2, & P3) for Moderate, Moderately Severe and Severe hearing loss groups

Freq. (Hz)	Prog.	<i>Groups based on severity of Hearing Loss</i>					
		<i>Moderate</i> (N= 2)		<i>Moderately Severe</i> (N= 4)		<i>Severe</i> (N= 4)	
		<i>Mean</i>	<i>S.D.</i>	<i>Mean</i>	<i>S.D.</i>	<i>Mean</i>	<i>S.D.</i>
200	P1	138.10	41.30	104.20	4.79	107.10	3.26
	P2	145.25	39.67	100.43	6.77	116.90	11.77
	P3	136.20	35.21	103.88	7.94	114.83	7.71
500	P1	141.85	48.58	117.60	9.49	121.45	6.38
	P2	145.15	50.70	105.83	12.05	128.55	9.84
	P3	141.30	46.39	114.50	12.30	128.18	9.29
700	P1	154.15	40.09	124.45	7.49	128.93	3.86
	P2	155.50	40.16	112.65	10.26	132.50	9.82
	P3	151.80	44.55	124.28	7.98	136.33	6.21
1000	P1	156.50	38.33	125.93	7.65	125.13	6.99
	P2	152.30	33.52	118.98	4.00	121.20	6.77
	P3	153.00	43.13	125.40	5.62	135.93	7.10
1500	P1	158.95	39.24	128.98	6.42	127.43	8.06
	P2	148.10	33.80	125.40	3.86	126.90	4.10
	P3	157.45	42.92	127.25	9.68	138.25	0.74
2000	P1	149.05	40.09	132.83	11.94	134.40	9.83
	P2	145.50	20.51	131.45	6.07	132.50	3.92
	P3	149.80	41.72	134.63	11.30	144.75	5.06
3000	P1	150.50	30.26	136.45	11.75	137.33	10.42
	P2	142.25	12.80	133.15	4.92	132.18	3.63
	P3	148.40	34.93	136.60	10.90	142.95	7.25
4000	P1	150.55	25.81	119.65	14.15	120.75	12.74
	P2	141.75	7.99	123.85	7.53	116.10	6.38
	P3	144.75	29.20	127.60	10.52	130.15	9.32
6000	P1	134.45	27.79	107.00	14.17	110.15	12.48
	P2	132.40	13.72	110.10	10.21	104.33	11.02
	P3	136.80	27.15	116.23	5.53	108.28	12.08
8000	P1	124.70	27.44	100.83	13.59	102.65	11.71
	P2	119.45	18.03	107.68	10.29	92.73	19.00
	P3	120.55	25.53	102.15	6.45	100.45	6.62

4.5.1 Group with Moderate Hearing Loss

As in the REIG, the number of participants was again too less to conduct any statistical test for the moderate group (N=2). Hence, descriptive statistics was used to study the effect of three programs (P1, P2, and P3) across the frequencies in this group of participants.

The results for RESR for the group with moderate hearing loss were similar to the REIG responses of the same group. The RESR was higher in the mid frequencies than at low and high frequencies, in all the three programs.

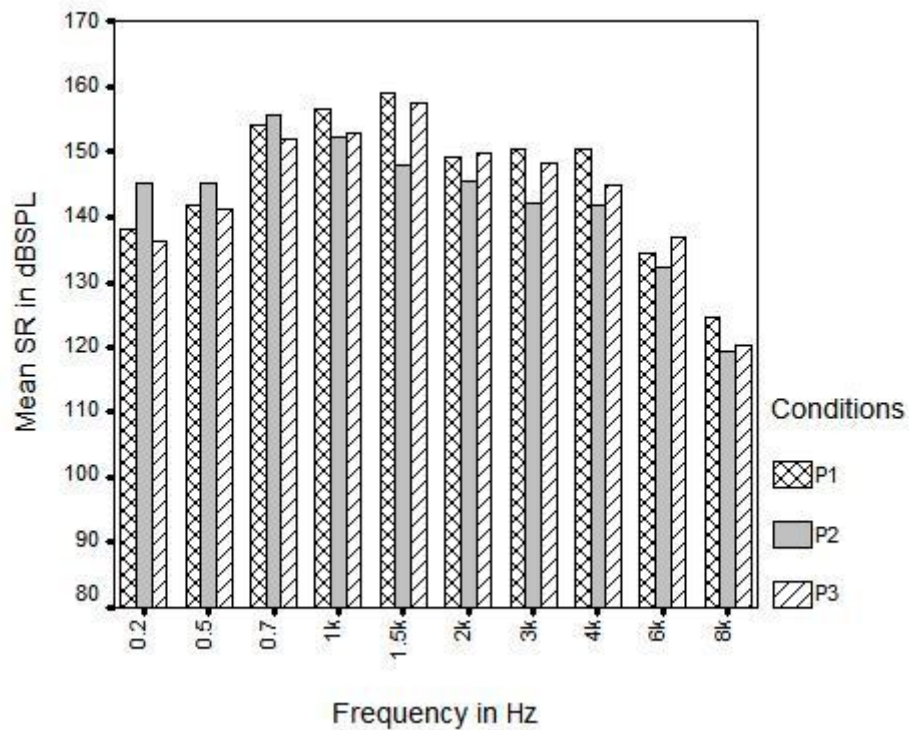

Fig.4.9: Average RESR for group with moderate hearing loss for P1, P2, and P3 at different frequencies

4.5.2 Group with Moderately Severe Hearing Loss

The group with moderately severe hearing loss consistently showed greater RESR values across frequencies (except at 8 kHz) for P3 compared to P1, as can be noted from

Figure 4.10. This indicates that the hearing aids with fine tune programs are better equipped to work at higher input levels without causing discomfort to the wearer or causing feedback. Though visible from the Figure, this difference was not statistically significant (on Friedman’s test) throughout the entire frequency range.

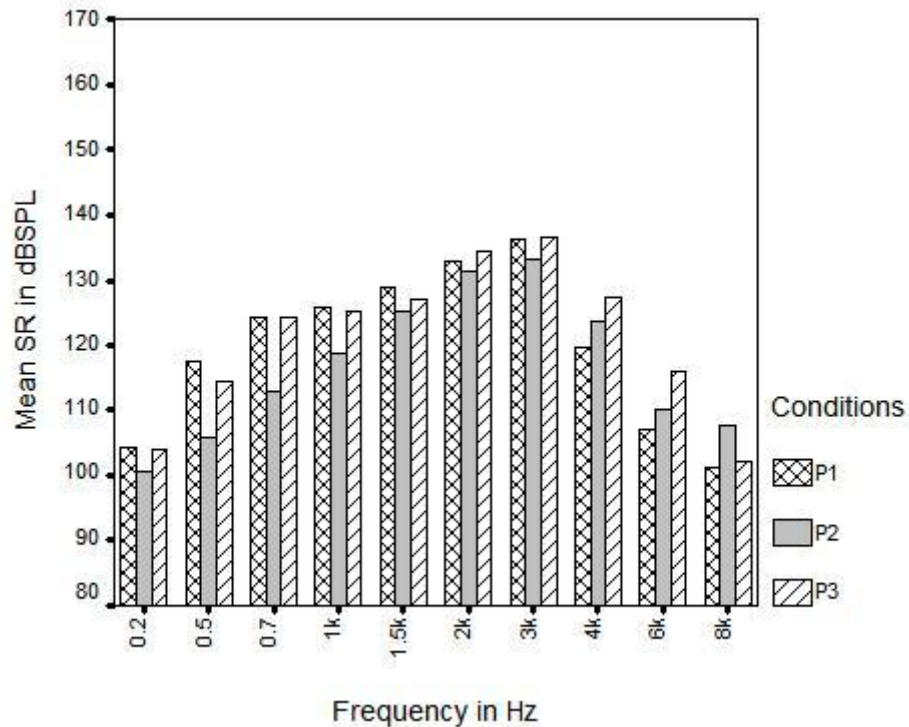

Fig. 4.10: Average RESR for group with moderately severe hearing loss for P1, P2, and P3 at different frequencies

4.5.3 Group with Severe hearing Loss

The group of participants with severe hearing loss showed a clear advantage of P3 over P2, as evident from Figure 4.11. From this figure, it can be observed that the RESR was higher with P3 except at 8 kHz. However, statistically significant difference from Friedman’s test in RESR across programs (Table 4.10) was revealed only at 4 kHz and 6 kHz.

Table 4.11: Programs which differed significantly from each other on RESR at various frequencies for the group with severe hearing loss

<i>Frequency (Hz)</i>	<i>$\chi^2 (2)$ (obtained from Friedman's test)</i>	<i>Pairs which are significant from Wilcoxon's test</i>
200	0.50	-
500	2.00	-
700	1.50	-
1000	3.50	-
1500	6.00	-
2000	6.00	-
3000	6.00	-
4000	6.50**	P1 & P3, P2 & P3
6000	8.00**	P1 & P2, P1 & P3, P2 & P3
8000	1.50	-

** $p < 0.05$

At 4 kHz, the significant differences were seen between P1 and P3 and between P2 and P3 when Wilcoxon's test was applied. This implies that the fine tune setting gave higher values of saturation response as compared to both, preferred gain (P1) and NAL-NL1 (P2) prescribed settings. At 6 kHz, Wilcoxon's test revealed significant differences between all the three programs, i.e., between P1 and P3, P2 and P3, and, P1 and P2, which goes on to prove that all the three settings used in the study had a different impact on the saturation response of the hearing aid, and the fact that the fine tune setting gave the maximum values of RESR proves the efficacy of fine tuning procedure.

Though statistically non-significant, the same pattern was observed at other frequencies as well (Figure 4.11), except at the lowermost three frequencies. Thus, follow-up of hearing aid users for fine tuning proves beneficial.

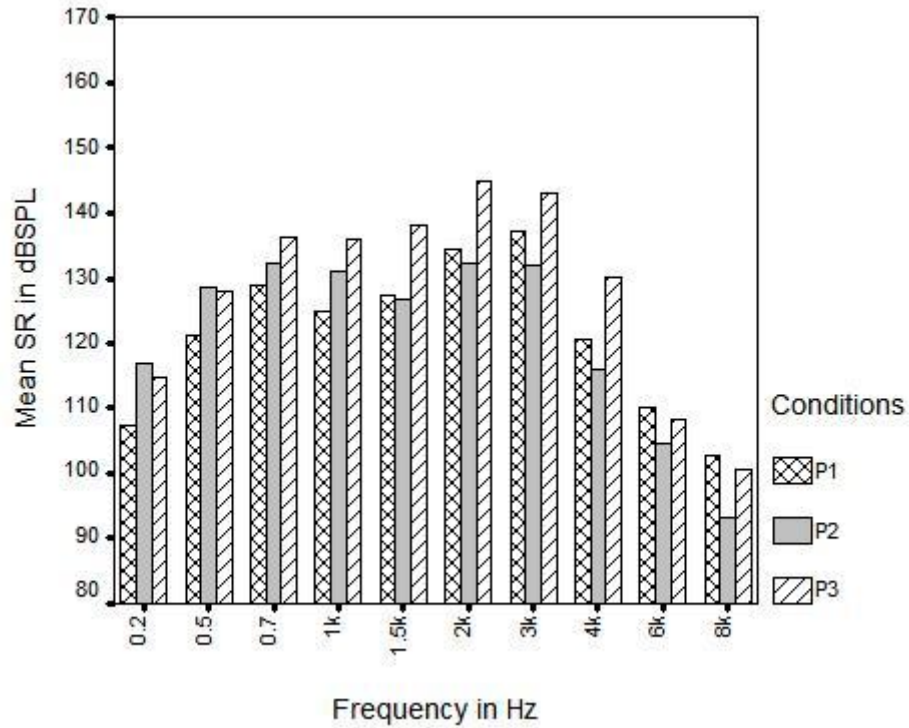

Fig. 4.11: Average RESR for group with severe hearing loss for P1, P2, and P3 at different frequencies

4.6 Comparison of Aided Threshold, REIG, and SRS

As can be noted from the results of REIG, the gain provided by the hearing aid was greater for P3 when compared to P1 and P2 for most of the frequencies and in all the three participant groups. This can be correlated with the results for aided threshold and speech recognition scores, which were better for the P3 program, when compared to P1, thus indicating that fine tune setting gave higher insertion gain, resulting in improved aided thresholds and better speech recognition.

4.6 Comparison of UCL and RESR

RESR values have effect on UCL, i.e., higher the RESR, higher will be the UCL, and better will be the Dynamic Range (DR). On examining the UCL values, one can notice higher, though not statistically significant, UCL for all the three participant groups, which correlates with greater RESR values for the three group of participants for P3 when compared to P2. This proves the advantage that P3 provided over P2.

The overall results of this study stand at odds with the study by Keidser, and Dillon (2006), where they reported NAL-NL1 as being too loud for the first time hearing aid users. As can be noted from REIG and RESR results, the insertion gain as well the saturation response at the time of initial fitting, i.e., with P1 was greater than the gain prescribed by NAL-NL1 (P2), indicating an acceptance of loudness greater than that prescribed by the generic formula in question. Though this difference cannot be proved statistically, which can be attributed to the lesser number of participants in the study, it is still advisable to carry out further research to confirm these results.

However, current study gains support from the work of Arlinger, Lyregaard, Billemark, and Oberg (2000), where they found no correlation between preference and audiological variables.

The results of present study also support that reported by Stelmachowicz, Dalzell, Peterson, Kopun, Lewis, and Hoover (1998), who proved that a proprietary formula, which was a statistical summary of the gains actually used by wearers was more accurate than generic formulae (DSL i/o, and FIG6), which either over- or under- amplified for the degree of hearing loss

The three programming parameters across all the three groups revealed a negligible difference. However, these negligible changes in the programming parameters brought about some significant changes in the perception (as tested subjectively) and real ear measures (as measured objectively). These results are important as they show that even a minimal change in hearing aid programming parameters can improve or adversely affect the performance of the hearing aid and can also affect the benefit that the hearing aid user receives from it. Thus, this may also have an effect on the continued use of the hearing aid. Keidser, and Grant (2001), in their study to compare the performance of NAL-NL1 and IHAF, had reported that even when the difference between the two fittings was small, the subjects preferred and performed better with one program compared to other, proving that even an insignificant change in program is important in terms of subjective results and continued use of hearing aids.

As earlier discussed, most of the results are in favour of the fine tune setting as compared to the preferred settings and the NAL-NL1 setting. It can be safely concluded that the programming done using the 'Fitting Assistant' for fine tuning hearing aids gives better results than the NAL-NL1 program.

Participant's preferred program settings, at the time of first hearing aid trial, usually gave unsatisfactory results with lot of overshooting of the various parameters tested, which can be attributed to the inexperience on the part of the hearing aid user, as they tend to demand greater amplification at the time of first trial of hearing aid. This was observed as all the participants in this study were naïve hearing aid users.

Considering the fact that a heterogeneous group was taken for the study (varying in type and degree of hearing loss), with a limited number of participants, the study could

not reveal significant results or correlations on many parameters. Hence, it is suggested that a study on similar lines be carried out with homogeneous groups to substantiate these results.

Chapter 5

SUMMARY AND CONCLUSION

With the advent of digital hearing aids, a major question that has arisen is regarding the use of appropriate prescriptive formula for programming the hearing aids. NAL-NL1 is one of the most widely used generic prescriptive formulae, devised by the National Acoustic Laboratory, Australia (Dillon, 1999). However, the appropriateness and precision of prescriptive formulae have been questioned time and again, e.g., Keidser and Dillon (2006) reported a change in the gain preferences by adult hearing aid users over time, thus proving that hearing aid programming is more of a subjective issue, and is difficult to tackle with any pre-set, mathematical based calculations.

Hence, the present study was taken up to evaluate the efficacy of NAL-NL1 with which it prescribes the hearing aid parameters for persons with varying types and degrees of hearing loss. It also aimed at finding out the changes observed in the preferred amplification parameters by the hearing aid users after the first 6 to 8 weeks of hearing aid fitment, and how much they deviate from the target curve prescribed by NAL-NL1.

Participant group comprised of 20 naïve hearing aid users, with post-lingual onset of hearing loss. Duration of hearing loss did not exceed five years for any of the participant, and all participants were fluent with Kannada. Degree of hearing loss varied from moderate to severe. NAL-NL1 program setting (P2) was compared with the preferred setting at the time of first hearing aid trial (P1), and fine tune setting (P3), after a minimum of two months of hearing aid use. P3 was adjusted using a fitting assistant questionnaire. The three programs were compared for three sub-groups of participants,

viz. groups with moderate, moderately-severe and severe degrees of hearing loss. As there was no significant difference found between the performances of groups based on type of hearing loss, hence, data from sensori-neural and mixed hearing loss groups were considered as a homogeneous group.

Both subjective and objective tests were conducted to increase the reliability of the findings. Subjective tests included aided thresholds, aided SRS, and aided UCL; whereas, objective tests encompassed REIG and RESR.

Subjective tests revealed a difference in performance with the three programs settings, with greater benefit being shown by the fine tune program (P3) when compared with the preferred (P1) and NAL-NL1 program (P2) settings.

- Significant improvement was noted in aided thresholds in the three participant groups with fine tune program (P3) as opposed to preferred program (P1) and first fit (P2).
- SRSs were also better with P3, for the three groups of participants, compared to P1 and P2 proving the enhancement in speech recognition with fine tune programming (P3) over NAL-NL1 programming (P2).
- Higher UCLs were seen in the three participants groups using P3, than with P2, showing the higher tolerance limit and dynamic range with the fine tune program. Similarly, objective tests also showed greater benefit from the hearing aids with P3 setting as compared to the other two programs (P1 & P2).
- REIG was higher when the hearing aids were programmed to P3, when compared to P1 and P2, proving that hearing aid provided greater insertion gain with P3.

- RESR was also greater with hearing aids programmed according to fitting assistant (P3), than with other two programs. Higher RESR and better UCL for P3 proved that the fine tune program setting not only helped in improved performance with the hearing aid, but also enhanced the dynamic range of hearing.

These findings prove that fine tune program provides better results when compared to NAL-NL1. Re-programming according to individual's listening needs can enhance the benefit that one obtains from the hearing aid. Hence, follow-up for fine tuning of hearing aid should be considered as an integral part of hearing aid prescription procedure for greater user satisfaction and continued hearing aid use. Also, these results can guide us in determining the possible changes in programming parameters, resulting in more client-oriented hearing aid setting on the first trial itself.

However, since only slight changes were present in the programming parameters and only at a few frequencies, the NAL-NL1 can still be considered as the base formula on which changes can be incorporated.

Clinical Implications

The findings of the present study have important clinical implications

- The importance of follow-up and fine tuning can be emphasized for obtaining greater benefit from the hearing aid.
- The information on importance of fine tuning will be useful for hearing aid dispensing audiologists to enhance their knowledge on the probable changes that may occur in the programming over a period of time.

- Comparing and contrasting the changes occurring over time will endure continued use of the device.

Future research

The present study has certain recommendations for future investigations:

- Extensive study with different types of hearing loss, and different degrees of hearing loss can help us identify the pattern of changes required in hearing aid parameters, which can be incorporated at the time of first fit itself, hence eliminating the disuse of hearing aid.
- Also, it is recommended to study such effects with different types of hearing aids, using different technologies.
- Such studies will help us know if technology has an effect on the changes that occur in user preference with hearing aid usage for a period of time.

References

- Arlinger, S., Lyregaard, P.E., Billemark, E., & Oberg, M. (2000). Fitting Hearing Aids to First Time Users. *Scandinavian Audiology*, 29, 150-158.
- Byrne, D. (1986). Effects of bandwidth and stimulus type on most comfortable loudness levels of hearing impaired listeners. *Journal of the Acoustical Society of America*, 80 (2), 484-493.
- Byrne, D. (1987). Hearing aid selection formula: Same or different? *Hearing Instruments*, 38, 5-11.
- Byrne, D., & Dillon, H. (1986). The National Acoustic Laboratories' new procedure for selecting the gain and frequency response of a hearing aid. *Ear and Hearing*, 7, 257-265.
- Byrne, D., & Tonnison, W. (1976). Selecting the gain of hearing aids for persons with sensorineural impairments. *Scandinavian Audiology*, 5, 178-186.
- Convery, E., Keidser, G., & Dillon, H. (2005). A Review and Analysis: Does amplification experience have an effect on preferred gain over time? *The Australian & New Zealand Journal of Audiology*, 27, 18- 32.
- Dillon, H. (1999). What's new from NAL in Hearing Aid Prescriptions? *The Hearing Journal*, 59 (10), 10-14.
- Dillon, H., Byrne, D., Ching, T., Katsch, R., Keidser, G., & Brewer, S. (2000). NAL Research and Development (Annual Report). Karlstad, Sweden.
- Humes, L. E. (1986). An evaluation of several rationales for selecting hearing aid gain. *Journal of Speech and Hearing Disorders*, 51, 272-281.
- Humes, L. E. (1991). Prescribing gain characteristics of linear hearing aids. In G. A. Studebaker, F.H. Bess, & L. B. Beck (Eds.), *The Vanderbilt hearing-aid report II* (pp. 13-22), Parkton, MD: York Press.
- Humes, L. E. (1996). Evolution of prescriptive fitting approaches. *American Journal of Audiology*, 5, 19-23.
- Humes, L. E., & Hacket, T. (1990). Comparison of frequency response and aided speech-recognition performance for hearing aid selected by three different prescriptive methods. *Journal of the American Academy of Audiology*, 1, 101- 108.
- Humes, L. E., & Halling, D.C. (1994). Overview, rationale, and comparison of suprathreshold –based gain prescription methods. In M. Valente (Ed), *Strategies for selecting and verifying hearing aid fittings* (pp. 19-37). New York; Thieme.

- Keidser & Dillon (2006). NAL Research and Development (Annual Report, 2005-06).
- Keidser, G., & Grant, H. (2001). Comparing loudness normalization (IHAF) with speech intelligibility maximization (NAL-NL1) when implemented in a two-channel device. *Ear & Hearing*, 22(6), 501-515.
- Keidser, G., Convery, E., & Dillon, H. (2002). Gain preference relative to the NAL-NL1 prescription. NAL Research and Development (Annual Report, 2002-03), 44-46
- Killion, M.C., & Revit, L.J. CORFIG and GIFROC: Real-ear to coupler and back. In: Studebaker, G.A., & Hochberg, I. (Eds.). *Acoustical Factors Affecting Hearing Aid Performance* (2nd ed.). Boston, MA: Allyn and Bacon; 1993: 65-85.
- Leijon, A., Eriksson-Mangold, M., & Bech-Karlsen, A. (1984). Preferred hearing aid gain and bass-cut in relation to prescriptive fitting. *Scandinavian Audiology*, 13,157-161.
- Leijon, A., Lindkvist, A., Ringdahl, A., & Israelsson, B. (1990). Preferred Hearing aid gain in everyday use after prescriptive fitting. *Ear & Hearing*, 11, 299-305.
- Martin, F.N., Armstrong, T.W., & Israelsson, B. (1994). A survey of audiological practices in the United States. *American Journal of Audiology*, 3, 20-26.
- Martin, F.N., Chaplin, C.A., & Chambers, J.A. (1998). Seventh survey of audiometric practices in the United States. . *Journal of the American Academy of Audiology*, 9, 95-104.
- McCandless, G.A. (1994). Overview and rationale of threshold-based hearing aid selection procedures. In M. Valente (Ed.) *Strategies for selecting and verifying hearing aid fittings* (pp. 1-18). New York; Thieme.
- Moore, B. C. J., & Glasberg, B. R. (1997). A model of loudness perception applied to cochlear hearing loss. *Auditory Neuroscience*, 3, 289-311.
- Mueller, H. G., & Powers, T.A., (2001). Consideration of Auditory Acclimitization in the Perspective Fitting of Hearing Aids. *Seminars in Hearing*, 22 (2), 103- 122.
- Mueller, H.G., (2004). Fitting Hearing Aids to Adults Using Prescriptive Methods: An Evidence-Based Review of Effectiveness. *Journal of the American Academy of Audiology*, 16, 448-460.
- Palmer, C. V., (2001). The Impact of Hearing Loss and Hearing Aid Experience on Sound Quality Judgments. *Seminars in Hearing*, 22, 125-132.
- Smedz, K., (2004). Is normal or less than normal overall loudness preferred by first-time hearing aid users? *Ear & Hearing*, 25 (2), 159-172.

Stelmachowicz, P., Dalzell, S., Peterson, S., Kopun, J., Lewis, D., & Hoover, B (1998). A comparison of threshold based fitting strategies for non-linear hearing aids. *Ear & Hearing*, 19, *Seminars in Hearing*, 131-138.

Yathiraj, A., & Vijaylakshmi, C. S. (2005). *Phonemically Balanced Word List in Kannada*. Developed in Department of Audiology, AIISH, Mysore.

APPENDIX A

FITTING ASSISTANT QUESTIONNAIRE

- I. Sound quality
- ➔ Sounds are
 - hollow, booming, echo effect, bass
 - muffled
 - harsh, sharp, metallic
 - tinny, not full
 - not clear, not distinct
 - poor for music
- II. Intelligibility
- ➔ Poor intelligibility in quiet
 - one-to-one conversation
 - watching TV, listening to radio
 - in reverberant environments
 - using a telephone
 - ➔ Poor speech intelligibility in noise
 - in a restaurant
 - in large groups
 - in a car, in a bus, on a plane
 - on the street
- III. Loudness of sounds
- ➔ Overall loudness is
 - too soft
 - too loud
 - ➔ Low levels (eg. Fan, leaves rustling)
 - too soft
 - too loud
 - ➔ High levels (eg. Party)
 - too soft
 - too loud
 - ➔ Low level, high pitch (birds chirping)
 - too soft
 - too loud
 - ➔ Low level, low pitch (eg. refrigerator)
 - too soft
 - too loud
 - ➔ High level, high pitch (eg. Dishes falling)
 - too soft
 - too loud

- ➔ High level, low pitch sounds (eg. Car door slamming)
 - too soft
 - too loud

- IV. Loudness of speech
 - ➔ Overall loudness
 - too soft
 - too loud
 - ➔ Low levels
 - too soft
 - too loud
 - ➔ Average levels
 - too soft
 - too loud
 - ➔ High levels
 - too soft
 - too loud
 - ➔ Distant speech
 - too soft
 - too loud
 - ➔ Own voice
 - too soft
 - too loud

- V. Feedback/Squeal
 - ➔ Always

APPENDIX B

Phonemically Balanced Word List Developed by Yathiraj and Vijayalakshmi (2005).

raita	tʃukki	hulu	va:t u
anna	hagga	su:dzi	hotte
mola	batta	rotti	doni
tʃa:ku	mantʃa	gu:be	vadzra
tuti	bekku	akka	va:ni
me:ke	lo:ta	e:lu	tale
ha:vu	ba:la	vi:ne	katte
kattu	dze:bu	dimbu	me:dzu
bi:ga	mandi	vade	na:ji
o:du	nona	go:li	ba:lu
bale	male	ha:lu	ni:li
mu:ru	ti:vi	amma	gombe
ra:ni	di:pa:	dzana	ka:ge
tapa:	rave	ravi	adu
ta:ra:	mole	tande	dra:kʃi
braʃu	railu	rakta	bægu
hasu	ka:ru	suttu	kaʃta
dzade	divja	ja:va	paisa
nalli	a:ru	tʃandra	mara
kivi	pu:ri	ja:ke	hu:vu
varʃa	haddu	a:le	tinnu
ja:ru	suʃma	aidu	idli
da:na	ta:ji	nadi	ke:lu
ʃæmpu	dana	uppu	sara
ili	a:lu	kriʃna	pada