

GENETICS IN STUTTERING

ANJANA.B.R.

Register No.: 02SH0003

A Dissertation submitted in part fulfillment of
Final year M.Sc. (Speech and Hearing),
University of Mysore, Mysore

**ALL INDIA INSTITUTE OF SPEECH AND HEARING
NAIMISHAM CAMPUS, MANASAGANGOTRI
MYSORE-570 006**

MAY - 2004

Certificate

This is to certify that this dissertation entitled "**Genetics in Stuttering**" is bonafide work in part fulfillment for the degree of **Master of Science (Speech and Hearing)** of the student (**Register No. 02SH0003**).



Director

Prof. M. Jayaram

All India Institute of Speech Hearing

Mysore-570 006

Mysore
May, 2004

Certificate

This is to certify that this dissertation entitled "**Genetics in Stuttering**" has been prepared under my supervision and guidance. It is also certified that this dissertation has not been submitted earlier in any other university for the award of any diploma or degree.



Guide

Dr. S.R. SAVITHRI

Reader and Head

Department of Speech-Language Sciences,
All India Institute of Speech Hearing,
Mysore-570 006

Mysore
May, 2004

DECLARATION

This is to certify that this dissertation entitled "**Genetics in Stuttering**" is the result of my own study under the guidance of Dr. S.R. Savithri, Reader and Head, Department of Speech-language Sciences, All India Institute of Speech and Hearing, Mysore, and has not been submitted earlier in any other university for the award of any diploma or degree.

Mysore
May, 2004

Register No. 02SH0003

ACKNOWLEDGEMENTS

I would like to express my sincere thanks to Savithri Ma'am for her constant support and guidance throughout this project.

I am grateful to Dr. M. Jayaram, Director, All India Institute of Speech and Hearing, Mysore, for permitting me to carry out this study.

I also thank Sri Kumari Ma'am for her valuable suggestions and guidance.

Amma, Appa, Anna, Lakki and Pradeep Paapa — you've always been a source of support and inspiration for me in all my endeavours. Thanks for being what you are.

Bhushan, you've made me rediscover myself in a whole new perspective, you've given me a new meaning to my life. I am really thankful to god, for giving me you. you've been there for me always and worked with me throughout my project. Thanks for all the help and support.

Thank you aunty, uncle and Ramya for your support.

Puru, it's been five long years and our friendship has bloomed through these five years. I am really thankful to have a friend like you. I will always cherish the times spent with you. Thanks for being there for me.

Sona, thanks for all your support. I will cherish the happy times spent with you.

Adz and Sharad, Gupta and Meenakshi we've been great pals and spent lots of good times together. Thanks for being such wonderful friends.

*I thank all my **classmates** who have directly or indirectly helped me with my project.*

I express my gratitude to all my subjects for their sincere co-operation.

I thank the Library staff, for helping me gain access to the resource materials for my project.

*I thank Staff of **Softouch**, Kuvempunaqar, Mysore for helping me give a final shape to my project.*

*Last but not the least I thank **Lord Almighty** for keeping me enduring and persistent throughout my project.*

TABLE OF CONTENTS

Chapters		Page No.
1	INTRODUCTION	1-8
2	REVIEW OF LITERATURE	9-35
3	METHOD	36-40
4	RESULTS AND DISCUSSION	41-60
5	SUMMARY AND CONCLUSION	61 -63
	REFERENCES	i-iv

LIST OF TABLES

Table No	Title	Page No.
1	Subjects for family study	37
2	Subjects for Twin study	38
3	Questionnaire	39
4	Symbols used in the construction of pedigree	39
5	Frequency of stuttering among the first-degree relatives	41
6	Frequency of stuttering among the second-degree relatives	41
7	Percent stuttering in male and female relatives	42
8	Details of pedigree analysis	44
9	Stuttering in proband's parents	45
10	Details of subjects in twin study	45
11	Male versus female ratio in stuttering	46
12	Consanguinity in stutterers' family	47
13	Percent of persistence and recovery of stuttering among first and second degree relatives	48
14	Age and nature of onset of stuttering	49
15	Percent stuttering in those with stuttering in father /mother	50
16	Percent stuttering in those without stuttering in father / mother	51
17	Stuttering in proband's parents	56
18	Fit of the single-major-locus model to the family incidence data on stuttering	59

LIST OF FIGURES

Figure	Title	Page No.
1	Graphical representation of multi-factorial model	17
2	Graphical representation of single-locus model	20
3	Distribution of stuttering among first-degree relatives	43
4	Distribution of stuttering among second-degree relatives	43
5	Pedigrees of all the patients	44(e)
6	Fit of the data to the single major locus model	59

Dedicated
to
all my teachers
and my family

CHAPTER I

INTRODUCTION

Stuttering occurs when the forward flow of speech is interrupted by a motorically disrupted sound, syllable or word or by a speaker's reaction thereto (Van Riper, 1982). Stuttering is familial and there is evidence for vertical transmission in families (Kidd, Heimbuch & Records, 1981). However the mechanisms of that transmission are not clearly understood. A variety of hypotheses have been proposed including several genetic models. Although there is evidence that genetic factors are important for the expression of stuttering, no specific type of genetic transmission has been elucidated.

A genetic factor for a disorder is demonstrated by either a specific structural or functional biochemical defect. No such evidence has been obtained for stuttering. In the absence of such data there are at least four other types of studies, which can provide support for the genetic involvement in a disorder of unknown etiology.

- a) Twin studies,
- b) Family studies,
- c) Separation studies, and
- d) Genetic linkage studies.

In the *twin method*, the proportion of twin pairs in which both members are affected (i.e. the pair is concordant) in a sample of monozygotic (MZ) twins is compared with the proportion of concordant twin pairs in a sample of dizygotic (DZ)

twin pairs. This method is used primarily to obtain preliminary evidence that genetic factors are important in the disorder being studied. MZ twins are genetically identical. Thus if differences between MZ twins occur, they can be due to genetic mutations or due to different environmental influences experienced by the two developing individuals. Because genetic mutation of this type is an extremely rare event, the differences are usually assumed to be environmentally reduced. DZ twins are no more closely related genetically than two siblings born at different times. Any differences between DZ twins are attributed to both genetic and environmental factors. If it is assumed that same sex MZ and DZ twin pairs share equivalent environments then any difference in concordance rates between MZ and DZ twin pairs are due to the fact that MZ twins are genetically identical whereas DZ twins are not. Early twin studies and stuttering examined whether the prevalence of the disorder was increased among twins when compared to singletons. The hypothesis was that stuttering in and of itself might be a risk factor for stuttering. The rate of stuttering reported for twins varied considerably with Nelson, Hunter & Walter (1945) reporting a rate of 20% and Graff (1955) reporting a rate of 1.9%. Godai, Tatarelli & Bonnani (1976) conducted a study in an Italian population and reported concordance rates of 83% for MZ twins (N=12 pairs) and 9% for same sex DZ twins (n=11 pairs). In a study reported by Howie (1981) care was taken to control some of the potential sources for bias. They studied thirty same sex twin pairs (21 males and 9 females). Seventeen of the twins were MZ and 13 DZ. Of the MZ twin pairs, 12 were males and 5 females. Among the DZ pairs, 9 were males and 4 females. Concordance rates for stuttering were significantly higher for MZ twins (58%) than compared to DZ twins (13%). Together these studies yield evidence that genetic

factors are important in the etiology of stuttering. If the two studies are combined, concordance rates are 69% for MZ and 12% for DZ twins. Thus because MZ concordance is significantly higher than DZ concordance, these twin studies are consistent with the hypothesis that genetic factors are important in the expression of stuttering. However, these results provide little information regarding the specific genetic mechanisms involved.

Studies on *biological families* can also yield data suggesting genetic involvement for any given illness and can be used to test specific transmission hypothesis. The family study method consists of comparing rates of illness in families ascertained through an affected individual (the proband) with rates in the general population or with rates in families ascertained through unaffected persons (controls). If the risk of a disorder in families ascertained through an affected person is significantly greater than the risk of the disorder in the population or in the control families, the disorder is familial. This suggests the possible role of genetic factors for the illness. However as with twin studies, if a major environmental component is involved in the etiology of the trait in question, results drawn from family studies will be unable to prove the existence of genetic factors. Data from families can, however be used to demonstrate that vertical transmission occurs. Once vertical transmission has been established, the patterns of illness within families can be compared to those expected under a variety of specific genetic hypotheses. It is assumed that if the pattern of illness within families follows closely a pattern predicted by classical Mendelian hypothesis, it is unlikely that environmental factors could be solely responsible for the transmission.

Andrews & Harris (1964) reported an increased rate of stuttering, among relatives of stutterers. In addition they found that relatives of female stutterers were at greater risk than were relatives of male stutterers. Kay (1964) included information about sex of the proband and sex of the relative in the calculation of risks for first-degree relatives. He found that male relatives of a stutterer (fathers, brothers and sons) are at a greater risk than are female relatives of a stutterer (mothers, sisters and daughters). Kidd, Kidd & Records (1978) and Kidd Heimbuch & Records (1981) found similar risks among first-degree relatives of stutterers. In these studies, the overall risk for stuttering among the first-degree relatives was about 15%. However, distinct differences were obtained between the sexes. The overall rate of stuttering among the relatives of females was 18%, compared to among 14% among relatives of males. When the relatives were separated by sex, additional differences were observed. Stuttering occurred in about 20% of male relatives and 5% of female relatives of male stutterers. Among relatives of female stutterers, approximately, 25% of male relatives and 12% female relatives stuttered. Thus the available family data provide evidence that, stuttering is familial and that specific patterns of vertical transmission occur which appear to be related to the sex of the proband and the relative.

Using this information, specific genetic hypotheses have been examined. Meyer (1945) and Andrews & Harris (1964) found several simple models of transmission, including autosomal dominant, autosomal recessive and X-linked inheritance, to be compatible with the familial patterns observed. Kay (1964) proposed that either a single gene with polygenic background or polygenic model

might account for the data. Kidd (1977) showed that patterns of transmission of stuttering in families were compatible with both a multi-factorial polygenic model and a single major locus model with sex specific thresholds. Kidd's analyses incorporated only summary risk estimates for specific type of relatives. With these kinds of analyses, information regarding the specific patterns of transmission, within each family is lost. Cox, Kramer and Kidd (1984) suggested that discrimination among alternative genetic models might be possible with fuller utilization of family data by segregation analysis.

Segregation analysis allows examination of the pattern of transmission in intact families and therefore has more power than previous methods, which relied on summary frequency data. Cox et al. (1984) performed segregation analysis on a subset of families studied by Kidd and co-workers (Kidd, 1977; Kidd et al., 1978; Kidd et al., 1981) and found that transmission of stuttering observed in those families could not be adequately explained by segregation of a Mendelian major locus. However, the familial patterns could be explained by polygenic transmission.

Although the Yale family study of stuttering is by far the largest to date, there are still a number of difficulties with the study. First of all data about first-degree relatives was obtained through one informant. The vast majority of the first-degree relatives were not seen and evaluated personally. In studies of other behavioral disorders, it has been shown that when rates of illness are calculated with data collected from just one informant, they were consistently low than the true rates of illness in the families (Orvaschel, Thompson, Belanger, Pressoff & Kidd, 1982;

Pauls, Kruger, Leckman, Cohen & Kidd, 1984). Moreover this method of data collection, can affect the pattern of illness observed within the families (Pauls et al. 1984). A second shortcoming of these studies is that it is assumed in all of the genetic analyses that the trait being studied is etiologically and genetically homogenous. Given what is known about stuttering, this assumption is most likely to be wrong. If stuttering were heterogeneous, then the assumption of homogeneity would invalidate all of the segregation analyses performed.

There are at least two other methods available, which provide evidence for genetic factors- Separation studies and linkage studies. Neither type of study has been applied specifically to stuttering. *Genetic linkage* is detectable at least in theory, if a known genetic marker locus is sufficiently close to a locus affecting the trait under study so that non-random segregation of alleles at the two loci results in an association of phenotype in the family. The demonstration of genetic linkage requires family studies showing that alleles at two separate loci are physically close on the same chromosome. Family data are used to estimate how frequently, the alleles at the two loci are transmitted to a child in combinations different from those in the parents. The degree of linkage is measured as the recombination fraction (the frequency of such new combination) and can range from zero (complete linkage) to 0.5 (independent assortment). The minimum recombination frequency of zero is found for alleles that were always transmitted in the same combinations from generation to generation. The maximum recombination fraction of 0.5 is found for alleles (at two separate loci) that have the same likelihood of being transmitted in new combinations as in the same combination from generation to generation. The

maximum recombination fraction occurs for alleles at loci far apart on the same chromosome, and, of course, for alleles at loci on different chromosomes. Hence, maximum recombination is just another way of phrasing Mendel's second law of independent assortment. Linkage results in the violation of the law.

Some methodological problems in detecting linkage in human data include small family sizes, the inability to control mating, and the small probability that the two loci are linked. Historically, the method has had limited applicability, chiefly because, of the small number of sufficiently polymorphic genetic markers that were available for humans. This has changed rapidly because of the advance in genetics brought about by recombinant DNA techniques. This class of polymorphisms is referred to as "restriction fragment length polymorphisms" (RFLPS) because they were visualized as inherited variations in length and defined fragments of DNA when it is digested with specific restriction enzymes. Using these polymorphisms as markers, investigators are making completion of a genetic map of the entire human genome (Helms, Green, Weiffenbach, Bowden, Keith, Stephens, Smith, Akots, Bricker, Brown, Gravius, Muller-Kahle, Phipps, Rising, Ridekar, Powers, Falls, Hogan, Cannizzaro & Donis-Keller, 1988). Markers mapped in this way have been extremely useful in mapping other diseased loci (e.g. Huntington's disease by Gusella, Wexler, Conneally, Naylor, Anderson, Tanzi, Walkins, Ottina, Wallace, Sakaguchi, Young, Shoulson, Bonila & Martin, 1983). It should be anticipated that this methodology would also be useful in attempts to learn more about the underlying genetic factors, which may be important for the expression of stuttering.

As is evident from this brief review, little is known about the genetics of stuttering. New family studies are needed which use state of art methods. In addition to carefully assessing the proband, all members of the family need to be evaluated personally. It is critical in a family study to know every person who has stuttered at some period in his or her life. Only with data like these, it will be possible to test with confidence specific genetic hypotheses. In this context, the present study was planned. The aims of the study were multifold and were as follows.

- 1) To determine pattern of genetic transmission in families,
- 2) To determine pattern of genetic transmission in twins,
- 3) To determine male- female ratio in stuttering,
- 4) To investigate the relation between consanguinity and genetic transmission,
- 5) To investigate the relation between age, nature of onset of stuttering and familiarity.
- 6) To determine the relation between the persistence and recovery of stuttering and familial stuttering, and
- 7) To determine the relation between familial stuttering and stuttering severity.

CHAPTER II

REVIEW OF LITERATURE

The review will include some basic terms of genetics, transmission hypothesis, genetic models, and studies in the area of stuttering.

I Basic terms in genetics

Allele: One of two or more variants of a gene with the same locus on a specified chromosome.

Autosome: Any chromosome with the exception of X and Y, the sex chromosomes.

Chromosome: Nucleoprotein bodies that normally are constant in number in humans (i.e., 46) and carry the genes.

Concordance: In reference to twins, the situation in which both the individuals exhibit a particular trait or disease.

Discordance: In reference to twins, the situation in which only one twin exhibits the trait or disease.

Dizygotic: In reference to twins, resulting from fertilization of different ova by different spermatozoa, also termed fraternal twins.

DNA: Deoxyribonucleic acid, the chemical compound of which genes is made. Found in the cell nucleus from which it determines life functions.

Dominance/dominant: Capacity of an allele for phenotypic expression of a trait, when paired with a different allele that is not, or is only partly expressed.

Expressivity: Described in terms of quality or quantity, the degree to which a particular trait is manifested.

Familial: The occurrence of a trait in at least two members of an immediate or extended family.

Gene: Comprised of DNA, the basic unit involved in the transmission of heritable traits, generally occupying a specific loci on a chromosome.

Gene map/ genetic map: Visual representation of the relative distances between and linear order of genes belonging to certain groups (i.e., genetic markers)

Genome: The complete endowment of hereditary factors.

Genotype: An individual's total genetic constitution, resulting from a particular combination of genes.

Heritability: Expressed in terms of percentage, the portion of the phenotypic variance in one generation of a population, which is genetically determined.

Heterozygous: Having two different alleles at a particular locus of a chromosome

Homozygous-: Having identical alleles at a particular locus of a chromosome.

Index case: The individual whose trait or disease identification was instrumental in the investigation and identification of the same in other family members. Also termed "proband" or "propositus".

Karyotype: For each individual, the sum total of chromosomal characteristics, such as number, size, shape, and grouping within the nucleus.

Linkage: The association of genes not having the same loci, yet found on the same chromosome.

Locus/loci: Gene site on a chromosome.

Mendelian patterns of inheritance/ Mendilian law: Laws of heredity, first expressed by Gregor Mendel, which attempt to explain the manner in which genetic information passes between the parent and progeny.

Monozygotic: In reference to twins, resulting from fertilization of a single ovum.

Mutation: An alteration in the expected or established characteristics of an individual, as a result of the changes in the genotype.

Pedigree: Diagram depicting the genealogical history of a family, illustrating the occurrence of a particular trait or disease in the members.

Phenotype: The visible behaviors or traits that characterize an individual resulting from the interaction of genotypic and environmental factors.

Polygenic inheritance: A type of genetic transmission in which numerous genes with varying loci are related to the manifestation of a particular trait.

Polymorphism: The co-existence in a population, of two or more alleles, with a frequency too elevated to be considered a new mutation.

Prevalence: Within a particular population, the current number of cases of a trait or disease.

Recessivity/recessive: The inability of an allele to express a trait phenotypically, when paired with a different allele that is expressed, or dominant.

Recombination : Process whereby new combinations of genetic material occur, resulting in offspring with different genetic combinations than their parents.

Sex chromosome: X and Y-chromosomes, which are related to sex determination at fertilization.

Sex-limited: A genetic characteristic found only in one sex, or having a reduced occurrence in one sex.

Sex-linked: With reference to genes located on the X- chromosome, and to traits (manifested in either sex) related to such genes. Also termed "X-linked"

X chromosome: One of the two sex chromosomes, found in both females and males.

Y chromosome: One of the two sex chromosomes found only in males.

Zygosity: Related to the number of zygotes from which a multiple birth has resulted.

II Genetic Transmission Hypothesis

There are several reasons for thinking that stuttering might have a genetic component. First, completely apart from its familiarity, which is well documented, stuttering is a specific speech dysfluency that is distinct from other types of dysfluency. A second reason for believing stuttering might be genetic is that speech is the newest, most uniquely human form of behavior. Though humans are

genetically difficult to study, the uniquely human nature of speech precludes an animal model specifically of stuttering. Stuttering does not show a simple pattern of inheritance in families. In some families, only a parent stutters. In some families many relatives stutter. In some families, nobody else among a large number of relatives has ever stuttered. Some families appear to show X-linked recessive inheritance of stuttering because a male stutterer will have an unaffected sister who has affected sons. The seemingly X-linked patterns can be attributed to the clearly sex-modified risks of stuttering. Males are more frequently affected than females, both among probands and among relatives.

Vertical transmission

Stuttering has been hypothesized to have vertical transmission i.e., a parent stuttering increase the risk of an offspring stuttering. The presence of vertical transmission is a prerequisite to most genetic hypotheses.

Yale data on 2035 relatives of 397 unrelated adult stutterers found a strong familial concentration (Kidd, et al., 1981). In this study, families were divided into subsets. Families of adult probands were first classified by whether the proband was a male or female. Both the groups of families were then classified according to stuttering in proband's parents.

- 1) N, neither parent ever stuttered.
- 2) F, father ever stuttered.
- 3) M, mother ever stuttered.
- 4) B, both parents ever stuttered.

It was found that frequency of stuttering increased markedly if the father of the proband also stuttered. Data also suggested that the sex difference involves a transmittable component. A lower overall incidence among females in conjunction with a higher incidence of affected relatives of female stuttering probands suggest that more factors promoting stuttering are required for a female to stutter and that families of female probands have more of those factors since they have more affected members.

Full logistic analysis of the data suggested that the nonrandom distribution within families is statistically significant in a pattern that is a clear demonstration that stuttering shows both vertical transmission within families and sex-modified expression (Kidd et al., 1981).

III Genetic models

Multi-factorial polygenic model (MFP)

The assumptions that characterize the classical multi-factorial polygenic model are as follows:

- A) A quantitative trait P , may be partitioned as $P = A + E$ where A denotes the transmitted factors that contribute to the expression of the trait and E denotes all other random environmental influences on the trait, with the covariance (A, E) equal to zero.

- B) The multiple transmitted factors are of small, equal and additive effect relative to the total phenotypic variance, and
- C) The phenotypic distribution is assumed to be normal.

The multi-factorial model for qualitative traits was first described by Crittenden (1961) and Falconer (1965). They postulated an underlying liability scale, which satisfies all of the preceding criteria. Liability is defined as the sum of all events; both genetic and environmental that contribute to the expression of the trait. A threshold on the liability scale, presumably a reflection of some physiological phenomenon, divides the distribution into affected and unaffected individuals. Any individuals with a sufficient number of factors for the trait (whether genetic or environmental) will exceed the threshold and be classified as affected.

Thus with respect to stuttering, genetic susceptibility is believed to be transmitted through the cumulative contribution of multiple unspecified genes and multiple environmental factors. Implicit in this model is the existence of an underlying liability distribution in the population whose shape resembles a bell shaped curve (Figure 1). Most individuals in the population will possess "normal" or "average" fluency control skills with a small percentage of very fluent and a small percentage of very dysfluent speakers. At some point in this hypothetical distribution lies a threshold that, if exceeded, will result in stuttering. These thresholds can be gender specific with one gender (in the case of stuttering, males) requiring fewer disruptive factors for the expression of the disorder. Because both genetic and environmental factors are shared by first-degree relatives, this model

predicts that the mean performance of the relatives of stuttering probands should be poorer on fluency-related tasks than that of control individuals. That is, although they may not all stutter, the family members of proband subjects should be on average less "fluency competent" than are randomly selected control speakers due to a combination of multiple shared genetic liabilities and environmental exposures.

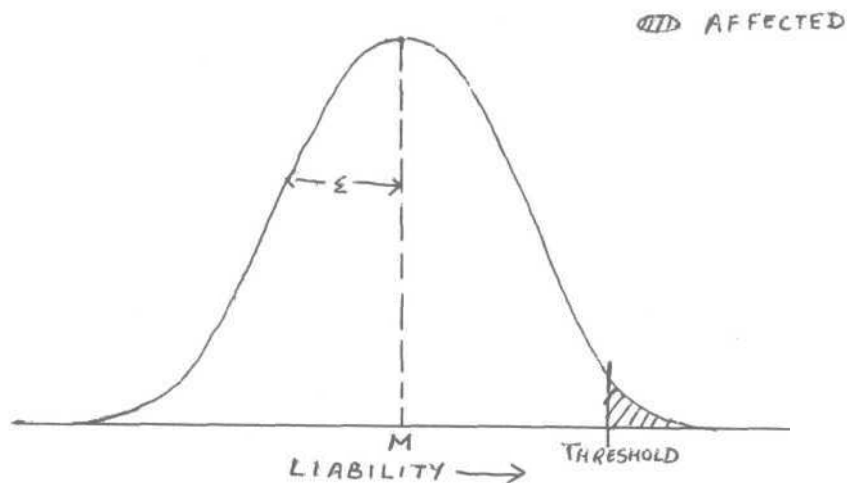

Figure 1: Graphical representation of multi-factorial model.

(This distribution represents the total population and the fraction of affected above the threshold is the prevalence of the disorder. The degree of polygenic determination of the distribution is determined by how much the distribution in relatives of affected probands is shifted up the scale of liability).

Although a multi-factorial-polygenic explanation may seem less satisfying than a single gene hypothesis, this model has been considered by some (e.g., Vanderberg, Singer & Pauls(1986) to be the most likely mode of transmission for stuttering.

Utilizing the properties of the normal distribution, population incidence of the trait, the incidence in various classes of relatives, it is possible to estimate the

heritability for any trait (Falconer, 1965). This model is completely defined by three parameters.

- a) The population prevalence for the more common form of the disorder(or the more common sex)
- b) The population prevalence of the less common form of the disorder(or less common sex), and
- c) The correlation between relatives.

Andrews & Harris (1964) carried out a detailed analysis of stutterers' familial background. They determined the probability of occurrence of stuttering in various categories of relatives in the immediate families of stutterers. They accounted for their results by assuming a sex-limited transmission by means of a large number of non-specific genes. They drew the conclusion that a tendency towards stuttering might be passed down by polygenic inheritance or by a common dominant gene with a multifactorial background.

The single major locus (SML) or two-allele autosomal locus (TAAL) model

The simplest alternative to the multifactorial polygenic model is one in which the genetic or transmitted component is attributable entirely to segregation at a single locus with two alternate alleles. The SML model is quite general and includes classical Mendelian autosomal dominant and autosomal recessive models as sub hypotheses. General predictions for this model include:

- a) Non-Mendelian patterns and frequencies in families and sets of families
- b) Increased risk to subsequent siblings when families are ascertained through more than one affected sibling,
- c) The risk to siblings and offspring of a proband will be greater than the risk to aunts / uncles or nephews / nieces and the risk will continue to decrease, approaching the population incidence asymptotically as the relationship to the proband becomes more remote, and
- d) If a sex or severity difference exists, it may be conceptualized as a different penetrance vector for each type and, when incorporated into the model, usually predicts that less common type of the proband will have a higher frequency of affected relatives than the more common type of the proband.

A variety of methods have been proposed for estimating the parameters of the SML model. Using different analytic techniques, it is possible to obtain parameter estimates from average frequency of affected relatives, from data on segregation in nuclear families, and from more extensive pedigrees. It is worth noting that a single gene model of inheritance does not eliminate the role of environment. Environmental factors are acknowledged to be important in determining the degree to which the phenotype will be expressed (including no overt expression), particularly among heterozygotes. (Kidd, 1980). Thus the predisposing conditions that result from the effects of a major gene are not considered impervious to outside influences and can be overridden by circumstances that are extremely damaging or extremely facilitating (Figure 2).

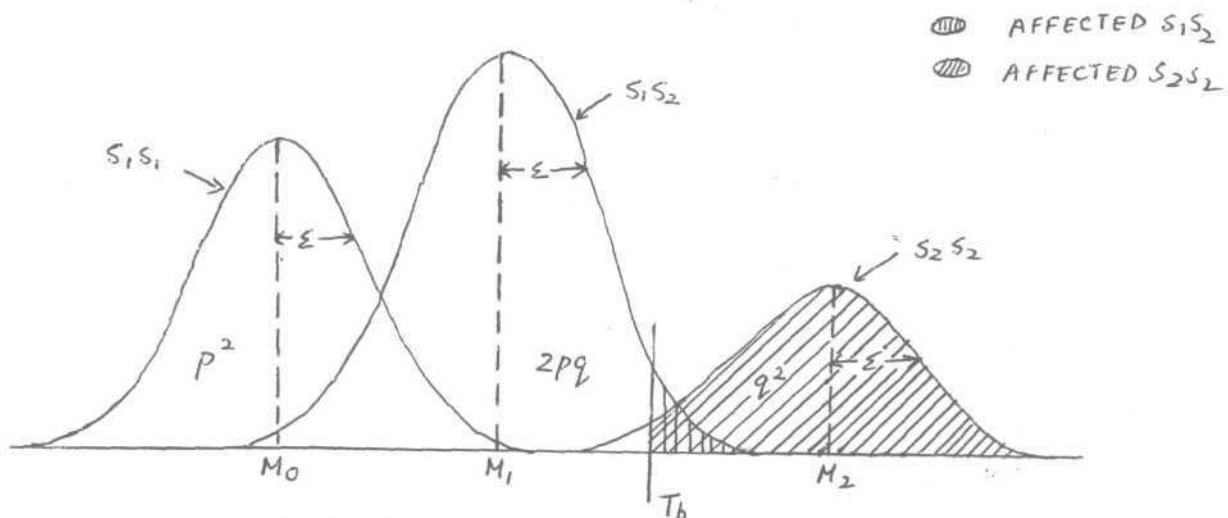

Figure 2: Graphical representation of single-locus model.

The "high susceptibility" form of the gene (allele) is represented by S_2 ; the normal (allele) by S_1 . Individuals will have one of three genetic types - S_1S_1 , S_1S_2 , or S_2S_2 . These genotypes exist in the population in the frequencies p^2 , $2pq$, and q^2 , respectively, where $q=1-p$ is the frequency of the S_2 form of the gene. Each genotype has an average liability (M), but individuals with that genotype are distributed around that value because of nongenetic (environmental) factors. The standard deviation of that distribution is measured by e . Individuals whose susceptibility is above the threshold (T) are affected. In this example some individuals with high genetic susceptibility will be unaffected while some with only moderate genetic susceptibility will be above the threshold and affected. (Modified from Kidd, 1980.)

MacFarlane, Hanson & Walton (1991) reported data from 269 family members of a multi-generation pedigree and found that the stuttering rate was 5 to 15 times higher than that of the general population. Although a formal segregation analysis was not performed, the data was interpreted as theoretically consistent with the transmission at a single major autosomal locus (a major gene on a non-sex chromosome), with different thresholds for males and females

In a recent study, Ambrose, Yairi & Cox (1993) found that the data on the extended families of 69 young stutterers were consistent with a single gene hypothesis. Kidd, Reich & Kessler (1973,1974) from their study concluded that

there is probably a genetic factor in stuttering with a single major locus. They pointed out, however, that the polygenic model also gave an adequate fit to the data. Both the monogenic and polygenic models they tested assume that an individual's total genetic (genetic and environmental) liability to stutter is a variable trait manifested overtly in stuttering when exceeding a certain threshold value which is lower for males than females.

Mixed model

This was proposed by Morton & MacLean (1974). It mixes together the multi-factorial and the single-major locus models. Here the variation around the genotype means is assumed to be in part polygenically inherited with a certain correlation among relatives. Thus if both parents are heterozygotes at the upper end of the distribution for heterozygotes, their children will be distributed among the three major locus genotypes as a result of Mendelian segregation but each will tend to be in the upper portion of his/her respective distribution because of the additive polygenic contribution to the liability. The point to be noted is that we do not yet have enough pedigree information or sufficient statistical power to obtain a reasonable discrimination between competing transmission hypotheses, although it does appear safe to conclude that the null hypothesis of no familial transmission of stuttering can be rejected.

IV Family studies

West, Nelson & Berry (1939) studied family pedigrees of 204 stuttering probands and compared with those of 204 age and gender matched non-stuttering individuals. They found that relatives of stuttering probands were considerably more likely to stutter by a ratio of 6:1. While favoring a biological (genetic) interpretation of their findings, West and his colleagues were careful to note that "strong precipitating factors in the environment could theoretically cause stuttering to appear in cases where hereditary liability was minimal.

Wepman (1939) carried out a similar study where he identified 250 stammerers from clinics and schools in Chicago and Indiana, and paired these cases with a like group of 250 non-stammerers. From these he constructed pedigrees showing the position, age, and sex of each stammerer. The results of the study were similar to West et al's study; once again, the proportion of stutterers found in the families of stuttering cases exceeded those found in the control families by a ratio of 6:1. He also noted that 69% of the proband families had at least one stuttering affected family member in addition to the proband subject. This was compared with the rather low percentage of control families who reported "some incidence of stammering" in the family background (16%).

Gray (1940) carried out a pedigree study of the "X- family" where she focused on a single, large (five- generational) pedigree that tracked two branches of the descendents of a female stutterer. One branch, the Iowa branch was studied in

more detail. This was significantly larger in size than the Kansas branch to which it was compared. She found that the larger Iowa branch contained a higher proportion of current or former stutterers in generation 4 and 5 than was found in the Kansas branch. Gray rejected a sheer hereditarian hypothesis to account for the differences in stuttering frequency found between the two branches. Instead, relying on retrospective and anecdotal reports from the Iowa branch, she concluded that it was likely that the two branches had developed a different "semantic environment" with respect to speech and stuttering.

Johnson, Boehmler, Dalhstrom, Darley, Goodstein, Kools, Neelley, Prather, Sherman, Thurman, Trotter, Williams & Young (1959) obtained information about speech history from 150 families with "allegedly stuttering children" and 150 matched control families with "allegedly non -stuttering children". Results revealed that about 6% of the control parents reported positive family history of stuttering, in comparison with 23% of the parents of allegedly stuttering children.

Andrews & Harris (1964) found a family history of stuttering for 38% of stutterers, but only 1.4% of the controls. Also, among thirty of the stutterers with positive family history, thirteen were reported to have had no direct contact with the stuttering relative, suggesting that imitation or social learning did not play a major role in the etiology of the disorder at least in these cases.

Progress towards sex specific quantification of familial, concentration started in early 1960s. Wingate (1964) reported that 21% of males (n=32) who had

stuttered had relatives in their immediate families who also stuttered and all of who were males. Of the eighteen female stutterers, 33% reported other stutterers in their immediate families, 67% of whom were males. Andrews & Harris (1964) also found that female probands have a higher frequency of affected relatives of both sexes than do the male probands.

Van riper (1971) compiled twenty pertinent studies and found proportion of stutterers with a family history of stuttering ranged from 24 to 80% with a median of 42%.

Kidd, Heimbuch, Records, Oehlert and Webster (1980) analysed the possibility of a genetic component to the severity of stuttering using data on 184 adult stutterers and their families. Frequency of stuttering during pre-treatment oral reading task was used as the severity measure for each of the index cases. Information on whether or not a relative ever stuttered was obtained on all first-degree relatives. The family data variables, including sex and the exact relationship, combined with the birth date and sex of the index case were used in three types of analyses: multiple regressions, AID regressions and stepwise regressions. None of the variables tested was a predictor of the severity of stuttering in the index case. The authors concluded that this measure of severity was not related to the genetic factors, which predispose to stuttering.

Yale family study of stuttering

In the Yale study, information on nearly 600 stutterers and more than 2000 of their first-degree relatives was obtained. Approximately half of the data sample was collected by standardized interview of the proband (or in the case of a child, the proband's parent) and half by a self report questionnaire covering the same material as the direct interview. The diagnosis of stuttering was made by speech-language pathologists for the proband subjects. The relatives were classified as "stuttering affected" through a variety of mechanisms, most typically via the informant (proband) report. The results revealed that approximately 16% of the first-degree relatives of a proband case were also stuttering -affected: 13% of parents, 14% of siblings and 21% of offspring (Kidd, 1983). In addition the author found the risk of stuttering among the first-degree relatives of female probands to be higher than the risk among relatives of male probands. Compared to the population prevalence rates for stuttering, Kidd concluded that stuttering frequencies found among the proband relatives in his studies were significantly elevated, providing additional support for the observation that stuttering aggregates within biological families.

Gladstein, Seider & Kidd (1981) analyzed birth ranks, age separation and frequency of stutterers in birth ranks before and after the proband. Results based on data from over 300 sib-ships showed the following:

- a) Stutterers were randomly distributed among birth ranks.
- b) Age separation of the siblings was independent of stuttering status, and

- c) Frequency of stutterers in birth ranks before the proband and the frequency of stutterers in birth ranks after the proband were not significantly different.

Following this, Cox & Kidd, 1983, used their rich data set to study the phenomenon of stuttering recovery and in doing so, provided future researchers with a model for including epidemiological questions into behavioral genetics design for this disorder. They found that among the first-degree relatives of persistent adult probands, 45 - 51% of those who had ever stuttered had reportedly recovered. Female relatives were significantly more likely to report recovery (66%) than were male relatives (46%), and they were also more likely to report that they began stuttering at an early age and recovered at an early age, on average (12.0 yrs for males and 9.3 yrs for females).

Sieder, Gladstein & Kidd (1983) examined recovery and persistence of stuttering in the first-degree relatives of 388 adult persistent stutterers. Of the relatives, 14% were reported to have ever stuttered. Half of these relatives recovered from stuttering with females recovering significantly more frequently than males. Frequency of recovered stutterers occurring among relatives of persistent stutterers was higher than the frequency of recovered stuttering that has been reported for the general population. This supports the hypothesis that recovered and persistent stuttering are related disorders. Sex and type of relative were significant variables in the distribution of recovery and persistence of stuttering. Handedness (for males) and birth order were not significant variables in the distribution of recovery and

females to cross the disorder and manifest the disorder. The authors gave two important results.

- 1) More females than males in the population stuttered.
- 2) A female stutterer, who carries more deleterious predisposing factors, has more affected relatives.

The Yale study was the first behavioral genetic investigation of stuttering to include an assessment of environmental variables. Cox, Seider and Kidd (1984b) interviewed fourteen stuttering dense and ten control families to determine if any of the 124 prenatal, medical, developmental, social, educational or parental variables they sampled distinguished persons who stuttered from their non stuttering relatives and the control cases. However, in spite of a large number of variables tested, few significant group differences were found. Because the study was flawed methodologically- for example, the investigators relied heavily on retrospective recall, and many of the assessment items lacked sensitivity-the investigators do not provide a definitive test of environmental (etiologic) hypotheses for this disorder. More than any previous genetic study of stuttering, the Yale series illustrated the power and breadth of family study design.

MacFarlane et al., (1991) reported data from 269 family members of a multi-generation pedigree and found that the stuttering rate was five to fifteen times higher than that of the general population. Although a formal segregation analysis was not performed, the data was interpreted as theoretically consistent with the transmission at a single major autosomal locus (a major gene on a non-sex chromosome), with

persistence of stuttering. Onset of stuttering symptoms was significantly earlier in female recovered stutterers

One of the primary objectives of the Yale Family study was to test competing hypotheses about the transmission of stuttering using state-of-the-art segregation analyses programs. Cox, Kramer and Kidd (1984) carried out segregation analyses study in which pedigree data from 386 adult probands and their first degree relatives from the Yale study were entered into two segregation programs. Results from both the programs were consistent and indicated that the best fitting model was one in which stuttering was transmitted as a multi-factorial polygenic condition (i.e., a condition in which multiple genetic loci and /or environmental factors influence the liability to stutter). Cox and colleagues noted that segregation at one or more major loci could not be rejected for a subset of families.

In addition to testing alternative transmission models, Kidd and his colleagues presented an explanation for the observed gender effects for stuttering. Their sex-specific (sex modified/ sex-limited) threshold model, described in varying detail in several papers (Kidd, Kidd & Records, 1978; Kidd 1980, 1983, 1984) essentially proposed that stuttering genotypes are expressed as different susceptibilities based on sex. Because the "stuttering threshold" is hypothesized to be higher for females, it is assumed that more precipitating (genetic or environmental) factors that contribute to stuttering would have to be present for

different thresholds for males and females. MacFarlane et al (1991) ascertained a five generational 1200 member family residing in Utah- Idaho area that had a prevalence of stuttering phenotype at rates several times that of general population. The following were the results of the study.

- 1) Males are more commonly affected than females.
- 2) Transmission from an affected father is more often to an unaffected son than to an affected daughter.
- 3) An affected mother transmits the trait more to sons than daughters.
- 4) Affected females have an affected parent more often than do affected males.
- 5) Affected males may frequently have both parents unaffected.
- 6) Even if both the parents are affected, some offsprings, especially females, may be unaffected.

Ambrose, Cox and Yairi (1997) reported a sample of 66 children aged two to eight years. They divided the proband subjects into those who were persistent stutterers and those who appeared to have recovered from stuttering by 36 months post onset. When the pedigrees of these groups were compared, a significant tendency for recovery status to "breed true" within families was observed.; in other words families tended to express either primarily persistent or primarily recovered stuttering profiles. The authors put forth an interesting biological hypothesis to explain the effect arguing that perhaps "persistent stuttering may be the expression of underlying stuttering, with the same major (genetic) locus component as recovered stuttering, but with other genes promoting a tendency to persist. Results

also indicated sharply different sex ratios of persistent versus recovered stutterers in that recovery among females is more frequent than among males.

Gupta (2001) investigated genetics as a possible cause of stuttering. Five hundred and fifty patients with stuttering were investigated using the family study method. The percentage of their first and second-degree relatives having stuttering was calculated and the pedigrees were constructed for ten stutterers. The results indicated that 32% of the patients with stuttering had relatives who stuttered and that the sex ratio was 6:1 (male vs. female). The results indicated the following:

- 1) Stuttering running in families was found only in 32% of the patients studied.
- 2) There is a possibility that genetics may be a cause of stuttering at least in a subgroup and
- 3) Males are more susceptible to stuttering than females.

It was also found that females had higher percentage of affected relatives than males. The results obtained were congruent to the genetic predictions of the single locus model.

V Stuttering and twinning

The subject of twins has been of importance for stuttering, in relation to the hypothesis about the role of stuttering in its causation. A number of different questions involving twins have been considered in connection with stuttering.

Prevalence in twins

Several studies have been done on prevalence of twins in stuttering population. In fairly large groups of twin pairs, stuttering has been found in 9% of individual members by Berry (1938) and in 13% by Nelson, Hunter & Walter (1945), but only in 1.9% by Graf (1955).

In view of a large number of stutterers found among twins, it is reasonable to expect the converse i.e. a high incidence of twins among stutterers. Berry (1937b) found that 4.5% of 461 subjects were members of a twin pair, as against only 1.2% among 500 non-stutterers.

West & Ansberry (1968) in their study found that a tendency towards twinning and a predisposition to stuttering are genetically linked in some families. An alternative hypothesis offered by West (1958) was that the slowness of early maturation frequently associated with multiple births might contribute to a general constitutional retardation, which he believed to underlie stuttering.

Incidence in twinning families

Berry (1937b) found that twins were more common in the immediate families of stutterers, than in the families of non-stutterers. Berry (1938a) reported that in the immediate families of a group of 250 pairs of twins, 5.5% of the children (i.e. the twins and their siblings) were stutterers. This was due to the abundance of

stutterers among the twins themselves. When the singleton siblings of the twins were considered alone, however, as many as 2.9% of them proved to be stutterers. Andrews & Harris (1964) reported that of a group of 80 stutterers, 19 had a family history of twinning as opposed to 11 in a like number of controls.

Concordance in identical twins

Very little information is available about the concordance of stuttering in twin pairs whose zygosity has been rigorously established. Nelson, Hunter and Walter (1945) conducted a twin study of stuttering. In this study 200 complete twin pairs (69 MZ and 131 DZ pairs) between the ages of four and forty were evaluated. Each twin was examined in the home to obtain evidence of their "similarities and speech habits". They found that the prevalence of stuttering in the twin sample was quite high: 20% of the 200 twin pairs were found to contain at least one stuttering member. Concordance for stuttering was found to differ considerably as a function of zygosity. Of the ten MZ pairs containing at least one stutterer, nine were found to be concordant for the disorder (90%). In contrast, of the thirty dizygotic pairs containing a stuttering member, only two were judged to be concordant for stuttering (7%). However, appropriate methodological safeguards were not employed in the study and hence the concordance rates should be viewed with caution.

Howie (1981a) evaluated thirty same sex twin pairs in which at least one member was reported to be current or recovered stutterer. She found that age — corrected pair-wise concordance rates differed significantly between the types with

10/16 (63%) of the monozygotic pairs and 3/13(19%) of the dizygotic pairs were concordant for stuttering. Although these differences suggest an important role for genetics, Howie herself noted that a large sub group of her identical twins (about 40%) were stuttering discordant. She reasoned that the existence of these discordant MZ pairs highlighted the "importance of the interaction of genetic and environmental factors in the etiology of the disorder.

Godai et al. (1976) in his study on Italian population, found pair wise concordances for stuttering to be 83% for monozygotic twins (twelve pairs) and 10.5% for dizygotic twins (nineteen pairs).

Andrews, Morris-Yates, Howie & Martin (1991) examined the questionnaire responses of 381 adult twin pairs to identify individuals who had responded affirmatively to an item about stuttering. From this large sample, 135 complete pairs were identified that contained at least one self-reported stutterer member (fifty MZ and eighty five DZ pairs). Of the fifty MZ pairs, ten (20%) were concordant for stuttering, in comparison to only 3% of the DZ pairs. When genetic models were fitted to these data, the best- fitting model was one in which 71% of the variance in liability was attributed to genetic variance, with the remaining 29% attributed to the individual's unique environment.

Felsenfeld, Kirk, Zhu, Statham, Neale & Martin (2000) conducted twin study with proband subjects drawn from a sample of 4269 pairs of twins aged 21-28 years. These twins were mailed health questionnaires in 1990-1992, and responses

were received from 1567 pairs and 634 individual twins (a total of 3768 respondents). Two items about stuttering were included on the questionnaire, and these were used to identify positive stuttering cases ("positive screens"). Once identified, these positive screens, their co-twin and a sample of control cases were interviewed by phone to conform the diagnosis, ultimately 91, complete twin pairs (38 MZ and 53 DZ pairs) containing at least one stuttering member were identified in the interview phase of the study. Of these 17/38 MZ and 8/53 DZ pairs were concordant for the presence of the disorder, corresponding to pair wise concordance rates of 45% and 15% for MZ and DZ twins, respectively.

VI Adoption studies

They provide the most powerful of all behavior genetic methodologies for establishing the relative importance of genetic factors in the expression of traits or conditions. Here, information is typically collected from both the biological and adoptive relatives of individuals who were adopted near the time of birth. Any resemblance between the adopted individuals and their biological relatives must reflect their shared genetic background. Only one informal adoption study of stuttering has been reported in speech language literature (Bloodstein, 1993). Bloodstein found that four of the thirteen adoptive families in his study (30%) reported the presence of another stutterer in the family, a rate that argues for a substantial non-genetic effect. However the diagnosis of stuttering in the family members was not verified by direct examination, nor was the author aware of the

family size or the relationship between the proband subjects and their affected relative, which makes the conclusions drawn from the study limited.

Fensfeld (1996) examined data on the occurrence of speech disorders, including stuttering, in four groups of adopted and non-adopted children (biological risk only, adoptive risk only, non adopted at risk and low risk) who were participating in the Colorado Adoption Project (Plomin, Detries, & MacLean, 1980). The children in these groups were considered to be at varying risk for developmental speech disorder based upon their parents' responses to several speech history items on a questionnaire. Results of this study revealed that children with a positive biological history (i.e. genetic) of speech disorder were between 1.2 and 7.5 times more likely to be speech affected than were children who were merely raised by a parent with a positive history (and low risk controls). Of particular interest was the finding that the rate of the disorder among adopted away children of an affected parent was highly comparable to the disorder rate found among children who had been raised by their affected natural parent, suggested that the independent influence (i.e. main effect) of shared environment was of limited importance for this sample of children.

The review suggests several methods for studying genetic transmission in stuttering. However, the results of these studies are not conclusive. Most of the time the condition of the subjects is indirectly tapped which is a major flaw in these studies. The present study investigates genetic transmission in stuttering incorporating both family studies and twin studies.

CHAPTER III

METHOD

Among the four types of data which can give information on the importance of genetic variation in determining who is and who is not susceptible to stuttering (family studies, twin studies, adoption studies and genotyping), family study design and twin study were used in the study.

Subjects

Family study

Twenty-eight families with positive family history for stuttering were selected for the study. Families with stuttering from one to four generations were chosen. The diagnosis for stuttering in the family members was made by a trained speech language pathologist.

Any stutterer with known mental retardation, epilepsy, cerebral palsy or neurological disorders that might be suggestive of generalized neurological dysfunction was not considered for the study. Since gene frequency is a parameter in genetic models and different ethnic groups often have different gene frequencies, only individuals belonging to the Dravidian family will be considered for the study. Subject details are in table 1.

Sl. No	Subject	Age	Gender
1)	A	33	M
2)	B	25	M
3)	Y	21	M
4)	N	21	M
5)	V	21	M
6)	A	45	M
7)	P	23	M
8)	S	5	M
9)	M	20	M
10)	S	29	M
11)	S	15	M
12)	V	28	M
13)	Y	8	M
14)	S	24	M
15)	S	21	M
16)	G	21	M
17)	V	41	M
18)	H	14	M
19)	V	24	M
20)	H	16	M
21)	G	22	M
22)	R	30	M
23)	A	21	M
24)	P	2.6	M
25)	M	21	M
26)	S	25	M
27)	S	24	F
28)	A	23	F

Table 1: Subjects for family study.

Twin study

Two twin studies were undertaken. One set of twins was dizygotic different sex pair and the other was monozygotic same sex pair. The subject details are shown in table 2.

Sl. No	Subject	Age	Gender
1)	ADZ	7	M
2)	L,L MZ	7.6	M

Table 2: Subjects of Twin study.

Procedure

In the family study design, the affected individual identified by the investigator is called the "*proband*". After the proband was selected, information about the family members was obtained using the proband (or parents) as the primary informant ("family history method") or assessing the status of relatives directly (the "family study method") using a questionnaire (Table 3). Detailed information was obtained about the age and nature of onset of stuttering, consanguinity, persistence and recovery of stuttering in families. Pedigree analysis was done. The pedigree included all the first and second-degree relatives of the proband. Standardized symbols were used in the construction of a pedigree as in table 4. Conversation samples of all subjects with stuttering were elicited and audio recorded.

The following questionnaire was employed in the study.

Name :

Age : Gender:

Permanent Address :

Phone Number:

Onset of stuttering - Age :

 Nature:

Pre stuttering incidents : Accidents

 Illness

 Any others

Stuttering characteristics

Pedigree:

Table 3: Questionnaire.

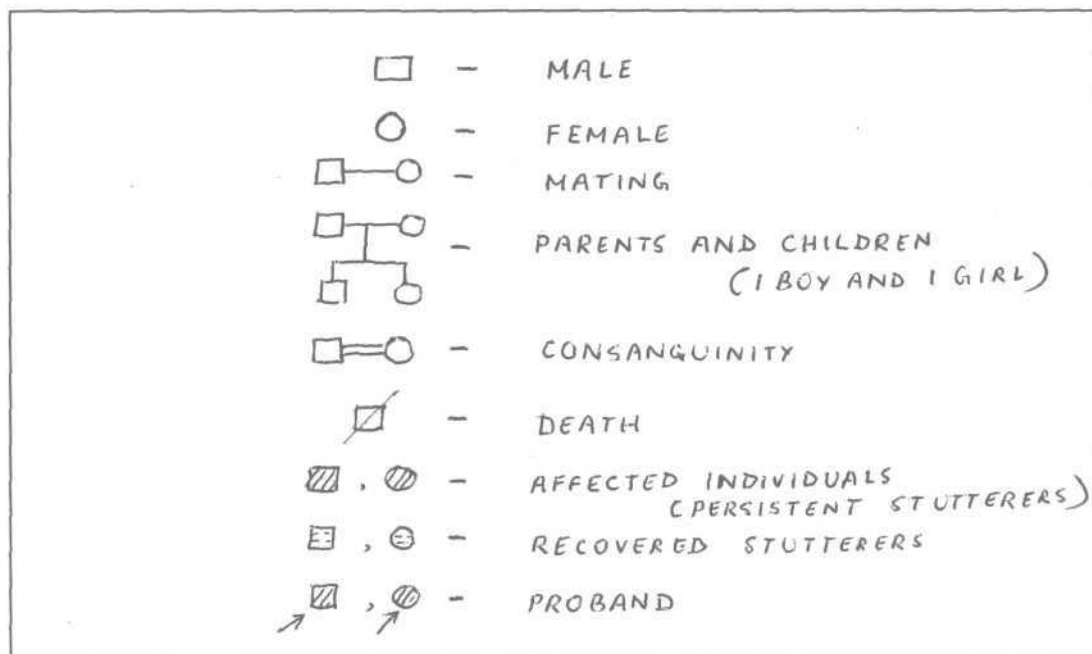

Table 4 : Symbols used in the construction of pedigree.

Analysis

The pedigrees were used to analyze the following areas in genetics of stuttering.

- 1) Pattern of genetic transmission in families,
- 2) Pattern of genetic transmission in twins,
- 3) Male-female ratio in stuttering,
- 4) Consanguinity and genetic transmission of stuttering,
- 5) Persistence and recovery of stuttering as related to heredity,
- 6) Relation between age and nature of onset of stuttering and familiarity in stuttering, and
- 7) Relation between familial stuttering and stuttering severity.

The speech samples were verbatim transcribed to find out percent dysfluencies. Percent dysfluencies was calculated using the following formula:

$$\text{Percent dysfluency} = \text{Number of dysfluencies} * 100 / \text{Total number of words.}$$

Percent dysfluencies were used as a measure of severity of stuttering, which was correlated with familial stuttering.

Attempt was also made to fit the results of the study to any one genetic model of stuttering.

CHAPTER IV

RESULTS AND DISCUSSION

I Pattern of genetic transmission in families

A total of 625 individuals belonging to 30 families were tested. The results revealed 30 probands with family history had 66 relatives who stuttered. Tables 5 and 6 show the distribution of stuttering among first and second-degree relatives.

Relation	No.	% of stuttering	Relation	No.	% of stuttering	Relation	No.	% of stuttering
Father	10	15.2	Grandfather	6	9.09	Cousin brother	9	13.64
Mother	2	3	Grandmother	0	0	Cousin sister	1	15
Brother	6	9.1	Great-grandfather	0	0			
Sister	2	3	Great-grandmother	0	0			
Total	20	30.3		6	9.09		10	15.15

Table 5: Frequency of stuttering among the first- degree relatives.

Relation	No.	% of stuttering	Relation	No.	% of stuttering
Maternal uncle	5	7.58	Grand uncle	6	9.1
Maternal aunt	0	0	Grand aunt	1	15
Paternal uncle	10	15.15	Others	7	10.6
Paternal aunt	1	15			
Total	16	24.2		14	21.2

Table 6: Frequency of stuttering among the second- degree relatives.

The results indicated that the first- degree relatives had a higher percent of stuttering (54.5%) compared to second-degree relatives (45.4%). Among the first-degree relatives, fathers, brothers, grandfathers and cousin brothers had higher percent of stuttering compared to others. Among second-degree relatives, paternal uncles, maternal uncles and grand uncles had high percent of stuttering. Percent stuttering in both first degree and second-degree male and female relatives is shown in table 7.

Gender	First- degree relatives		Second-degree relatives	
	No.	% of stuttering	No.	% of stuttering
Male	31	46.96	28	42.42
Female	5	7.5	2	3
Total	36	54.54	30	45.45

Table 7: percent stuttering in male and female relatives.

Thus, among the first degree relatives, the percent stuttering was as high as 47% in male relatives as against 7.5% in female relatives. Among the second-degree relatives, it was 42.4% and 3% respectively. Figures 3 and 4 show the distribution of percent of stuttering among male and female relatives. The data indicated that males have significantly more percentage of stuttering in both first and second-degree relatives.

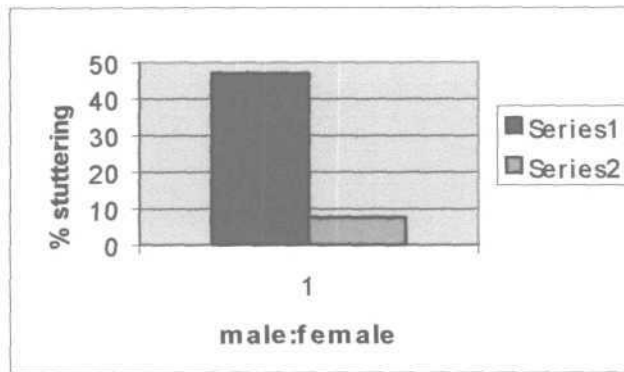

Figure 3: Distribution of stuttering among first-degree relatives.

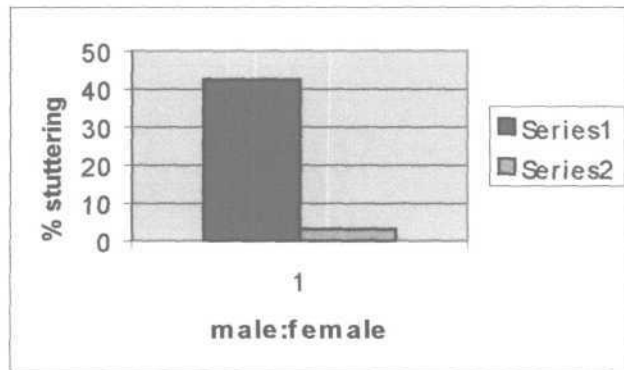

Figure 4: Distribution of stuttering among second-degree relatives.

Tables 8 shows the details of pedigree analysis and figure 5 shows the pedigrees.

S	Age	G	F	M	B	S	GF	GM	GGF	GGM	CB	CS	MU	MA	PU	PA	GU	GA	O
1) A	33	M			*														*
2) B	25	M	*		*						*								
3) Y	21	M	*																
4) N	21	M	•																*
5) V	21	M																	
6) A	45	M			*		*												
7) P	23	M	*		*		*								• **	*			
8) S	5	M															*		
9) M	20	M		*							*	*	*		*				
10) S	29	M			*								*						
11) S	15	M															*		
12) V	28	M					*												
13) Y	8	M															*		
14) S	24	M				**													*
15) S	21	M																	
16) G	21	M	*																
17) V	41	M									•				*				
18) H	14	M													*				*
19) V	24	M	*		*														
20) H	16	M	*														*		
21) G	22	M	*																*
22) R	30	M															*		*
23) A	21	M	*																
24) P	2.6	M					*												
25) M	21	M					*				***								
26) S	25	M													*		*		
27) A DZ	7	M											**						
28) L MZ	7.6	M																	

S	Age	G	F	M	B	S	GF	GM	GGF	GGM	CB	CS	MU	MA	PU	PA	GU	GA	O
27) S	24	F													*				
28) A	23	F		*			*				**		*						

Table 8: Details of pedigree analysis.

F - Father, M - Mother, B - Brother, S - Sister, GF - Grand Father, GM - Grand Mother, GGF - Great Grand Father, GGM - Great Grand Mother, CB - Cuisine Brother, CS - Cuisine Sister, MU - Maternal Uncle, MA - Maternal Aunt, PU - Paternal Uncle, PA - Paternal Aunt, GU - Grand Uncle, GA - Grand Aunt, O - Others
 * - Affected relatives

Subject 1: Age/gender \rightarrow 33y/M

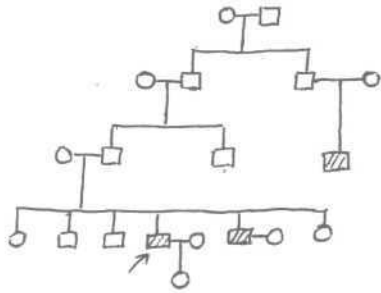

Subject 2: Age/gender \rightarrow 25y/M

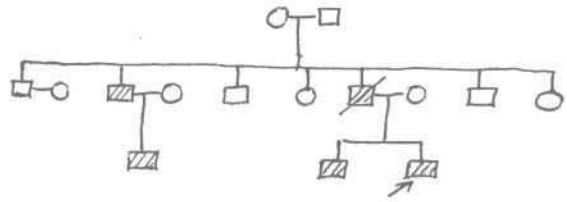

Subject 3: Age/gender \rightarrow 21y/M

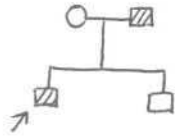

Subject 4: Age/gender \rightarrow 21y/M

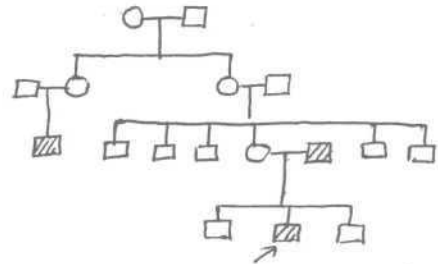

Subject 5: Age/gender \rightarrow 21y/M

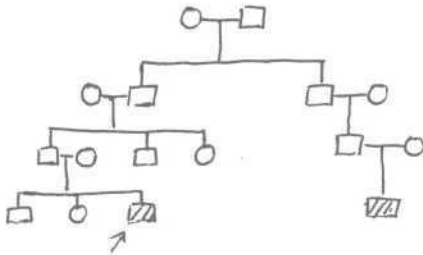

Subject 6: Age/gender \rightarrow 45y/M

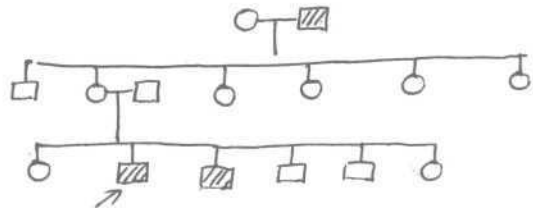

Subject 7: Age/gender \rightarrow 23y/M

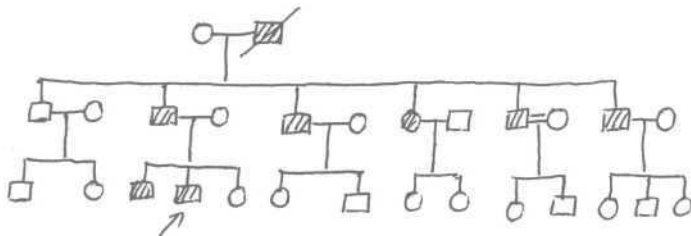

Subject 8: Age/gender \rightarrow 5y/M

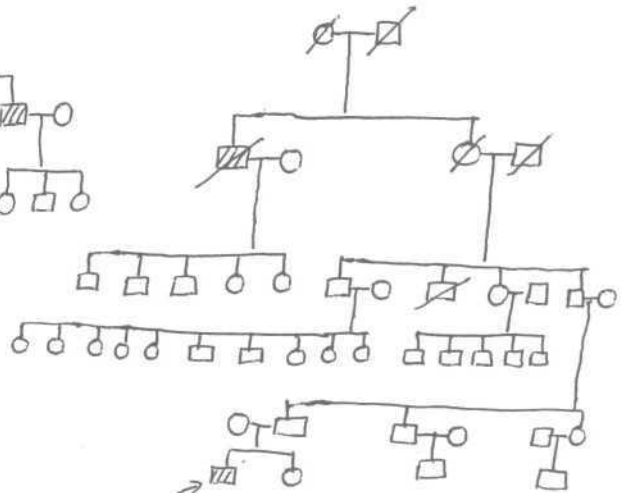

Subject 9: Age/gender \rightarrow 20y/M

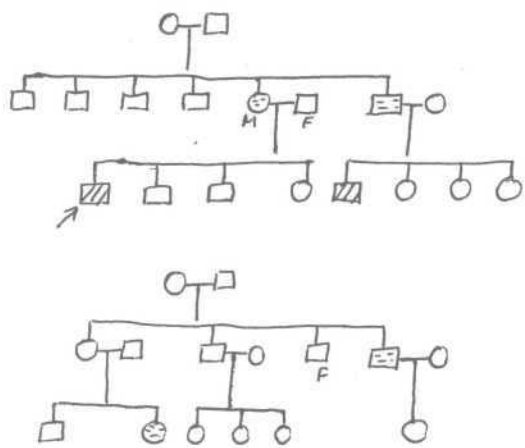

Subject 10: Age/gender \rightarrow 29y/M

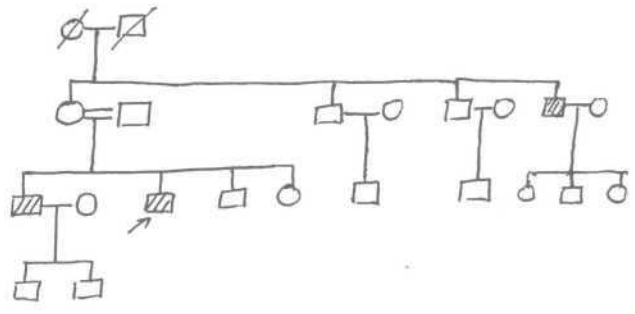

Subject 11: Age/gender \rightarrow 15y/M

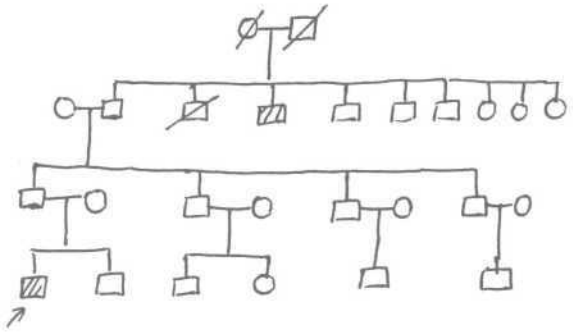

Subject 12: Age/gender \rightarrow 28y/M

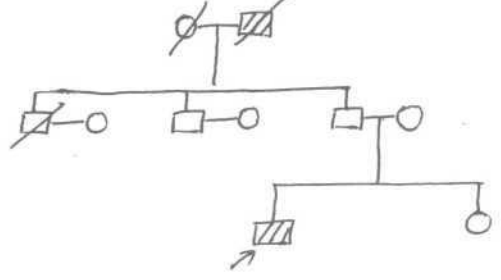

Subject 13: Age/gender \rightarrow 8y/M

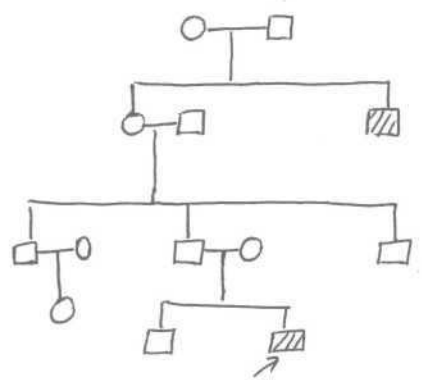

Subject 14: Age/gender \rightarrow 24y/M

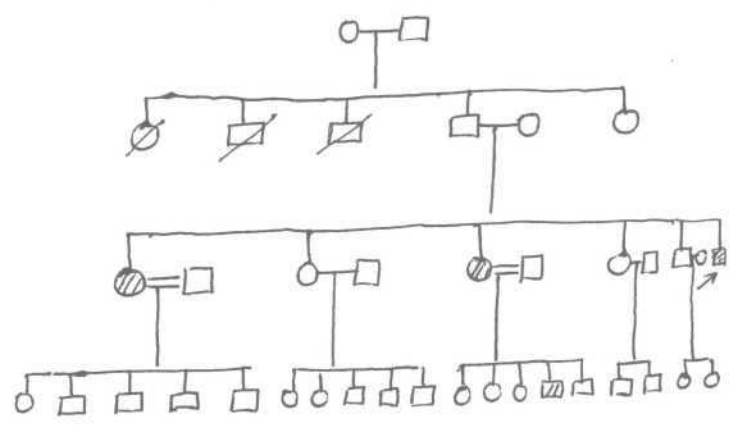

Subject 15: Age/gender \rightarrow 21y/M

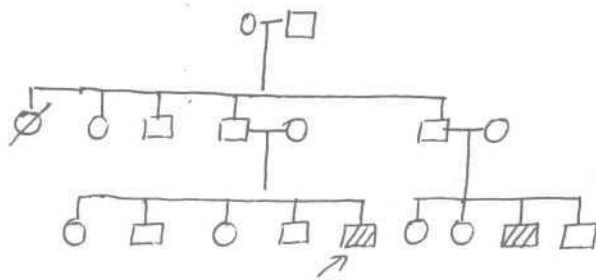

Subject 16: Age/gender \rightarrow 21y/M

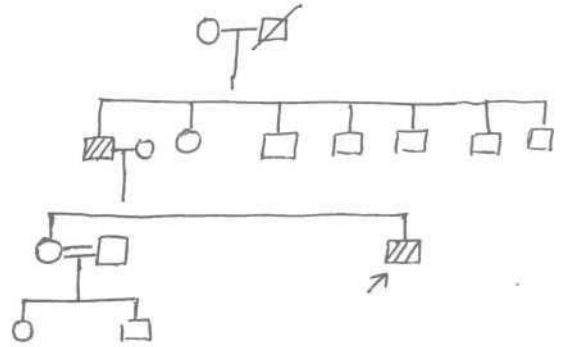

Subject 17: Age/gender \rightarrow 41y/M

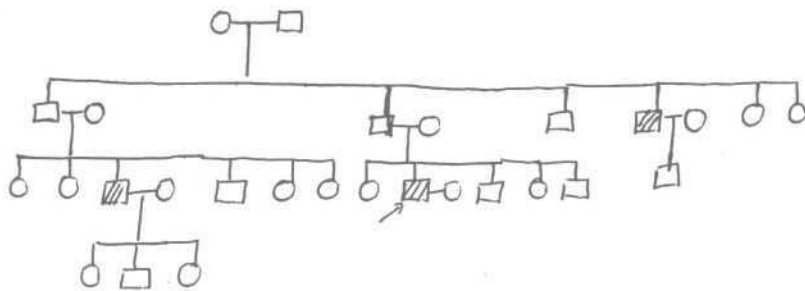

Subject 18: Age/gender \rightarrow 14y/M

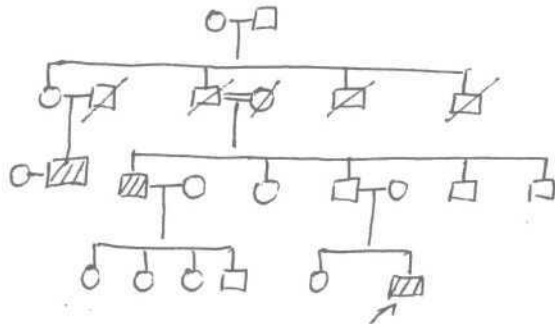

Subject 19: Age/gender \rightarrow 24y/M

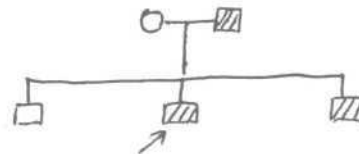

Subject 20: Age/gender \rightarrow 16y/M

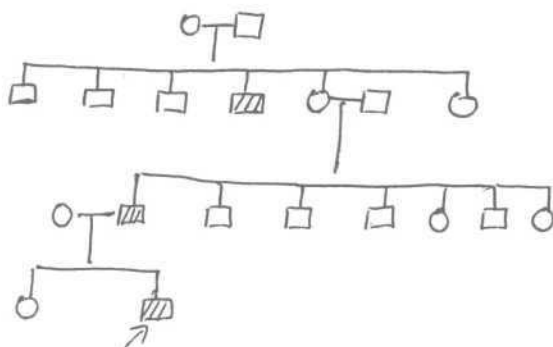

Subject 21: Age/gender \rightarrow 22y/M

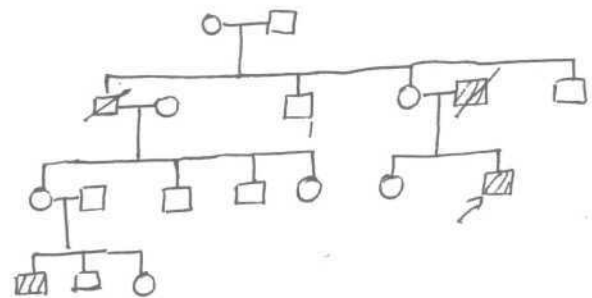

Subject 22: Age/Gender → 30y/M

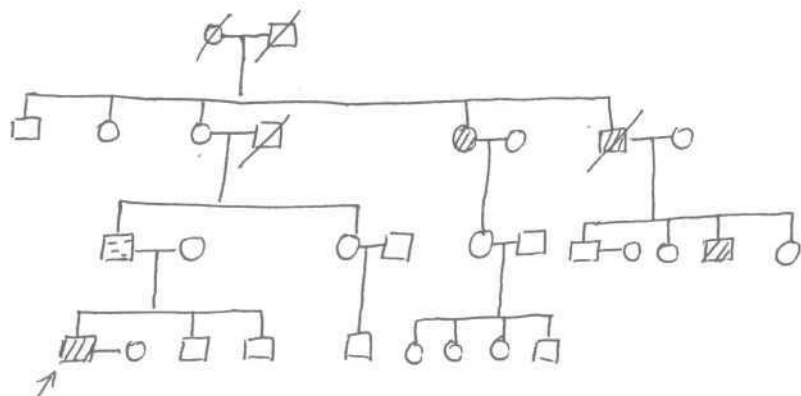

Subject 23: Age/Gender → 21y/M

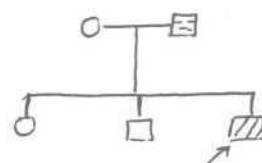

Subject 24: Age/Gender → 2 1/2 y/M

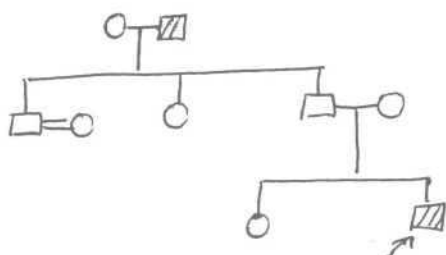

Subject 25: Age/Gender → 21y/M

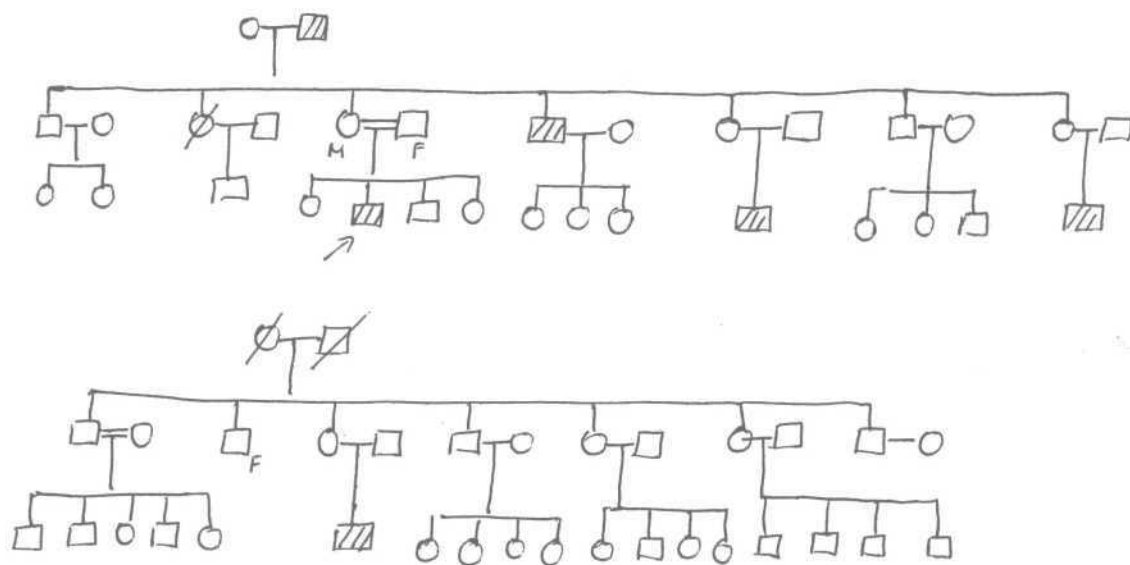

Subject 26: Age/Gender → 25y/M

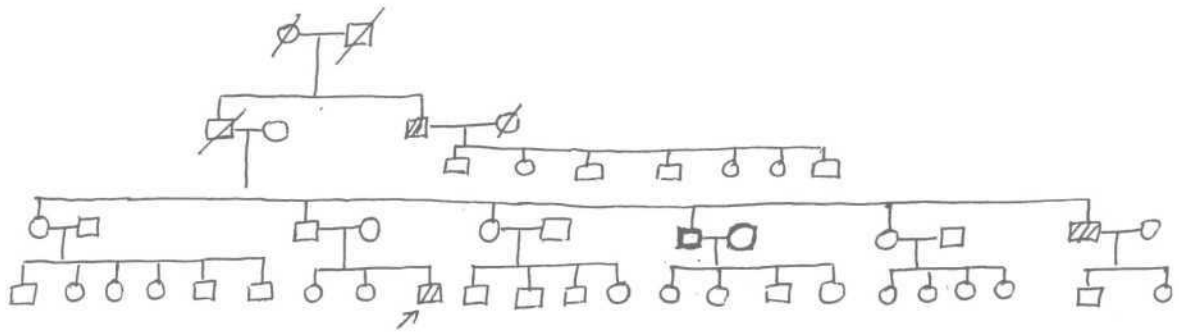

Subject 27: Age/Gender → 24y/F

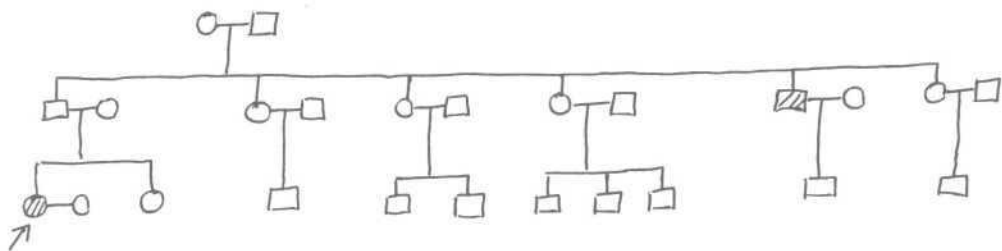

Subject 28: Age/Gender → 23y/F

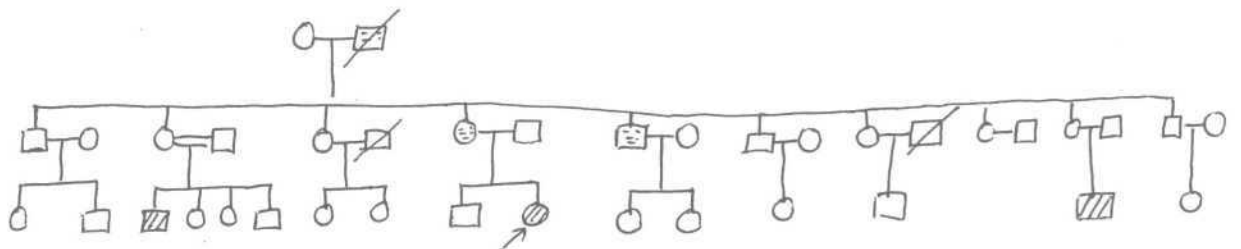

TWIN STUDIES

Subject 1: Age/Gender → 7y/M

Subject 2: Age/Gender → 7.6y/M

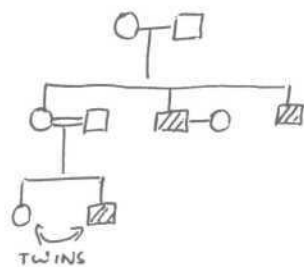

(DIZYGOTIC)

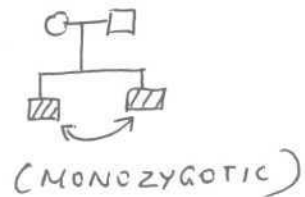

44 (e)

FIGURE 5: PEDIGREES OF ALL THE PATIENTS.

The results indicated a 50% vertical transmission (from father or grandfather) when the proband was a male or female. Further, the data was classified to understand the pattern of genetic transmission from parents (Table 9). The results indicated that the frequency of stuttering increased markedly if the father of the proband also stuttered.

Proband	N	F	M	B
Male	60.7	35.7	3.6	0
Female	50	0	50	0

Table 9: Stuttering in proband's parents
(N-neither parent ever stuttered, F-father ever stuttered,
M-mother ever stuttered, B-both parents ever stuttered).

II Pattern of genetic transmission in twins

Two twin samples were taken for the study. Data obtained is shown in table 10. Both members of the monozygotic pair were concordant for stuttering while the dizygotic pair is discordant for stuttering.

	MZF	MZM	DZF	DZM	DZO
Total no. of twin pairs		1			1
Persons stuttering		Both twins			Only male

Table 10: Details of subjects in twin study
(MZF-monozygotic females; MZM-monozygotic males; DZF-dizygotic female;
DZM-dizygotic male; DZO-dizygotic opposite sex pairs).

III Male to female ratio in stuttering

Male female ratio was 9.7:1 indicating high incidence of stuttering in males.

Table 11 shows male and female ratio.

M	F	M:F
88	9	9.7:1

Table 11: male versus female ratio in stuttering.

IV Relationship between consanguinity and stuttering

Out of thirty families, three families reported consanguinity in parents and seven reported consanguinity in relatives. However, consanguinity does not seem to be related to genetic transmission as no significant difference can be seen in the number of stutterers between consanguineous and non-consanguineous families.

Table 12 shows the relationship between consanguinity and stuttering.

Subjects	Age	G	Consanguinity in parents	Consanguinity in family	No. of relatives who stuttered
1.	33	M	-	-	2
2.	25	M	-	-	4
3.	21	M	-	-	1
4.	21	M	-	-	2
5.	21	M	-	-	1
6.	45	M	-	-	2
7.	23	M	-	+	7
8.	5	M	-	-	1
9.	20	M	-	-	5
10.	29	M	+	-	2
11.	15	M	-	-	1
12.	28	M	-	-	1
13.	8	M	-	-	1
14.	24	M	-	+	3
15.	21	M	-	-	1
16.	21	M	-	+	1
17.	41	M	-	-	2
18.	14	M	-	+	2
19.	24	M	-	-	2
20.	16	M	-	-	2
21.	22	M	-	-	2
22.	30	M	-	-	4
23.	21	M	-	-	1
24.	2.6	M	-	+	1
25.	21	M	+	+	5
26.	25	M	-	-	2
27.	7	M	+	-	2
28.	7.6	M	-	-	1
29.	24	F	-	-	1
30.	23	F	-	+	5

Table 12: Consanguinity in stutterers' family
(g= gender, + indicates presence of consanguinity).

V Persistence and recovery of stuttering

The proportion of persistent stutterers among relatives of male and female probands is significantly higher than the proportion of recovered stutterers. Also, there was a greater proportion of recovered stutterers among the first-degree relatives than among the second-degree relatives in male and female probands. Table 13 gives the percentage of persistent and recovered stutterers in both first and second-degree relatives, for both males and females.

Gender	First-degree relatives		Second-degree relatives	
	P	R	P	R
Male	10.2	1.5	8.9	0.7
Female	8.3	8.3	6.5	3.2

Table 13: Percent of persistence and recovery of stuttering among first and second-degree relatives (P=Persisting, R= Recovered).

VI Relation between age, nature of onset of stuttering and familiarity

It appeared that all children had childhood and gradual onset, except subject 19, who reportedly had onset of stuttering after an accident (following road accident client had lost his consciousness for a day). Table 14 shows the age of onset and nature of onset of stuttering.

Subject	Age	G	Age of onset	Nature of onset
1) A	33	M	Childhood	Gradual
2) B	25	M	9	Gradual
3) Y	21	M	6	Gradual
4) N	21	M	5-6	Gradual
5) V	21	M	6-7	Gradual
6) A	45	M	Childhood	Gradual
7) P	23	M	Childhood	Gradual
8) S	5	M	3-4	Gradual
9) M	20	M	9	Gradual
10) S	29	M	Childhood	Gradual
11) S	15	M	5	Gradual
12) V	28	M	Childhood	Gradual
13) Y	8	M	Childhood	Gradual
14) S	24	M	Childhood	Gradual
15) S	21	M	Childhood	Gradual
16) G	21	M	Childhood	Gradual
17) V	41	M	Childhood	Gradual
18) H	14	M	Childhood	Gradual
19) V	24	M	5	Following accident
20) H	16	M	Childhood	Gradual
21) G	22	M	Childhood	Gradual
22) R	30	M	12	Gradual
23) A	21	M	Childhood	Gradual
24) P	2.6	M	2	Gradual
25) M	21	M	Childhood	Gradual
26) S	25	M	Childhood	Gradual
27) ADZ	7	M	4-5	Gradual
28) LMZ	7.6	M	6.2	Gradual
29) LMZ	7.6	M	6.2	Gradual

Subject	Age	G	Age of onset	Nature of onset
30) S	24	F	Childhood	Gradual
31) A	23	F	5-6	Gradual

Table 14: Age and nature of onset of stuttering (G= Gender).

VI Relation between familial stuttering and severity of stuttering

Percent stuttering in two groups of stutterers was compared. Group I had their fathers or mothers having stuttering and group II had no stuttering in parents. The results indicated an average dysfluency of 20.8% in group I and 30.84% in group II. The results indicated no relation between familial stuttering and severity of stuttering. However, the results should be exercised with caution, as several of the speech samples were obtained at the end or after the termination of therapy. Tables 15 and 16 give percent dysfluency or severity of stuttering in the probands.

S	Age	G	Percent stuttering
1) B	25	M	4
2) Y	21	M	21
3) N	21	M	7
4) P	23	M	6
5) M	20	M	14
6) G	21	M	26
7) V	24	M	23
8) H	16	M	17
9) G	22	M	23
10) R	30	M	54
11) A	21	M	18
12) A	23	F	37
Range			4-54
Average			20.8

Table 15: Percent stuttering in those with stuttering in father/mother.

Subjects	Age	G	Percent stuttering
1) A	33	M	4
2) V	21	M	32
3) A	45	M	3
4) S	5	M	20
5) S	29	M	62
6) S	15	M	9
7) V	28	M	69
8) Y	8	M	7
9) S	24	M	40
10)S	21	M	34
11)V	41	M	76
12)H	14	M	42
13)P	2.6	M	14
14)M	21	M	19
15)S	25	M	91
16) ADZ	7	M	31
17)LMZ	7.6	M	5
18)LMZ	7.6	M	5
19)S	24	F	23
Range			3-91
Average			30.84

Table 16: Percent stuttering in those without stuttering in father/mother.

Discussion

The results of the present study indicated several points of interest. They are discussed under the following headings.

I Familiality and pattern of genetic transmission of stuttering in families

The first-degree relatives had a higher percent of stuttering (54.5%) compared to second-degree relatives (45.4%). This suggests a greater risk for stuttering among the first-degree relatives than among second-degree relatives. This is in accordance with the results obtained by Gupta (2001). Among the first-degree relatives, brothers, grandfathers and cousin brothers had a higher percent of stuttering compared to others. Among the second degree-relatives, paternal uncles, maternal uncles and grand uncles had a high percent of stuttering. This shows that there are more males than females affected among both first and second-degree relatives. This supports the findings of Wingate (1964), Kidd et al., (1981) and MacFarlane et al., (1991) who found greater number of males than females in the families of stutterers.

When the pedigrees are observed, some pedigrees indicate direct transmission (from father or mother) while others indicate indirect transmission (from other family members). Results showed a 50% vertical transmission when the proband was a male. This is in agreement with the results obtained by Kidd et al., (1981). In the present study even for a female, there was 50% vertical transmission.

Also, the transmission of the characteristics of stuttering increases when the father of the proband is also a stutterer (Kidd et al., 1981; Gupta, 2001).

II Pattern of genetic transmission in twins

Results from the two twin samples taken for the study indicates that monozygotic pair was concordant while the dizygotic pair was discordant for stuttering. This supports the earlier findings on higher concordance rates for MZ twins when compared to DZ twins as reported by Howie (1981), Godai et al., (1976), Andrews et al., (1991), Felsenfeld et al., (2000). This gives a strong support for stuttering being a genetic disorder.

III Male to female ratio in stuttering

Combining family studies and twin studies, total number of males with persistent stuttering was 88 when compared to 9 females. These included all relatives of male and female probands and the probands themselves. This gives a male: female ratio of 9.7:1. This shows that males are more susceptible to stuttering than females. This is in concordance with the results obtained by Kidd et al., 1978; Kidd et al., 1981 and Gupta (2001) who report sex effect as high as 6:1(male vs. female). The ratio obtained in this study is higher compared to those obtained in earlier studies. It may be because (a) females are not brought for fluency evaluation, as not importance is given to their speech, or (b) the ratio itself was high in the present study.

IV Relationship between consanguinity and stuttering

The study did not reveal any significant relation between consanguinity and genetic transmission, as there was not much difference seen in the number of stutterers between consanguineous and non-consanguineous families. However, in one family (Subject number 25), which had a high incidence of consanguineous marriages, there were a large number of stutterers.

V Persistence and recovery of stuttering as related to heredity

The results indicated that persistent stutterers among relatives of male probands (19%) was higher than the proportion of recovered (2.3%) stutterers. Also, there was a greater proportion of recovered stutterers among the first-degree relatives (1.5% and 8.3% in males and females, respectively) than among the second-degree relatives (0.7% and 3.2%, males and females respectively).

VI Relation between age and nature of onset of stuttering and familial

Most probands taken for the study reported childhood and gradual onset of stuttering. This gives more support for stuttering to be genetically transmitted in families of these probands. One subject (subject 19) reported stuttering onset after a road accident following which he had lost his consciousness for a day. This subject reported stuttering in the immediate family members, which goes to show that the subject might have been genetically susceptible to stuttering and this could have led

to the manifestation of the disorder following the accident (environmental condition). A special reference to this model is the sex specific threshold model described by Kidd (1930, 1983, 1984) and Kidd et al., (1978) who proposed that stuttering genotypes are expressed as different susceptibilities based on sex. Stuttering threshold is hypothesized to be lower for males. Hence, lesser precipitating (genetic or environmental) factors that contribute to stuttering are sufficient for the disorder to be manifested in males.

VII Relation between familial stuttering and stuttering severity

The results indicated that stuttering severity was significantly much more in probands whose fathers or mothers did not have had stuttering than in probands whose parents had stuttering. This is in agreement with the results of Andrews & Harris (1964) who found that the presence or absence of a positive family history of stuttering did not seem to be significantly related to the severity of stuttering.

The questions to be answered are many. The initial question is whether there is a transmission of stuttering from parent to offspring. The data from the present study shows stuttering is very frequent in these families but don't exclude the possibility that the presence of stuttering has a random pattern in these families. Of the 30 families 11 stutters had either parent stuttering while 19 stutters had neither parent stuttering. Is there really a consistent pattern of transmission within these families? To test the null hypothesis that the pattern is random, the data was divided in to 4 groups as in table 17.

Proband	N	F	M	B	% BS	% SS
Male	60.7			0	22.2	8.7
		35.7	3.6		25	0
Female	50			0	0	0
		0	50		0	0

Table 17: Stuttering in proband's parents (N-neither parent ever stuttered, F-father ever stuttered, M-mother ever stuttered, B-both parents ever stuttered, % BS- % brothers stuttered , % SS - % sisters stuttered).

The frequencies of stuttering among brothers and sisters show a remarkable difference. If neither parent of the male proband ever stuttered, 22.2% of the brothers stuttered and 8.7% of the sisters stuttered. But, if the father had stuttered, the frequency was 25.0 % and 0%, respectively. In case of female proband the frequency was 0%.

A variety of hypotheses, both cultural and genetic, might be considered to explain the transmission. The simple possible model of cultural transmission is *mimicry*. Most of the stutters in these pedigrees do not have a parent who stuttered. Even among those who had a parent who stuttered, in over 6% of the cases parent had achieved normal fluency. In those families there was no pattern of stuttering *per se* that could have been learned and mimicked. Mimicry is a simplistic hypothesis of transmission and about 40 % of stutters had a parental role model that they could mimic. Any model that can explain only 40% of the cases does not deserve much weight. No other cultural transmission hypotheses have been tested because it has not been possible to formulate other quantifiable cultural hypotheses.

In approaching the genetics of stuttering several different genetic hypotheses have been considered. Two specific ones will be discussed; both of them explain the data and yet are extremely different.

The first model is the multifactorial-polygenic model. According to this model, the genetic susceptibility is inherited as a function of many gene and each one of these genes contribute only a very small amount. The population distribution for this underlying susceptibility is basically a bell-shaped curve. In addition to an individual's susceptibility, there are physiological or developmental thresholds such as individuals who have a susceptibility above that threshold are affected. In addition to the genetic components determining this distribution, there are nongenetic components. One of the measures of the degree of genetic vs. nongenetic components is the degree of displacement of the distribution for relatives from the mean of the population. Relatives of an unaffected proband are displaced upwards, on an average, if there is a genetic component to susceptibility. The physiological threshold remains the same so that there is a higher proportion of relatives affected than one would expect for unrelated individuals in the general population. It has already been seen that in stuttering the percentage of relatives who stutter is much higher than in the general population. The multifactorial-polygenic model can be made more appropriate for stuttering by specifying different thresholds for two sexes. Kidd (1977) analyzed the sex-specific model and gave the following predictions: (a) the parent-offspring correlation and the sibling correlation are 38%, (b) the predicted male lifetime prevalence is about 4%, and (c) the female lifetime prevalence is 2%. In the present study the parent-offspring correlation is 27.2% and

the sibling correlation is 16.6 %. These factors in the multifactorial-polygenic model give a very good fit to the available data.

The other model is the single major locus model. One gene locus with two alleles gives rise to 3 genetic types: homozygotes for the normal allele, heterozygotes, and homozygotes for stuttering allele. The non genetic factors are hypothesized to affect the distribution of susceptibility around the mean of each genotype. Thus, the model has the same sort of susceptibility scale as the multifactorial-polygenic but each genetic type has a different average liability. The frequencies of the genetic types are determined by the allele frequencies. A threshold is postulated and individuals above the threshold are affected, irrespective of their genetic constitution. Hence, in this model even normal individuals, if they have a sufficiently exacerbating environment, can be affected, whereas carriers of the gene, if they have sufficiently ameliorating environment, can be unaffected. When this model is applied to the data the results were as in table 18. Figure 6 shows the fit of the data to the model. The results predict that the frequency of stuttering is about 15.52%. The proportion of individuals with a specific genetic type who actually manifest stuttering is called the *penetrance for that genotype*. The model predicts very low penetrance values for the homozygous normals and very high penetrance values for homozygotes for the hypothetical stuttering gene - homozygotes are always affected whether male or female. The gender effect and all of the environmental effects are manifest in the penetrances of the heterozygote, the individuals who have both types of genetic information. However, no good data are available for these predictions.

	Total population	No. of stutters	No. of nonstutters	Percent of stuttering
Males	329	88	251	26.7
Females	296	9	287	3.0
Total	625	97	538	15.52

Table 18: Fit of the single-major-locus model to the family incidence data on stuttering.

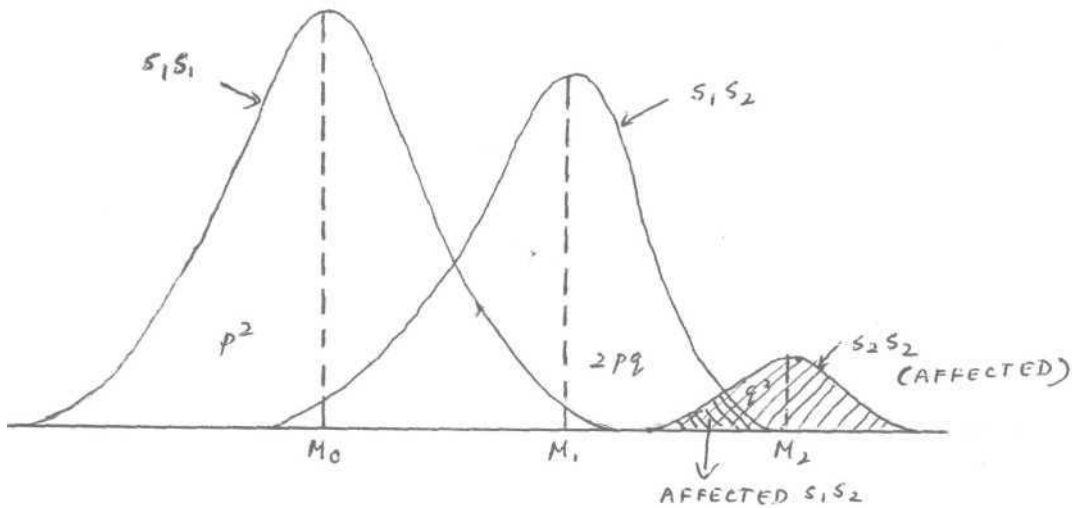

Figure 6: Fit of the data to the single major locus model.

The differences in gene type frequencies between male and female stutters can help explain the transmissional aspects of stuttering. A female stutters is much more likely to carry the stuttering gene. A female to be a stutters must have received the gene from both parents proportionately more often than a male, and

hence will proportionately more often transmit the gene to all children. Though the model initially considers all stuttering as the same, it nonetheless predicts a sort of heterogeneity among stutters.

Though the understanding of the genetic aspects of stuttering is not definitive, these analyses have implications for research into the causes of stuttering. Future work can consider separately transient childhood stuttering and stuttering that persists into adulthood. Further, the statistics behind the genetic models are very simple and ignore some potentially useful information in the data. Better statistics and biologically more realistic models are required.

Also, very important will be the data more closely reflecting the particular inherited susceptibility. Information on laterality and on some response to dichotic listening tasks within families will be potentially useful. It may be that in some families there exists a clear genetic pattern of abnormal cerebral processing that does not always result in stuttering but, at least in those families, is always necessary for stuttering to develop.

The results emphasize that gender is a vital factor. Research and treatment of stuttering must consider the gender of the patient. The results also demonstrate that transmission of stuttering exists which can be explained with genetic hypothesis. Finally, the results point out that research on stuttering, as in many other types of research on human disorders, a genetic perspective is essential.

CHAPTER V

SUMMARY AND CONCLUSIONS

In the present study, thirty families were taken up to investigate the role of genetic factors in stuttering. Twenty-eight families reported history of stuttering in first and second-degree relatives. Two twin samples were taken, one comprising of monozygotic twins and the other dizygotic twins. The study investigated the following:

- 1) The pattern of genetic transmission in families.
- 2) The pattern of genetic transmission in twins.
- 3) Male female ratio in stuttering.
- 4) Relation between consanguinity and stuttering.
- 5) Relation between persistence and recovery of stuttering and familiarity.
- 6) Relation between age, nature of onset of stuttering and familiarity.
- 7) Relation between familial stuttering and stuttering severity.

Data was obtained from the families on all the above aspects and pedigrees were constructed. The speech samples of all the probands was collected and verbatim transcribed.

Results of the study indicated the following:

- a) Risk of stuttering is greater in close/ first-degree relatives (54.5%) compared to second-degree relatives (45.4%). Also, stuttering among relatives occur in

a pattern indicating vertical transmission of a susceptibility to stutter with sex-modified expression.

- b) There is greater concordance for the disorder among monozygotic than among dizygotic twins.
- c) In families with positive family history for stuttering, males (88) are genetically more susceptible to stuttering than females (9) (9.7:1).
- d) There was no correlation between consanguinity and genetic transmission of stuttering.
- e) The proportion of persistent stutters (19%) among relatives of male probands was higher than the proportion of recovered stutterers (2.3%)
- f) Stuttering if familial tends to be of relatively early and gradual onset.
- g) Stuttering severity and familial stuttering doesn't seem to have any relationship.

Each of these hypotheses is consistent with the hypothesis of genetic transmission, but none can rule out a significant role of non-genetic factors. The multifactorial-polygenic model and the single locus model can be applied to the findings of the study. Fitting the data into the single-locus model predicts the incidence of stuttering to be 15.52%. Thus, genetic susceptibility possibly necessary, but certainly not sufficient, is a major factor in stuttering. Moreover, females are more resistant to an inherited susceptibility to stuttering than males.

Implications for future research

The next step in this investigative sequence requires molecular analyses from high density pedigrees so that, the location of a candidate major gene, if one exists, can begin to be isolated. Once, such a gene is found, then its functions and products can be identified, thereby increasing the probability that appropriate remediative measures (e.g. Pharmacological treatments) may be developed. Future studies must collect blood, neurochemical and detailed phenomenological data from the proband subjects and their family members so that sensitive behavioral or molecular comparisons can be initiated.

The most important area to be addressed is the assessment of phenotype. In addition to assessing carefully, the proband, all members of the family need to be evaluated personally. It is critical in a family study to know every person who has stuttered at some period in his or her lives. Only with data like these, will it be possible to test with confidence, specific genetic hypotheses.

REFERENCES

- Ambrose, N. G., Cox, N., & Yairi, E., (1997). The genetic basis of persistence and recovery in stuttering. *Journal of Speech, Language and Hearing Research*, 40, 567-580.
- Ambrose, N., Yairi, E., & Cox, N., (1993). Genetic aspects of early childhood stuttering. *Journal of Speech and Hearing Research*, 36, 701-706.
- Andrews, G., & Harris, M.(1964). *The syndrome of stuttering*. Clinics in developmental medicine, No. 17. London: Spastics Society Medical Education and Information Unit.
- Andrews, G., Morris-Yates, A., Howie, P., & Martin, N. (1991). Genetic factors in stuttering confirmed. *Archives of General Psychiatry*, 48, 1034-1035.
- Berry, M. F. (1937b).Twinning in stuttering families. *Human Biol*, 9, 229-46.
- Berry, M. F., (1938). A common denominator in twining and stuttering. *Journal of Speech Disorders*, 3, 51-57.
- Bloodstein, O. (1993). *Stuttering: the search for a cause and cure*. Boston: Allyn and Bacon.
- Cox, N, Kramer, P., & Kidd, K. (1984a). Segregation analysis of stuttering. *Genetic epidemiology*, 1, 245-253.
- Cox, N., & Kidd, K (1983). Can recovery from stuttering be considered a genetically milder subject of stuttering? *Behavior Genetics*, 13, 129-139.
- Cox, N., Seider, R., & Kidd, K. (1984b). some environmental factors and hypotheses for stuttering in families with several stutterers. *Journal of Speech and Hearing Research*, 27, 543-548.
- Crittenden, L. B. (1961). An interpretation of familial aggregation based on multiple genetic and environmental factors. *Annals of the New York Academy of Sciences*, 91,769-782.
- Falconer, D. S. (1965). The inheritance of liability to certain diseases estimated from the incidence among relatives. *Annals of Human Genetics (London)*, 29, 51-76.
- Felsenfeld, S. (1996). Progress and needs in the genetics of stuttering. *Journal of Fluency Disorders*. 21, 77-103.
- Felsenfeld, S., Kirk, K., Zhu, G., Statham, D., Neale, M., & Martin, N(2000). A study of the genetic and environmental etiology of stuttering in a selected twin sample. *Behavior Genetics*. Submitted manuscript.

- Gladstein, K. L., Seider, R. A., & Kidd, K.K. (1981). Analysis of sibship patterns of stutterers. *Journal of Speech and Hearing Research*, 24, 460-462.
- Godai, U., Tatarelli, R., & Bonnani, G., (1976). Stuttering and tics in twins. *Acta Geneticae Medicae et Gomellologiae*, 25, 369-375.
- Graf, O. I. (1955). *Incidence of stuttering among twins*. In W. Johnson(Ed.). Stuttering in children and adults. Minneapolis: University of Minnesota Press.
- Gray, M. 1940. The X family: A clinical and laboratory study of a "stuttering" family. *Journal of Speech and Hearing Disorders*, 5, 343-348.
- Gupta., (2001). Stuttering and Genetics- some investigations. *Journal of Indian Speech and Hearing Association*, 15, 21-26.
- Gusella, J.F., Wexlet, N.S., Conneally, P.M., Naylor, S.L., Anderson, M.A., Tanzi, R.E., Watkins, P.C., Ottina, K., Wallance, M.R., Sakaguchi, A.Y., Young, A.B., Shoulson, I., Bonilla, E. and Martin, J.B. (1983). A polymorphic DNA marker genetically linked to Huntington's disease. *Nature*, 306, 234-238.
- Helms, C, Green, P., Weiffenbach, B., Bowden, D., Keith, T., Stephens, K., Smith, D., Akots, G., Bricker, A., Brown, V., Gravius, T., Morgan, D., Muller-Kahle, H., Phipps, P., Rising, M., Rediker, K., Powers, J., Falls, K., Hogan, C, Cannizzaro, L., & Donis-Keller, H. (1988). A human genetic map with 545 genetic loci. *American Journal of Human Genetics*, 43, (Supplement), A147.
- Howie, P. (1981a). Concordance for stuttering in monozygotic and dizygotic twin pairs. *Journal of Speech and Hearing Disorders*, 24, 317-321.
- Howie, P. M. (1981). A twin investigation of the etiology of stuttering. *Journal of Speech and Hearing Research*, 24, 317-321.
- Johnson, W., Boehmler, R., Dahlstrom, W., Darley, F., Goodstein, L., Kools, J., Prather, W., Sherman, D., Thurman, C, Trotter, W., Williams, D., & Young, M. (1959). *The onset of stuttering*. Mineapolis: University of Minnesota Press.
- Kay, D. W. K. *The genetics of stuttering* (1964). In G. Andrews & M.M. Harris (Eds). The syndrome of stuttering. London: William Heinemann Books.
- Kidd, K.K. (1977). A genetic perspective on stuttering. *Journal of Fluency Disorders*, 2, 259-269.
- Kidd, K. K.(1980).Genetic models of stuttering. *Journal of fluency disorders*, 5, 187-201.
- Kidd, K. K.(1984). Stuttering as a genetic disorder. In R. Curlee & W. Perkins(Eds.). *Nature and treatment of stuttering*, San Diego, CA:College Hill, 149-169.

Kidd, K. K., Heimbuch, R., & Records, M.(1981). Vertical transmission of susceptibility to stuttering with sex-modified expression. *Proceedings of the National Academy of science*, 78, 606-610.

Kidd, K. K, Kidd, J.R., & Records, M. (1978). The possible causes of sex ratio in stuttering and its implications. *Journal of Fluency Disorders*, 3, 13-23.

Kidd, K. K., Oehlert, G., Heimbuch, R., Records, M., & Webster, R. L. (1980). Familial stuttering patterns are not related to one measure of severity. *Journal of Speech & Hearing Research*, 23, 539-545.

Kidd, K. K., Reich, T., and Kessler, S., (1973). *Genetics*, 74, No. 2, Part 2: s137.

Kidd, K. K., Reich, T., and Kessler, S., (1974). Genetic Analysis of stuttering. Unpublished Manuscript.

MacFarlane, W., Hanson, M., & Walton, W. (1991). Stuttering in five generations of a single family. *Journal of Fluency Disorders*, 16, 117-123.

Meyer, B. (1945). Psychosomatic aspects of stuttering. *Journal of Nervous Mental Disorders* 707:127-157.

Morton, N. E., & MacLean, C. J. (1974). Analysis of family resemblance, III: Complex segregation of quantitative traits. *American Journal of Human Genetics*, 26, 489-503.

Nelson, S. F., Hunter, N., & Walter. M. (1945). Stuttering in twin types. *Journal of Speech Disorders*, 10, 335-343.

Orvaschel, H., Thompson, W.D., Belanger, A., Prusoff, B.A. & Kidd, K.K. (1982). Comparison of the family history method to direct interview : Factors affecting the diagnosis of depression. *Journal of Affective Disorders*, 4, 49-59.

Pauls, D.L., Kruger, S.D., Leckman, J.F., Cohen, D.J., & Kidd, K.K. (1984). The risk of Tourette's syndrome and chronic multiple tics among relatives of Tourette's syndrome patients obtained by direct interview. *Journal of the American Academy of Child Psychiatry*, 23, 134-137.

Pauls, D. (1990). A review of the evidence for genetic factors in stuttering. *Asha Reports*, 18, 34-38.

Plomin, R., DeFries, J. C, & MacLean, G.E. (1980). *Behavioral genetics: a primer*. San Fransisco: Freeman

Seider, R.A., Gladstein, K & Kidd, K.K.(1983). Recovery and persistence of stuttering among relatives of stutterers. *Journal of Speech and Hearing Disorders*, 48, 402-409.

Van Riper, C. (1971). *The nature of stuttering* (1st ed.). Englewood Cliffs, NJ: Prentice- Hall.

Van Riper, C. (1982). *The nature of stuttering*. Englewood Cliffs, NJ: Prentice- Hall.

Vandenberg, S.G., Singer, S. M., & Pauls, D. J. (1986). *The heredity of behavior disorders in adults and children* (pp. 231-235). New York: Plenum Medical Book Company.

Wepman, J. M. (1939). Familial incidence of stammering. *Journal of speech Research, 4*, 199-204.

West, R., (1958). An agnostic's speculations about stuttering. In Eisenson, J. (Ed.). *Stuttering: A symposium*. New York: Harper & Row.

West, R., and Ansberry, M., (1968). *The Rehabilitation of Speech*, 4th ed. New York: Harper & Row.

West, R., Nelson, S., & Berry, M.(1939). The heredity of stuttering. *Quarterly Journal of Speech, 25*, 23-30.

Wingate, M. E. (1964). Recovery from stuttering. *Journal of Speech and Hearing Disorders, 29*, 312-21.