

A GUIDE FOR THE HEARING AID USER

Reg. No.M8923

AN INDEPENDENT PROJECT WORK SUBMITTED IN PART FULFILMENT  
FOR FIRST YEAR M.SC., (SPEECH AND HEARING) TO THE UNIVERSITY  
OF MYSORE.

ALL INDIA INSTITUTE OF SPEECH AND HEARING: MYSORE - 570 006

MAY 1990.

TO DEAREST

AAI AND BABA

TO WHOM I OWE EVERYTHING

**CERTIFICATE**

This is to certify that the Independent Project entitled: A GUIDE FOR THE HEARING AID USER is the bonafide work in part fulfilment for the Degree of Master of Science (Speech and Hearing) of the student with Register Number M8923.

Mysore  
May, 1990



**Director**

All India Institute of  
Speech and Hearing  
Mysore-6.

**CERTIFICATE**

This is to certify that this Independent Project entitled: A Guide for the Hearing Aid user has been prepared under my supervision and guidance.

Mysore  
May, 1990

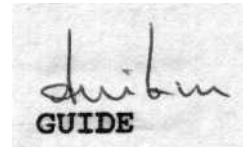
A rectangular stamp containing a handwritten signature in cursive script above the word "GUIDE" printed in a bold, sans-serif font.

### DECLARATION

This Independent Project entitled: A Guide For The Hearing Aid User is the result of my own work undertaken under the guidance of Dr.(Miss) S. Nikam, Prof, and HOD, Department of Audiology, All India Institute of Speech and Hearing, Mysore, and has not been submitted earlier at any University for any other Diploma or Degree.

Mysore  
May, 1990

Register No.M8923

## ACKNOWLEDGEMENTS

My grateful thanks to Dr.(Miss) S.Nikam, Prof, and HOD, Department of Audiology, All India Institute of Speech and Hearing, Mysore, without whose valuable guidance and constant encouragement, this project would not have seen light.

My sincere thanks to the Director, A.I.I.S.H. Mysore, for extending the facilities to carry out this project.

My special thanks to -

- Mrs. Roopa, N. for providing information for my project.
- Mythru, Jyoths, Yam, sonu for the timely help in solving my innumerable queries.
- My other friends who raised my spirits through and through.
- My family members for the moral support and encouragement.
- Rajalakshmi Akka for bearing the torture of trying to comprehend my illegible handwriting and typing out my project with great patience.

## TABLE OF CONTENTS

<u>Chapter</u>	<u>Page No.</u>
INTRODUCTION	- 1 - 3
HEARING AID: AN AID FOR THE HEARING IMPAIRED.	- 4 - 7
COMPONENTS OF A HEARING AID	- 8 - 36
- Microphone	- 8
- Amplifier	- 12
- Receiver	- 13
- Cell	- 19
- Earmold	- 27
- Cord	- 31
- Volume control	- 33a
- On-off switch	- 35
ACCESSORIES OF THE HEARING AID	- 37 - 40
- Tone control	- 37
- Telecoil	- 39
DECIBEL	- 41 - 44
ELECTROACOUSTIC CHARACTERISTICS OF HEARING AID	- 45 - 60
- Gain	- 45
- Frequency-response	- 54
- Frequency range	- 56
- Saturated sound pressure level or maximum output level (SSPL)	- 57
- Equivalent input noise level	- 58
- Distortion	- 58
GUIDELINES FOR PURCHASE OF HEARING AID	- 61 - 72
SUMMARY	- 73
BIBLIOGRAPHY	- 74 - 77

## INTRODUCTION

It is in YOUR hands!!

Every handicap can be prevented from being a disability. Management methods have been developed for every kind of handicap. Through these methods, the deficiencies, sensory or motor can be compensated. For example - 'Spectacles' have been the major line of management in case of visual impairment. Similarly, in case of hearing impairment the major advancement in management has been in developing listening devices, namely, 'hearing aids'.

Of course, the management of hearing impairment varies according to the type and degree of hearing impairment. Management could be either medical or rehabilitative as in the case of reversible or irreversible cases of hearing impairment, respectively.

Just as in case of visual impairment where the selection of appropriate spectacles involves a systematic procedure, so is the case in the selection of a hearing aid. In other words, selection of a hearing aid depends upon several factors including the degree of hearing loss.

Hearing aid selection is a complex process. It cannot be selected considering just the cosmetic value or the price



tag. It is meant for a purpose! Hence, it becomes necessary that all the necessary aspects such as the degree of hearing loss, nature of hearing loss and its typical characteristics in each individual be strictly considered while rehabilitating the hearing impaired individual.

'Hence, for efficient use of hearing aid, it becomes important, that both the clinician and the beneficiary be well informed regarding the various aspects of hearing aids and functions. This in turn will aid in the maintenance and purposive use of a hearing aid, the goal being successful rehabilitation of the hearing-impaired.

Among other aspects, information on the electroacoustic characteristics of hearing aid is important for the user to have, for several reasons. A hearing aid user must know that he has a hearing aid appropriate for his needs.

Electroacoustic characteristics refer to the input-output performance of hearing aids i.e. comparing the parameters of the original sound which is presented to the hearing aid and parameters of the same sound which is recorded from the hearing aid.

A knowledge about the electroacoustic characteristics helps -

1. In knowing the performance expected of a hearing aid prior to use.
2. In differentiating among different classes of hearing aids viz. mild, moderate and strong.
3. In knowing about the performance during use and if the characteristics have changed subsequent to use.
4. In knowing the performance of a hearing aid after repair and noting changes, if any.
5. In procuring the appropriate hearing aid, appropriate to meet as prescribed by the professional (audiologist)..

It is not just the name or brand of the hearing aid according to which a hearing aid is prescribed, but a hearing aid with certain performance characteristics is important as the user is concerned. 'So, to know whether the hearing aid is functioning well or not, it is better to find out and have information about the electroacoustic characteristics of the hearing aid in question.

And, for efficient use of a hearing aid, it is better to know about different parts of the hearing aid and their functions..

### HEARING AID : AN AID FOR THE HEARING-IMPAIRED

A hearing aid is an instrument that presents sounds more effectively to the listener's ears. It collects sounds from the environment, amplifies them and feeds to the listener's ears. It will help to hear speech or other environmental sounds, by making them louder to the extent at which user can comfortably hear them. So, it is recommended for the use of people with hearing loss.

Thus, the function of a hearing aid is to increase the loudness of the sounds, so that they become available to the user. A hearing aid does not improve the hearing capacity of the user, it just makes the user able to hear sounds. A hearing aid cannot be a substitute for a normally functioning ear.

Those types of hearing impairments which cannot be helped by any medication or surgery can be helped by means of a hearing aid.

The day-to-day communication of a deaf person is affected without a hearing aid, as he loses contact with the environment.

Hearing aid is useful in both unilateral and bilateral hearing loss cases. Unilateral meaning hearing impairment in one ear and bilateral meaning hearing impairment in both ears.

Hearing aid users must know important parts and basics of hearing aid operation, for effective usage of their aid for longer periods of time.

Hearing aid can be used for a child who is deaf since birth. It enables such children to learn to hear speech and other environmental sounds around them. It can also be used for those people who have acquired post-lingual hearing loss i.e. the cases, in which hearing loss occurs after they have learnt to talk. Hearing aid brings them back to the hearing world.

So, a hearing aid improves the loudness of speech and other environmental sounds.

There are two major types of hearing aids - body level hearing aid, and ear-level hearing aid (BTE).

- Body level hearing aids are worn on the body, either in a shirt pocket or special harness or clipped to the clothing. A wire(cord)runs from the aid to the receiver at the ear. They are most often rectangular in shape.

- Ear level hearing aids rest behind the pinna with a plastic tube, instead of a wire(cord).

How does a body worn hearing aid look?

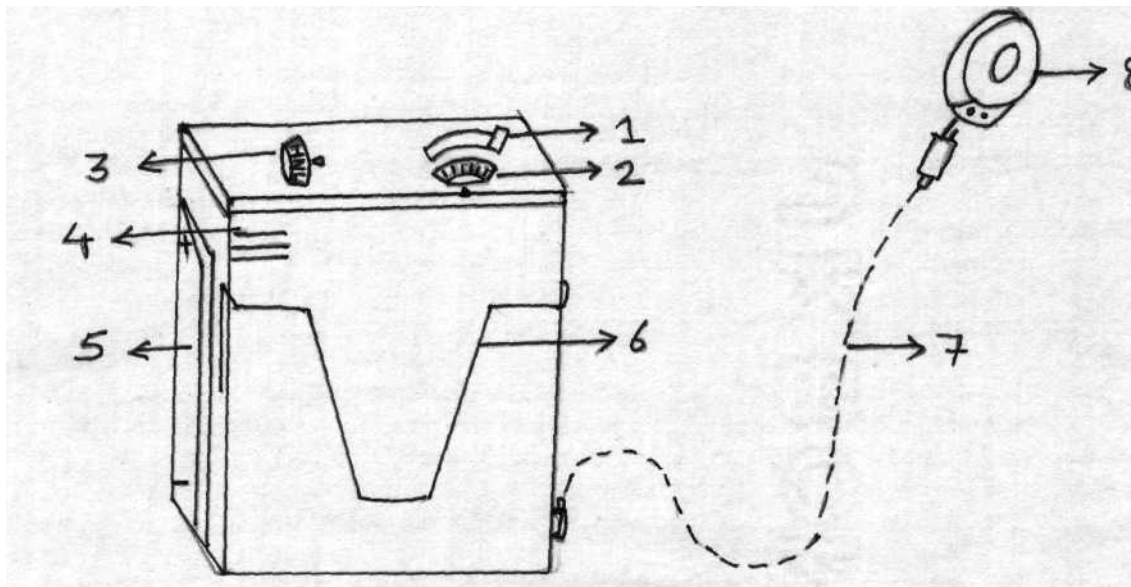

- |                        |             |
|------------------------|-------------|
| 1. On-off switch       | 6. Clip     |
| 2. Volume control      | 7. cord     |
| 3. Tone control        | 8. Receiver |
| 4. Microphone          |             |
| 5. Battery compartment |             |

How does a behind the ear hearing aid look?

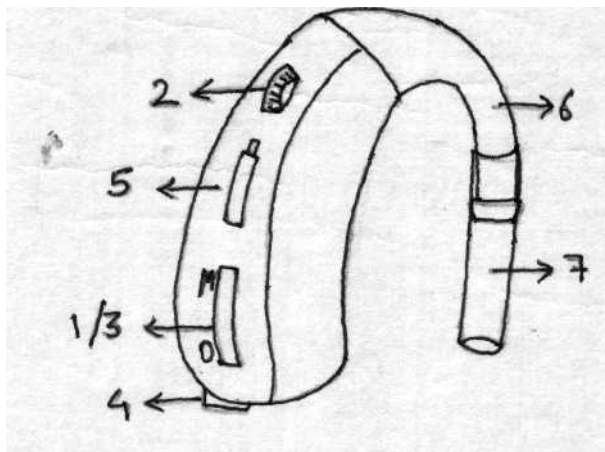

- |                        |
|------------------------|
| 1. On-Off switch       |
| 2. Volume control      |
| 3+ Tone control        |
| 4. Microphone          |
| 5. Battery compartment |
| 6. Hook                |
| 7. Plastic tube        |

A hearing aid has many components. They are -

- Microphone
- Power supply (Battery)
- Amplifier
- Receiver.

**Microphone:** It picks up sounds from the environment, changes it into the electrical signal and passes it to the next part i.e. amplifier.

**Amplifier:** It amplifies i.e. increases loudness of the sound with the help of power supply from the battery.

**Receiver:** As the name indicates, it receives the amplified electrical signal from the amplifier, converts it into sound signal and sends to the listener's ears.

**Power supply (Battery):** As in radio and T.V., battery helps in functioning of the hearing aid. It helps the amplifier to increase the level of the sounds reaching the ear.

How sounds travel through the hearing aid to the user's ear?

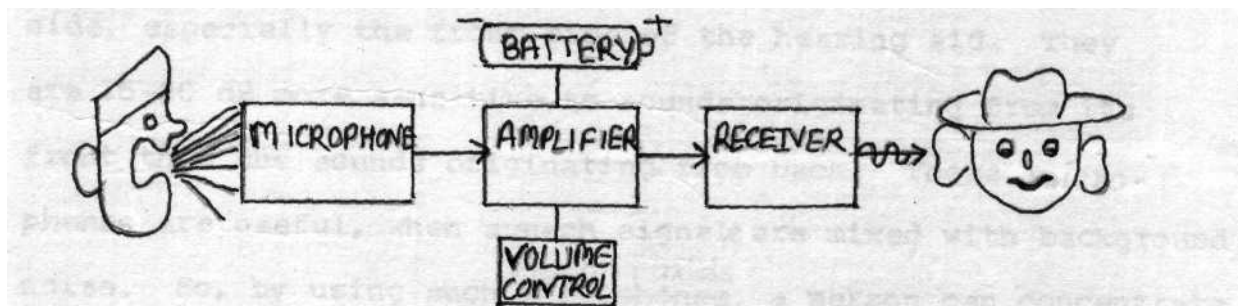

The other parts of a hearing aid are - Earmold, cord, volume control, on-off switch. Accessories of a hearing aid are - tone control, telecoil.

## COMPONENTS OF A HEARING AID

### MICROPHONE:

Microphone is an important and delicate part of the hearing aid.

It is a device that converts acoustic (sound) energy into electrical energy.

Microphone picks up the sounds from the environment, which are then converted into electrical energy. This electrical energy is then passed further, for the process of amplification.

Location of the microphone in the hearing aid is important because the sounds closest to the microphone are picked up most readily.

### Types of microphones:

Directional - These microphones pick up sounds only from one side, especially the front side of the hearing aid. They are 15-20 dB more sensitive to sounds originating from its front than the sounds originating from back. These microphones are useful, when speech signals are mixed with background noise. So, by using such hearing aids, a person can concentrate on the speech signals, he wants to hear, especially in noisy situations.

Omni or non-directional - These microphones pick up sounds from all directions. But, the problem with such microphones is that, it picks up unwanted signals also, as background noise. Hence, the speech signal reaching listener's ears becomes unclear.

Basically, the microphones used in a hearing aid are -

1. Carbon
2. Magnetic
3. Ceramic or piezoelectric
4. Electret

These types are depending on the materials used inside the microphones and principles of their operation. A particular microphone is selected according to the type of hearing aid and requirements of the hearing aid. An ideal microphone should have a flat frequency response over a large range of frequencies.

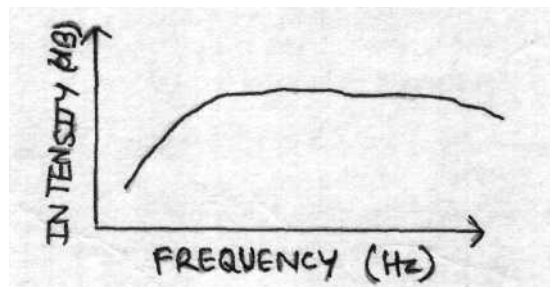

1) **Carbon microphones**: Earlier, carbon microphones were used in hearing aids. Such microphones do not have flat frequency response. They give rise to peak at a certain frequency.

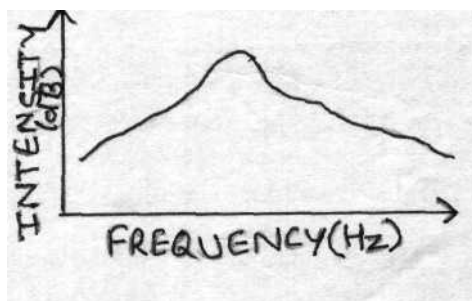



Sometimes, if multiple microphones are used, it results in giving different peaks, which is not an ideal condition.

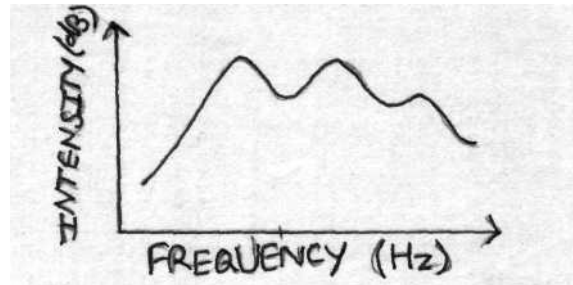

They also have limited frequency response, i.e. they can amplify sounds between 100 Hz to 4000 Hz range.

They do not give appropriate replica of the input. So, now-a-days, they are not used in hearing aids.

**2. Magnetic** - They have a rather ideal frequency response over the range of frequencies most important for speech i.e. mid frequencies (frequencies around 1000 Hz). Very high and low frequencies are not amplified. So, it is also not in use and not ideal.

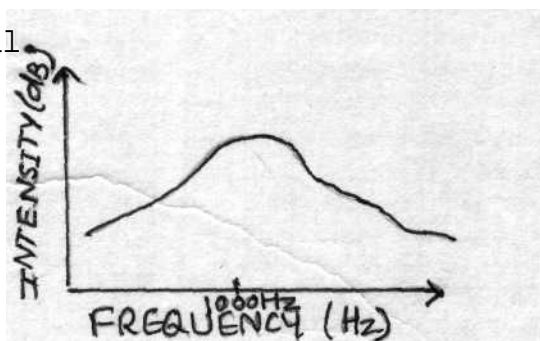

**3. Ceramic or Piezoelectric** - They respond equally to sounds over a wide frequency spectrum i.e. upto 20,000 Hz. They

also permit amplification of extremely low frequency sounds reaching a hearing aid. But, they are sensitive to shocks and drops.

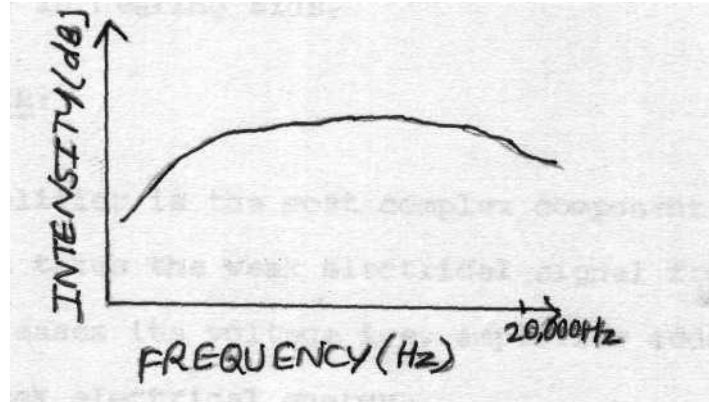

4. **Electret microphones** - They are the most commonest microphones used in hearing aids. They have a wide and flat frequency response across a wide frequency range i.e. upto 20,000 Hz. They are less subject to shock than ceramic microphones.

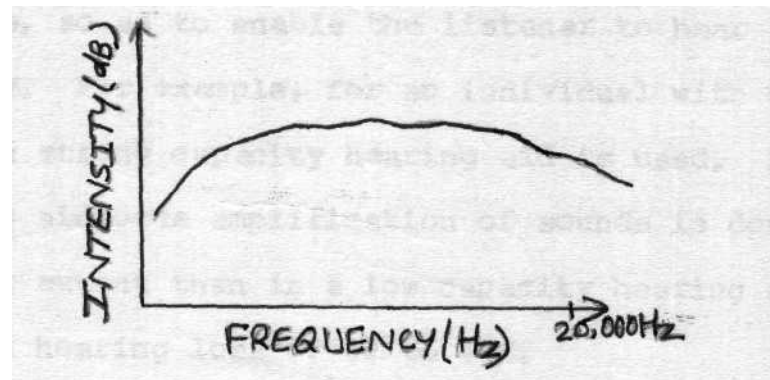

Electret microphones have replaced the magnetic and the ceramic microphones in most of the hearing aids. The electret /directional microphones are commonly used.

Out of four types of microphones i.e. Carbon, Magnetic, Ceramic and Electret; Electret microphones are used more commonly in hearing aids.

**AMPLIFIER:**

Amplifier is the most complex component of a hearing aid. It takes the weak electrical signal from the microphone and increases its voltage i.e. amplifier adds extra energy to the/weak electrical energy.

It consists of many small components which work together in amplification of sounds. The amount of amplification depends on the requirements of the hearing aid. In case of strong hearing aids, the amplification of electrical energy is more, so as to enable the listener to hear speech sounds clearly. For example, for an individual with 80-90% hearing loss, a strong capacity hearing aid is used. In such a hearing aid, the amplification of sounds is done to a greater extent than in a low capacity hearing aid which is used in hearing loss of 30 to 40%.

There are two types of amplifiers: Class-A which is used in low and moderate category hearing aids. Class-B/pushpull. which is used in strong category hearing aids.

Hearing aid amplifiers operate on two principles or in two ways.

- a) Linear - Here, as the input signal level increases, there is an equivalent (linear) increase in the output signal level.
- b) Non-linear - They are also called as 'output limiting amplifiers'. They have automatic volume control. They are used in patients who cannot tolerate very loud sounds. Here, output of the hearing aid is cut down, when the patients level of discomfort is reached.

Thus, the weak signal from microphone is amplified to a particular level, as beyond it the patient experiences pain or discomfort.

Depending upon the patient's requirements either the class-A or class-B amplifiers are chosen. They may be providing either linear or non-linear function.

### **RECEIVER:**

A hearing aid receiver is an important and delicate part of the hearing aid system. The hearing aid receiver is a small speaker, which converts the amplified electrical signal to the sound signal and feeds this sound energy to the ear.

A speaker:

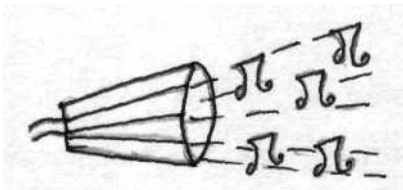

A hearing aid system:

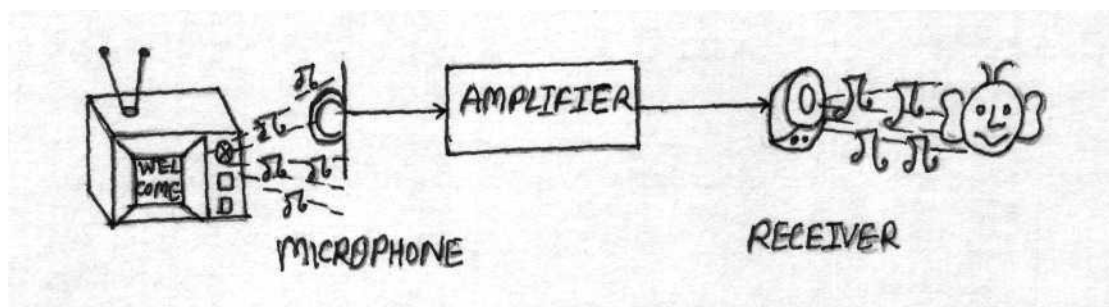

Types of receivers:

Basically, there are two types of receivers:

- 1) The air conduction receivers
- 2) The bone conduction receivers.

**1. The air conduction type receivers:-** These are the types

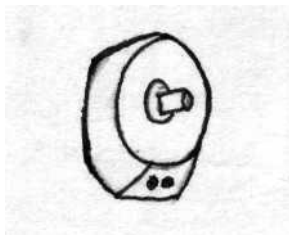

of receivers that are connected to the earmold and then placed in the external ear.

**2. The bone conduction type receivers:** These are the types

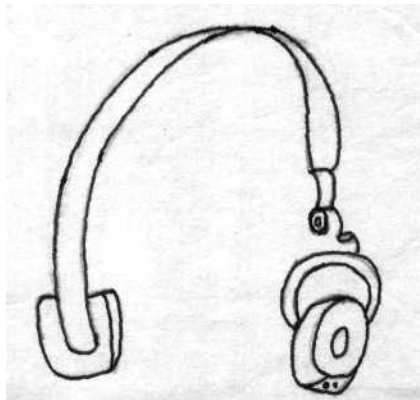

of receivers that are placed on a bone (the mastoid bone) behind the ear as in case of behind the ear and eye glass hearing aids.

The air conduction receivers can again be classified as -

- a) External receivers: These type of receivers are used in the pocket type hearing aids which are worn on the body by the user.
- b) Internal receivers: These type of receivers are used in behind-the-ear hearing aids. They are also used in eye glass hearing aids that are used in those individuals with both visual as well as hearing impairment. These receivers cannot be seen outside as they are placed inside the hearing aid case.

**How to achieve proper functioning of the receiver:**

The maximum benefit from the hearing aid can be obtained by using the type of receiver that matches the hearing aid system, that is, there should be impedance matching between the two systems, the receiver and amplifier of the hearing aid.)

**What is 'Impedance Matching' ?**

In all electrical and electronic circuits\* it is necessary that the input and output impedances should be equal or atleast in approximation.

For example - The output impedance of microphone should be equal to the amplifier input and output impedance of the amplifier should be equal to the receiver input.

The term impedance means, resistance due to self induction) to current in a circuit, i.e. it is the obstruction to the flow of sound energy/electrical energy.

In hearing aids, the impedance of the amplifier should match the impedance of the receiver for smooth flow of energy. If this condition, is not satisfied then there would be impedance mismatch between the circuits of two devices, which results in -

- 1) Loss of signal
- 2) Distortion of signal.

For example:- Impedance of the amplifier = X

Impedance of the receiver = Y

- a) Impedance matching --  $X = Y \rightarrow$  Smooth flow of output
- b) Impedance mismatch:
  - i) X is higher: The output of amplifier would be less, ultimately energy reaching the receiver would be less, so less output from the receiver.
  - ii) Y is higher: Though amplifier is allowing smooth flow of energy, as impedance of receiver is high, the output will decrease.

So, in a hearing aid, for the most effective output of sound signal, there should be impedance matching between the components of a hearing aid.

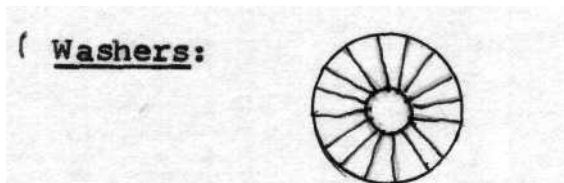

The washer is a small perforated disk of metal, rubber or plastic used to tighten the joints.

Plastic washers are used to tighten the joints between the receivers and earmolds, to prevent leakage of sound energy reaching the ear.

#### **Plastic and metal rings:**

The earmolds have a hole at the base, to which the receiver is fixed. This hole is bounded by a ring which can be made of plastic or metal materials. Selection of the ring depends on the case's requirements.

Plastic rings which are lighter, are comfortable. But they are less durable and ring fixing is cumbersome. The earmold should have larger hole for fixing plastic ring, so if the base of the mold is smaller as in case of children, then this ring cannot be used.



Also, in those people, who stay at far off distances and cannot visit the clinic very often, plastic rings cannot be used because of their shorter durability.

Metal rings last longer and fixing of these rings is not much cumbersome. So, they can be used in children and patients who stay at a distance from the place as they have longer durability.

### **Summary:**

Hearing aid receivers convert amplified electrical energy to sound energy. They are of two types:

- 1) Air conduction
- 2) Bone conduction

Air conduction receivers can be external or internal.

Hearing aid receivers should have proper washer on their surface to prevent leakage of sound energy reaching the ear because of the loose connection between the receiver and the earmold.

### **Points to be considered in purchase of receivers:**

1. Which type of receiver to buy i.e. air conduction and bone conduction receiver.
2. The user should purchase a receiver prescribed by the audiologist i.e. always a matching receiver should be purchased.

3. Washer on the receiver should be intact, to avoid leakage of sound energy.

### CELL:

Equipments as radio, tape recorders, clocks, work on battery. In the same way, hearing aid also functions on battery. But, as the type of hearing aid varies, the type and size of battery, also varies. That is why, every hearing aid user should know the type of battery to be used with his hearing aid.

A battery provides power for the working of a hearing aid. It helps in amplifying the sound energy that is picked up by the microphone of a hearing aid. Hence, the battery is a vital part of the hearing aid, without it, the hearing aid cannot function.

A battery contains many cells or units which are connected together.

Functioning: A cell is a cup or a vessel which contains,

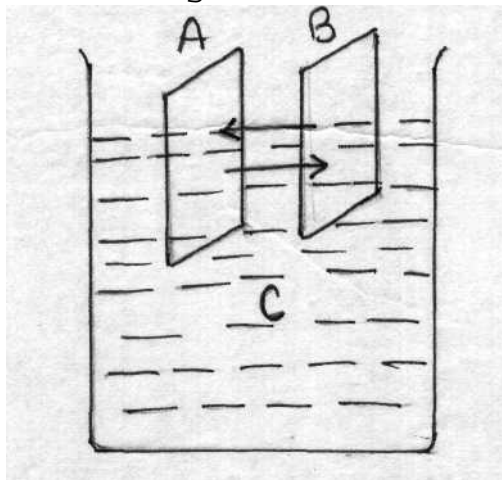

chemical solution inside it, with two metal plates dipped in. All three together help in producing electric current, which supplies the necessary power for the functioning of the hearing aid.

Thus, a cell contains two metal plates, A and B, and a chemical solution C. One plate A has negative (-) charge and other plate B has positive (+) charge. The liquid C allows current flow from A to B and B to A, thus working of the cell starts.

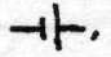
A symbol for the cell is represented by two lines together as , the short line indicates negative plate and the long one represents positive plate.

A group of cells connected together forms a battery; a series of short and long lines is used in a diagramm i.e.

 which represents a battery.

Most of the hearing aids use a single cell and so, really speaking, a hearing aid works on a cell and not on a battery.

**Types of cells:** There are mainly three types of cells used in hearing aids. The classification depends on the metal plate and liquid present in the cell for production of electric current.

- 1) Mercury cell
- 2) Silver-oxide cell
- 3) Zinc-air cell.

Mercury cell - There is a sudden drop of voltage in this type of cell and has shorter life i.e. lasts for shorter time, but more than silver-oxide cell.

Silver-oxide:cell: Life is shorter than mercury cell, also sudden voltage drop is seen.

Zinc air cell: When the cell is discharged, the output voltage drops gradually and at a significantly slower rate. It has longer life as compared to a mercury or a silver-oxide cell.)

This voltage drop and the life of each cell can be shown graphically as below:

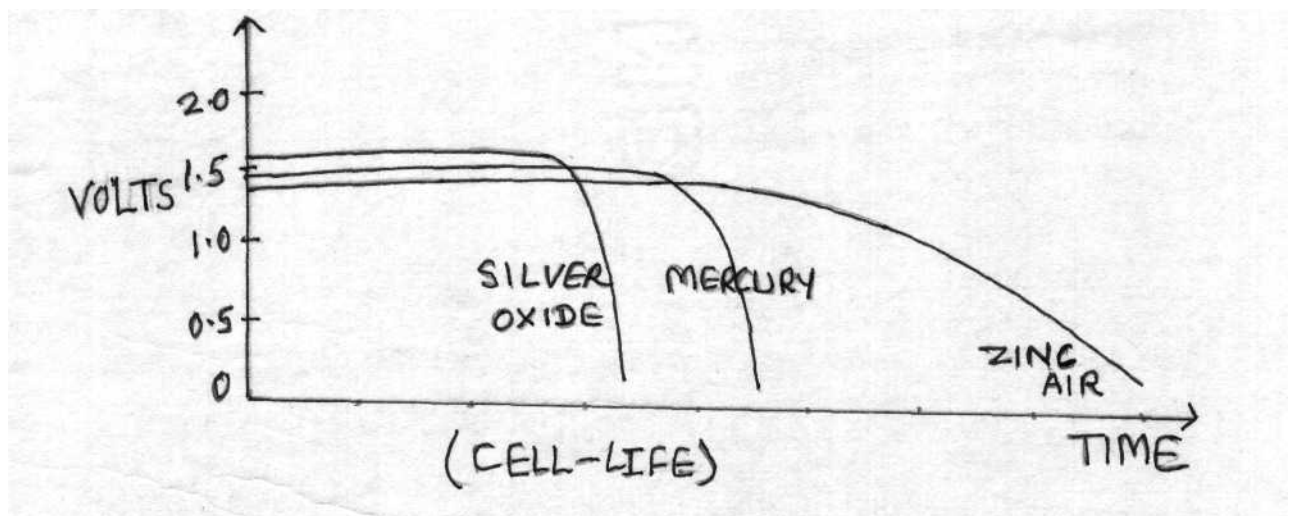

So, zinc-air cell is used commonly in almost all the hearing aids.

**Size:** Hearing aid cells come in various sizes. For body worn hearing aids, cells used are similar in shape. They are the cells, used in smaller flash lights and are called as 'Pentarch cells', commonly they are also known as 'pencil cells'.

But for a hearing aid worn behind the ear or in the ear or spectacle type hearing aid, much smaller cells are used, which are flat and round like a button, so are known as 'Button cells'.

So, every hearing aid user must remember that he should use the appropriate type of cell for his hearing aid, to get the best from his hearing aid.

**Voltage:** Most of the hearing aids which work on such single cell, either pentarch or button cells have voltage of 1.5 volts. So, every hearing aid user should see that, a cell provides the necessary voltage required for functioning of a hearing aid. A hearing aid fails to function, as the cell voltage drops below a certain voltage level. Cell voltage decreases, as the hearing aid is put to use. When the cell voltage goes below 1.2 volts, the cell has to be replaced.

Voltage is defined with the formula -

$$\text{Voltage (V)} = \text{Current (I)} \times \text{Resistance (R)}$$

$$\text{So, Current (I)} = \frac{\text{Voltage (V)}}{\text{Resistance (R)}}$$

i) So, as voltage decreases, resistance remaining the same current flowing through the circuit also decreases.

ii) As voltage increases, resistance remaining the same, flow of current also increases.

**For example :**

1. Case : say  $V=1$  and  $R=5$

2. Case say  $V=5$  and  $R=1$

$$I=V/R \quad I = V/R$$

$$\begin{aligned} I &= 1/5 & I &= 5/1 \\ I &= 0.2 \end{aligned}$$

$$I = 5$$

In a hearing aid also, as the voltage keeps dropping, the current flowing through the circuit decreases. Hence as the cell voltage drops, the cell has to be replaced. If not, the hearing aid cannot function.

### **Cell life:**

How long a cell lasts, depends upon the power requirements of a hearing aid. In a strong hearing aid, the cell life will be less than a moderate hearing aid i.e. the cell life depends upon the efficiency of the microphone, the amplifier and the receiver of the hearing aid and also on the volume control setting. As the energy requirements of a hearing aid, increase, per unit of time period for which cell works, decreases.

### **Process of recharging:**

Some of the cells are rechargeable. Once the cell voltage drops, by applying an electric energy, the cell

can provide the requisite current again. A car battery is a simple example of this charging and recharging process. Thus, the process of recharging can be repeated. A single cell can be recharged 500 times, after which the cell has to be replaced.

In practice, the process of recharging is not so economical in case of body level hearing aid which uses a pentarch cell as -

- 1) A pentarch cell costs less and at the most two or three cells may be needed in a month, for a regular hearing aid user.
- 2) The recharger instrument of a body worn hearing aid is bulky. The process of recharging takes about ten to twelve hours. The user has to always carry one spare cell with him, which he can use when the other cell is being recharged. Thus, the process of recharging is time consuming. So, it can be advised to buy a fresh cell, instead of recharging the old cell. Using a fresh cell is more economical, as the cost of a cell in such a hearing aid is also less.

Purchase of rechargeable cells for the ear level hearing aid which uses a button cell may be indicated for the following reasons:

1. A button cell costs around Rs.15-Rs.20.
2. The recharger instrument is very small and can be carried inside the pocket also.
3. For a regular hearing aid user, it can be economical, as the user does not have to spend more money on the cell, though the process is still time consuming.

So, depending upon whether the user can afford to buy a recharger and is ready to spend some time for the process, a recharger is advised. Usually, special recharger cells are available with the dealers.

**Points to remember :**

1. Maximum cell life can be achieved with daily use and daily recharging.
2. Charging requirements should be met daily regardless of hours of use, it ensures that the cell is never completely discharged. A cell should at least be charged once in three days. if it is kept without recharging for more than three days, it gets discharged.
3. A cell should be charged for 8-12 hours.
4. Recharged cell lasts for approximately 12-18 hours depending on hearing aid type.
5. After full recharge, i.e. say after 500 times of recharging process, cell gives short life and so it must be replaced.



**Guidelines for the effective use of a hearing aid cell**

1. As said earlier, each cell has a positive (+) and negative (-) terminal. The cell compartment of a hearing aid also has (+ and -) marks. So, a hearing aid cell is to be placed, such as the (+) sign on the cell and that on the cell compartment (+) corresponds and (-) sign on a cell should correspond to (-) sign of the hearing aid cell compartment. If the cell is not kept in such a way, the hearing aid does not function.
2. Before replacing the cell in a hearing aid, the hearing aid should be switched off.
3. The cell should be removed from the hearing aid, if the aid is not being continuously used, otherwise hearing aid constantly consumes current from the cell. Hearing aid may also get damaged, if the cell starts leaking.
4. Before placing the cell inside the hearing aid, a plastic cover around it should be removed carefully.
5. A cell must be always kept in a cool and dry place. If it is kept in moisture, the terminals may get corroded.
6. If the cell terminals or contact surfaces get corroded, they can be cleaned with knife or blade, gently.
7. The user should always keep a spare cell with him.

He should also keep track of the average life of the cell he uses, after the hearing aid use has stabilized. It can be decided depending on for how many hours in a day he uses the hearing aid. This average serves as a figure to alert the user to the time, when the cell functioning may fail.

8. An old cell should be discarded carefully, because if it come in contact with fire, there is a possibility of explosion.

#### **Summary:**

The cell is an important part of the hearing aid. There are three types of cells as Mercury silver oxide and Zinc-air cells. Now-a-days, zinc-air cells are used more commonly in the hearing aids.

The user must buy a cell that is appropriate for his hearing aid, either a pentarch or a button cell.

#### **EARMOLD:**

An important part of the hearing aid is individually molded earpiece or insert. It is made of a material called 'Acrylic'.

The earmold physically attaches the hearing aid to the delicate parts of the ears and is designed to conduct the

amplified sound from the output receiver of the aid into the ear canal as efficiently as possible. It seals off the ear canal to help in eliminating the annoying squeal sound sometimes heard from a hearing aid which might interfere with speech perception and to fit the receiver efficiently in the ear.

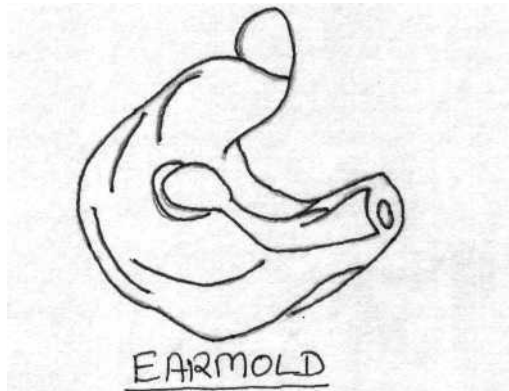

So, the earmold is more than just a sound channel, a good earmold will maintain the important balanced envelope of sound selected for the user and provide utmost comfort to the user.

If not coupled properly, it affects sound energy reaching the ear.

#### **Ways of making earmolds;**

- 1. Custom earmolds:-** They are made from the impression taken of the hearing aid user's ears, both right and left ear.
- 2. Standard earmolds:-** They come in various sizes and person can choose the appropriate earmold depending on his ear size.

It is better to have custom earmolds as they are exact copy of an impression of an individual person's ear, so they fit properly. Standard earmolds may not fit properly in the ear.

Another type of ear insert is provided by the hearing aid dealer which comes in the form of a ear-tip or a small plastic tube. But they don't fit properly in the ear and may fall off. So, it is always advised to use a custom earmold with the hearing aid. Facilities for making custom earmolds can be available at some of the speech and hearing centers.

#### **How to attach receiver to the earmold?**

The receiver is made with a small tube like projection at 'nub' on its face that snaps into a recess in the earpiece and is held there by a ring in the earmold. The sound passes through this nub and through a hole drilled in the earpiece and is delivered well down in the earcanal of the ear.

#### **Different earmold styles in use today are -**

There are different special types of earmolds that are used with different hearing aids, as -

- 1) Receiver mold - is used with both body level and ear level hearing aids with an external receiver.

- 2) Shell mold - is used for hearing aids with internal receivers, used with very high gain ear level hearing aids.
- 3) Skeleton mold - used with moderate gain ear level hearing aids.
- 4) Canal mold - used for moderate gain ear level hearing aids and has maximum cosmetic appeal.
- 5) Canal lock mold - used with moderate gain hearing aids and allows proper fitting of the earmold inside the ear.
- 6) All-in-the ear mold - designed to couple and hold in 'all in the ear hearing aid' in the ear.

According to the requirements of the user and type of hearing aid used, earmold is prescribed. But, it is always better to have custom ear mold, as it is the impression taken of the individual's ears.

Purchase of the ear mold:

- 1) Appropriate type of earmold should be purchased.
- 2) In case of custom earmolds, even in standard earmolds, it should fit properly in the ear.
- 3) Receiver should fit properly into the ear mold. So that the receiver does not revolve. If it does revolve, the ring of the ear mold should be got fixed properly.
- 4) Earmold should not be broken, even if one part is broken, it will not fit properly into the ear and may fall off.

**CORD:**

The cord is a thin wire that carries the amplified signals from the amplifier to the receiver, i.e. it connects the amplifier with the receiver.

As the ordinary electrical wire carries the electrical energy, the hearing aid cord also carries the electrical energy from the amplifier to the receiver. It is a very thin, flexible and delicate part of the hearing aid. At both ends of the cord, plug pins are attached to connect it with the hearing aid.

**Pins of the cord:**

Hearing aid cord has either two pins or three pins, like a regular plug pin. Of which one is shorter and the other one is longer.

**Types of cords:**

There are three types of cords as:

- 1) Single or 's' cord.
- 2) 'V' cord
- 3) 'Y' cord.

The use of the cords depends upon whether a single receiver or two receivers are used. With a single or 's' cord, one receiver is used. With 'V' or 'Y' cord, two receivers are used. 'S' and 'V' cords are used more commonly. 'Y' cord is used rarely.

Single cord is used in cases who need hearing aid in one ear only, while V- or Y- cord is used in cases who need hearing aid in both the ears.

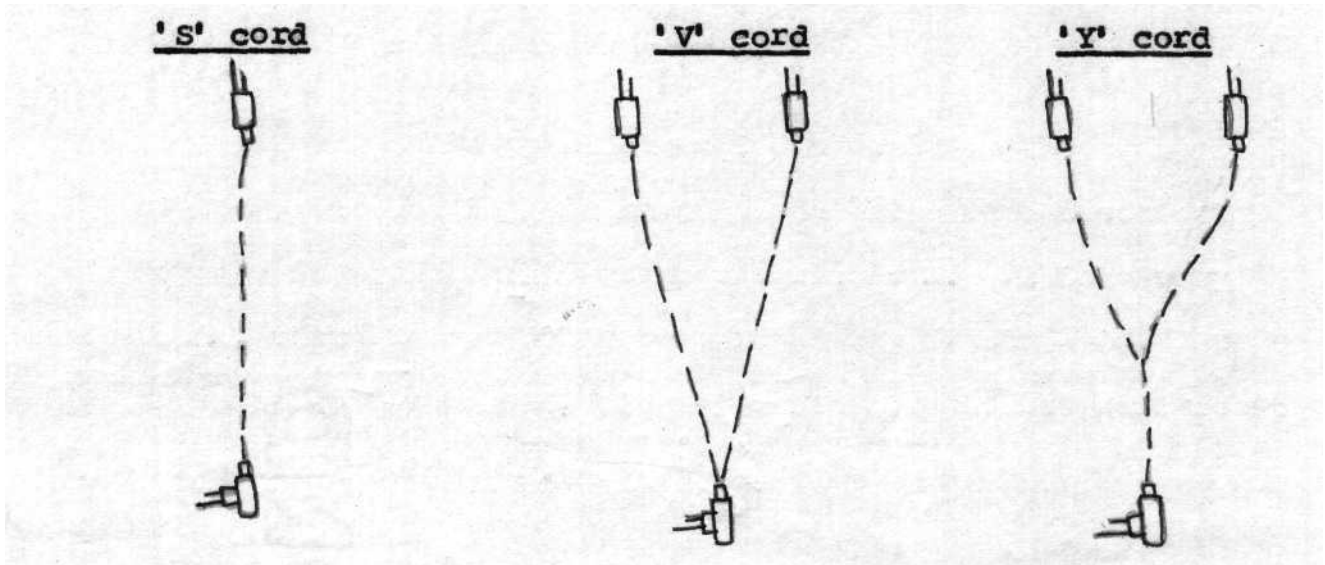

One end of the cord is connected to the body of hearing aid, called as 'angle flex' point. The other end is connected to the hearing aid receiver, called as 'odiflex' point.

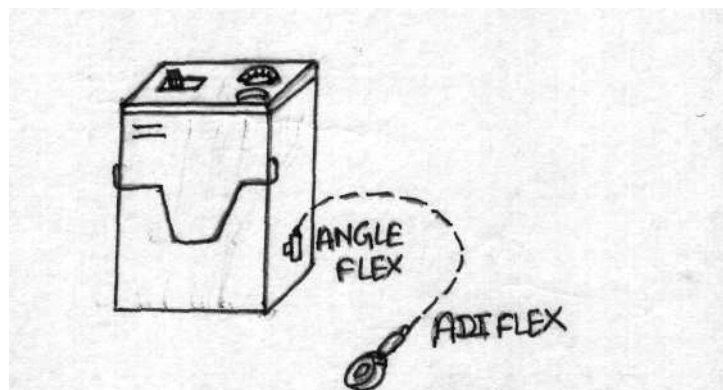

Length of the hearing aid cord is 50 cms.

Such a coxa is used in the hearing aids which are pocket type i.e. worn on the body of a person.

In some types of hearing aids worn behind the ear, instead of such long cords, plastic tubes are used for conduction of the sound energy.

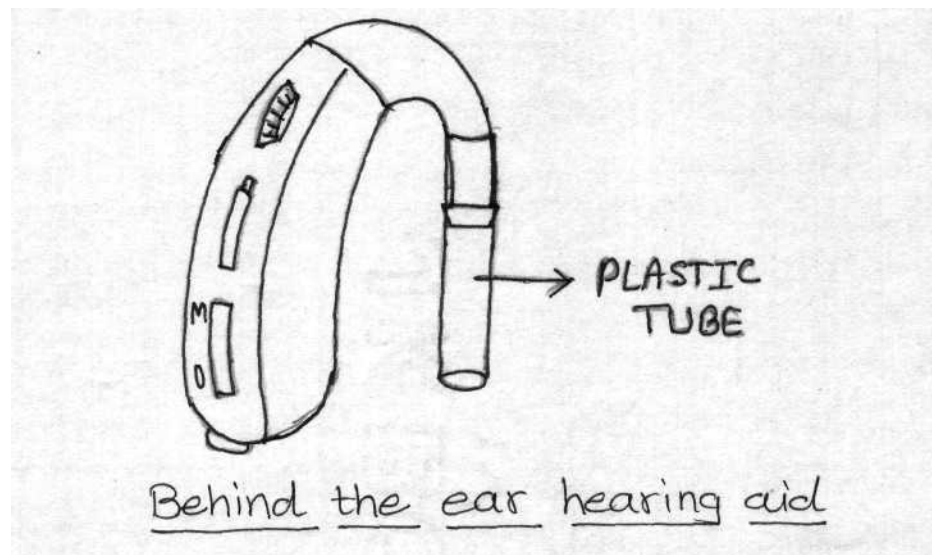

#### **Purchase of the hearing aid cord:**

Points to be noted -

- 1) Whether it is 's', 'V' or 'Y' cord as prescribed by the audiologist.
- 2) Whether it is 2 pin or 3 pin cord.
- 3) Cord should be checked carefully to detect any breaks along its length.
- 4) Length of the cord should be 50 cms.

#### **Care of the cord:**

- 1) As it is the most delicate part of the hearing aid, it should be used carefully.
- 2) The cord should always be kept straight, when the hearing aid is worn, as it allows smooth flow of sound energy.



- 3) The cord should not be knotted, twisted or coiled, as it causes breakage in the cord, resulting in intermittent flow of sound energy. Cord should not be twisted or pulled.
- 4) Plug pins of the cord should be cleaned periodically with a small brush.
- 5) The cord should not be detached from the hearing aid when you do not use the hearing aid. It does not harm the hearing aid function. Unnecessary detaching of the cord will result in breakage of the pins of the cord. You can just wind the cord gently on your palm and keep it along with the hearing aid into the box, to ensure the safety of the cord.
- 6) The cord should be fixed tightly to the hearing aid body or receiver. Pins should be replaced if they are broken. If the cord is broken and it is beyond repair, the cord should be replaced. Plastic tube should also be replaced, if it is beyond repair in case of ear level hearing aid.

#### **VOLUME CONTROL:**

It is similar to a volume control on a radio or a T.V. A hearing aid user needs to adjust the sound intensity he is receiving. He may for example need less intensity in a very noisy environment. The volume control helps to adjust the

amplification, however, it does not alter the input sound to the aid. It just helps to adjust the amount of amplification of the input signal i.e. gain of the hearing aid, most useful for the hearing aid user.

Most of the hearing aids have a dial or a knob that serves as a volume control. It has numbers marked on it, to indicate the level of the output of the hearing aid reaching the ears. Usually, the numbers range from 1 to 8 or 9, 1 - indicating minimum gain while 9 indicating maximum gain. But



Volume control numbering varies in different hearing aids. It may not be enough to indicate that the volume increases with number on the dial.

Relatively little gain is available once the volume

control is advanced beyond 50% of its total range. Most of the gain is delivered in the lower half of the control, while only a limited amount of gain is available in the last half. As user may receive some additional gain control beyond 50% setting, he may also encounter an unusually high increase in harmonic distortion that decreases the added gain, affecting understanding of speech.

#### **Care of the volume control:**

1. Volume control dial is also delicate, so it should be handled gently.
2. It should be kept on the position advised by the audiologist.
3. It should be cleaned regularly by a brush.

**Purchase of volume control:**

Points to be noted -

- 1) Smooth rotation of the volume control wheel should be there.
- 2) Numbers should be marked on the volume control wheel for easy adjustment of the volume control.

**ON-OFF SWITCH:**

Equipments like radio, T.V., tape recorders have on-off switch. In the same way, hearing aids also have on-off switch to make and break the circuit depending on the position it is placed. When the switch is on the 'ON' position, it allows the passage and amplification of the sound i.e. hearing aid functioning. When the switch is in the 'OFF' position, it breaks the circuit, thereby stopping the hearing aid functioning. Hearing aid should be switched off, if the hearing aid is not in use. Before switching on the hearing aid, volume control should be kept in the minimum position. It should be switched off, while changing spare parts of hearing aids as battery, cord, receiver or earmold.

**Purchase of on-off switch:**

- 1) Many of the hearing aids may not have a separate on-off switch. Volume control is used as a on-off switch, by setting the volume control to a minimum position in some of the hearing aids

Before purchase of a hearing aid, the user must check whether his hearing aid has a separate on-off switch or not. It is advised to have the on-off switch as a separate control.

- 2) Switch should be intact, any breakage would hamper hearing aid functioning.

## ACCESSORIES OF THE HEARING AID

### i) TONE CONTROL:

Tone control is one of the important switches of the hearing aid. Tone control changes the gain at the various frequencies amplified by the hearing aid i.e. it changes the frequency response of the instrument.

Tone control is generally thought of as a circuit designed to provide high or low frequency emphasis, such as treble and bass adjustments on a stereo.

The circuit essentially does this, but by frequency suppression or filtering, rather than by emphasis or additional gain.

#### Internal structure:

For high frequency emphasis, a high-pass filter network is used i.e. low frequencies are filtered and high-frequencies are allowed to pass. For low frequency emphasis, a low pass filter network is used i.e. high frequencies are filtered and low frequencies are allowed to pass.

The tone control offers three options to the user. By making use of one of the options, the user can be helped in hearing sounds.

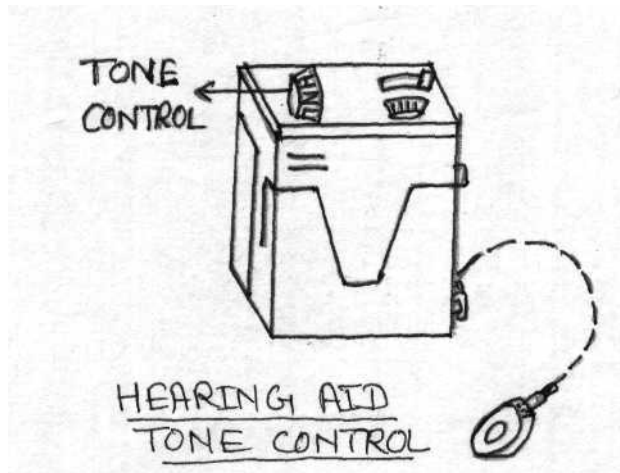

The tone control is marked H, L, N. 'H' being high frequency emphasis, 'L' being low frequency emphasis, 'N' Normal i.e. no special emphasis on the high or low frequencies.

**Function:**

Thus, if the user needs more of high frequency emphasis, he may/be advised to turn the tone control to a position marked 'H'. For low frequency emphasis, tone control may be adjusted to 'L', otherwise to 'N'. The tone control should be set to the position prescribed by an audiologist for best performance.

Tone controls can be located on the outside or inside the case, as a switch or screw adjustment.

Some hearing aid manufacturers produce instruments with no adjustable tone control. When the hearing aid is ordered, the response desired is specified and appropriate circuitry is installed at the factory.

Thus, tone controls can be external or internal. External controls can be manipulated by the user. Internal controls

are adjusted by the manufacturer or dealer, before he sells the instrument, to satisfy the purchaser's individual requirements.

Tone control switch is very delicate, so it has to be turned carefully and gently, it should be handled only if necessary, it can be adjusted to H,L,N depending on user's requirements.

**ii) TELECOIL:**

Hearing aids with telephone pick-up coil or telecoil are an advantage because they allow the wearer to use the telephone without the interference from background noise.

**Switch:**

Hearing aids with this component have either a two or three position switch that allows use of the microphone alone, i.e. 'M', the telecoil alone 'T', or both together 'MT'. If the switch is adjusted to 'T' position, the microphone i.e. 'M' is cut off. 'MT' means the user can listen to the telephone and also the background speech i.e. normal conversation can be used simultaneously.

When the switch is adjusted to 'T' position, the telephone receiver should be held against the case of his hearing aid and not on the ear of the user.

Thus telecoil is a very useful option for those hearing-impaired who are frequent telephone users.

**Use:**

Every user must learn about telecoil manipulation and switch position. Otherwise, the switch may be inadvertently moved to the telecoil position, in which case the hearing aid, in general use, will deliver no useful signals.

**Purchase of telecoil:**

1. Prior to purchase of his hearing aid, every hearing aid user should mention whether he needs telecoil facility or not.
2. He should also check the functioning of the telecoil prior to purchase.



## DECIBEL

Most of the quantities are measured in fixed units as feet, meter, kilogram etc. For example, when we say that the distance between two points is 20 meters, we mean that the distance between the points is 20 times greater than one meter. For measuring sound intensity we use a unit, watts/cm<sup>2</sup> .

But, it is convenient to measure sound intensity along the 'decibel scale'. It is most often denoted as 'dB'.

Decibel is a very important term for a hearing aid user, as the amount of hearing loss he has, is expressed in decibels. Also the gain of a hearing aid is expressed in decibels. How powerful a hearing aid is, is also measured in decibels. Thus, decibel is an important concept to become familiar with.

Decibel is not an absolute or fixed unit such as grams, meter, feet. But still, it is convenient to use. It is expressed in logarithmic scale. It refers to a logarithmic ratio between two quantities. It is a ratio between two quantities, a measured quantity and a quantity used as a reference. The quantity used as a reference is predetermined. For example, if the measured quantity is 25 and the reference point is also 25, the ratio will be 1:1 ( $25/25 = 1/1$ ).

Thus, in case of hearing aids, the dB gain is the ratio between a measured quantity i.e. the output of a hearing aid (level of sound that is coming out of the hearing aid) and the reference point i.e. the input to the hearing aid (level of the sound that is entering the hearing aid). This calculation helps one to know the amplification capabilities of a hearing aid.

The word decibel can be divided into two parts: deci and bel. 'Deci' meaning 10 and 'Bel' is in honor of Alexander Graham Bell, the inventor of the telephone. The decibel is one-tenth of a Bel i.e. 1 Bel = 10 decibels. Since, 'Bel' is large quantity to work with, a decibel is normally used.

Decibel helps us to know the approximate level of a sound that will be heard by the listener i.e. it gives an idea about loudness of sound that will be perceived by that person.

The easiest way of expressing a ratio between two numbers is to use logarithmic scale, as it reduces a large range to a smaller one and a bigger number is reduced to a smaller one. The strongest sound which we can hear without feeling pain is as much as 10 million-million times greater in intensity than a just audible sound. This huge intensity ratio corresponds to 130 dB in decibel scale, which is much more convenient figure, thus the dB scale has greater convenience than using the actual numbers.

Usually, a sound intensity in dB is expressed to relative intensity of  $10^{-16}$  watts/cm<sup>2</sup> (which is near the level of a just audible sound). For example, if the intensity of sound is 60 dB in decibel scale, it is relative to sound of  $10^{-16}$  watts/cm<sup>2</sup>, which is the level of a just audible sound.

There are different kinds of decibels. One is 'dB Sound pressure Level' i.e. dB SPL. It is the scale used by engineers, but it is also important for audiologists. It is the most convenient measure as it is easier to measure the pressure of a sound signal than its intensity. Thus, first the sound pressure is measured from which sound intensity is calculated. Sound intensity is proportional to square of sound pressure i.e. if the sound pressure measured is 10 dB, the sound intensity will be 100 dB, which is square of 10.

Second scale is 'dB Hearing Threshold Level' i.e. dB HTL, used in measuring human hearing, it is a measured quantity. Here, the reference point is the amount of sound pressure that can be heard by a group of young, normal hearing persons. Thus, the dB HTL scale is used to test the hearing of a subject by means of an audiometer.

Other scale is 'dB Sensation Level' i.e. dB SL, which is the number of decibels a sound is above the hearing threshold of a given individual. For example, if a person can barely hear a sound at 0 dB HTL, which is his hearing threshold, a sound given to him at 30 dB HTL, would be 30 dB above his threshold i.e. 30 dB Sensation Level, so, in order to know dB SL, which is a measured quantity, the threshold of the individual at a given frequency (i.e. the reference point) must be known. Here, hearing threshold means the level at which the sound is so soft, that it can be heard only 50% of the time it is presented i.e. if the sound is presented four times to an individual, he should be able to hear that sound at least 2 times, then the level of sound becomes hearing threshold of that person.

Thus, the letter 'dB' must be accompanied by other letters such as 'SPL, HTL, SL, IL, so as to know which quantity is being referred to. In all these cases, the reference quantity is identified and the user of the expression, understands the reference quantity used. Thus, for dB SPL, the reference is 20  $\mu$ dPa; for dB HTL, the reference is the audiometric zero; for dB SL, the reference is the person's own hearing threshold at a frequency of interest.

ELECTRO-ACOUSTIC CHARACTERISTICS OF HEARING AID

Electroacoustic characteristics help in knowing the input-output performance of the hearing aid, and depending on these performance characteristics a particular hearing aid is prescribed. These characteristics are as follows:

**GAIN:**

Gain is an important characteristic of a hearing aid, that the user must know about.

Gain is defined as the increase in the signal power that is produced by an amplifier usually given as the ratio of output to input voltage, expressed in decibels.

Gain is measured by determining the difference in decibel between the level of the input at the microphone and the level of the output at the receiver. For example, if input =  $x$  and the output =  $y$ , then gain =  $Y / X$  (o/P i.e i/p).

Gain is the term used to describe an increase in loudness of a signal as in hearing aids. Gain of the hearing aid is the amount of amplification, it provides. Thus, it gives an idea as to how much of a boost, a hearing

aid can give to sounds. The unit of gain is decible (dB). Gain of a hearing aid is expressed in numbers as 30 dB, 45 dB etc. A higher number indicating higher gain.

Depending on their gain, hearing aids can be classified into different categories, as mild, moderate and strong gain hearing aids. This classification has been derived on the basis of hearing impairment levels in the audiometer i.e. for selecting a hearing aid that has a gain equal to the hearing level established by the audiometric tests.

The gain of a hearing aid is adjustable with the help of a volume control. As the volume control is increased, the amount of gain also increases. But once the volume control is rotated beyond 50% of the total range, the amount of total gain decreases and the distortion increases.

Determination of the amount of gain required by a hearing impaired individual is based upon 'most comfortable level' of a patient i.e. it is the level at which the patient does not have to put extra effort in listening and sounds are amplified appropriately to fulfill the user's requirements. The sounds are not too soft or not too loud.

The signal sent through a hearing aid for calculating the gain, is a series of puretones of varying frequencies, but all being at the same intensity level.

### Types of gain:

Gain of a hearing aid can be measured in different ways. They are taken into consideration by a hearing aid manufacturer in the process of manufacturing the hearing aids. They are -

- 1) Peak gain
- 2) Average gain
- 3) High frequency average gain.

1) Peak gain:- It refers to the maximum gain of a hearing aid. It is the point on the gain curve at which the gain is maximum. It is important to know the dB level of the peak gain and also the frequency at which it occurs. Example -

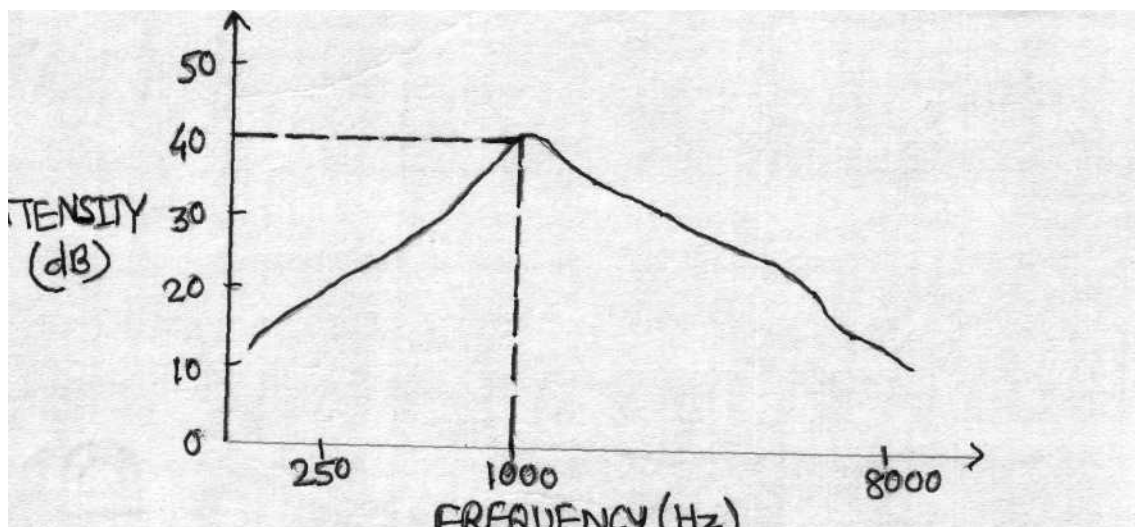

Peak gain = 40 dB at frequency of 1000 Hz.

It is important because the user's comfort setting of a

hearing aid with a peak gain of 40 dB, but the aid used has a peak gain of 50 dB. In this case the gain setting of the user's hearing aid will be reduced because of the peak, which might result in insufficient amplification for the patient.

The user should find out this peak gain of his hearing aid and the frequency at which it was obtained.

2) **Average gain**:- It refers to the average value of the gain at three frequencies. The average gain is measured at 500 Hz, 1000 Hz and 2000 Hz. Example-

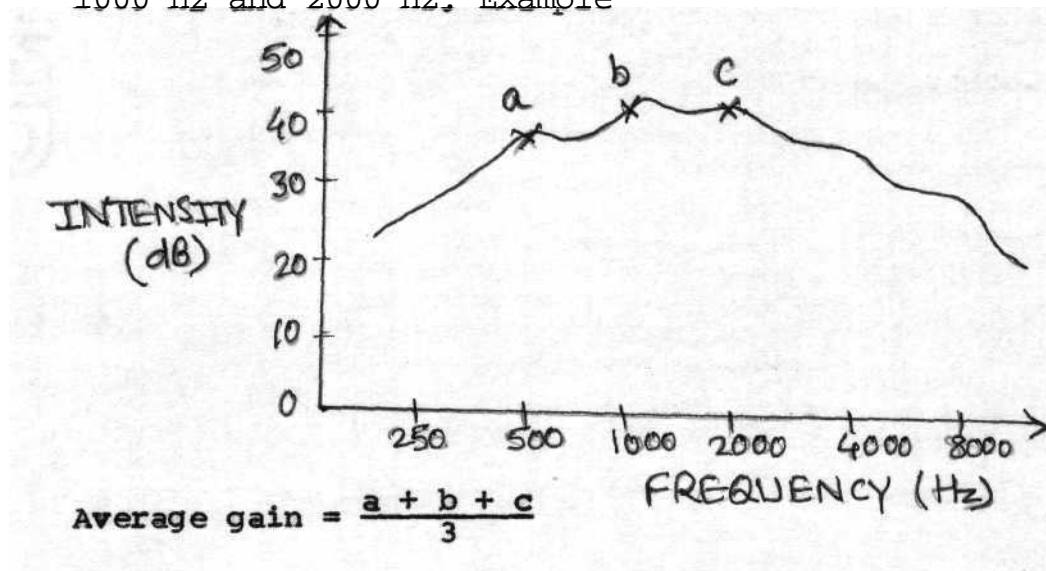

3) **High frequency average gain or HF average gain**:- HF average gain refers to the average value of the gain at three higher frequencies i.e. 1000 Hz, 1600 Hz and 2500 Hz. Example -



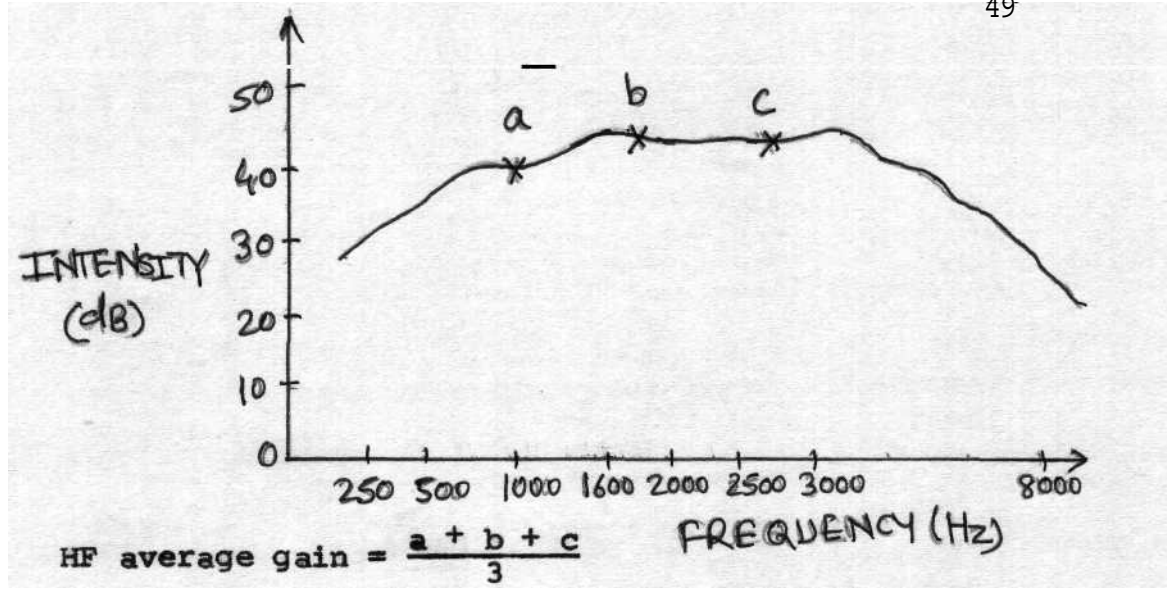

There are three more parameters, that are used by a clinician in prescription of a hearing aid in collaboration with the three previous parameters: They are -

- 1) Functional gain
- 2) Insertion gain
- 3) In-situ gain

1) **Functional gain** - Functional gain is the difference between the unaided and the aided responses of the hearing aid user at the audiometric frequencies (i.e. from 250 Hz to 8000 Hz).

Here, unaided meaning the responses of the user without the hearing aid and aided are the responses of the user when he is wearing a hearing aid.

Functional gain is measured behaviourally. It is a subjective method of measurement as the responses depend upon the user.

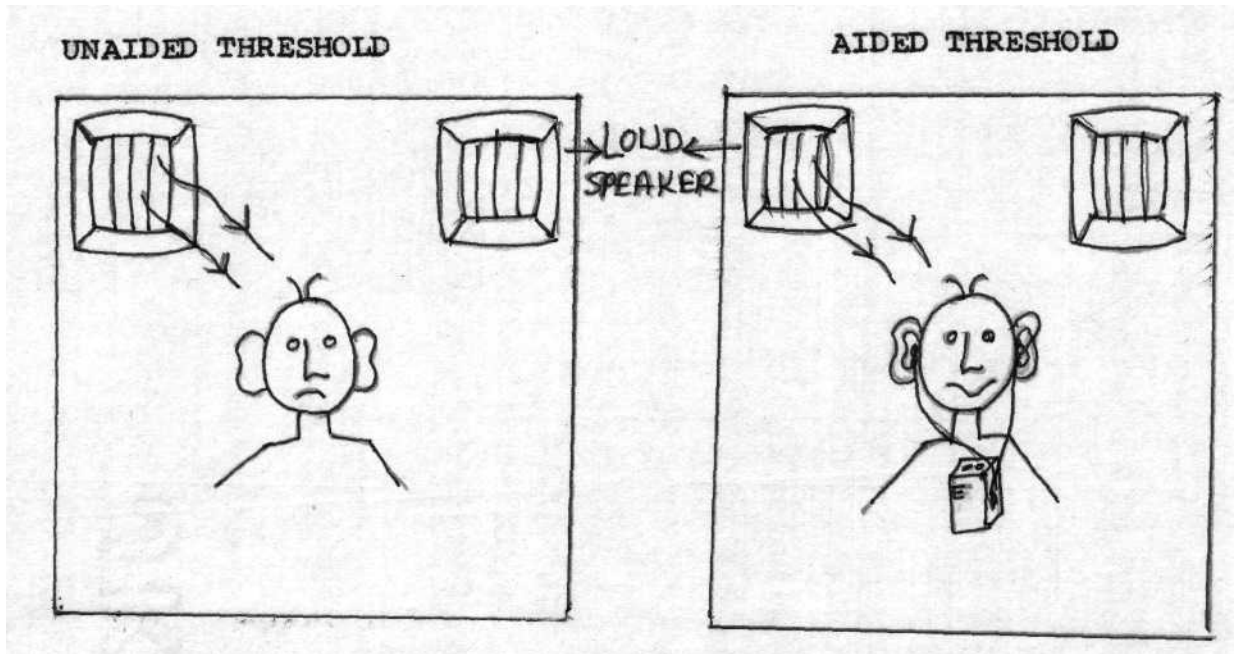

2) **Insertion gain** - It is the difference between the sound pressure level measured near the eardrum, with and without a hearing aid.

It is measured electroacoustically, i.e. it is an objective method of measurement of gain, where the user does not have to indicate the response, they are recorded with the help of an instrument.

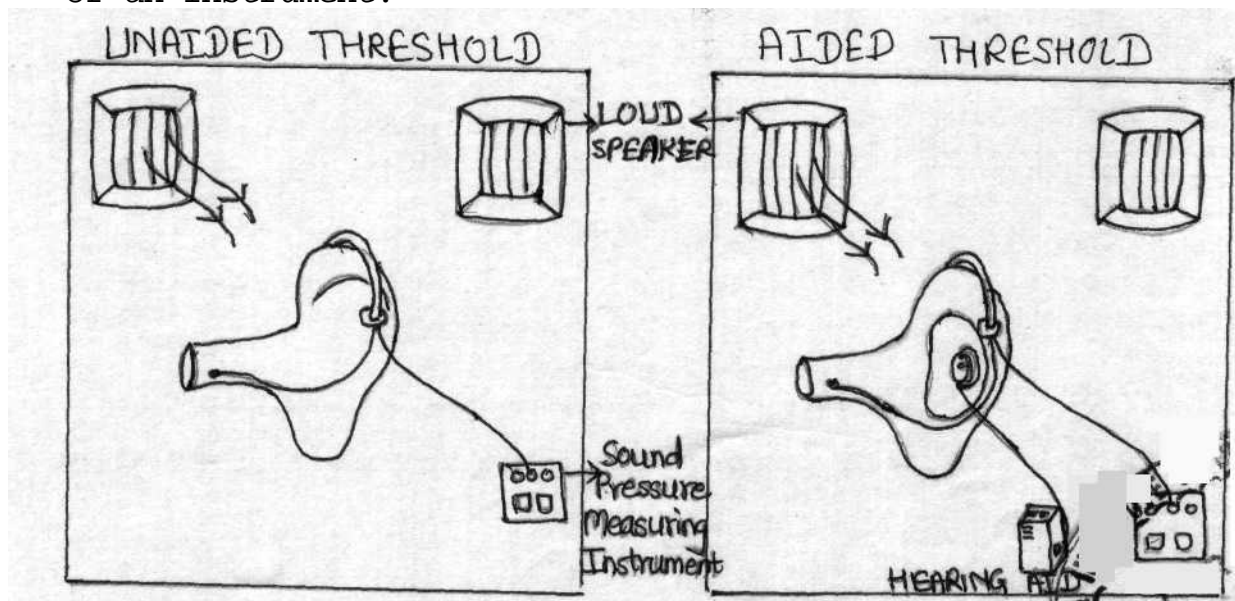

**3) In-situ gain** - It is the difference between the sound pressure levels at the eardrum of the subject using a hearing aid and a free-field sound pressure level at the position of the subject, when the subject is not present.

It is measured electroacoustically, i.e. it is an objective method of measurement.

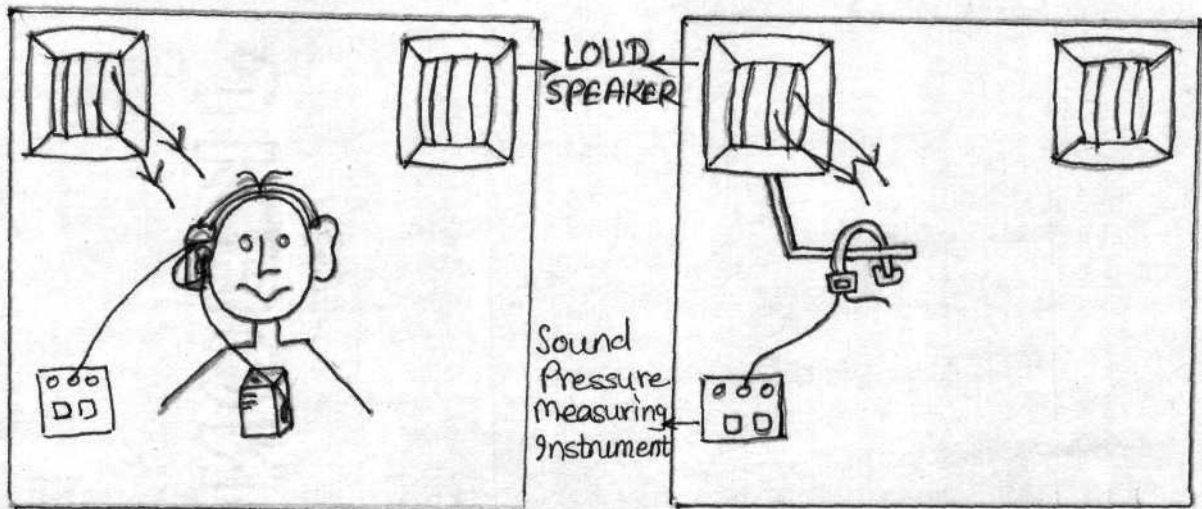

Gain of a hearing aid varies across frequencies depending on the characteristics of individual hearing aids. It differs depending on the parts used in construction of a hearing aid, so the gain at some frequencies may be more than others i.e. the hearing aid may boost certain frequencies to a greater extent. A hearing aid can be designed to give more gain at higher frequencies and less at lower frequencies or vice versa, depending on the user's requirements.

#### **Automatic gain control hearing aids:-**

In some hearing aids, a special circuit may be added, to automatically reduce the gain when sound crosses the present limit of the hearing aid.

This is done so that the sound level reaching the hearing aid user does not cause pain to the user. Such kind of circuits are used in some special hearing aids as 'automatic gain control hearing aids', which are given to people who cannot tolerate very loud sounds i.e. even if the sound reaching the microphone of a hearing aid (Input) is very loud, the output is automatically controlled to reduce the gain of the hearing aid, so that it does not cause discomfort to the user.

Based on gain, different hearing aids can be categorized as Mild (31 - 52 dB), Moderate (41 - 62 dB) and those Strong (58 dB and above).

Gain characteristics are considered in terms of the client's hearing loss and the amount of amplification needed to compensate for that hearing loss i.e. a person with a mild hearing loss would not be a candidate for a hearing aid in the strong category as it would be too powerful for him. At the other extreme, a mild gain hearing aid would not be selected for the individual with a severe hearing loss, as the hearing aid would not be able to provide sufficient amplification to compensate for the loss.

Body worn hearing aids are designed to help individuals with mild, moderate and severe impairment, as they come in all three categories i.e. mild, moderate and strong gain hearing aids.

Behind the ear hearing aid are designed to help most individuals with mild to moderate hearing impairment, the gain of the hearing aid being upto 65 dB.

In-the-ear hearing aids can provide the gain values upto 45 dB i.e. can be used to help the individuals with mild hearing impairment.

Another type of hearing aids is Eyeglass hearing aids, where hearing aid circuit is mounted inside the rim of the spectacles. It can be used in those individuals who have a dual impairment i.e. visual and hearing. Gain of such hearing aids is upto 65 dB, it can be used with the persons having mild to moderate hearing impairments.

**Summary:**

Thus, in manufacturing of hearing aids, 3 types of gains are involved as

- peak gain
- average gain
- high frequency average gain.

A clinician makes use of three more types of gain in addition to the above three, for prescribing a particular hearing aid. These are -

- functional gain
- insertion gain
- in-situ gain.

Hearing aids can be categorized as mild, moderate and strong gain hearing aids depending on their output characteristics.

#### **FREQUENCY RESPONSE:**

Sounds of various frequencies reach the hearing aid microphone. These sounds can be of low frequencies i.e. low pitched or high frequencies i.e. high pitched or those which fall in between these two, they are mid-frequency sounds. The hearing aid may not amplify all the sounds to the same extent, it shows preference for some frequencies by making them louder, while other sounds are not made louder to the same extent. Depending on the nature of the components of a hearing aid, some frequencies of sound signal are amplified more efficiently than others. This relation between the frequency and amplification gives the frequency response. It is a graph of acoustic output of a hearing aid against the frequency of the input signal. This graph depicts, for each frequency, the amount by which the instrument

amplifies the incoming signal. In this frequency response curve, the pattern of amplification provided by the hearing aid may be varied according to its components.

As we measure the hearing sensitivity of the individual, so do we measure the sensitivity of the amplifying system at each frequency, in a frequency response curve.

To find out the frequency response of a hearing aid, sounds of different frequencies can be sent through the microphone at one end and measured at the other end, when they come out of the receiver. This graph can be shown as -

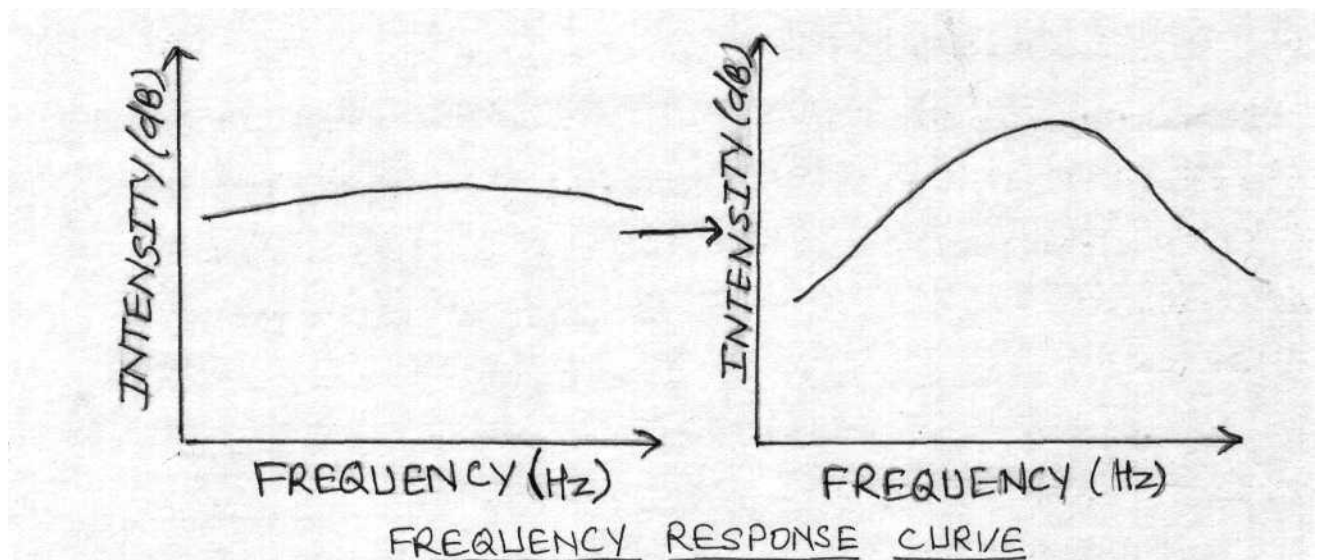

(Hertz - Hz being a unit of frequency)

The standard frequency response is generally obtained at a lower gain setting i.e. volume setting than the maximum possible setting. Frequencies from 300 Hz to 5000 Hz are all sent in at the same intensity level. Frequency response

characteristics of many aids do not, generally, extend beyond this range, as good comprehension or understanding of conversational speech, can be achieved within this range of 300 Hz to 5000 Hz.

Though frequencies from 300 to 5000 Hz are sent in at the same intensity level, when they are measured on coming out of the receiver, some frequencies are found to be at a higher level than the others, giving a frequency response curve.

**FREQUENCY RANGE:**

The frequency range of an aid refers to the useful range of the frequency response. It is expressed by two numbers, one representing the low frequency limit of amplification and other high frequency limit, both the numbers are expressed in Hertz (Hz).

Thus, from the frequency response curve, the frequency range for the hearing aid can be calculated.

With each hearing aid, the manufacturers are expected to supply the information regarding the frequency range of the hearing aid. The user must be aware that the frequency response of the hearing aid and for calculating the frequency range. Standards are specified by the National Standards Institution. Also,



the hearing aid user may ensure that the frequency range specified by the manufacturer is measured and calculated as per the prescribed procedure by this Institution.

**SATURATED SOUND PRESSURE LEVEL OR MAXIMUM OUTPUT LEVEL(SSPL):**

It is the sound pressure level obtainable in the coupler from the receiver of a hearing aid at any frequency from 200 Hz to 8000 Hz. It is the output level that cannot be exceeded, regardless of how far the gain control or volume control is turned or how intense the input signal is i.e. even if the input is increased or gain control is turned to maximum, the output does not exceed certain level. Maximum sound pressure level at all frequencies must be less than the sound pressure level that causes discomfort or pain at that frequency. The graph of maximum sound pressure level is as follows:

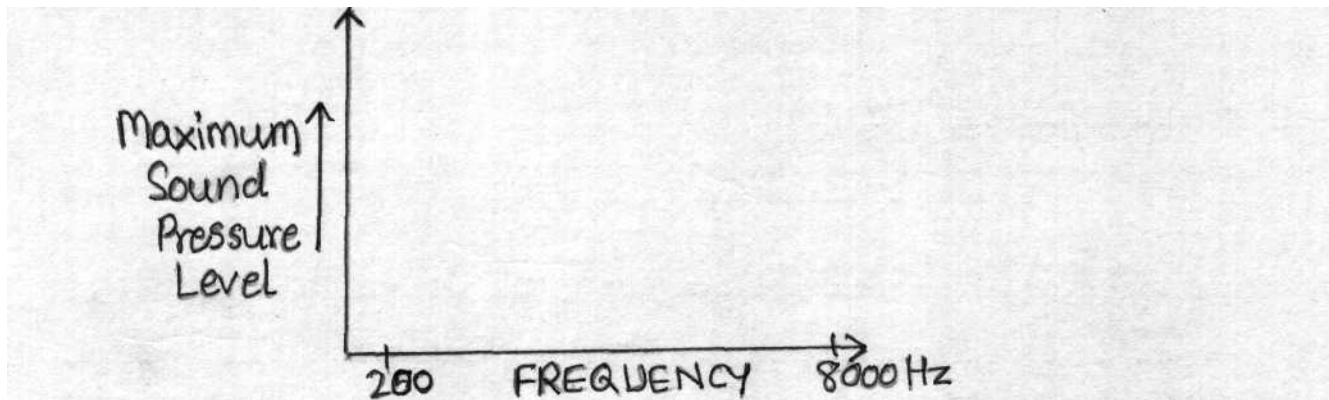

This maximum output can be used as a safety factor against sounds that might be harmful or uncomfortable.

**EQUIVALENT INPUT NOISE LEVEL:**

This term refers to the noise heard from the hearing aid, even when there is no sound reaching the microphone i.e. the difference between the noise when there is input and no input is the noise generated by the circuitry of the hearing aid. The moment the hearing aid is switched on this sound starts coming.

This sound should not exceed the maximum limit that is specified in the standards for a particular model of a hearing aid. These standards may be national or international.

**DISTORTION:**

Distortion occurs in the hearing aid, when the output signal differs from the original signal, in other words, distortion occurs when input signal is not faithfully reproduced

As distortion increases, it becomes difficult to identify the original signal. Therefore, distortion should not exceed a particular limit, which is usually expressed in percentage. For example, if the limit is x%, then it means that the level of the distortion products should not exceed x% of the level of the original signal. Thus, the word distortion refers to any change in the original sound signal.

**Types of distortion:**

The main types are : Harmonic distortion and Intemodulation distortion.

But only harmonic distortion is included in the present Bureau of Indian Standards pertaining to hearing aids as it is easily measured.

A harmonic distortion occurs when the output signal contains sounds of frequencies that are multiples of the original sound frequency. For example, if the input to a hearing aid is a 1000 Hz signal then harmonic distortion would cause a signal to be produced by the hearing aid at 2000 Hz, at 3000 Hz and so on, even though these were not part of the signal presented to the hearing aid.

Percentage of distortion for a particular frequency provides the range in which new frequencies have been generated. Here, new frequencies refer to those frequencies that were not present in the input signal.

3% of distortion at 3000 Hz means some new frequencies have been generated in the range  $\pm 3\%$  of 3000 Hz i.e. 2910 Hz to 3090 Hz.

Distortion permitted at each frequency may be obtained from the 'National Standards Institute' or from your Audiologist.

Measurement of these electroacoustic characteristics need special instrumentation, which will be present with the manufacturers. Some of the speech and hearing centers and dealers of the hearing aids may also have this instrumentation. Every hearing aid manufacturer must specify values of all these characteristics for all the hearing aids so that the hearing aid prescription becomes an easy procedure.

### GUIDELINES FOR PURCHASE OF HEARING AID

Choice of a good hearing aid is the first step in the rehabilitation of a patient with hearing loss. By means of a hearing aid, the residual hearing is made maximum use of. A hearing aid does not restore hearing to normal i.e. it is not as if, new ears have replaced the damaged ones. The amount of benefit derived from the use of a hearing aid varies from individual to individual.

The hearing aid user must know that the benefit derived from the aid is limited, so he/she should not get disappointed after the purchase of the hearing aid. To what extent, the use of a hearing aid is beneficial in an individual case may be ascertained at the time of hearing aid trial.

Hearing aid helps in detecting the presence of sound and in understanding speech. Thus, it helps in becoming aware of the danger. So, the hearing aid would serve to warn the users of approaching vehicles.

All hearing aids are not alike. Some are worn in the pockets with the receiver in the ear, some may be worn behind the ear. Some look like spectacles but also have the necessary components to make the sounds louder for the patient with hearing loss. Some hearing aids are very small which are worn inside the ear, and are not noticeable easily. Some are big enough to be noticed very easily.

Hearing aids vary in terms of their size, appearance and also in terms of how powerful they are. The type of hearing aid for a patient is determined by his/her needs, desires and financial status.

All hearing aid purchasers/users must have medical examination of their ears before purchase of a hearing aid for the well being and safety of themselves. Such an examination should also be followed periodically; may after every six months or one year.

Thus, hearing aids are normally recommended when-

- 1) Medical/surgical treatment is not indicated to revert the hearing to normal.
- 2) Surgical treatment is decided against for a number of reasons.
- 3) Surgical/medical treatment is given but improvement in hearing is not sufficient to preclude use of a hearing aid.
- 4) Surgery is possible, but the patient opts for a hearing aid.
- 5) Surgery is awaited and hearing aid is to be used in interim period.

In all such cases, selection and acquisition of hearing aid becomes essential for the individual with hearing loss.

**Points to be noted:**

- 1) Before purchase, the user must have a trial with different types/models of hearing aids to choose the one that gives him/her the optimum benefit. For this reason, prior to purchase of a hearing aid, the potential user must visit a speech and hearing professional, where he would have the opportunity to try out different models and seek professional guidance. Hearing aids must be purchased only on the recommendation of a qualified professional i.e. an Audiologist.
- 2) Before purchasing, the user must first ascertain that this particular model provides him the required help. Though, cosmetic value is important, it should not outweigh the consideration of amplification needs.
- 3) It is useful to know, how powerful a hearing aid is and also some other characteristics. More powerful hearing aid must not be the one always preferred. Purchase of a hearing aid, that is more powerful than the one actually required by the user must be avoided.
- 4) Different models of hearing aids can be purchased within the country. Some users may feel that if a hearing aid is imported or otherwise got from a foreign country it would serve them better. Such users must remember that -
  - (a) It is preferable to purchase an aid after a hearing aid trial
  - (b) Hearing aid required periodical servicing

and replacement of spares which may be more difficult to procure for the imported hearing aids. And, the spares of these hearing aids may not be available in our country.

- 5) Here, one more important point is, it is not wise to buy a hearing aid by mail, if there is any practical alternative. Direct personal contact with the dealer is most desirable, as nearness of a dealer is a great advantage for inspection and trial of a hearing aid. It is also useful for subsequent repair and replacement service.
- 6) Also, specific inquiry should be made about the availability and quality of the spares and cost of service, including the replacement of cells.

#### **Repairs and Servicing:**

- 1) The hearing aid must be serviced periodically to ensure long term usage.
- 2) The user must explore the possibilities of getting his/her hearing aid repaired/serviced in a place that is easily accessible.
- 3) It must be remembered that a hearing aid must have its troubles attended to, by a qualified person i.e. they must be repaired/serviced only by a qualified personnel.
- 4) Nearness to a dealer is also important. If repair service is not immediately available, the user may be deprived of his instrument for longer periods of time.



- 5) Unnecessary repairs at exorbitant prices are to be avoided and the user should be careful against being "high-pressured" into buying a new model of a hearing aid to substitute for an older model that happens to get out of order. So, the user must always contact a reliable person for repairs and servicing.

**Purchase of components of the hearing aid:**

- 1) At the time of sale, the hearing aid is given along with its accessories which include a receiver, an appropriate cord, an appropriate cell, a clip for a body worn hearing aid. These are placed in a case which gives adequate protection against dust and dirt.
- 2) The user would benefit, if he actually learns to connect the various accessories, prior to leaving the shop.
- 3) More important, he must make sure that he is getting the hearing aid, that was recommended for his use. The particulars regarding the model, recommended for his use, are normally inscribed on the hearing aid. Similarly, information on the receiver type can be seen on the receiver.
- 4) After connecting the accessories, the functioning of the hearing aid should be checked. Is the sound amplified and transmitted to the ear properly? Is the sound continuous or intermittent? Is there unnecessary noise, when

the switches, volume control is moved around? Are there loose contacts or broken parts? All these points should be checked carefully.

- 5) Hearing aids in addition to varying in size and power differ in some other respects. For instance, some hearing aids are equipped with circuitry that will permit using the hearing aid with telephone, while cutting out the background noise, that would otherwise interfere with conversation.

Some hearing aids are meant for people who are unable to tolerate loud sounds even though they have hearing loss. This type of hearing aid would be recommended by the audiologist after confirming that the patient has a tolerance problem.

These and other factors are taken into consideration at the time of hearing aid trial and recommendations for the appropriate model are made. But the user should check all these points and must have a hearing aid trial prior to purchasing the same hearing aid.

- 6) In addition to these technical aspects, consideration for selection of a particular model may include recurring expenditure in replacing batteries, other accessories as the cord, receiver and switches.

- 7) While purchasing spares, the following points should be noted. You should always buy only the recommended spares.
- a) **Type of receiver** - Provided is the same as the one mentioned by an audiologist or not. Always matching receivers should be purchased. Washer on the receiver should be intact, otherwise there would be leakage of sound energy.
  - b) **Cord:-** Where it is 2-pin or 3-pin. Whether it is 'S', 'V' or 'Y' cord, according to the prescription by the audiologist. Cord length should be appropriate i.e. 50 cms. Cord should be checked carefully to detect any breaks along its length. Keep a spare cord, particularly if the dealer is not near.
  - c) **Cell:-**Type and size of cell should be checked. All pentarch cells do not fit with all the hearing aids, find out which will be most appropriate for your hearing aid.

Different types of cells; pentarch cells, button cells are used with different hearing aids. Of these, the pentarch cells are easily available and they are less expensive. It has a voltage of 1.5 volts and is most commonly used with body worn hearing aids. The button cells are used with hearing aids worn at the ear level and are more expensive.

Periodical replacement of the cells should also be done. For getting optimum usage, a regular user, must change hearing

aid cells once in 8-10 days for bodylevel hearing aids. For ear level hearing aids, where button cells are used, generally cells should be replaced after 100 hours of usage.

There are special cells which can be recharged and used again. These cells may be available with the dealer.

Process of recharging the cell is not economical in body level hearing aids as -

- 1) A cell in body level hearing aids, costs less and at the most two or three cells may be needed in a month for a regular user.
- 2) While, the recharger instrument of a body worn hearing aid is bulky and the process of recharging takes around 10-12 hours. Also, the user has to always carry one spare cell with him, which he can use when the cell is being recharged. Thus, the process of recharging is time consuming. So, it is preferable, to buy a fresh cell, instead of recharging the old cell, which is more economical as the cost of a cell in such a hearing aid is also less.

Purchase of rechargeable cells for the Ear level hearing aid may be indicated for the following reasons:

- 1) A cell costs Rs.15-20.
- 2) The recharger instrument is very small and it can be carried in the pocket. So, for a tegular user it can be economical as he does not have to spend more money on the cell, though the process is still time consuming.

So, depending on whether the user can afford to buy a recharger and is willing to spend some time for the process, a recharger is advised.

One such button or pencil cell can be recharged for about totally 500 times, but it can vary according to the company which has manufactured it.

- d) Volume control:- Whether it is numbered or not. Check is the switch is rotating smoothly or not.
  - e) Tone control:- Whether it is present and functioning well or not. If it is internal, then adjustments should be done by the dealer before the user purchases a hearing aid.
  - f) Check for the presence of a/separate on-off switch.
  - g) Earmolds:- If provided by the company, see if they fit properly. Some of the dealers provide eartips i.e. small plastic tubes instead of earmolds. But it is advisable, to get custom earmolds done as they fit properly.
  - h) Telecoii:- Whether it is present or not, especially for adult cases who are frequent telephone users. If present whether functioning well or not.
  - i) Dust cover:- It is provided with some hearing aid models to avoid dust collecting on the hearing aid switches.
  - j) Check for the hearing aid clip in body worn hearing aid to keep the hearing aid properly when worn on the body.
- 8) serial number of a hearing aid is also important in identification of your hearing aid.

The information pertinent to hearing aid type, model and serial number helps -

- 1) In the identification of your hearing aid in the spent of loss/theft.
- 2) In ensuring that you receive the same hearing aid after repair.
- 3) In giving complete information regarding your hearing aid to the audiologist

**Cost:**

It is an important factor in purchase of hearing aid. Before purchase, you should ask the audiologist regarding the cost of the prescribed hearing aid.

The cost of a body level hearing aid ranges from Rs+450/- to Rs.1,800/-. The cost of an ear level hearing aid ranges from Rs.1,700/ to Rs.3,000/-.

Sometimes, the dealers may try to mislead the purchaser. Some dealers may charge/<sup>for</sup>the hearing aid depending on patient's/parent's income. So a purchaser should be aware of such practices. He should check the cost factor Carefully before the purchase.

Also, the purchaser must ask for a receipt and the guarantee card which must be filled in. This helps in getting the repairs done free of cost during the guarantee period.

The buyer must get the guarantee card filled. In some cases, guarantee cards are not given. Even if they are given the details are not filled out, or the card is given but it is taken back on a subsequent visit. The user should be aware of such practices.

Thus, before purchase of a hearing aid, three major items of expense should be noted as - the initial cost, repairs and replacement, cell expenses. Low cost of one of these items does not necessarily means low cost of others.

It is also recommended that the hearing aid be tried on the patient and its utility established, before purchase of a hearing aid. After purchase, every user should visit the audiologist to ensure that he has received the right hearing aid.

The purchaser must remember that a hearing aid should be accompanied by the following information as -

- 1) Illustration of the hearing aid showing controls, adjustments and cell compartments.
- 2) Printed material on operation of all controls designed for user adjustment.
- 3) Description of possible accompanying accessories such as telecoil for specialized provisions for listening over telephone.

- 4) Instructions on how to use, maintain and take care of, as well as replace or recharge the cells.
- 5) How to and where to get the hearing aid repaired.
- 6) Conditions to be avoided in preventing damage to hearing aids, such as dropping or exposing to excessive heat or humidity.
- 7) Selected electroacoustical data obtained in accordance with the respective standard (this information may be included on separate labeling that accompanies the hearing aid).

If the above points are kept in mind, the chances of an individual with hearing loss, purchasing an aid that suits him best and to derive maximum benefit from it are maximised.



### SUMMARY

Given the current situation in India, hearing aid seems to be one of the major solutions in effective management of the aurally handicapped. Consequently, it becomes the responsibility of everyone concerned with hearing aids, to be well versed with the intrinsic mechanism and characteristics of the amplification device. This will not only ensure successful rehabilitation but also give a major lead in the improvisation and further sophistication of the hearing aid device.

Thus, in the preceding chapters, an attempt has been made to bring to all those concerned, the characteristics and functions of the hearing aids.

The electroacoustic characteristics have been specially highlighted because of their significant role in not only designing of hearing aid but also in monitoring their performance over time.

Purchase of any commodity involves investment. And, investment involves scrutiny! But, scrutiny requires knowledge. So it is, with hearing aids. Thus, guidelines on the purchase aspects of hearing aids have also been included, so that, it would be useful for any client in purchasing an appropriate hearing aid.

Last, but not the least, this guide is not the end. It is only a means to the end!!

**BIBLIOGRAPHY**

- Alpiner, J. (1978): Evaluation of communication function. In J.Alpiner (Ed), Handbook of adult rehabilitative audiology. Chapter 3, 30-66, Williams and Wilkins, Baltimore.
- Alpiner, J., (1978): Rehabilitation of the geriatric client. In J.Alpiner (Ed), Handbook of adult rehabilitative audiology. Chapter 7, 141-170, Williams and Wilkins, Baltimore.
- Berger, K.W., Millin, J.P. (1978): Hearing aids. In D.E.Rose (Ed), Audiological assessment. Chapter 14, 495-538, 2nd Edn. Prentice-Hall, Englewood Cliffs.
- Berger, K.W. (1980): History and development of hearing aids. In Pollack, M (Ed), Amplification for the hearing impaired, Edn.2, Chapter 1, 1-20, Grune and Stratton, New York.
- Brlekey, R.J., (1978): Binaural hearing aids and new innovations. In J.Katz (Ed), Handbook of clinical audiology, Hdn.2, Chapter 41, 501-507, Williams and Wilkins, Baltimore.
- Brooks, D., (1973): Gain requirements of hearing aid users. Scandinavian Audiology, 2(4), 199-205.
- Chermak, G.D., (1981): Amplification. In Chermak, G.D., Handbook of audiological rehabilitation. Chapter 9, 185-247, Charles Thomas Publisher, Illinois.
- Chermak, G.D., (1981): Measurement in audiological rehabilitation. In G.D.Chermak, Handbook of audiological rehabilitation. Chapter 10, 248-258, Charles Thomas Publishers\* Illinois.
- Chial, M.R., Hayes, C.s., (1974)\$ Hearing aid evaluation methods: Some/underlying assumptions. Journal of Speech and Hearing Disorders, 39(3), 270-279.
- Denes P.B., Penson, E.N. (1973): The physics of sound. In p.B.Denes, and B.N.Binson, The speech chain: The physics and biology of spoken language. Chapter 3, 19-50, Anchor Press/Doubleday, New York.

- Grab, B. (1917): Batteries. In Bernard, Grob, Basic Electronics, Edn.4, Chapter 12, 240-262, McGraw Hill Kogakusha Ltd., London.
- Hartbauer, R.E. (1975): Electronic amplification. In R.E. Hartbauer, Aural rehabilitation. Chapter 3, 19-25, Charles Thomas Publisher, U.S.A.
- Haughton, P.M. (1980): Hearing aids. In P.M. Haughton, Physical Principles of audiology, Chapter 7, 148-165, Adam Hilger Ltd., Bristol.
- Hodgson, W.R. (1986): Clinical measures of hearing aid performance. In H.R. Hodgson, P.H. Skinner (Eds), Hearing aid assessment and use in audiologic habilitation, Edn.2, Chapter-8, 152-170, Williams and Wilkins, Baltimore.
- Hodgson, W.R., (1986): Learning hearing aid use\* In W.R. Hodgson and P.H. Skinner (Eds), Hearing aid assessment and use in audiologic habilitation, Edn.2, Chapter 11, 212-225, Williams and Wilkins, Baltimore.
- Jerger, J., Speaks, C., Malmquist, C. (1966): Hearing aid performance and hearing aid selection. Journal of Speech and Hearing Research, 9(1), 136-149.
- Kasten, R.M., Franks, J.R., (1977): Electroacoustic characteristics of hearing aids. In W. Hodgson and P. Skinner (Eds), Hearing aid assessment and use in Audiologic habilitation, Edn.2, Chapter 4, 44-72, Williams and Wilkins, Baltimore.
- Kasten, R.M., (1978): The hearing aid as related to rehabilitation. In J.G. Alpiner (Ed): Handbook of adult rehabilitative audiology. Chapter 4, 67-87, Williams and Wilkins, Baltimore.
- Kenneth, B.W., Gaydos, M.L., (1984): Public attitude towards hearing aid amplification, Audicibel, 33(4), 20-27.
- Leavitt, R., (1977); Earmolds: Acoustic and structural considerations. In W. Hodgson and P. Skinner (Eds) Hearing aid assessment and use in audiologic habilitation, Edn.2, Chapter 5, 73-114, Williams and Wilkins, Baltimore.

- Levitt, H., (1978): Methods for the evaluation of hearing aids in Ludvigsen, and J. Barfod (Eds), Sensori-neural hearing impairment and hearing aids. Chapters, 199-240, The Almquist and Wiksell Periodical Company, Stockholm.
- Lyberger, S., (1974): Electroacoustic measurements. In K. Donnelly (Ed), Interpreting hearing aid technology. Chapter 2, 40-84, Charles C Thomas Publisher, Illinois.
- Lyberger, S., (1978): Earmolds. In J. Katz (Ed) Handbook of Clinical Audiology, Edn. 2, Chapter 42, 508-523, Williams and Wilkins, Baltimore.
- Martin, P.N., (1975): Audiological management of the patient. In P.N. Martin, Introduction to Audiology, Chapter 12, 393-421, Prentice Hall, Englewood Cliffs, New Jersey.
- McCandless, G.A., (1979): Real ear measure of hearing aid performance. In P. Yanick, (Jr), Rehabilitation strategies for sensori-neural hearing loss. Chapter 4, 75-88, Grune and Stratton, New York.
- Millin, J.P., (1977): The electroacoustic dimensions of hearing aids. In P. Yanick, (Jr), The application of signal processing concepts to the hearing aids, Chapter 6, 125-138. Grune and Stratton, New York.
- Millin, J.P. (1978): Panel discussion Hearing aid selection, fitting and post fitting procedures. In P. Yanick (Ed), Rehabilitation/strategies for sensori-neural hearing loss. Chapter 12, 191-209, Grune and Stratton, London.
- Newby, H., Popelka, G.R., (1985): The handicap of hearing impairments. In H. Newby, G.R. Popelka, Audiology. Edn. 5, Chapter 10, 358-389, Prentice Hall Inc. Englewood Cliffs, New Jersey.
- Niemoller, A., Silverman, S., Davis, H., (1970): Hearing aids. In H. Davis, and Silverman, S. (Eds), Hearing and deafness, Edn. 3, Chapter 10, 280-317, Holt, Rinehart and Winston, Chicago.
- Olsen, W.O., (1976) Proposed American National Standards Institute for specification of hearing aid characteristics. In M. Rubin (Ed): Hearing aids; Current developments and concepts. Chapter 2, 65-78, University Park Press, Baltimore.

- Olsen, W.O., (1977): Physical characteristics of hearing aids. In W.Hodgson, and P.Skinner (Eds). Hearing aid assessment and use in audiologic habilitation, Edn. 2, Chapter 3, 19-43, Williams and Wilkins, Baltimore.
- Pollack, M., (1980): Electroacoustic characteristics. In M.Pollack. (Ed), Amplification for the hearing impaired//Chapter 2, 21-87. Grune and Stratton, New York.
- (ed)
- Roeser, R.J., (1980): Hearing aids. In R.W.Keith/Audiology for the physician. Chapter 11, 239-266, Williams and Wilkins, Baltimore.
- Ross, M., (1978): Hearing aid evaluation, In J.Katz (Ed): Handbook of clinical audiology, Edn.2, Chapter-43, 524-542, Williams and Wilkins, Baltimore.
- Sanders, D.A., (1971): Amplification and hearing aids. In D.A.Sanders, Aural rehabilitation. Chapter 6, 132-201, Prentice Hall Inc, Englewood Cliffs, New Jersey.
- Schmitz, H.F., (1980): Hearing aid selection for adults. In M.Pollack (Ed), Amplification for the hearing impaired, Edn.2, Chapter 5, 177-208, Grune and stratton. New york.
- Silverman, S.R., Davis, H., (1980): Counselling about hearing aids. In H.Davis, and S.silverman (Eds), Hearing and deafness, Edn. 3, Chapter 11, 378-332, Holt, Rinehart, and Winston, Chicago.
- and
- Traynor, R.". (1982): Hearing aid counselling/orientation for the elderly. In R.Hull (Ed), Rehabilitative audiology. Chapter 24, 355-374, Grune and stratton. New York.
- Yost, W.A., Nielsen, D.W., (1977): sound transmission. In W.A.Yost, D.W. Neelsen, Fundamentals of hearing. Chapter 2, 14-22, Holt, Rinehart and Winston, Chicago.