

**QUEST ON AUDIOLOGY: LEARNING THROUGH VISUALS**

Reg.No. M 9411

AN INDEPENDENT PROJECT WORK SUBMITTED IN PART FULFILMENT  
FOR FIRST YEAR M.Sc. (SPEECH AND HEARING) TO THE  
UNIVERSITY OF MYSORE.

ALL INDIA INSTITUTE OF SPEECH AND HEARING,  
MYSORE 560 006

MAY 1995.

DEDICATION.

Ma, Bapi, Bhai and Mitu

"You MEAN THE WORLD TO ME".

**CERTIFICATE**

This is to certify that the Independent Project entitled: **"QUEST ON AUDIOLOGY: LEARNING THROUGH VISUALS"** is a bonafide work, done in part fulfilment for the Degree of Master of Science (Speech and Hearing) of the student with Reg.No. M 9411.

MYSORE  
MAY 1995

  
**Dr. (MISS) S. NIKAM**  
**DIRECTOR**  
ALL INDIA INSTITUTE  
OF SPEECH AND HEARING  
MYSORE-6.

**CERTIFICATE**

This is to certify that this Independent project entitled "**QUEST ON AUDIOLOGY: LEARNING THROUGH VISUALS**" is prepared under my supervision and guidance.

MYSORE  
MAY 1995

  
**Dr. (MISS) S. NIKAM**  
**GUIDE.**  
Professor and HOD  
Audiology Department  
All India Institute Of  
Speech and Hearing  
Mysore.

## DECLARATION

I hereby declare that this Independent Project entitled: **"QUEST ON AUDIOLOGY: LEARNING THROUGH VISUALS"** is the result of my own study under the guidance of Dr.(MISS) S.NIKAM, professor and head of the Department of Audiology, and Director, All India Institute of Speech and Hearing, Mysore, and has not been submitted earlier at any University for any other Diploma or Degree.

MYSORE  
MAY 1995.

Reg.No.M 9411.

## ACKNOWLEDGEMENTS

**Dr. (Miss) S. Nikam,** Prof, and H.O.D., Audiology Department, All India Institute of Speech and Hearing, Mysore. "I am indebted to you ma'm for your timely help, guidance, encouragement and patient listening".

**Dr. (Miss) S.Nikam,** Director, All India Institute of Speech and Hearing, Mysore.

I would like to THANK YOU for permitting me to take up this project".

**Vanaja Ma'm & Manjula Ma'm.**

"Thank you ma'm, for your helpful suggestions and guidance throughout the project".

**Anu, Annams and Lakshmi,**

"Words fall short in expressing my love for you. Thanks for making AIISH a home away from home".

**Arun, Manoj, Mohan and Ajay.**

"Far or near you've always been there to cheer me up, lend a helping hand whenever needed. Thank you for making life at AIISH memorable".

**Class-mates.**

"Thanks for being there through the ups and downs of life at AIISH".

**Megha, Shubha, Swathi, Bindu, Nidhi, Vini, Anil, Sarika, Hia, Chandan...**

"A special word of thanks for your support and goodwill".

**Library Staff of AIISH.**

"I am grateful for your constant help with the innumerable books in the library".

## TABLE OF CONTENT

	PAGE NO.
INTRODUCTION	I-III
<b>QUESTIONS</b>	
ANATOMY, PHYSIOLOGY AND PATHOLOGY	1-15
AUDIOLOGICAL EVALUATION	16-35
INSTRUMENTATION	36-46
HEARING AIDS AND ASSISTIVE LISTENING DEVICES	47-62
NOISE	63-79
<b>ANSWERS</b>	
ANATOMY, PHYSIOLOGY AND PATHOLOGY	81-87
AUDIOLOGICAL EVALUATION	88-93
INSTRUMENTATION	94-97
HEARING AIDS AND ASSISTIVE LISTENING DEVICES	98-102
NOISE	103-107
BIBLIOGRAPHY	108-110

## **INTRODUCTION:**

"The ear is the organ of education", wrote Aristotle centuries ago. Had he understood more about the innate nature of language learning in humans he would likely have phrased it - "The ear is the organ of language learning". Our manual deaf friends might object to that interpretation saying that for them the hands and the eyes are the organs of language learning". Yet the obvious fact is that manual communication derives from language that has been developed through the ear and the vocal mechanism.

Therefore AUDIOLOGY is a new health - care profession with the study of both normal and disordered hearing. It evolved as a spin - off from such closely related fields as speech - language pathology, medicine, special education, psychology and hearing - aid instrumentation. In the most literal sense, the term Audiology refers to the science of hearing. A much broader definition of audiology is the discipline involved in the prevention, identification and evaluation of hearing and hearing disorder, the selection and evaluation of hearing aids and the habilitation/rehabilitation of individuals with hearing impairment.

Although these definitions represent commonly accepted descriptions of the profession, they in no way reflect adequately the breadth of the field or the challenges, rewards and self fulfillment that can result from a career in AUDIOLOGY. So, whether your interest centres on serving



people or producing new knowledge through enquiry and study, a career in audiology has much to offer.

You who read this project may be interested in increasing your knowledge with the help of visuals about this organ of hearing and also about the field of audiology with its various branches which has so much to offer.

For those who belong to the closely related fields of audiology such as speech - language pathology, medicine, psychology, hearing-aid instrumentation, this project is a refresher course and an eye-opener to the different aspects of audiology.

Perhaps you are beginning your training to become a professional audiologist. This project could help you in evaluating your past knowledge on the ear, its functions and its various aspects through diagrams and graphs. This could also help you to get an overall picture on the vastness of the field.

An ongoing student of audiology can test his knowledge by trying to solve the questions. This will help to rate his proficiency in the field. One need not be disheartened if he is not able to answer all questions, this is just an eye-opener to check out on deficit areas and to try to bridge all gaps in knowledge.

You may be one of the experts in the field of Audiology. This project may help to make your work simpler and waste less of your precious time in setting questions for your students.

Imperfect hearing comes close to everyone. But, whether you want to help yourself or want to help others, one merely curious, you want to know what can go wrong with your hearing and what can be done about it, this project can help in solving a number of your queries as it deals with the anatomy, physiology and pathology of the external, middle and inner ear. It also covers, through diagrams, the vast areas of hearing aids and noise, the instrumentation in audiology with some recent advances and graphical representation of many phenomena related to Audiology.

It is often desirable to get a feedback as one treads along the unknown. Keeping this in mind, answers to all questions have been provided at the end of each section. The questions are varied to hold the interest of all who might attempt to solve them.

ALL THE BEST !

III

# QUESTIONS

ANATOMY, PHYSIOLOGY AND PATHOLOGY

Q. 1 Label the parts.

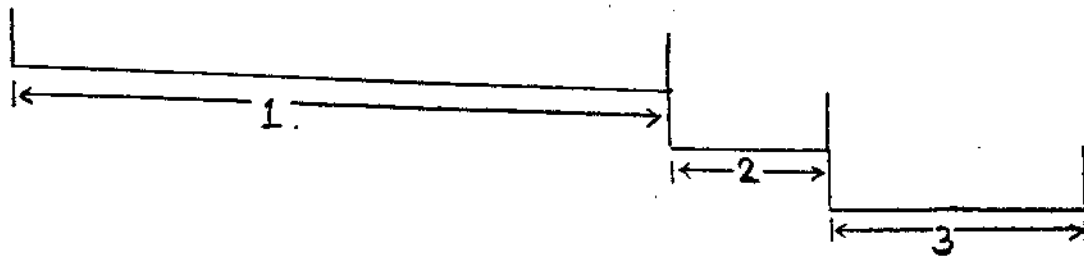
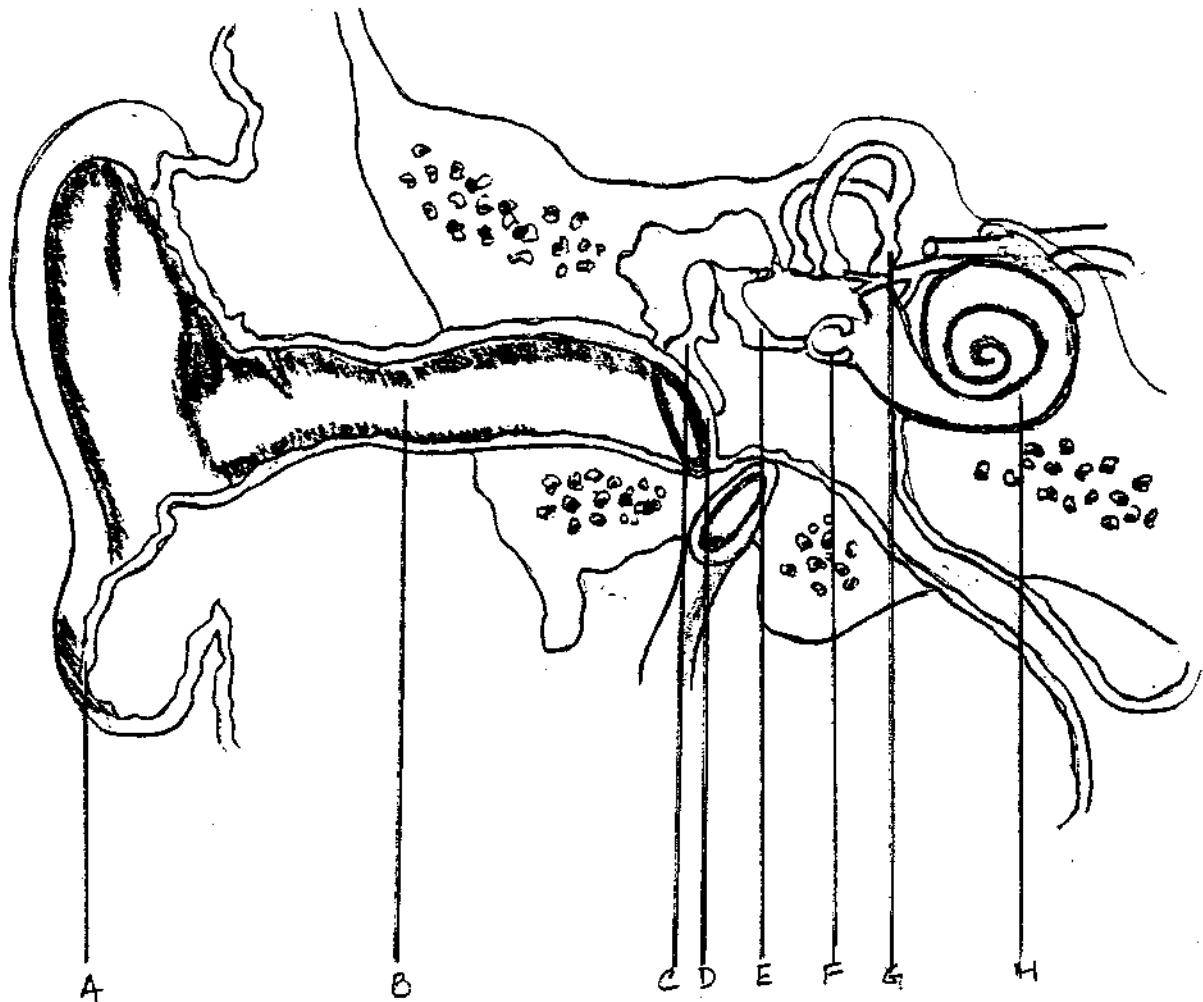

Q.2 a) Can you guess which bone this is ?  
b) Label the parts.

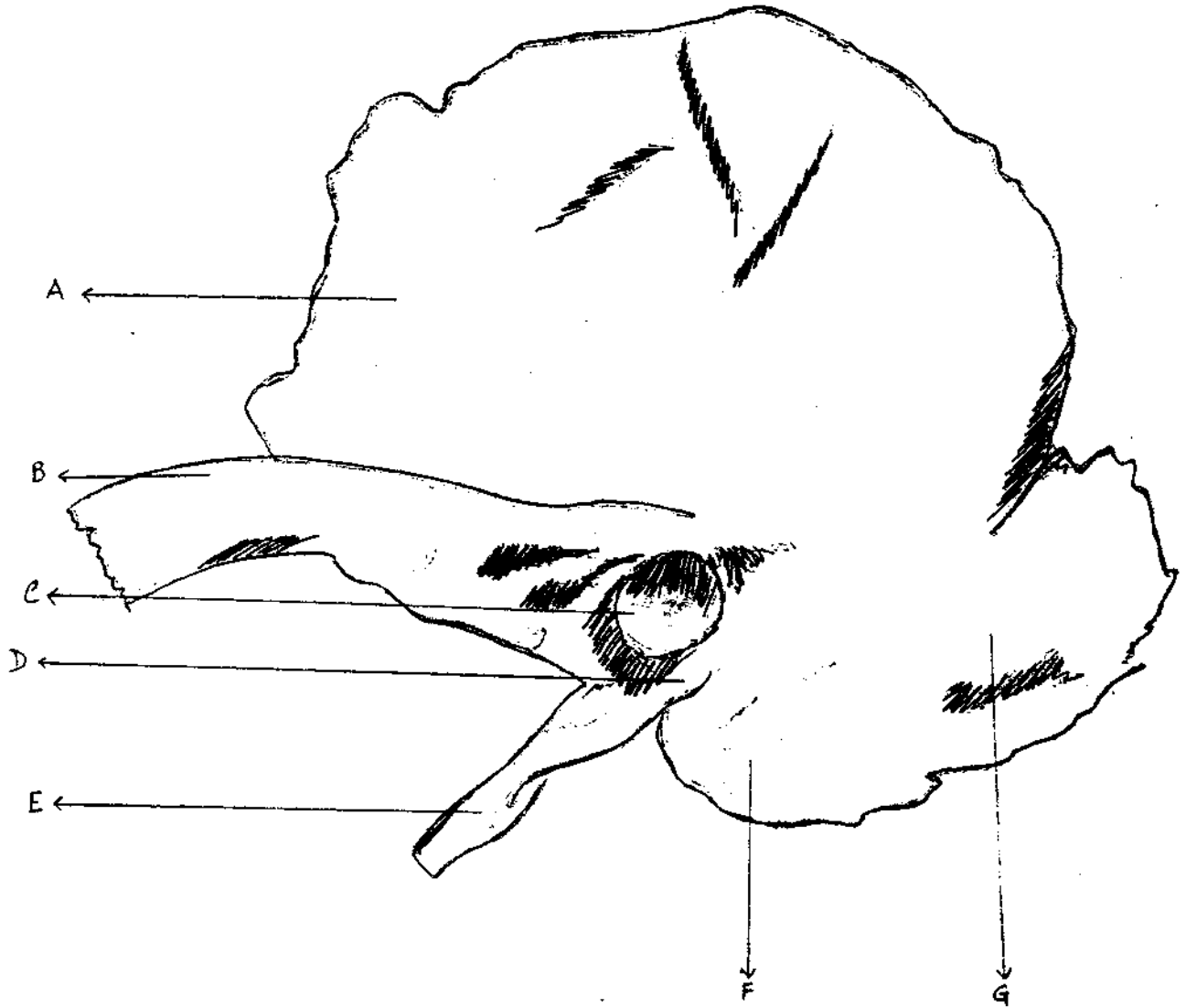

Q.3 Label the parts of dig 1 and correlate it with dig.2 by marking the parts.

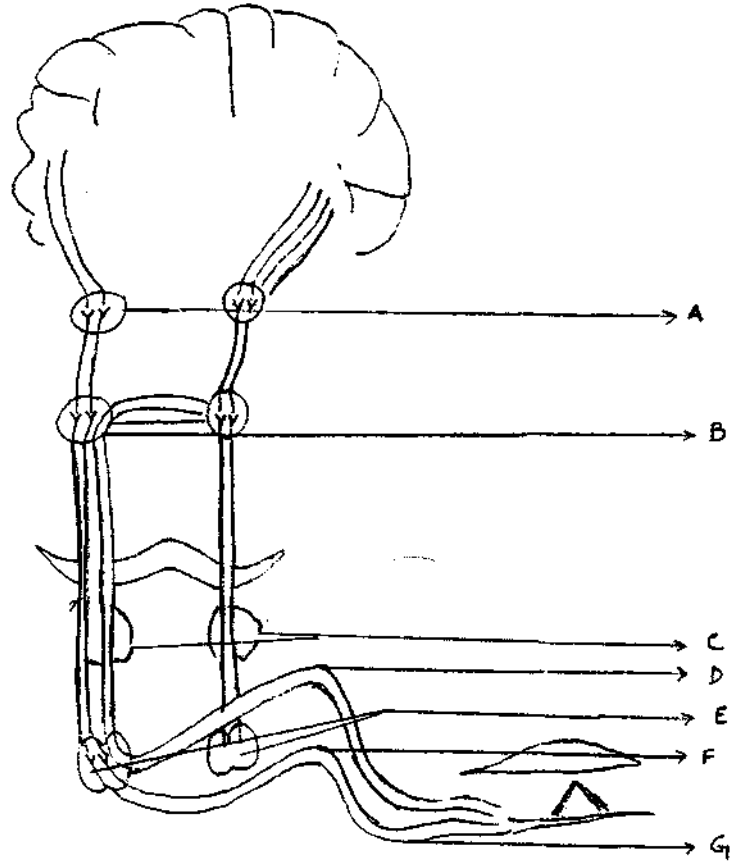

2.

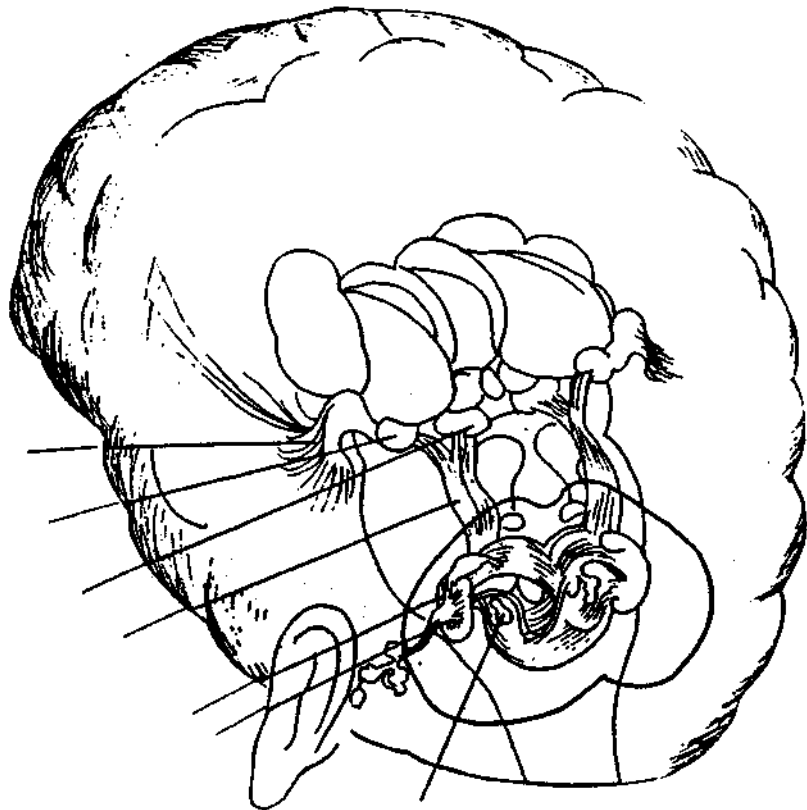

- Q.4 In this jumble are 8 parts of the External Ear.  
 a) Can you find them ?  
 b) Mark them out on the diagram



H B C A S S O F R A L U G N A I R T L T U  
 E X T E R N A L A U D I T O R Y C A N A L  
 L X M A L T X F H E Z L T M P Q R O A C D  
 I B A K O R O N C A T A R O R E K I H O  
 X S B E K A L K N E R T A B H A L O C H I  
 I L U O T S O M O A R K A M O N L A G L O  
 L T O G U M R A C K A A M O N A A C H O I  
 E A I G A I K A J T A B I S H O N B O A R  
 H I A N G R A A N I F E L O B U L E D U  
 I R H O A G T A C H I K I N T U K H U B K  
 T O M K A J B I A K I A A G H E T O B H I  
 N S H O N K H A T R A B L A G C H E N A A  
 A I A K T A L I N N E B A K I A A C H E H  
 L O H C T O N L A G A R T R E T N I I G A

Q.5 Label the parts (a-k) and give its resonance frequency.

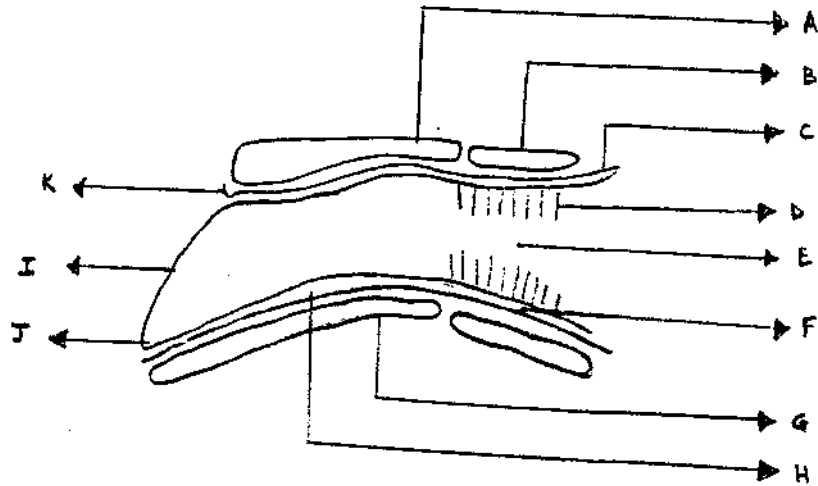

Q.6 a) Name the parts of the membrane,  
 b) Label the quadrants.

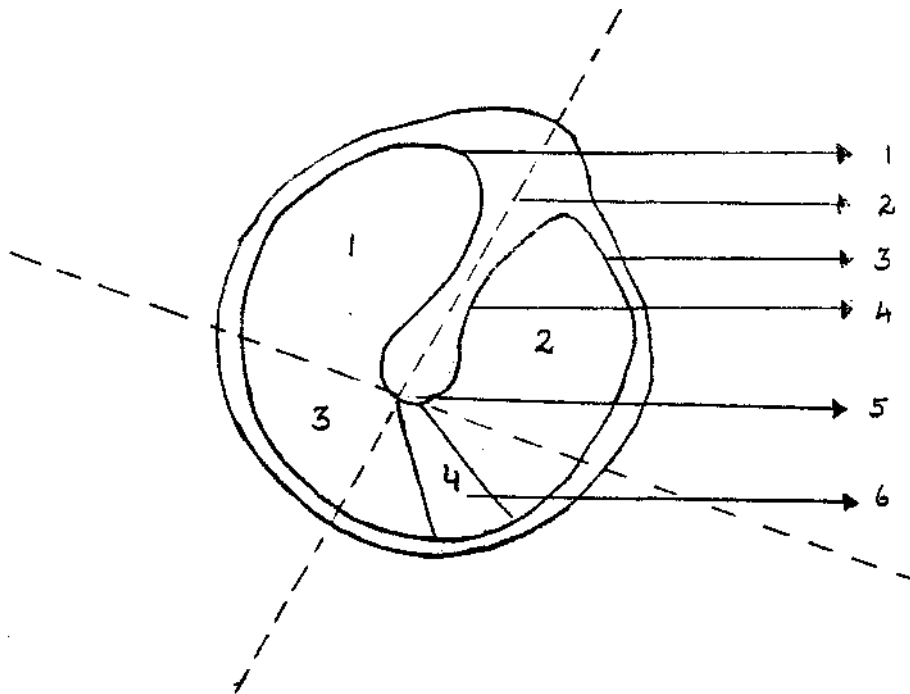



Q.7 a) Your drum below \_\_\_\_\_ Hz shows the following pattern which is known as \_\_\_\_\_ equal \_\_\_\_\_.

b) Identify a and b

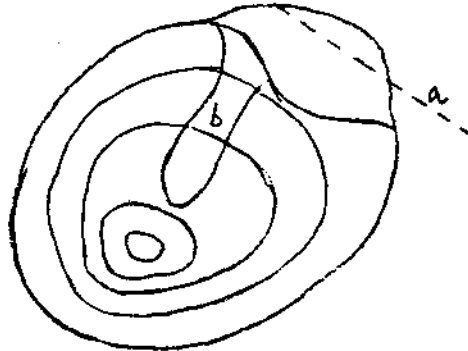

Q.8 a) Match the perforations of the tympanic membrane to the different 'TYPES' based on location,  
 b) These are found in \_\_\_\_\_

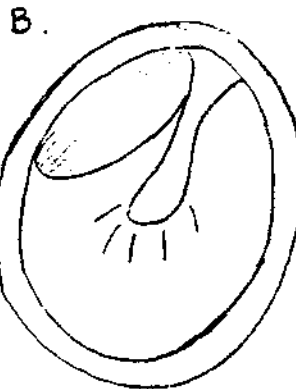

TYPE - 2

TYPE - 3b

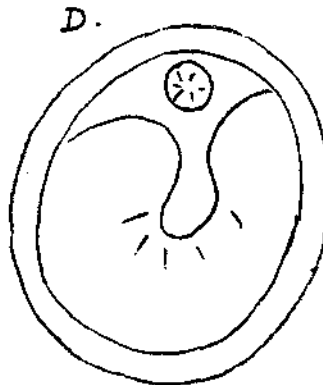
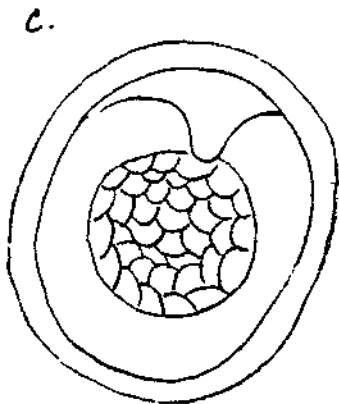

TYPE - 1

TYPE 3a

Q.9 Doesn't this look like a box to you ?  
 a) Guess what it is  
 b) Locate the parts using their numbers.

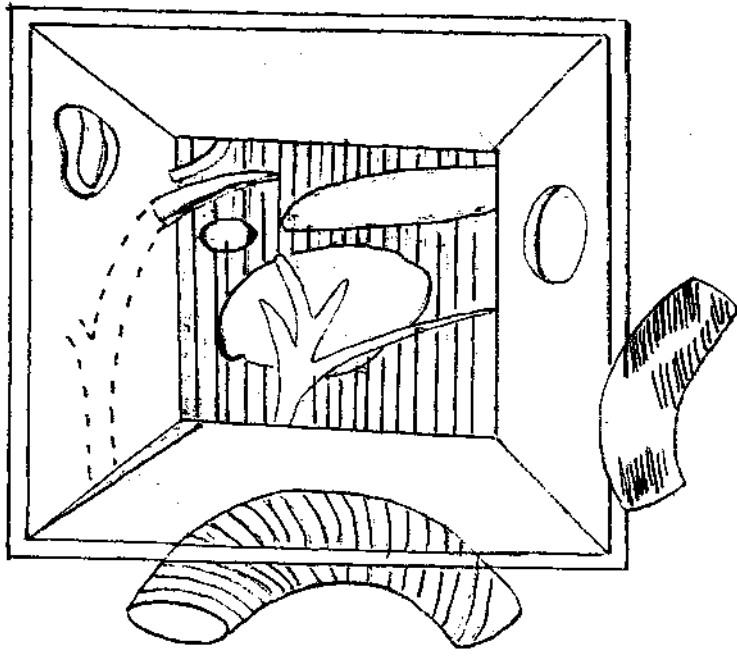

- 1) Promonotary
- 2) Carotid canal
- 3) Aditus
- 4) Fenestra cochleae
- 5) Facial nerve canal
- 6) Tegmen vestibuli
- 7) Fenestra vestibuli
- 8) Tubal opening
- 9) Jugular fossa
- 10) Chorda tympani

Q.10 Why don't you try your artistic skills ?  
 Complete these diagrams and then label them.

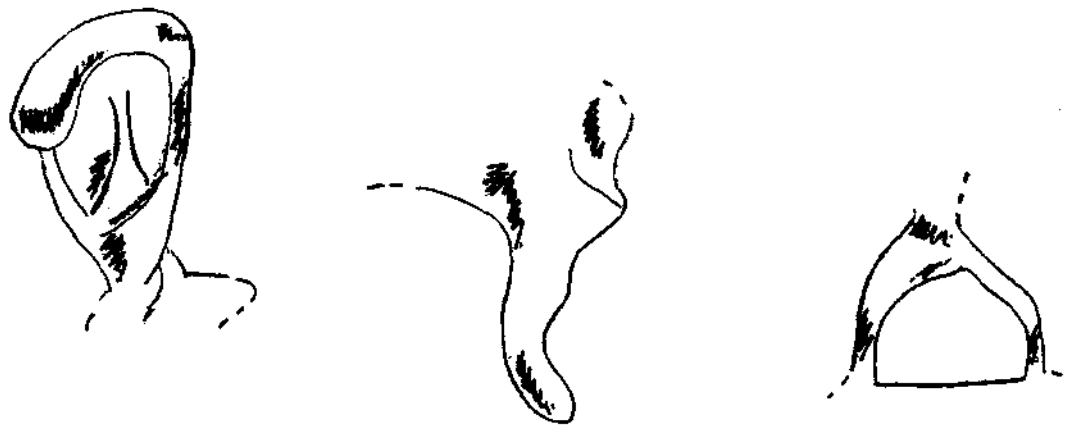

Q.11 Mark the main direction of the ossicular chain movement with the help of arrows.

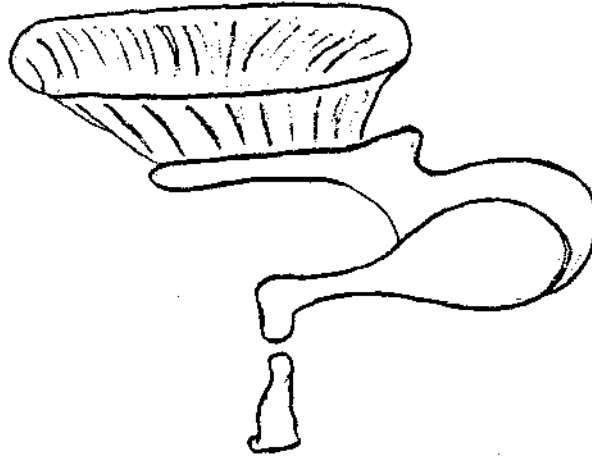

Q.12 Can you tell what this diagram represents and relate it.

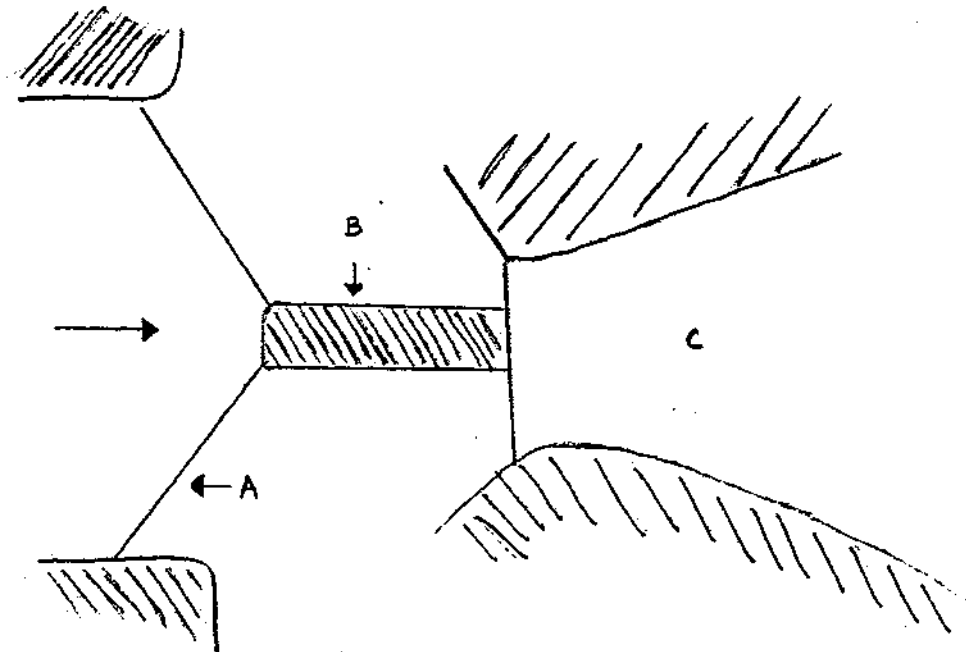

Q.13 Name and draw the missing parts in the ossicular chain.

(1)

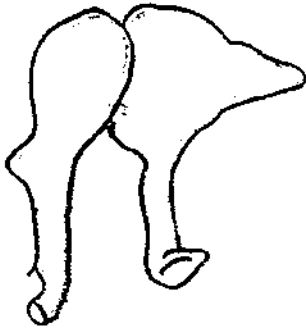

(2)

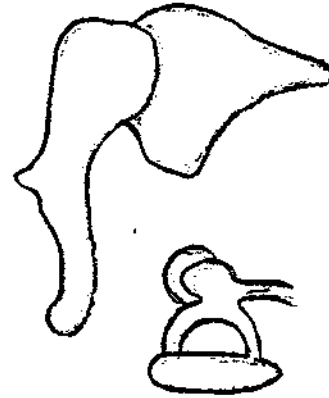

(3)



(4)

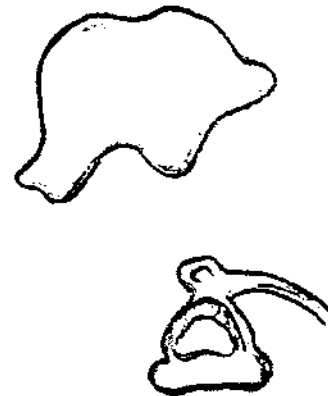

Q.14 a) Label these parts of the Inner ear.  
b) How are figures 1 and 2 different ?

FIG. 1.

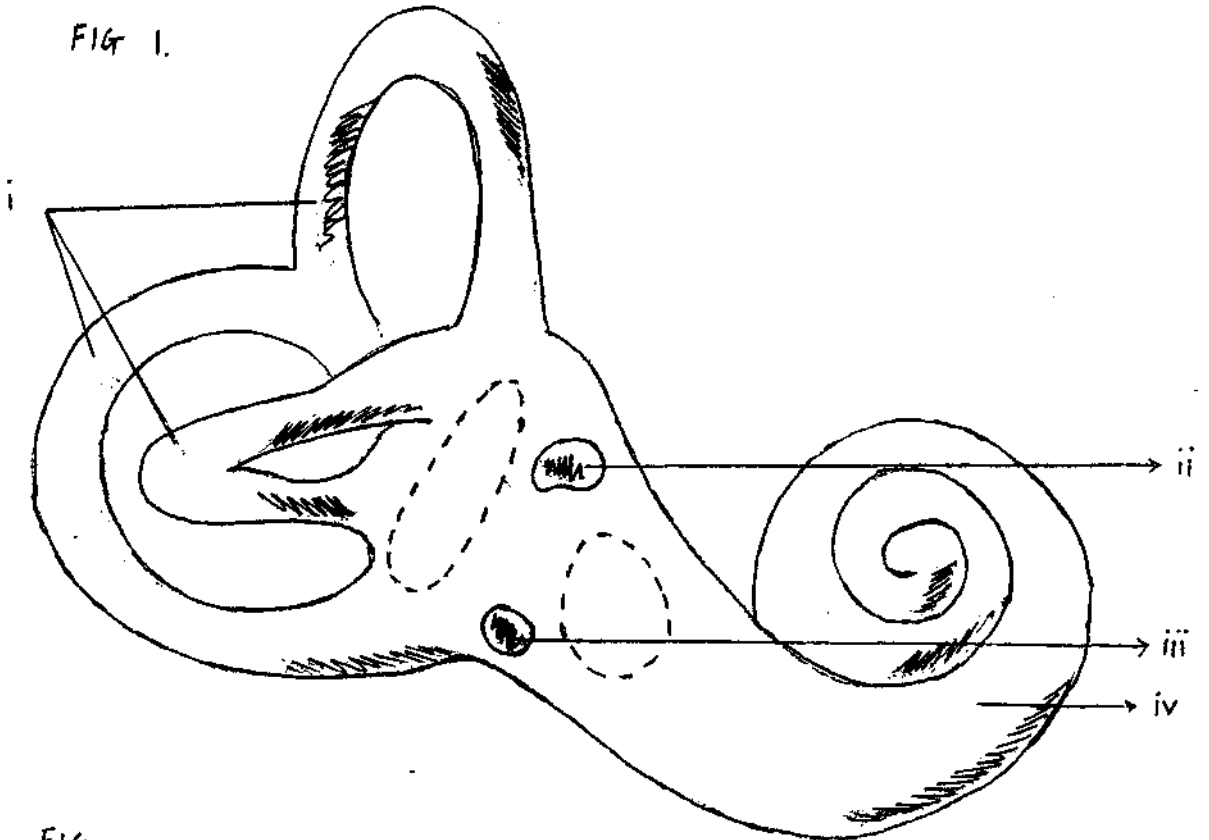
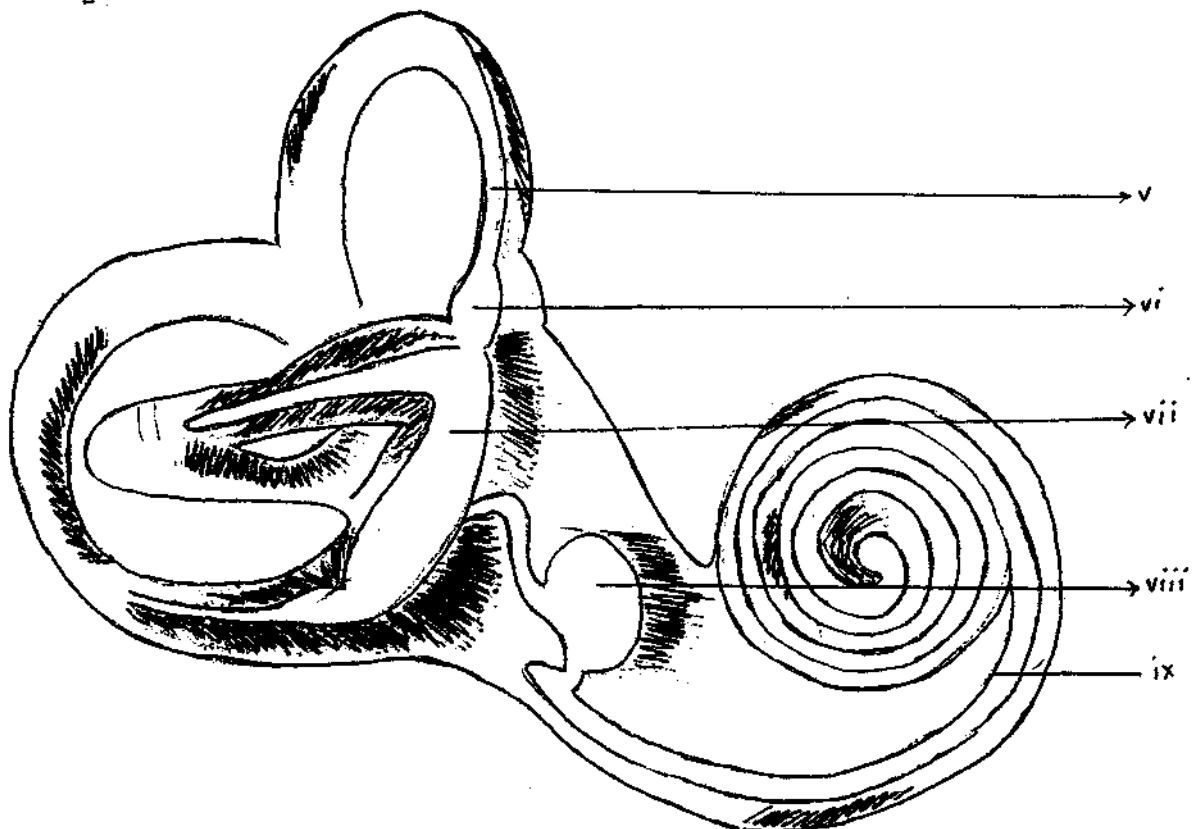
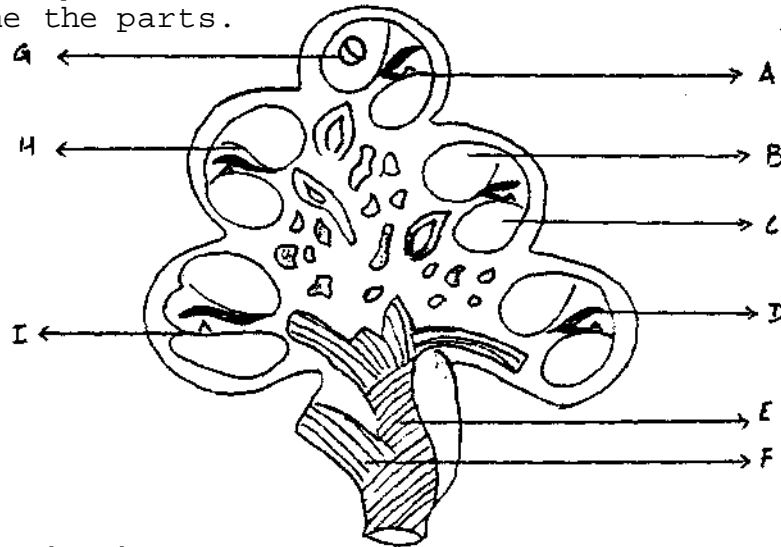

FIG. 2.



- Q.15 a) Name which section of the coclea this is.  
 b) Name the parts.



- Q.16 a.) This is the cross-section of the \_\_\_\_\_ showing the major structures of the \_\_\_\_\_.  
 b) Match the different parts with their names.

- |                          |                        |
|--------------------------|------------------------|
| 1. Spiral limbus         | 2. Stria vascularis    |
| 3. Osseous spiral lamina | 4. Inner hair cells    |
| 5. Inner sulcus cells    | 6. Arch of cortii      |
| 7. Inner phalangeal cell | 8. Basilar membrane    |
| 9. Reticular lamina      | 10. Cells of Boettcher |
| 11. Tectorial membrane   | 12. Stereo cilia       |
| 13. Outer hair cells     | 14. spiral ligament    |
| 15. Cells of Hensen      | 16. Cells of claudius  |

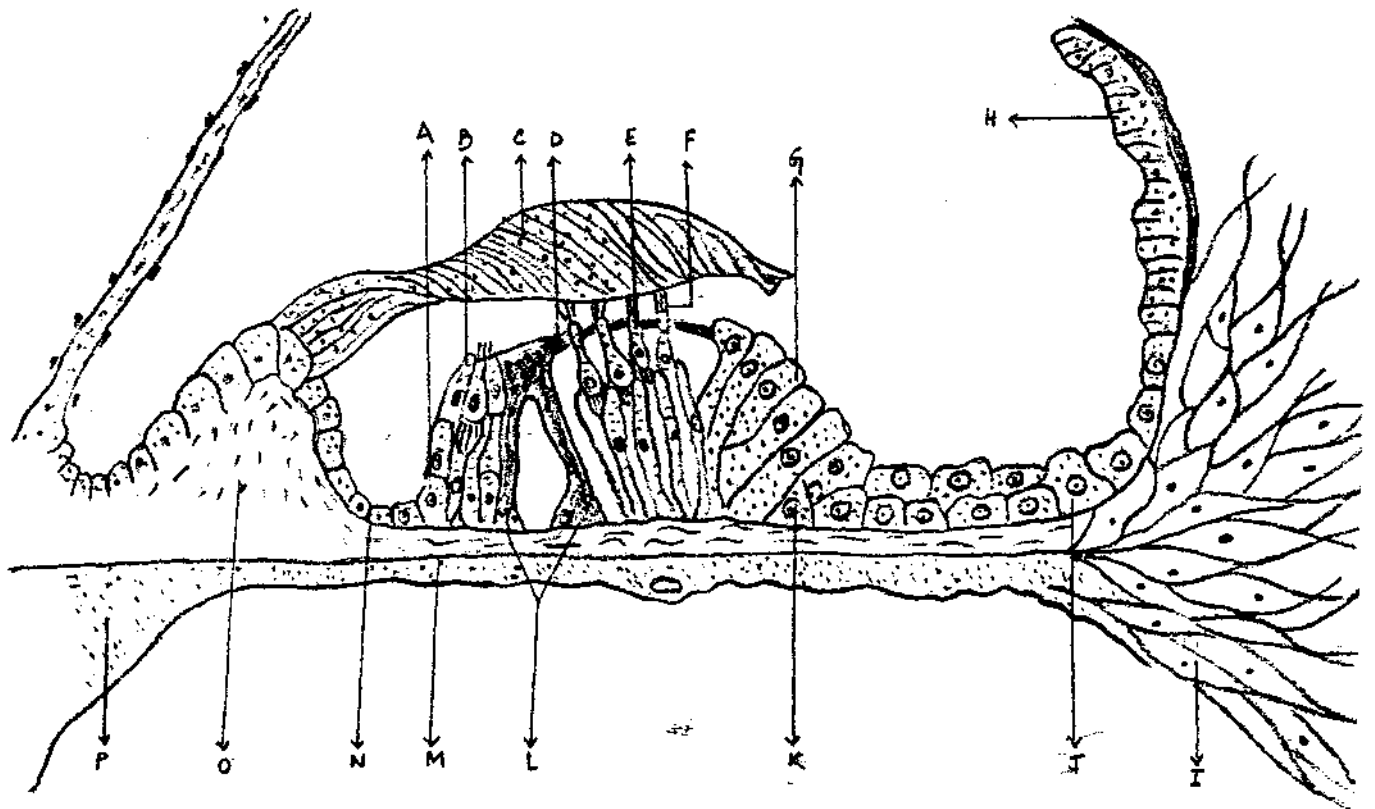

- Q.17 a) What does the diagram depict  
 b) Label the parts

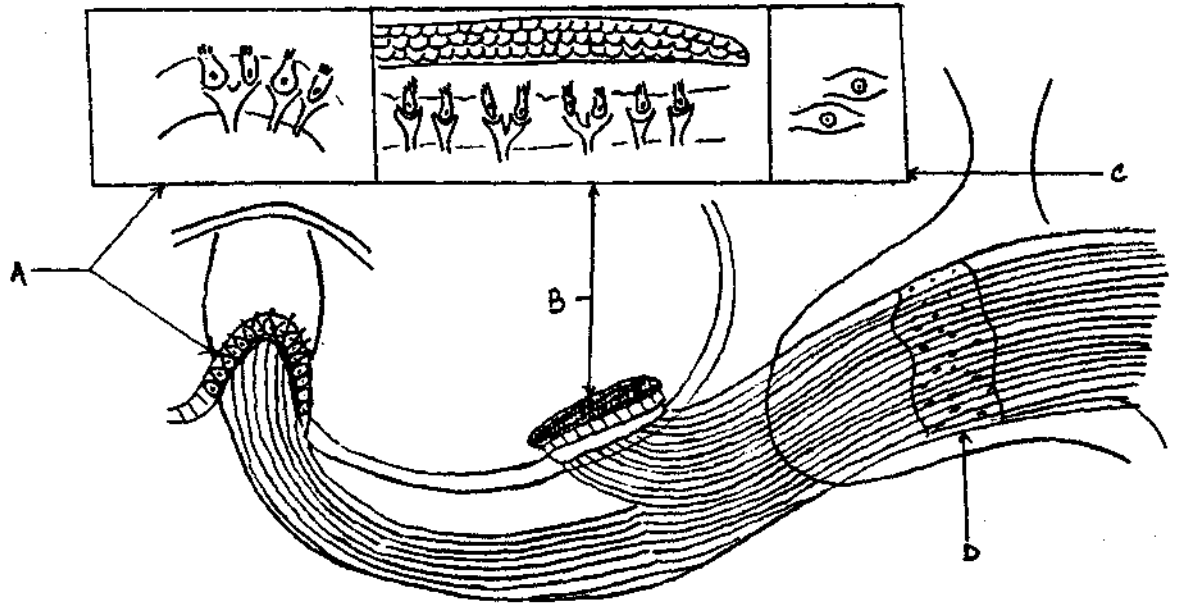

- Q.18 a) Where in your body do you find these cells ?  
 b) Label the parts.

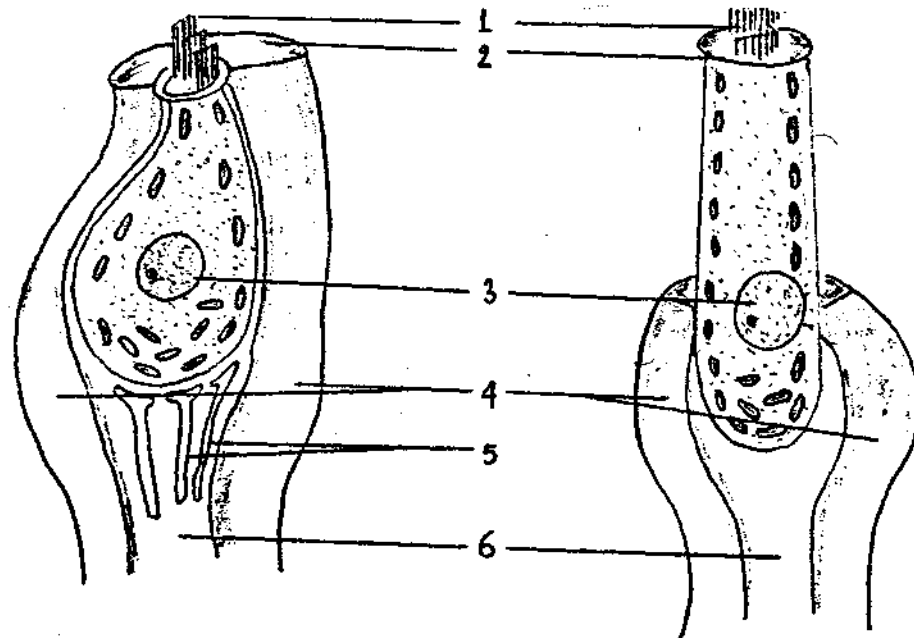

Q.19 Indicate the potentials of the shaded portions.

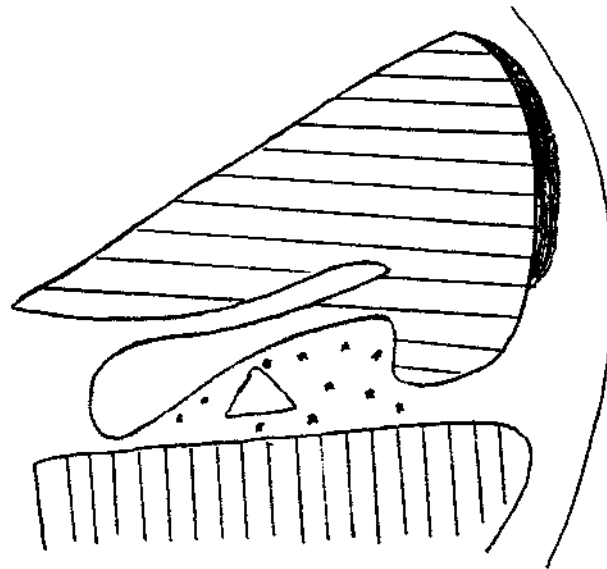

Q.20 Can you explain what this phenomenon is and when it takes place.

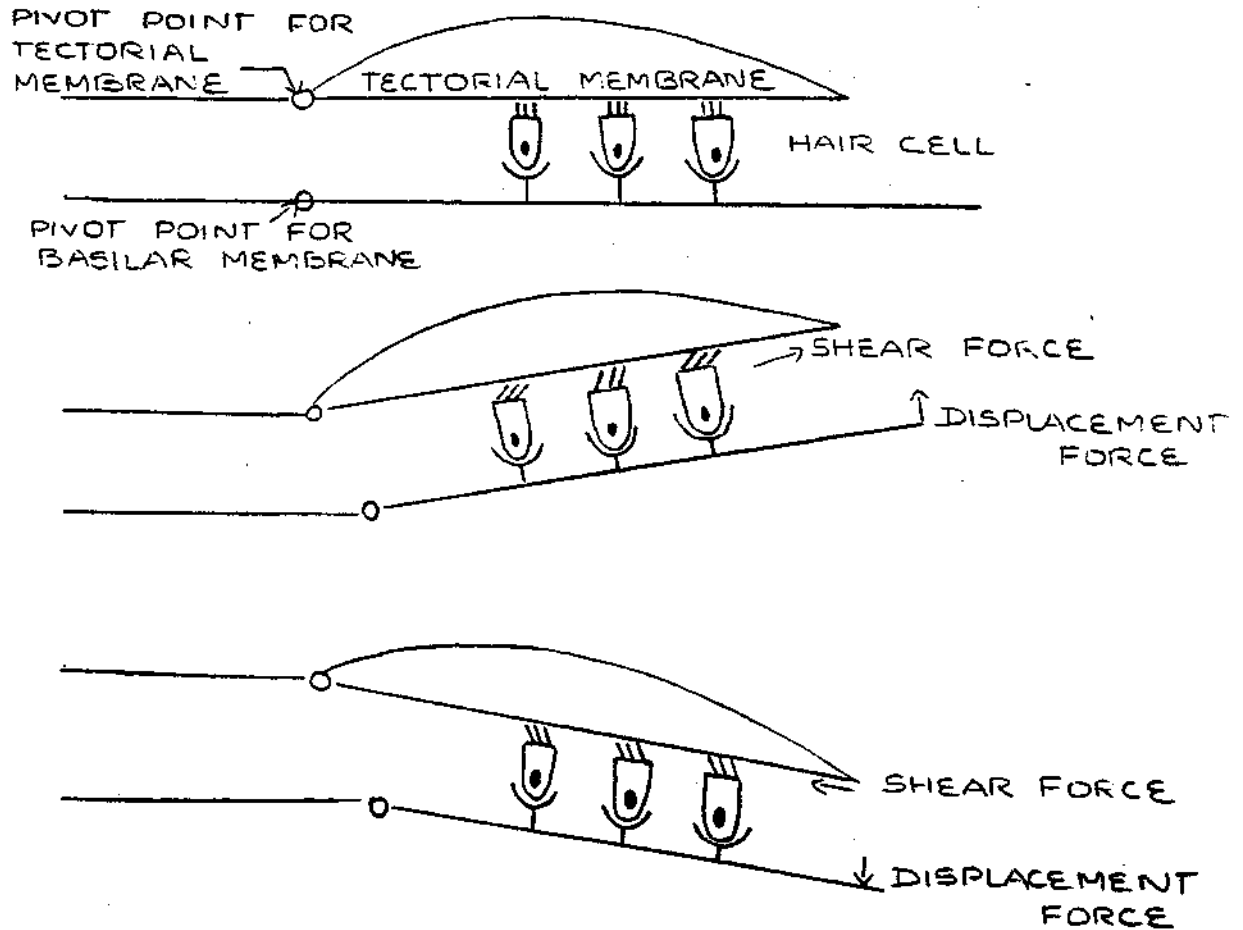



- Q.21 This no doubt looks like a collection of waves.  
a) What does it depict ?  
b) Who gave it ?

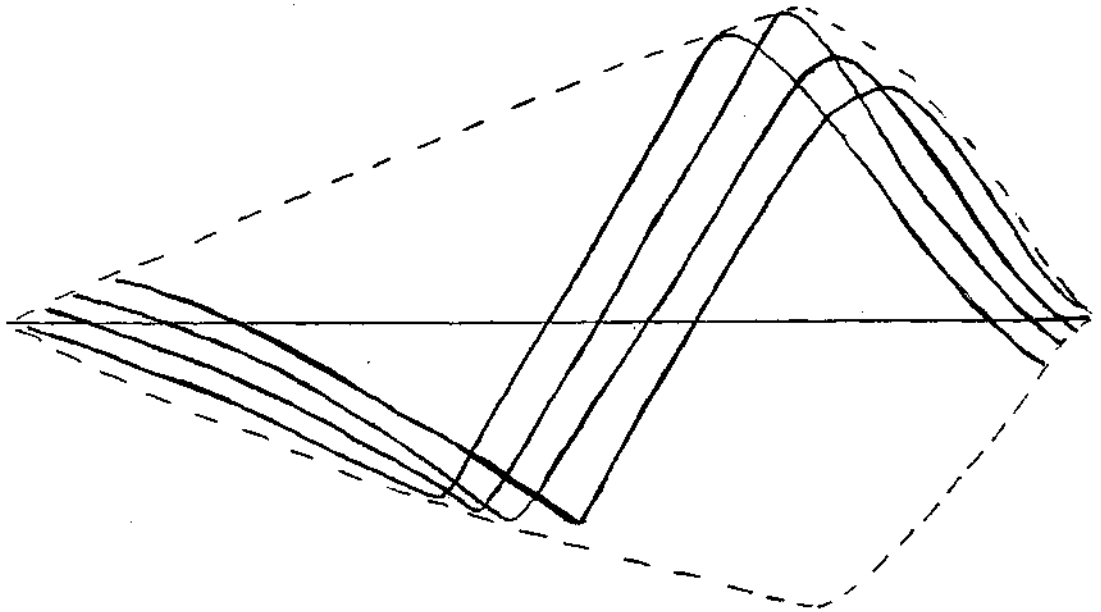

- Q.22 What type of disease does this figure show ?

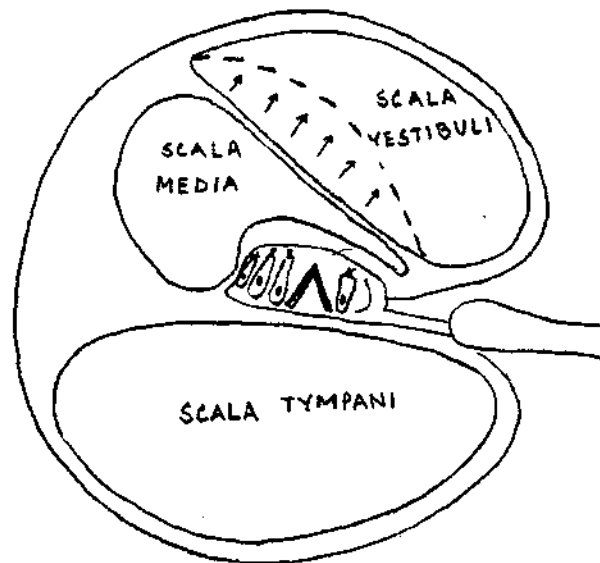

Q.23 Identify the pathology and explain.

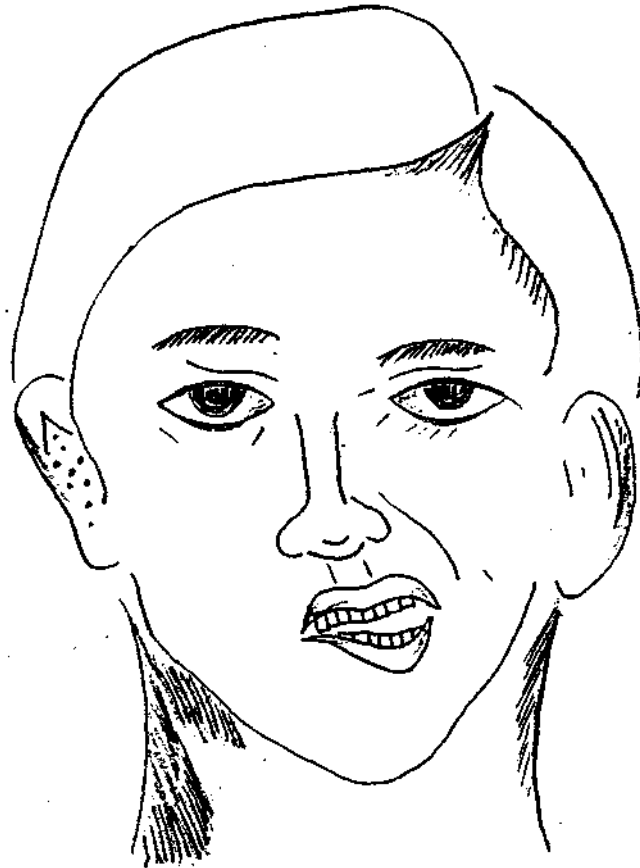

## AUDIOLOGICAL EVALUATION

Q 1. Match the following :-

AUDIOLOGICAL TECHNIQUES:

GRAPHICAL REPRESENTATIONS

1. BEKESY AUDIOMETRY

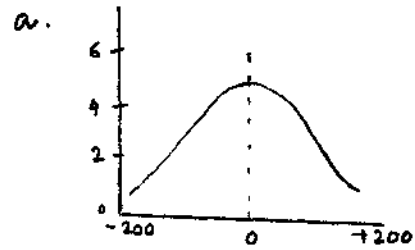

2. ABR TRACING

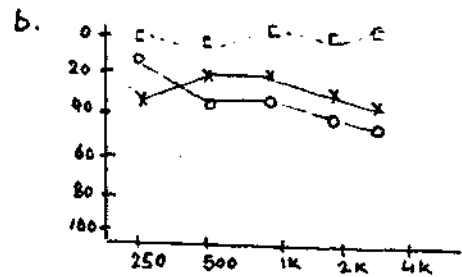

3. PURE - TONE AUDIOMETRY

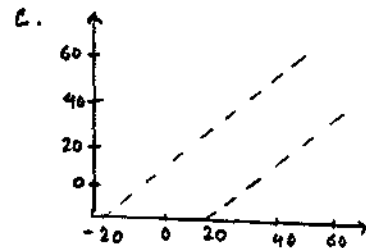

4. IMPEDENCE AUDIOMETRY

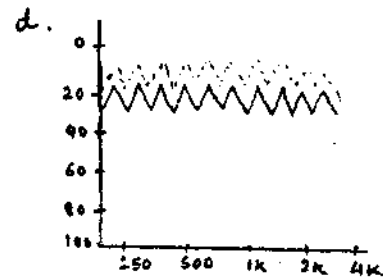



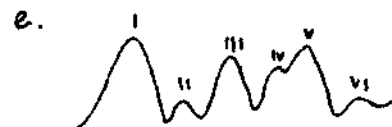











5. ABLB TESTING



Q.2. Match the following :- (according to ASHA 1990)

Key for audiogram symbols

Modality

- |     |   |                                     |
|-----|---|-------------------------------------|
| 1.  |    | a) Unmasked AC - Left.              |
| 2.  |    | b) Unmasked BC - (Mastoid)-Right.   |
| 3.  |    | z) masked BC - (forehead)-Right.    |
| 4.  |    | d) AC sound field - Left.           |
| 5.  |    | e) Masked BC (mastoid) NR Left.     |
| 6.  |    | f) Unmasked AC - Right.             |
| 7.  |    | g) Masked AC- left                  |
| 8.  |  | h) Masked AC- Left.                 |
| 9.  |  | i) Masked BC (mastoid)-Left.        |
| 10. |  | j) Masked BC (mastoid)-Right.       |
| 11. |  | k) Unmasked BC (mastoid)-Left.      |
| 12. |  | l) Unmasked BC(mastoid)-unspecified |
| 13. |  | m) Masked BC (forehead)-Left.       |
| 14. |  | n) Unmasked BC(forehead)unspecified |
| 15. |  | o) AC sound field - Right.          |

(AC-Air Conduction; BC-Bone Conduction; NR-No Response.)

- Q.3 a) What are these ?  
 b) Re-arrange the anagrams.  
 c) What otological conditions yield such types ?

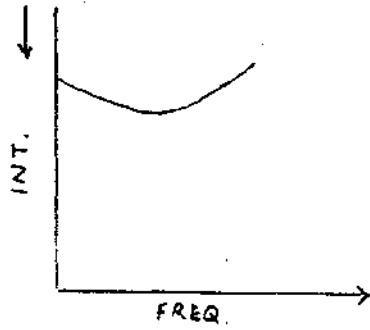

A. CRUEAS PSADEH

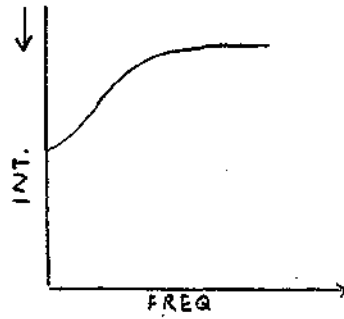

B. FITSESNFS ITLT

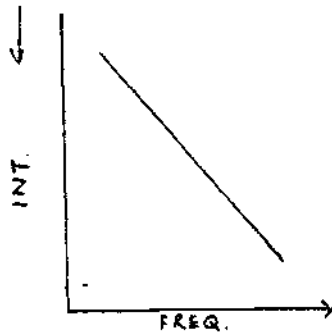

C. MSSA TITL

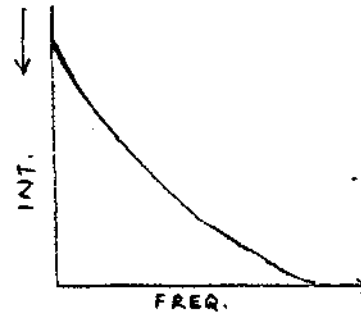

D. NRECRO



E. KIOCOE TEIB

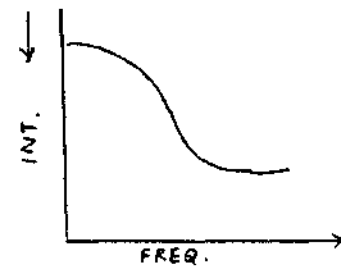

F. KIS PLOES

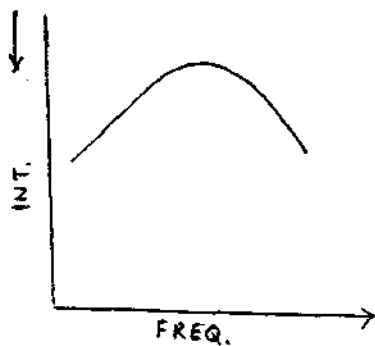

G. DEOM PDEHAS

Q.4 Identify the pathological condition based on the typical pure tone audiogram.

1

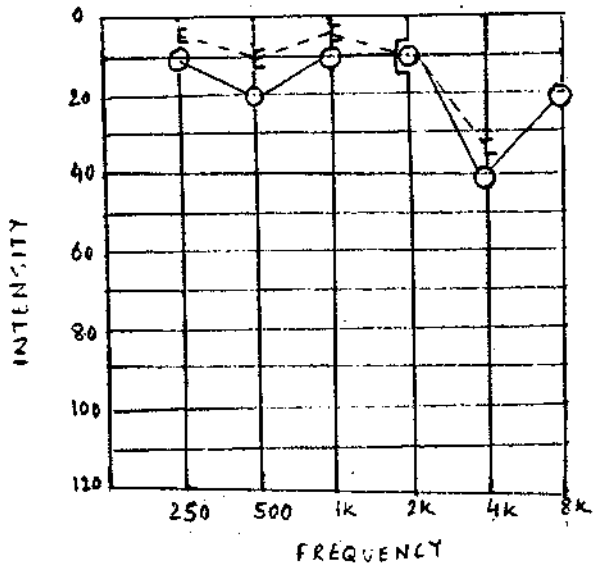

2

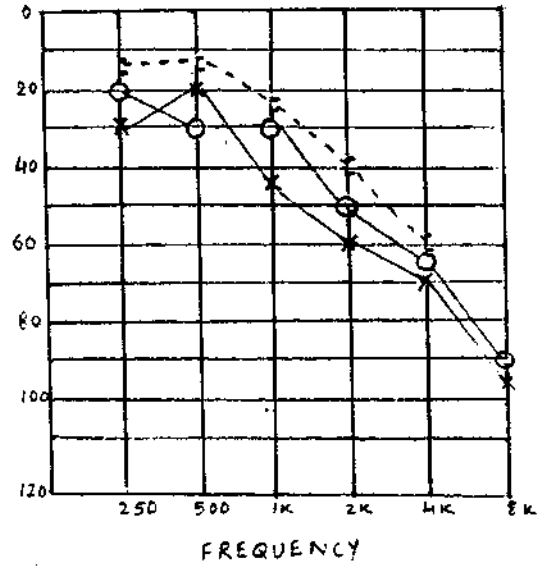

3

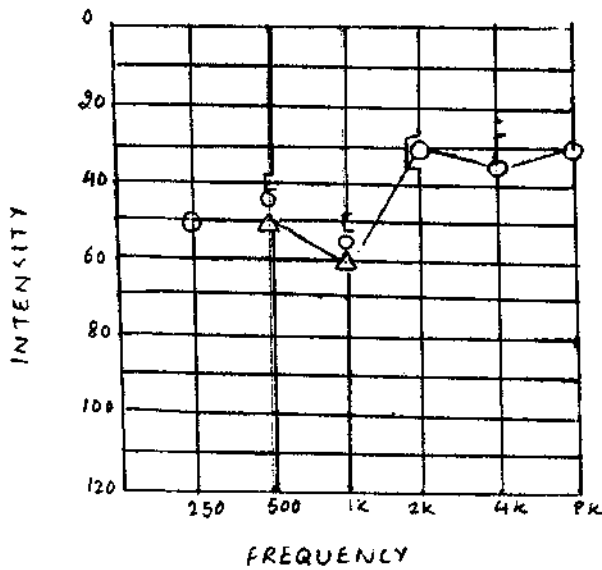

4

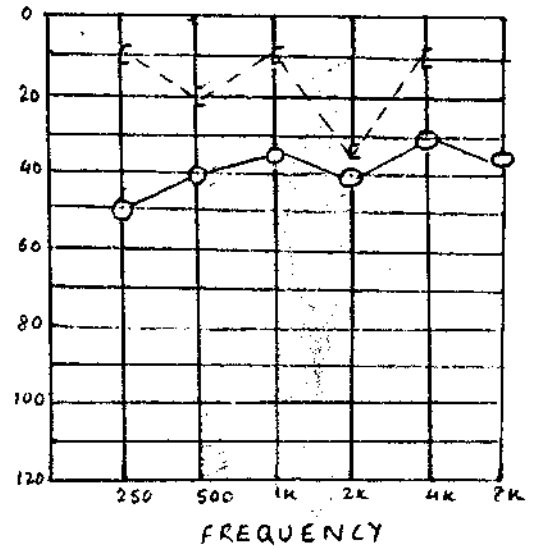

5

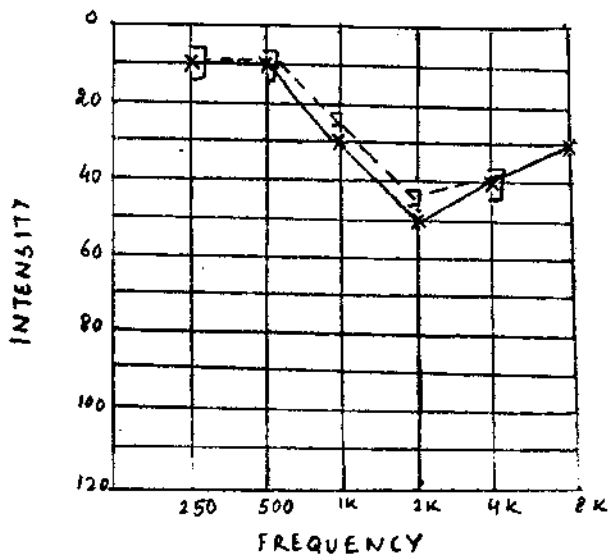

- Q.5 a) Label 'a', 'b' and 'c' on the graph,  
 b) What does the graph depict ?

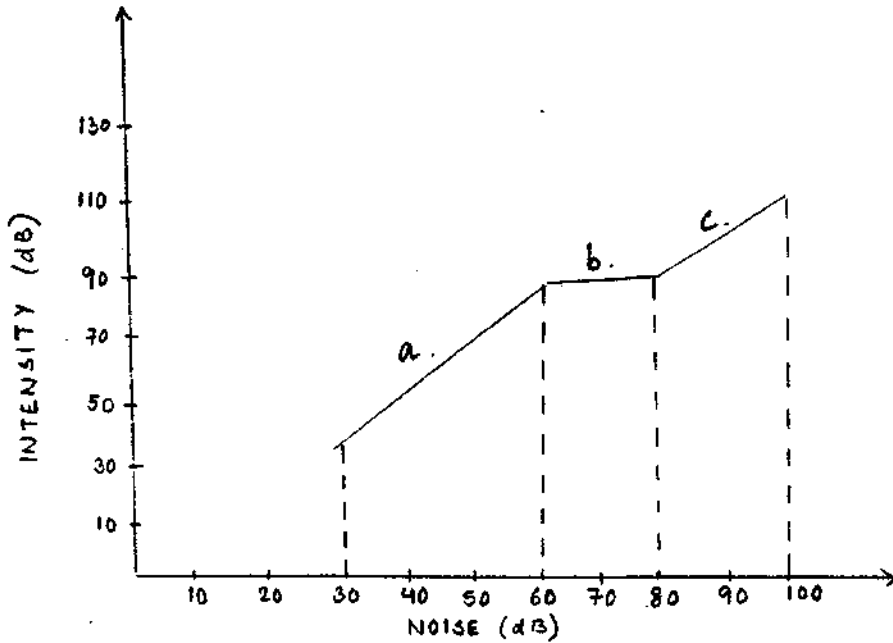

- Q.6 While doing speech audiometry on normals, what do the 3 lines a, b & c on the graph depict?

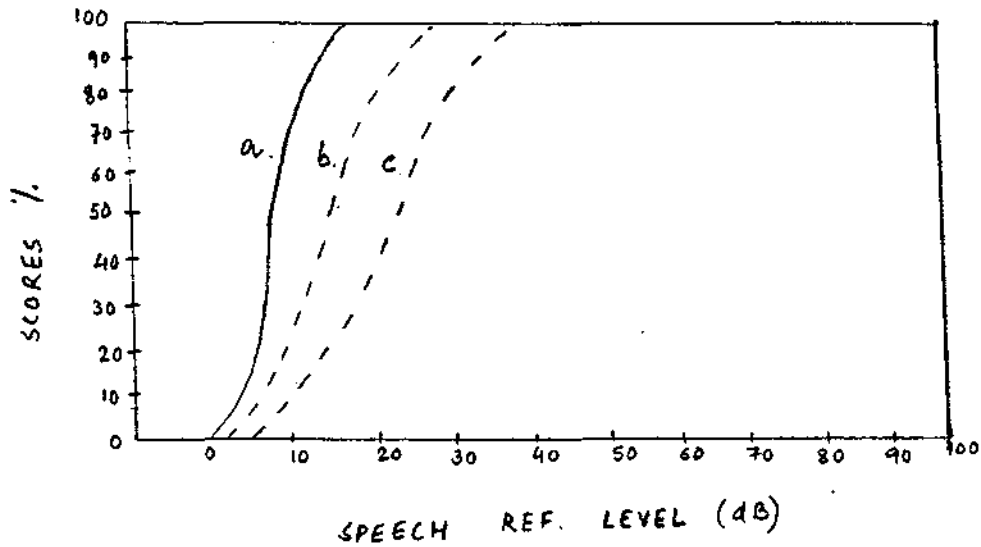

- Q.7 a) What does the graph depict ?  
 b) Label a, b, c, d & e.  
 c) What do lines 1 & 2 depict ?

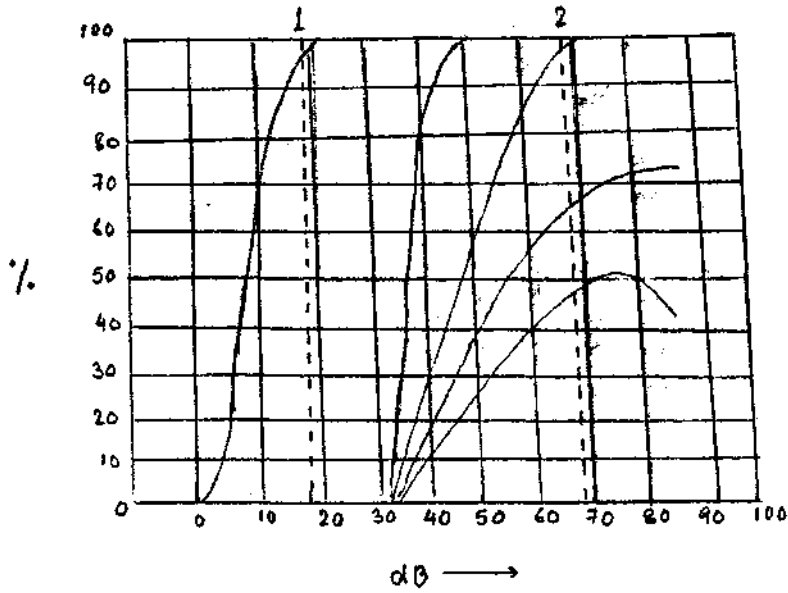

- Q.8 a) What does the graph depict ?  
 b) Label A, B, C & D.

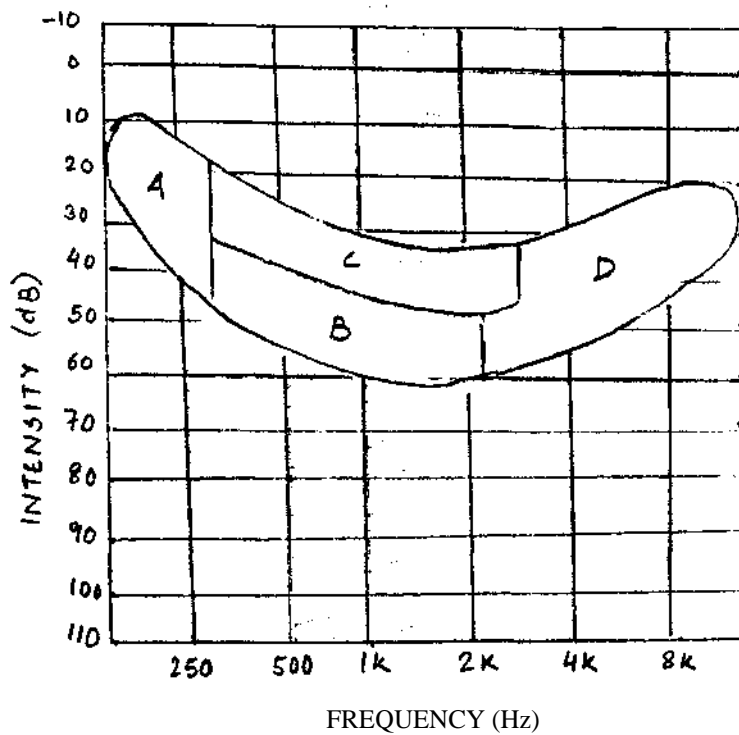



- Q.9 a) Name the different types of tympanograms.  
 b) State the pressure - compliance functions.  
 c) State one pathological condition where it is usually seen.

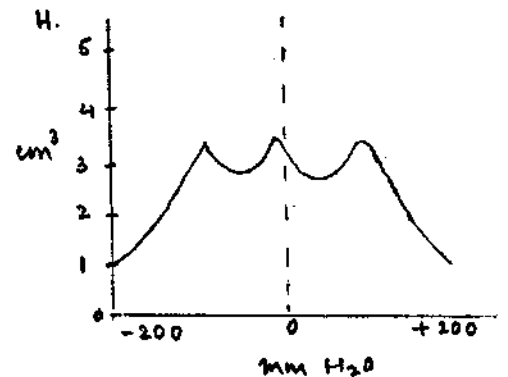
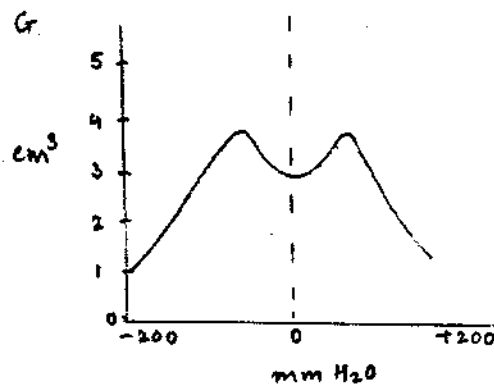
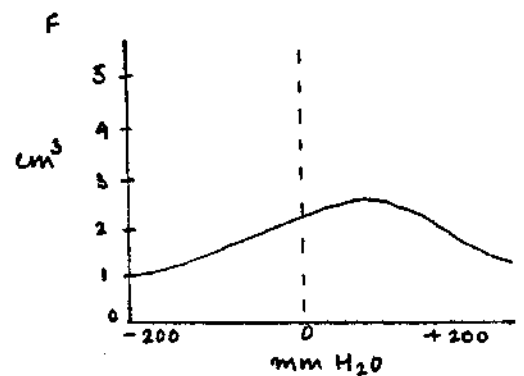
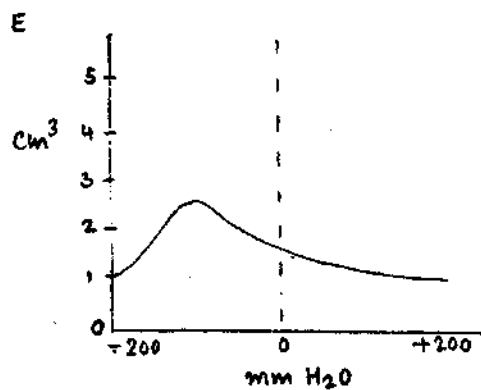
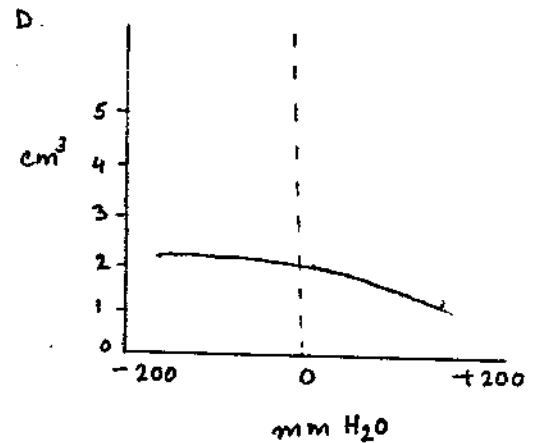
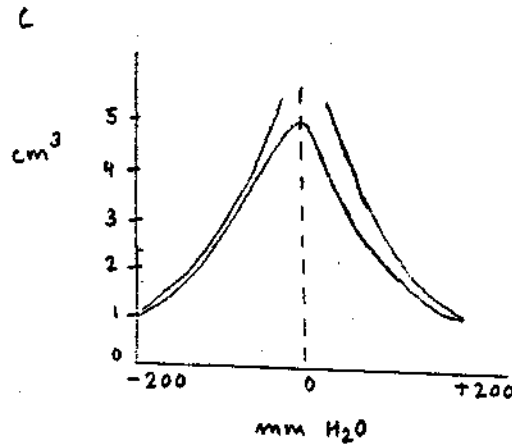
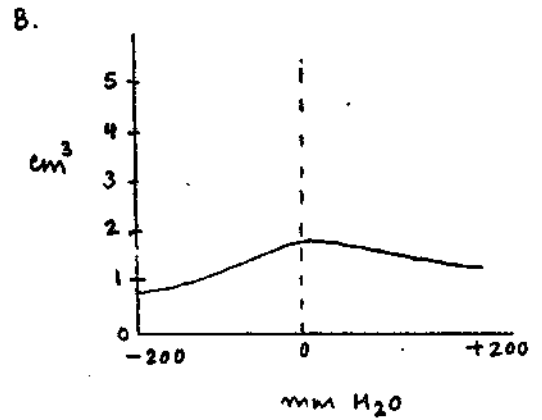
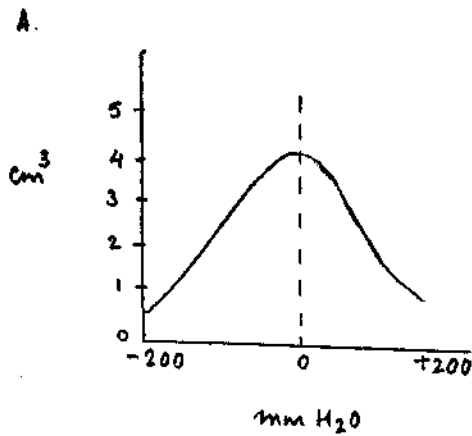

- Q.10 a) This figure represents the \_\_\_\_\_  
b) Label A - F  
c) Mark X's for where the lesions could be expected for  
i) Facial palsy.  
ii) Brain stem lesion  
iii) Extra axial lesion

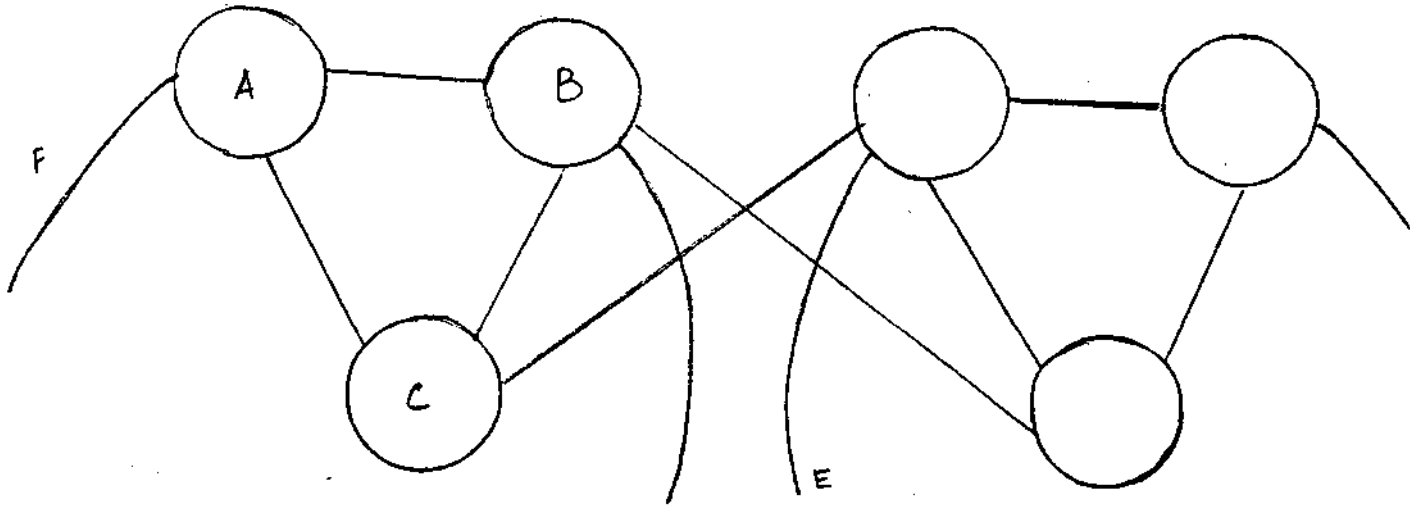

Q.11 Choose the correct one--

(1) Using which instrument do you get patterns shown below ?

- 1) Impedance audiometer.
- 2) Bekesy audiometer.
- 3) Pure tone audiometer.

(2) Whose name is associated with these boxes ?

- 1) Carhart
- 2) Jerger
- 3) Katz

(3) i) Diagonal pattern is seen in

R L



- 1) Profound Sensory Neural hearing loss
- 2) Retrocochlear pathology
- 3) Both of the above.

ii) Horizontal pattern is seen in

R L



- 1) Retrocochlear pathology
- 2) Conductive hearing loss
- 3) None of the above

iii) Vertical pattern is seen in

R L



- 1) Moderate conductive hearing loss.
- 2) Unilateral facial palsy.
- 3) Both of the above.

iv) Inverted L pattern is seen in

R L



- 1) Brain stem disorder
- 2) Severe conductive hearing loss
- 3) None

v) Unibox pattern is seen in

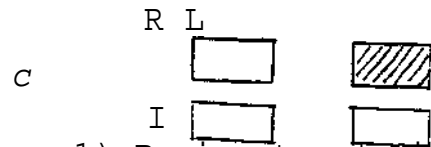

- 1) Brain stem lesion
- 2) Sensory Neural hearing loss
- 3) None

vi) Four square pattern is seen in

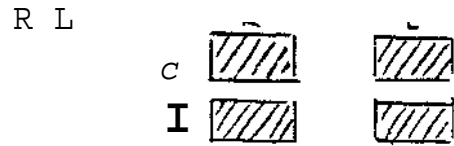

- 1) Bilateral severe hearing loss
- 2) Severe Sensory Neural hearing loss
- 3) Both

- Q.12 a) These are used for the evaluation of \_\_\_\_\_  
 b) Label tests A, B in both the graphs.

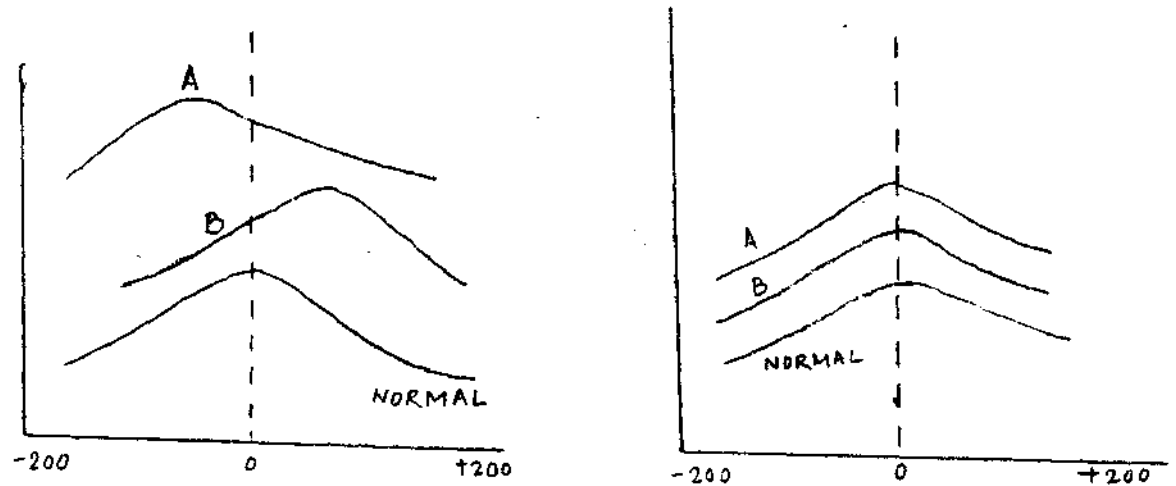

- Q.13 a) What does this diagram depict ?  
 b) Label A & B.

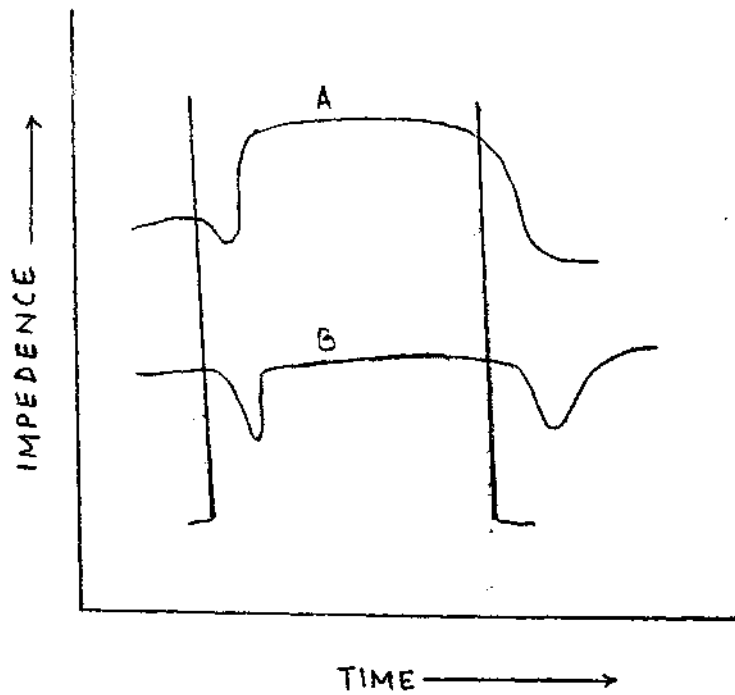

- Q.14 a) The diagram represents \_\_\_\_\_ test.  
 b) What kind of disorders is it used to detect and how ?

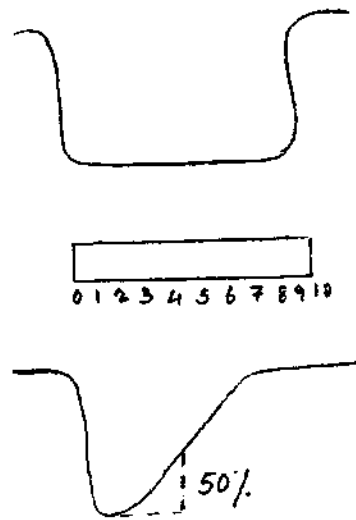

Q.15 DESCRIBE & DIAGNOSE

- a) HISTORY --> 9 yr old who failed in school hearing screening

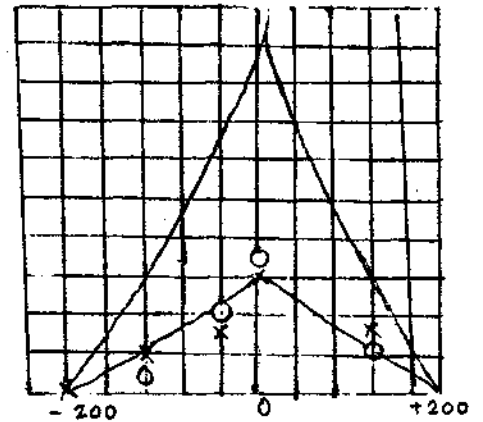
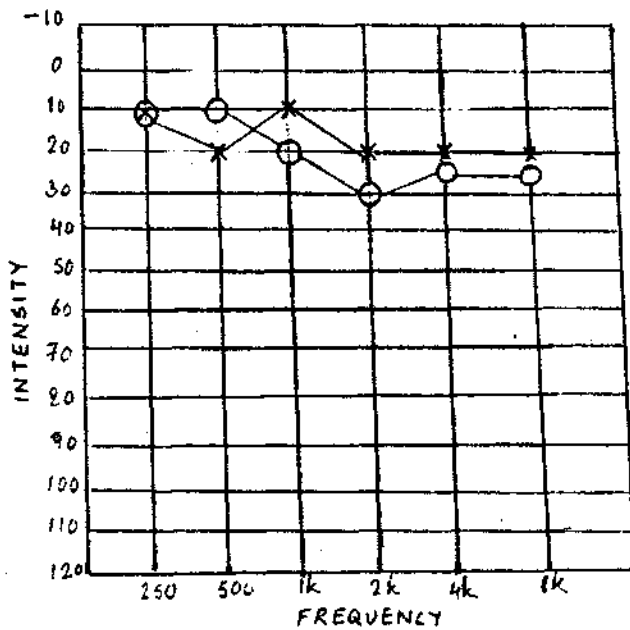

	R	L
PTA	10	7
SRT	10	10
PB-MAX	100%	100%

STAPEDIUS REFLEX THRESHOLD

	IPSI	500	1K	2K	4K	CONTRA	500	1K	2K
R		80	80	85	80		NR	NR	NR
L		NR	NR	NR	NR		75	75	80

b) History - failed in school screening left ear pain  
normal ENT

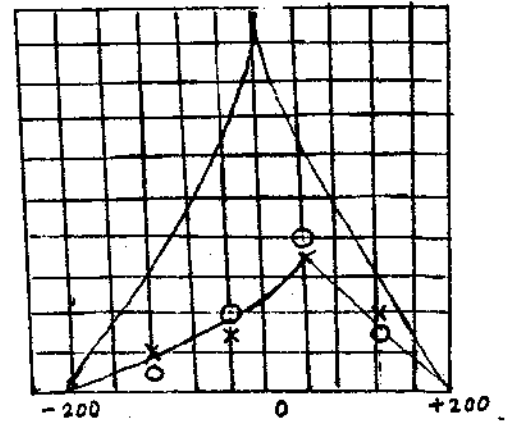
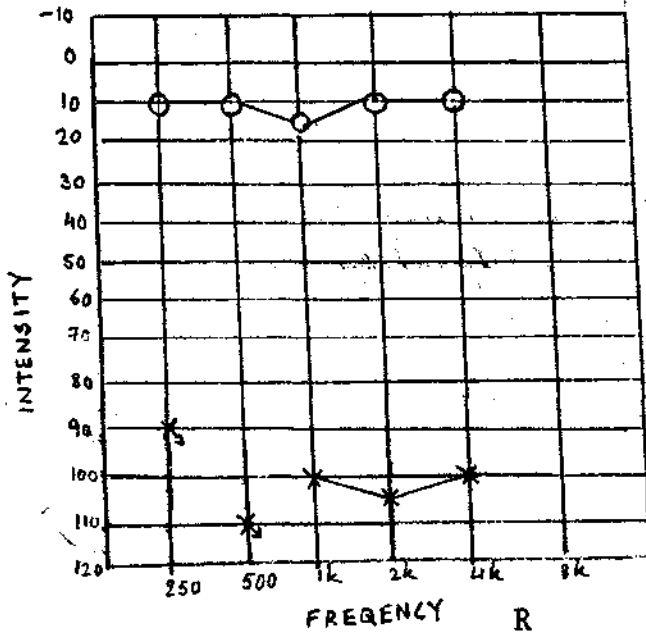

SRT	10	40
PB-MAX	1007,	96%

**CONTRALATERAL REFLEX**

	500	1K	2K	4K
R	75	80	80	85
L	80	80	85	80

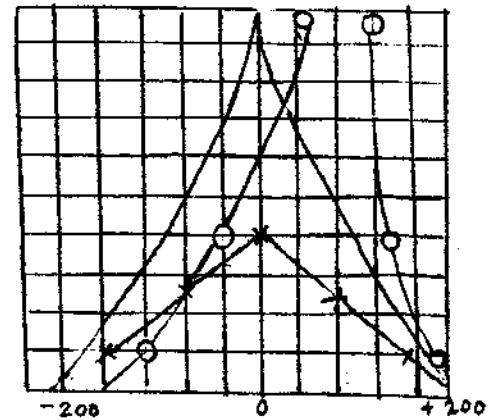
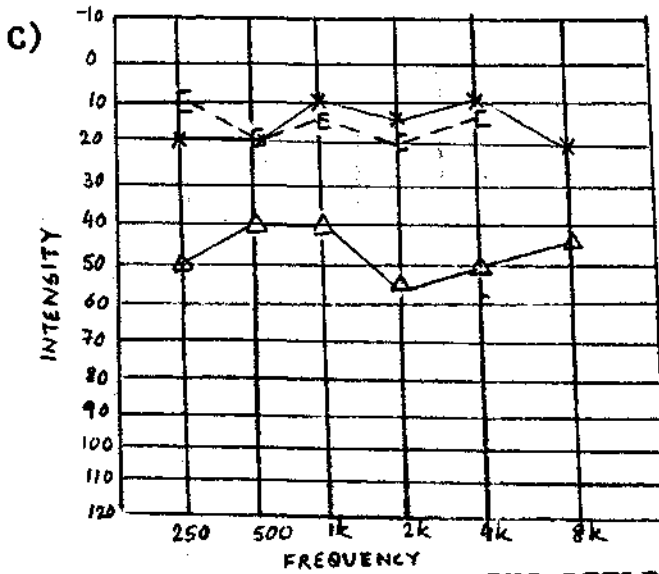

**STAPEDIUS REFLEX THRESHOLD**

	500	1K	2K
R	110	110	110
L	95	85	90

- Q.16 a) What are these called ?  
 b) These are plotted while doing \_\_\_\_\_ graphs.  
 c) Arrange these to match their corresponding graphs.

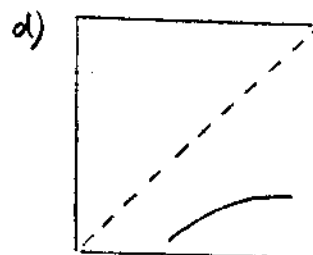
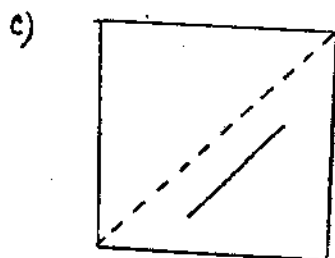
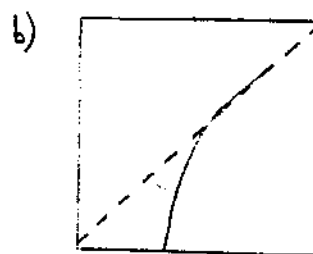
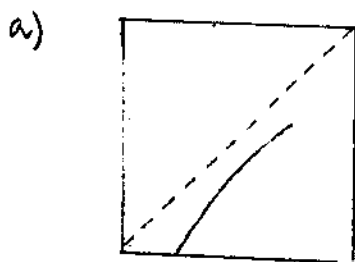
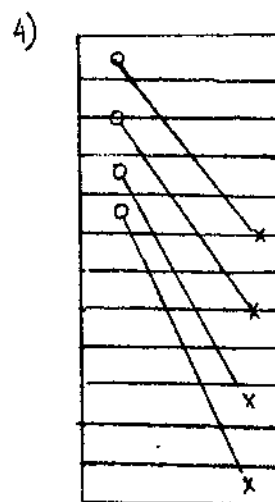
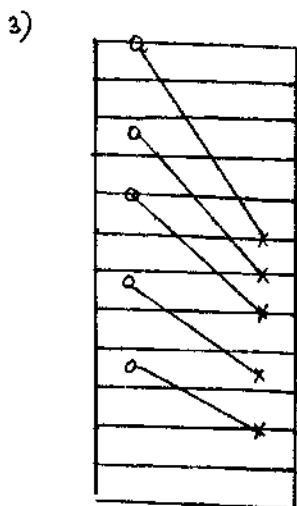
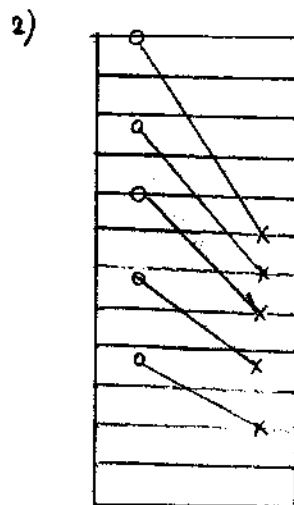
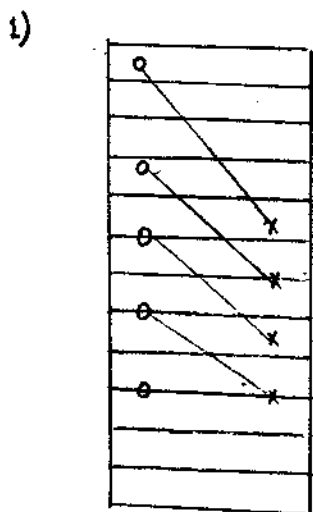



- Q.17 a) These traces are seen in \_\_\_\_\_ audiometry.  
 b) Name the different types  
 c) In which conditions are these seen ?

1.

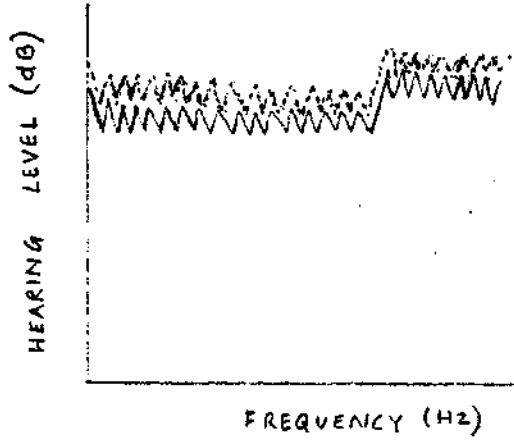

2.

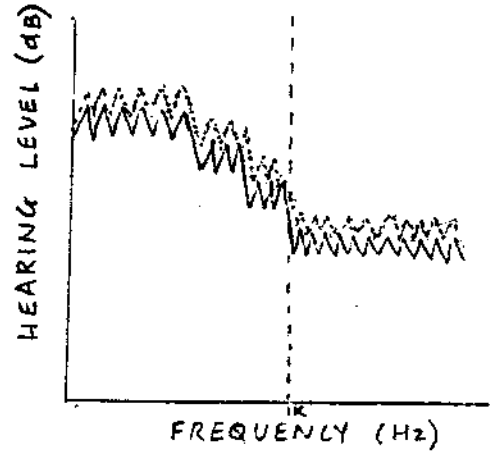

3.

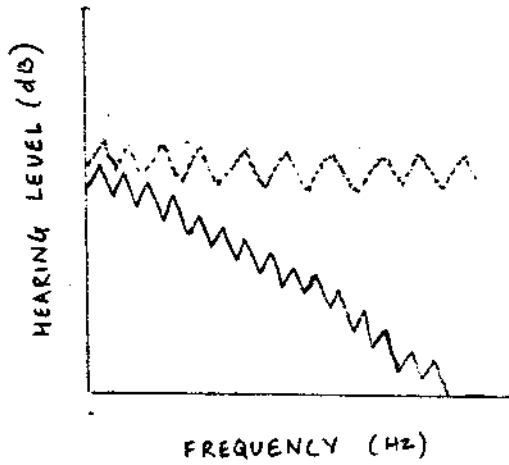

4.

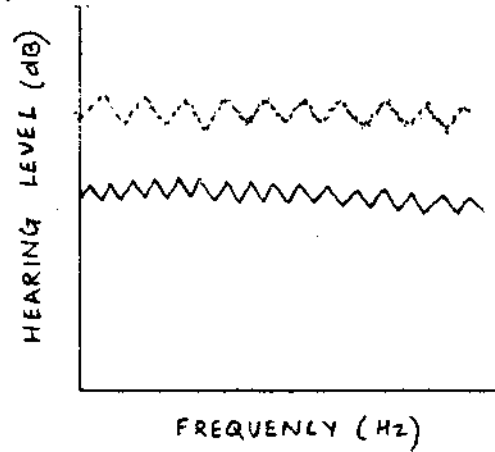

5.

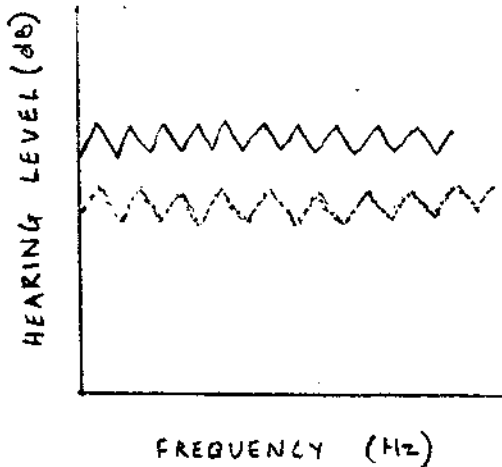

- Q.18 a) This is a test for the detection of \_\_\_\_\_  
(N T L C E R A T Y A U D O I R T F D Y I O U S N N)  
b) This is a typical example of \_\_\_\_\_

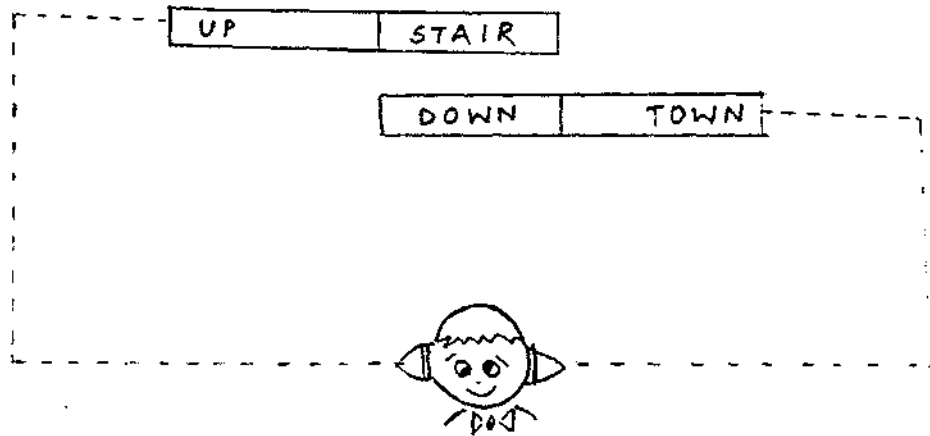







- Q.19 a) This is a composite \_\_\_\_\_  
b) Mark the peaks and valleys.  
c) Divide the wave into  
> Brain stem response  
> Late response  
> Middle response



Q.20 Match the following--

- Ages
- 1) 1 year
  - 2) 3 months
  - 3) Adult
  - 4) Newborn
  - 5) 6 weeks
  - 6) 6 Months

- ABR TRACES
- a) 
  - b) 
  - c) 
  - d) 
  - e) 
  - f) 

- Q.21 a) This is a typical /- AI-/--E-/-E-0-E/.  
 b) Label the X and Y axis  
 c) Mark the visible peaks in each waveform.

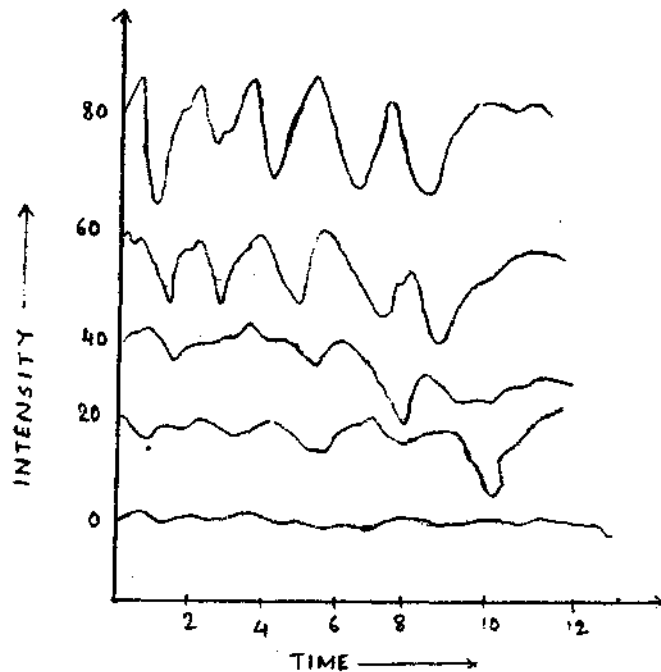

Q.22 Spot the different waveform of these auditory evoked potentials.

- Compound action potential (AP)
- Brainstem auditory evoked potentials
- Slow negative 10 (SN<sub>10</sub>)
- Frequency following response (FFR)
- Middle latency response (MLR)
- Slow vertex response (SVR)
- P-300
- Contingent negative variation (CNV)

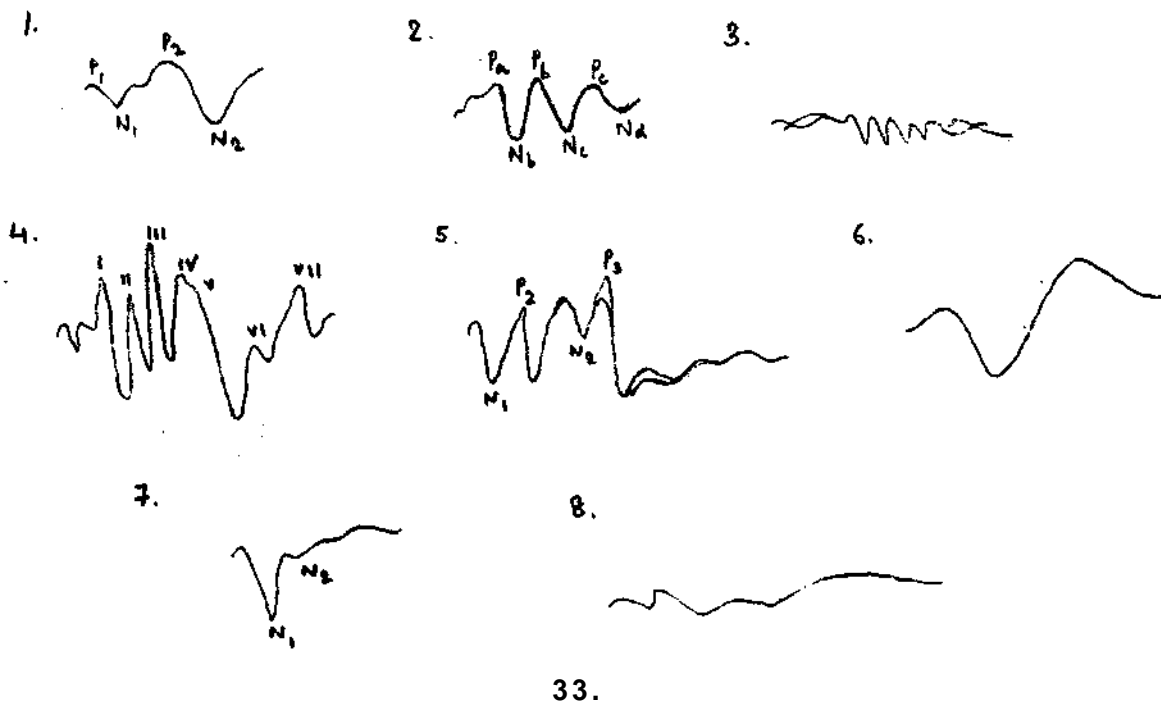

Q.23 DIAGNOSE

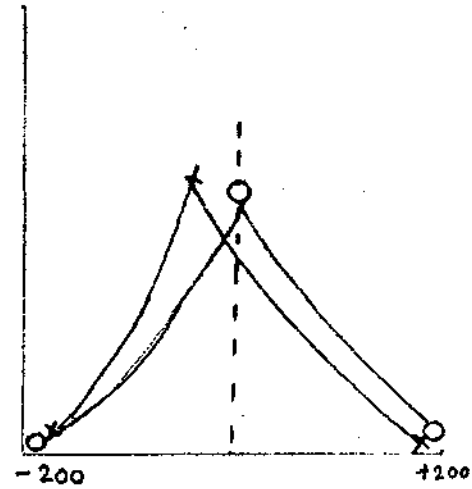
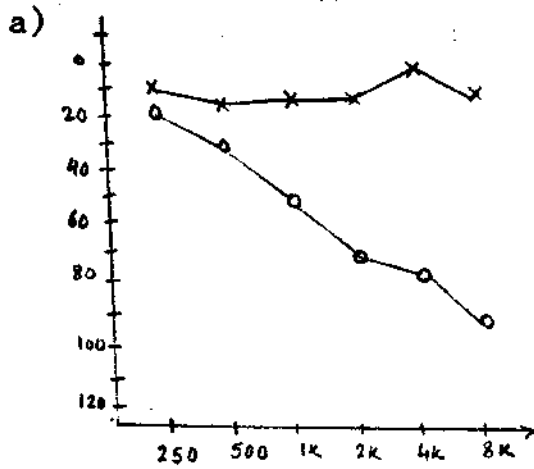

LATENCY-INTENSITY  
FUNCTION

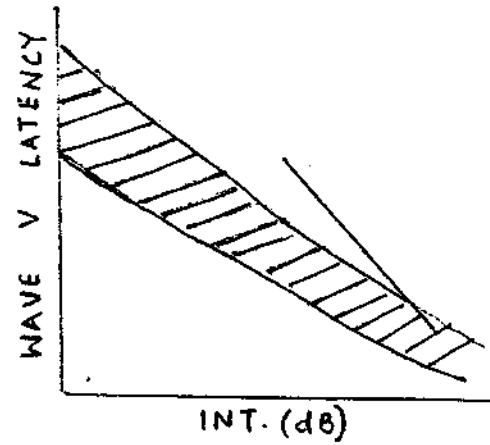
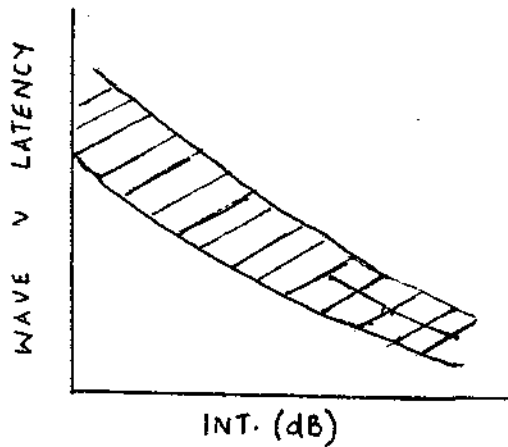

ABLB

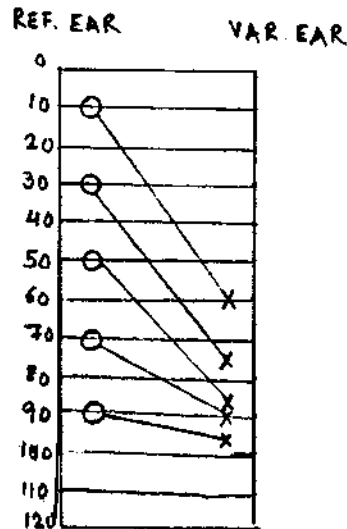

CARHART'S TONE DECAY

	500	1K	2K
R	0	0	0
L	0	0	0

SISI

R - (2k) % CORRECT 35%  
L - % CORRECT 95%

(PRESENTATION LEVEL - 20dB SL)

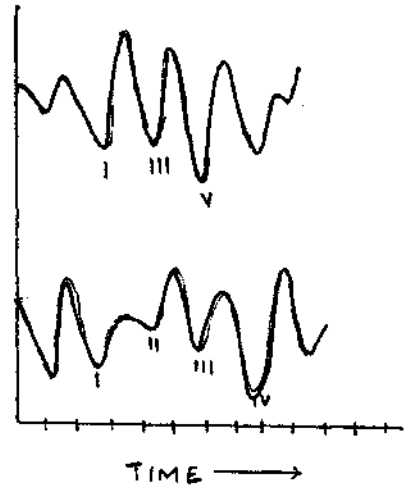
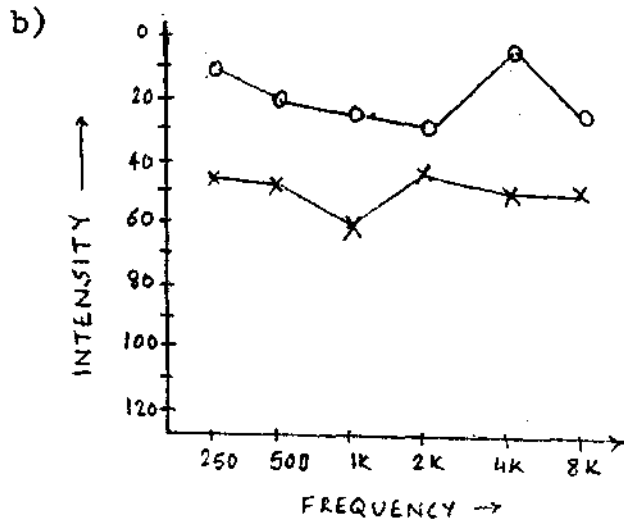

	R	L
PTA	8dB	40dB
SRT	12dB	40dB
PB-MAX	96%	76%

Q.24 This is a waveform of a \_\_\_\_\_  
from a normal hearing young adult.

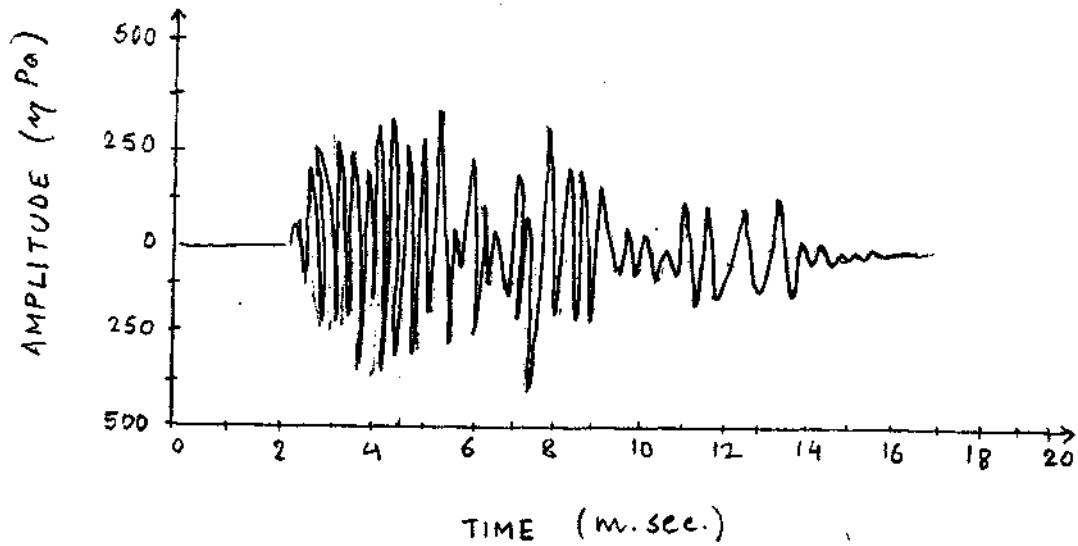

INSTRUMENTATION

- Q. 1 a) Identify these block diagrams of instruments used by an audiologist  
 b) Label the parts A - M

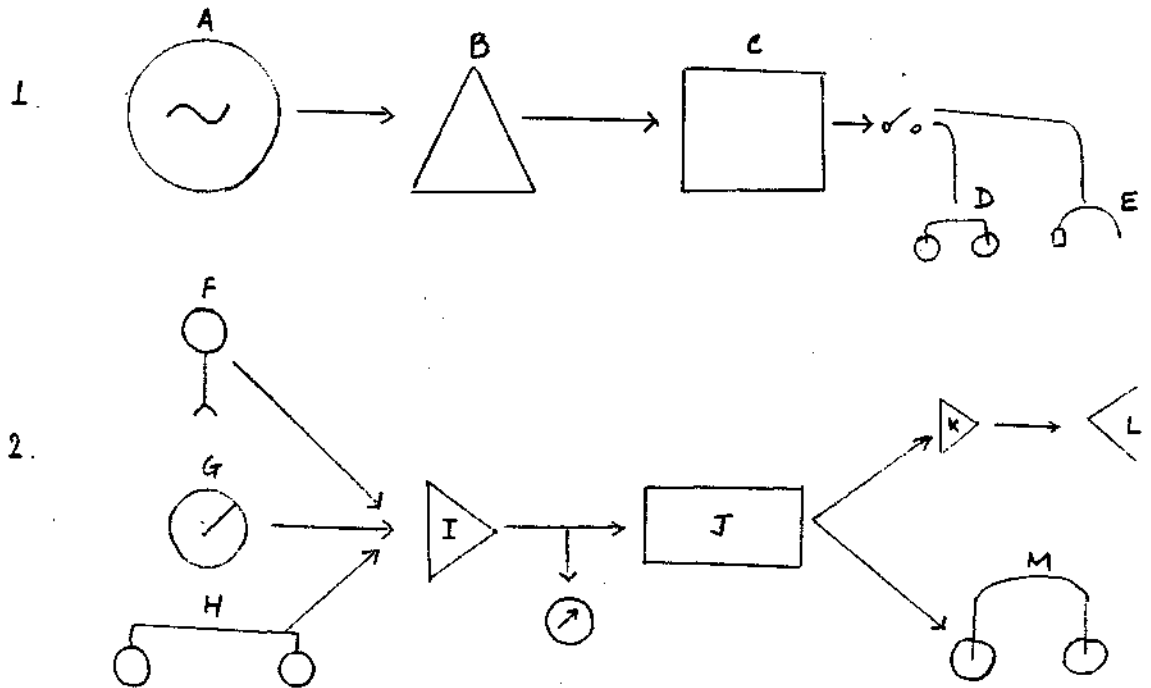

- Q. 2 Can you identify what parts make an electret microphone?  
 Label from 1 - 6

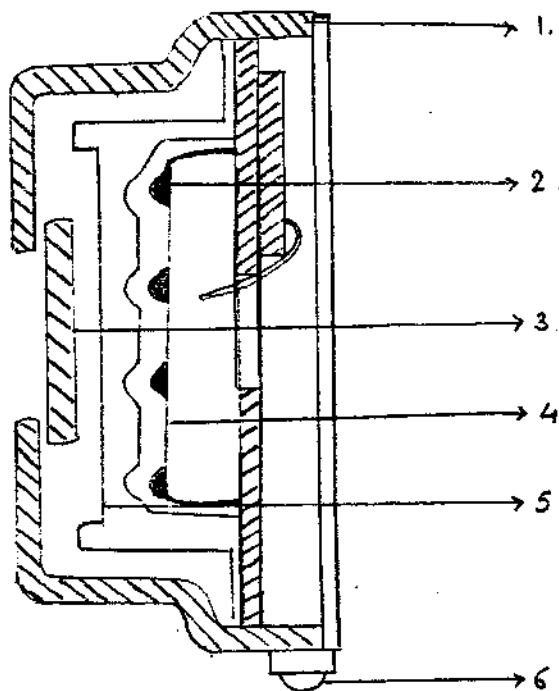

- Q. 3 a) Identify this instruments.  
b) They are all used to test a particular group  
Name the population.

a.

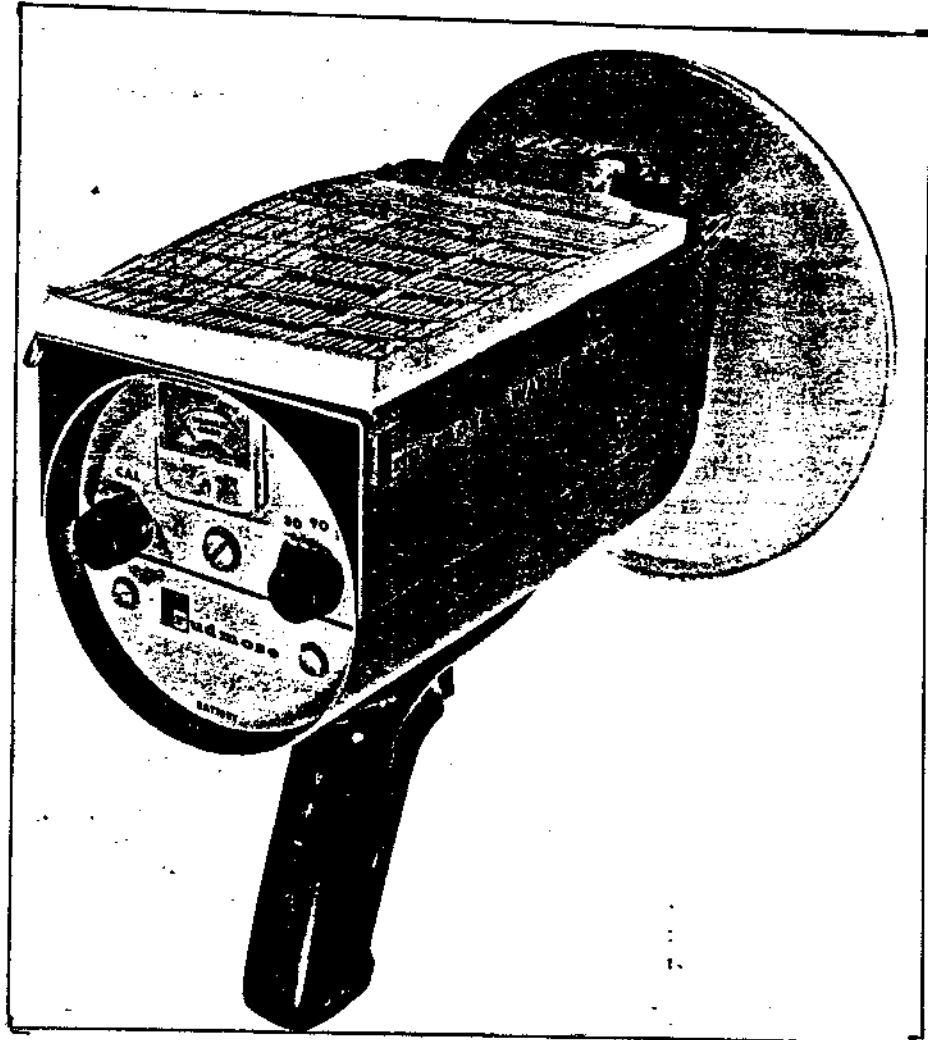

b.

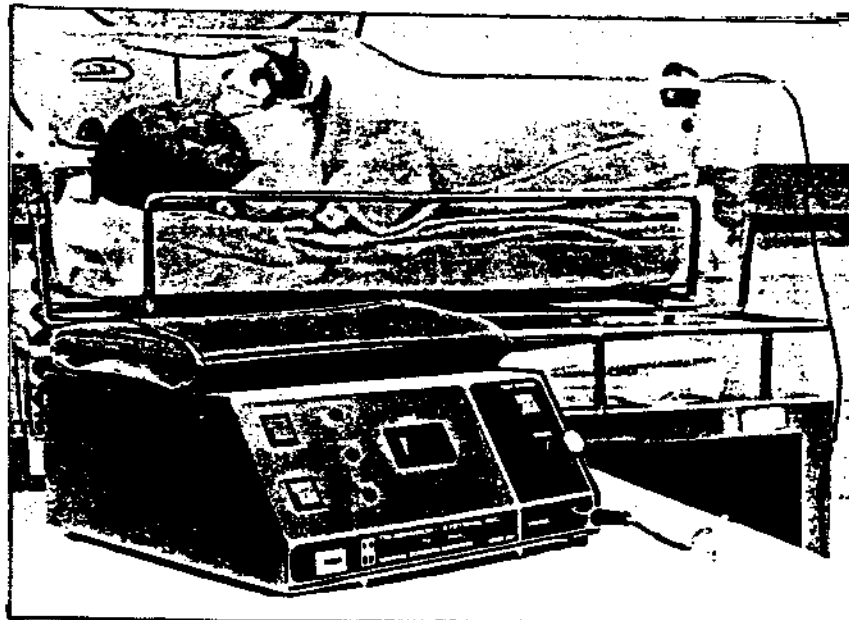



Q. 4 Identify and label.

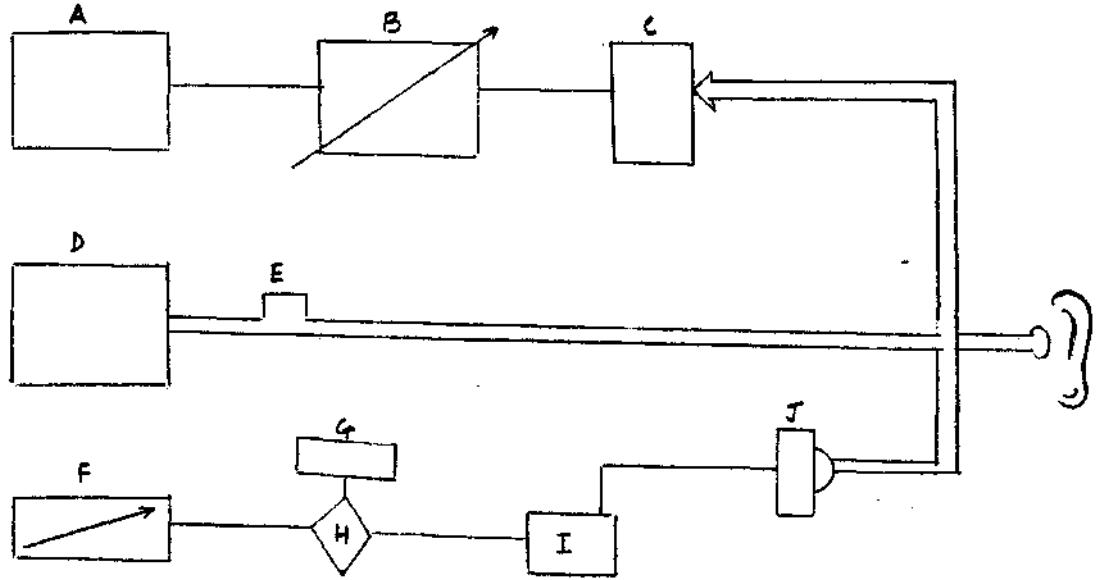

Q. 5 Name the 3 channels of the ear probe in an immittance meter.

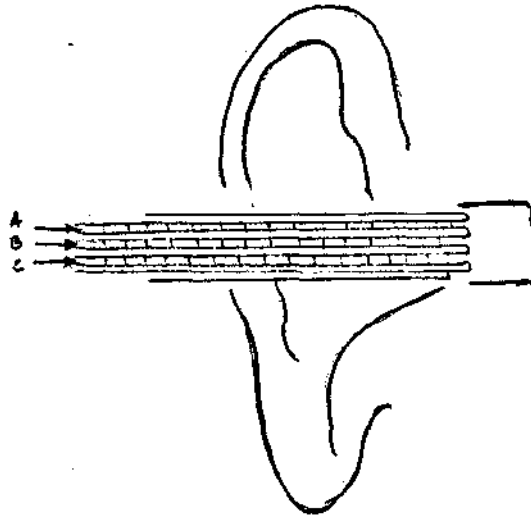

- Q. 6 a) This is a schematic of a \_\_\_\_\_ instrument.  
 b) What are the functions of A, B, & C.

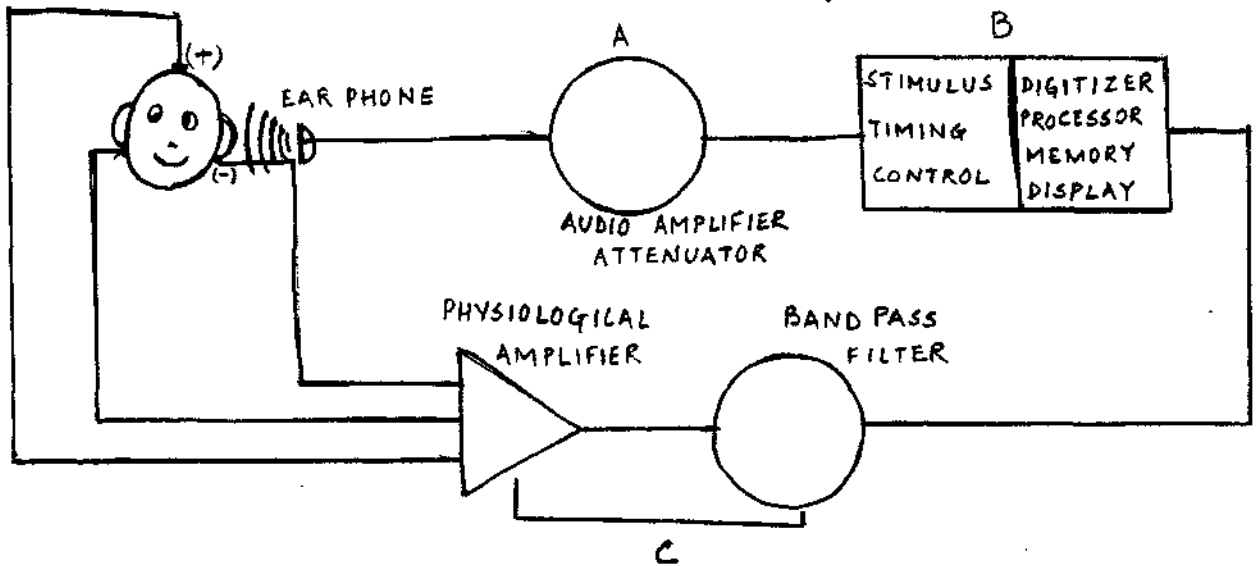

- Q. 7 a) Fig-1 & Fig-2 are used for the measurement of \_\_\_\_\_  
 b) Label the boxes in both the schematic diagrams  
 c) Differentiate Fig-1 and Fig-2 in terms of their purpose of measurement.

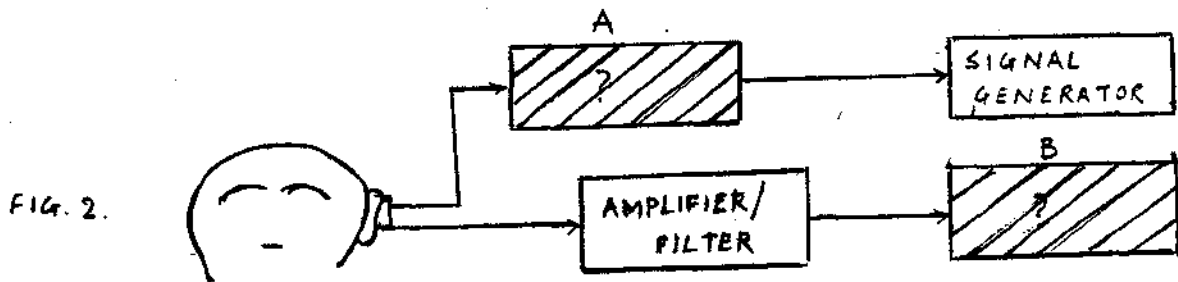
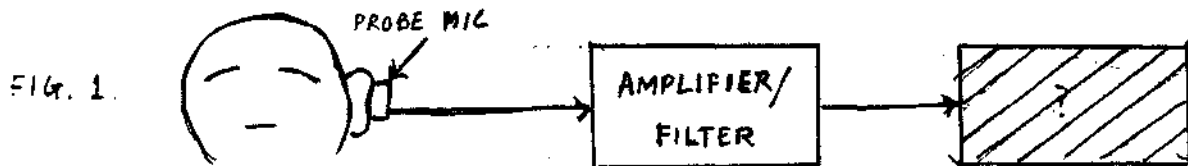

- Q. 8 a) Identify Fig-1 and Fig-2  
 b) When is Fig-2 used along with Fig-1.  
 c) Label Fig-1.

FIG. 1.

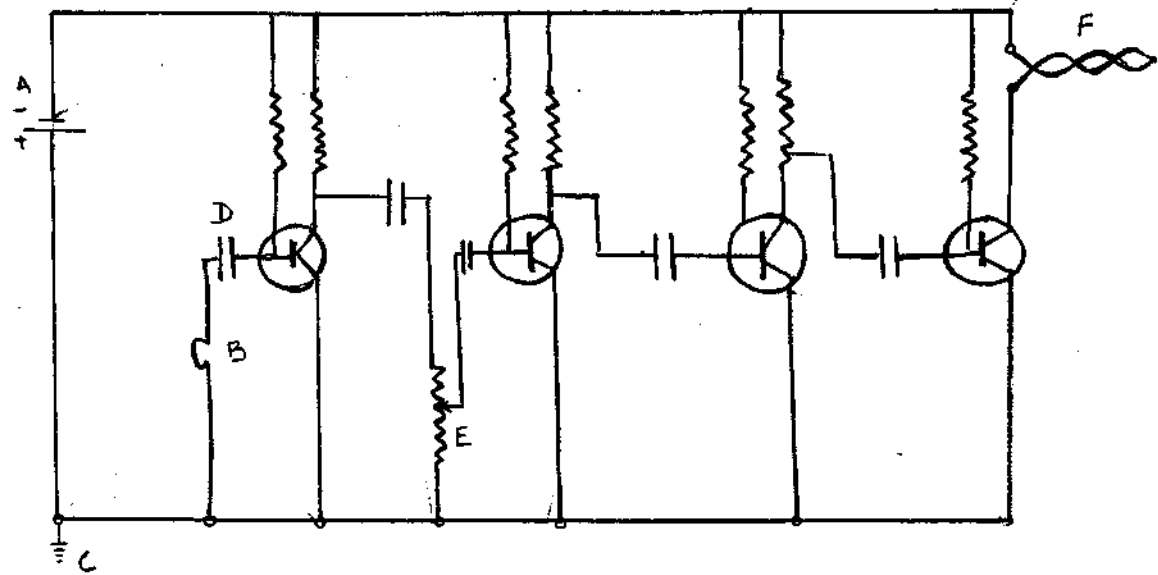
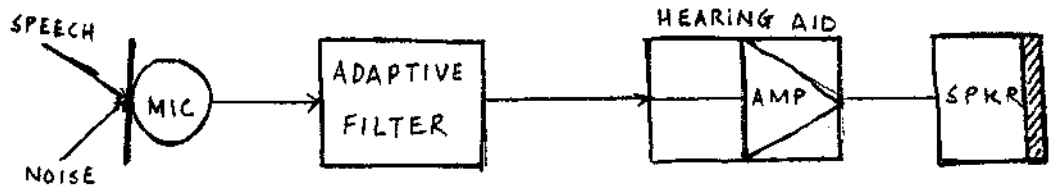

FIG - 2.



- Q. 9 a) Identify Fig-1 and Fig-2  
 b) How do the 2 differ in terms of their use.

FIG 1

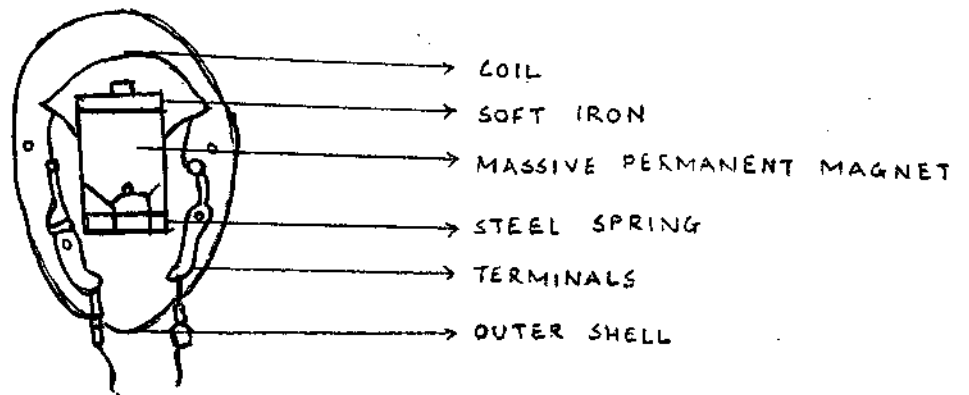
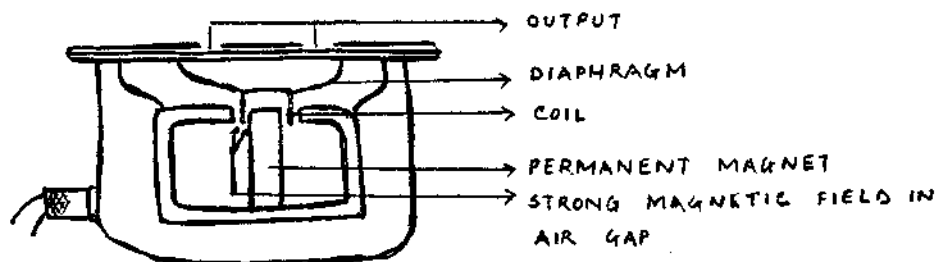
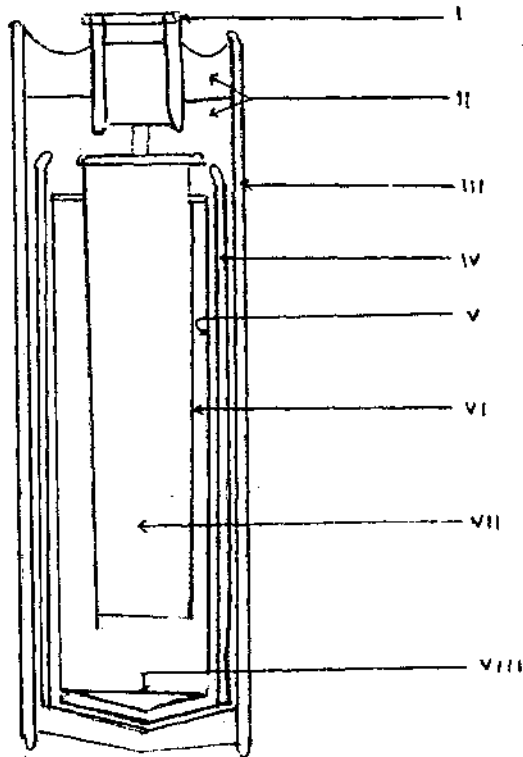

FIG 2.



Q.10 Match I-VIII of the diagram illustrating construction of a carbon-zinc type 'A' battery to its different parts.



- I Zinc can
- II Socket
- III Chemical mix
- IV
- V Paper bottom liner
- VI Carbon center electrode
- VII Paper outer shell
- VIII Paper liner

Q.11 a) This is an equipment required for measuring the \_\_\_\_\_ (LCOEETR OUSTAGIC FMNCPERORAE) of hearing aids.  
 b) Label A - I

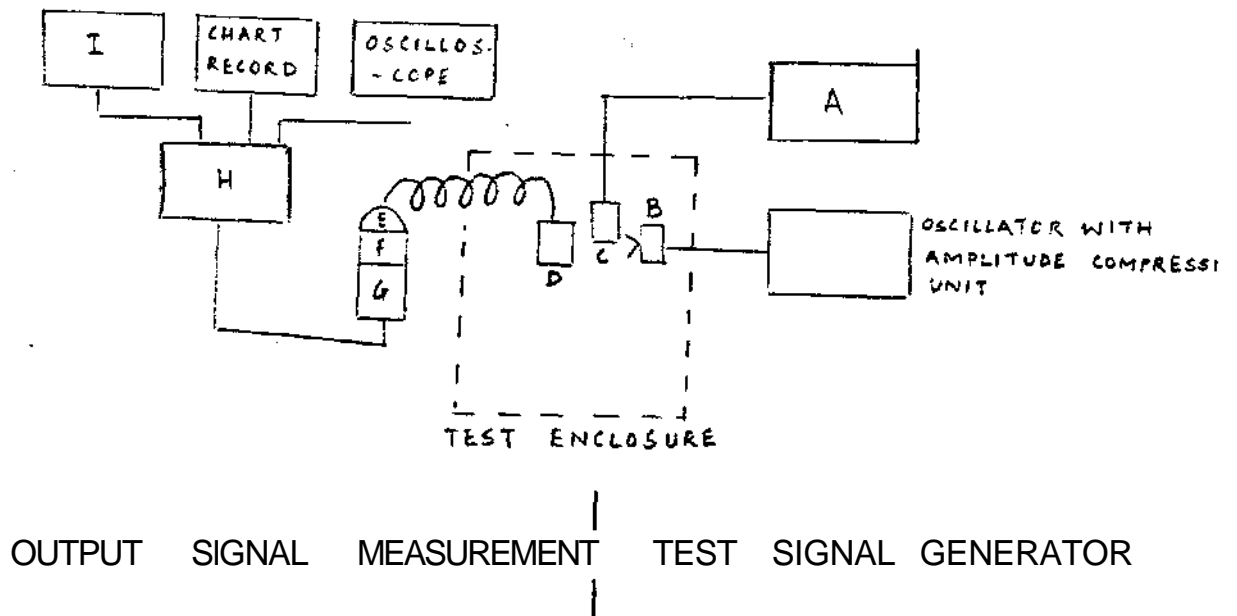

- Q.12 a) These are a set of circuits used for \_\_\_\_\_  
 b) Fill in the blanks A, B & G and explain each circuit.  
 c) Match circuits (i) (ii) & (iii) with their graphs  
 a, b & c

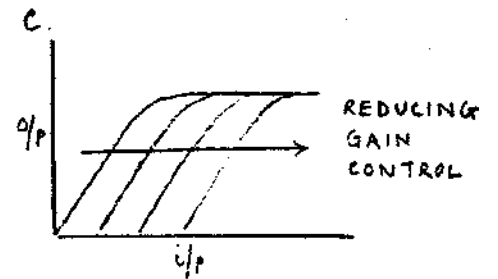
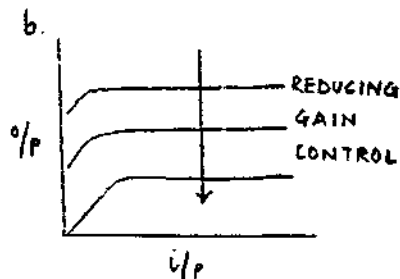
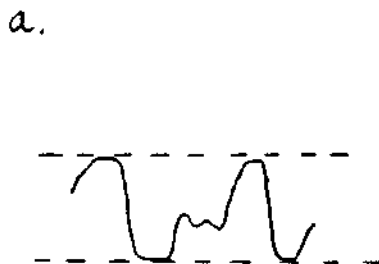
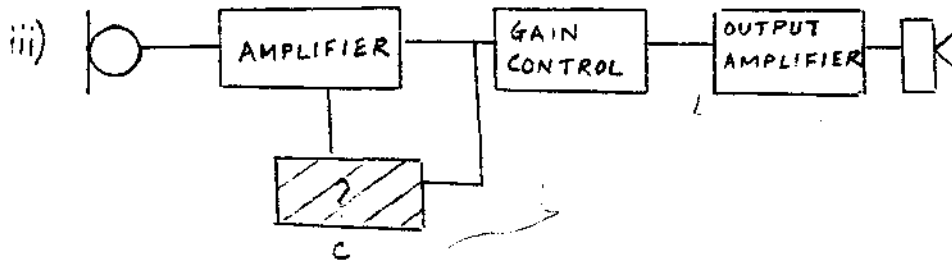
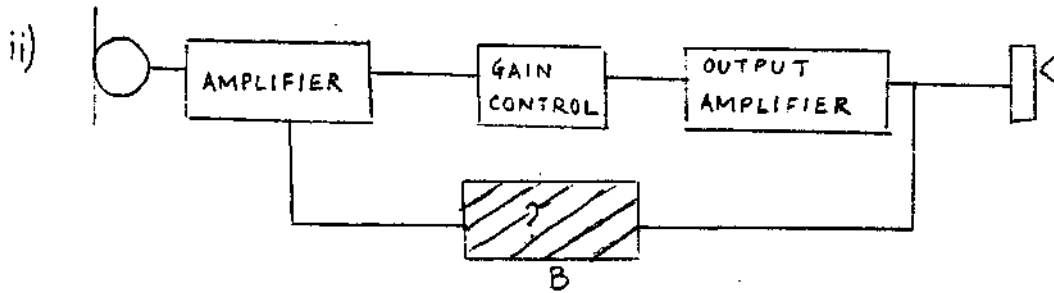
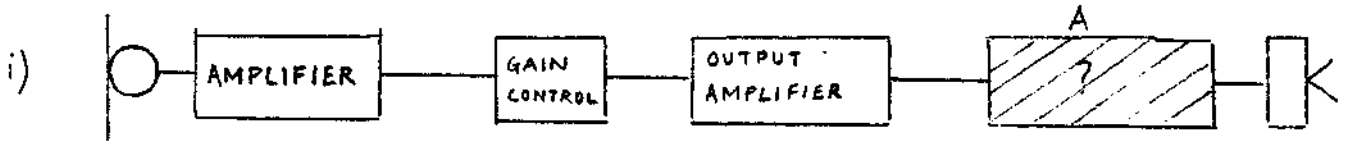

- Q.13 a) Which system does this schematic diagram represent,  
 b) Label the following after re-arranging the anagrams  
 1) IRPOMNCOHE    2) ETSRTNITAMR F.M    3) NNAATNE  
 4) M ECIREVRE.F    5) EDHNPPOAE.

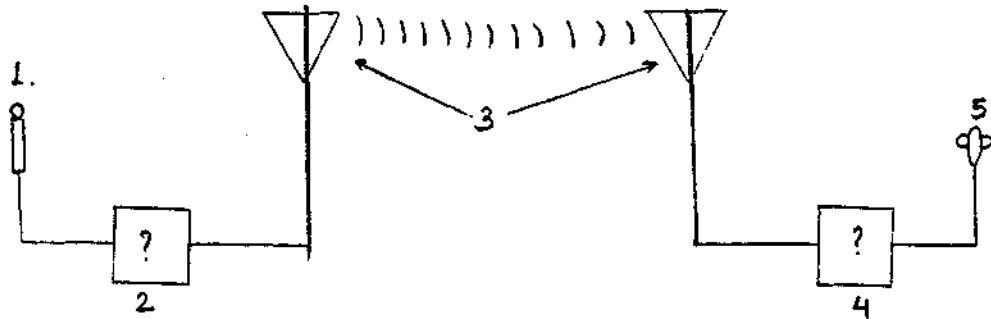

- Q.14 Arrange these parts to complete the block diagram of the SLM.

- > Hold circuit
- > Filter
- > RMS detector
- > Overload detector
- > Amplifier
- > Pre-amplifier
- > Display

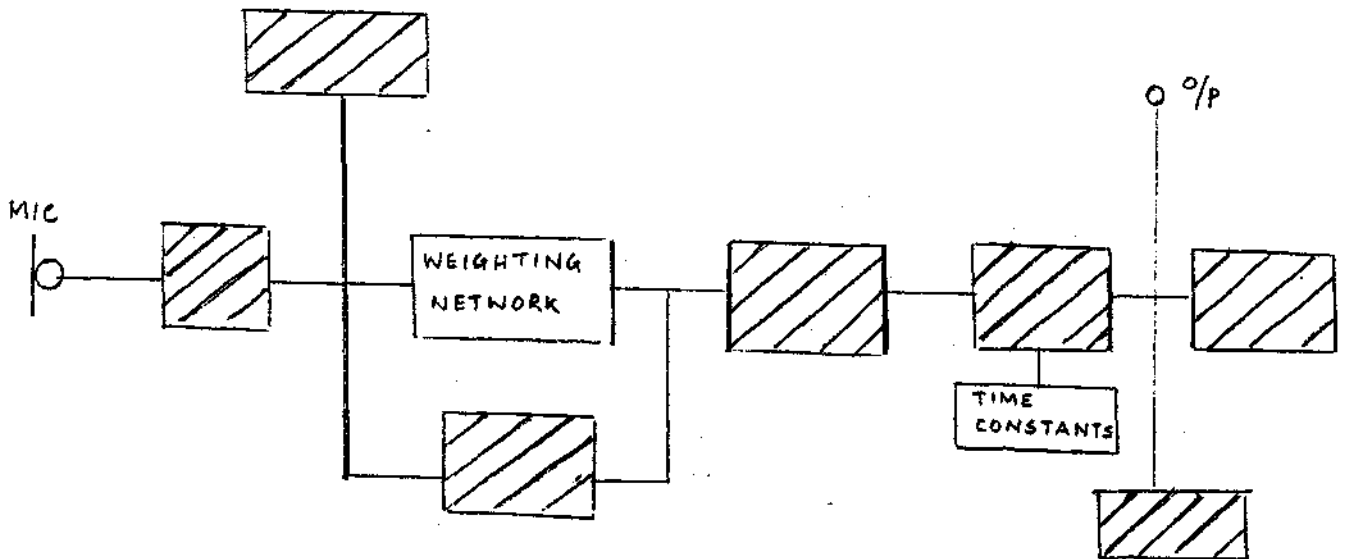

Q.15 This is a schematic diagram of calibrating \_\_\_\_\_  
 a) Sound Level Meter  
 b) Impedance meter  
 c) Audiometers

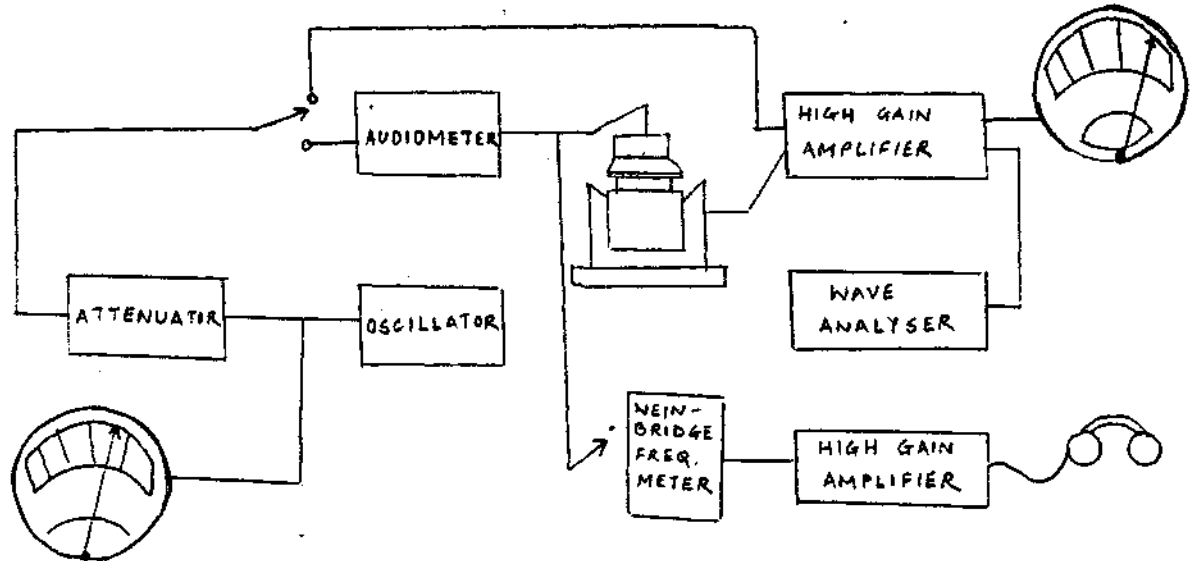

Q.16 a) Choose the correct answer -  
 This is a schema of-->  
 i) Johanson type transposer  
 ii) slowplay  
 iii) None of the above

b) Fill in the missing blocks

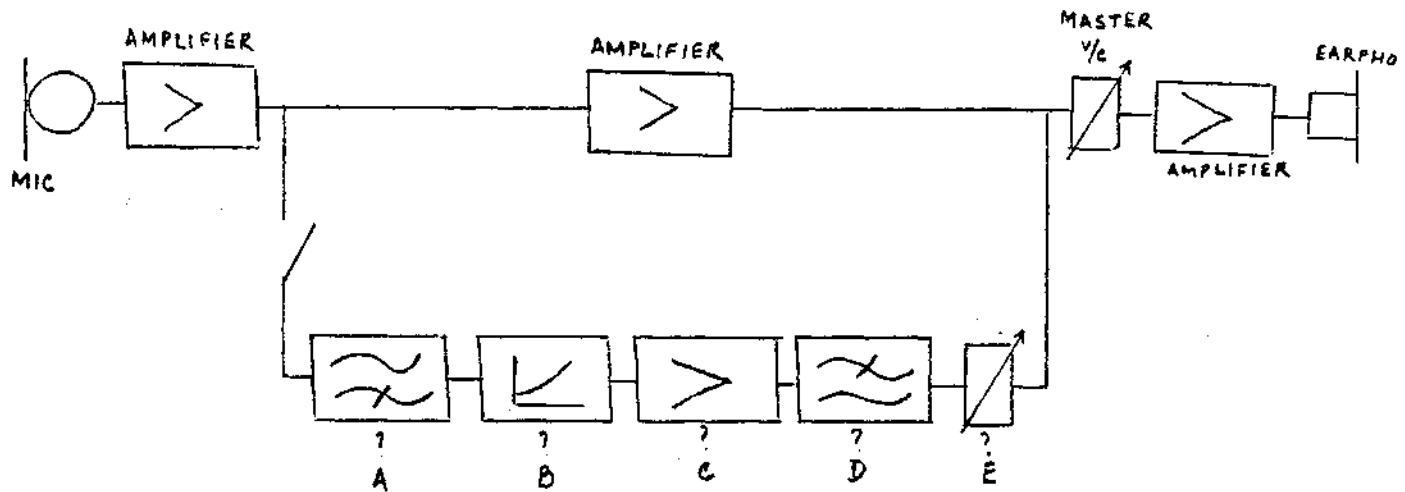

- Q.17 a) These are schematic arrangements for calibration of \_\_\_\_\_ and \_\_\_\_\_ -  
 b) Link the boxes in the correct order to get the right arrangement for calibration.

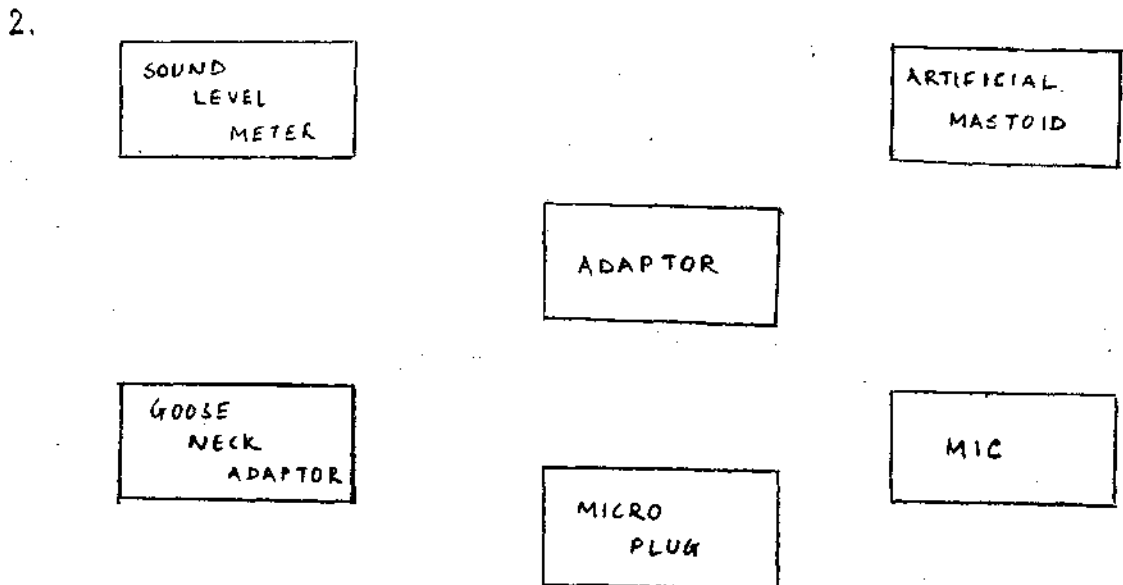
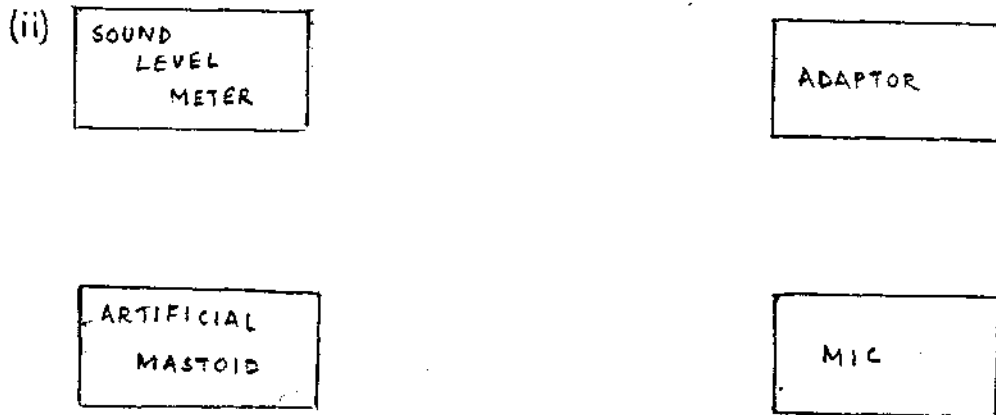
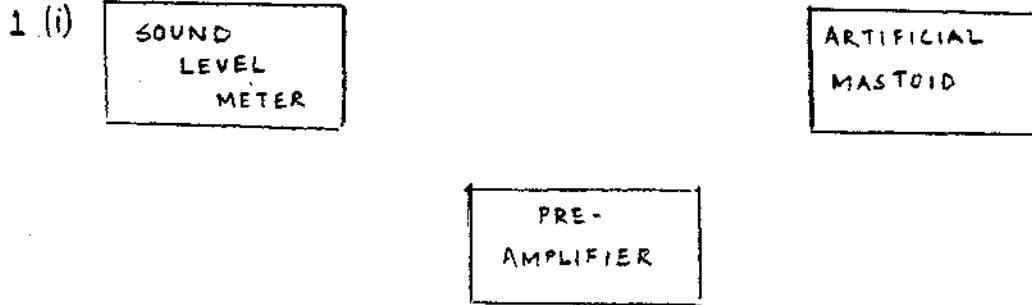



Q.18 a) This is an arrangement for the calibration of \_\_\_\_\_

b) Label the part marked (?)

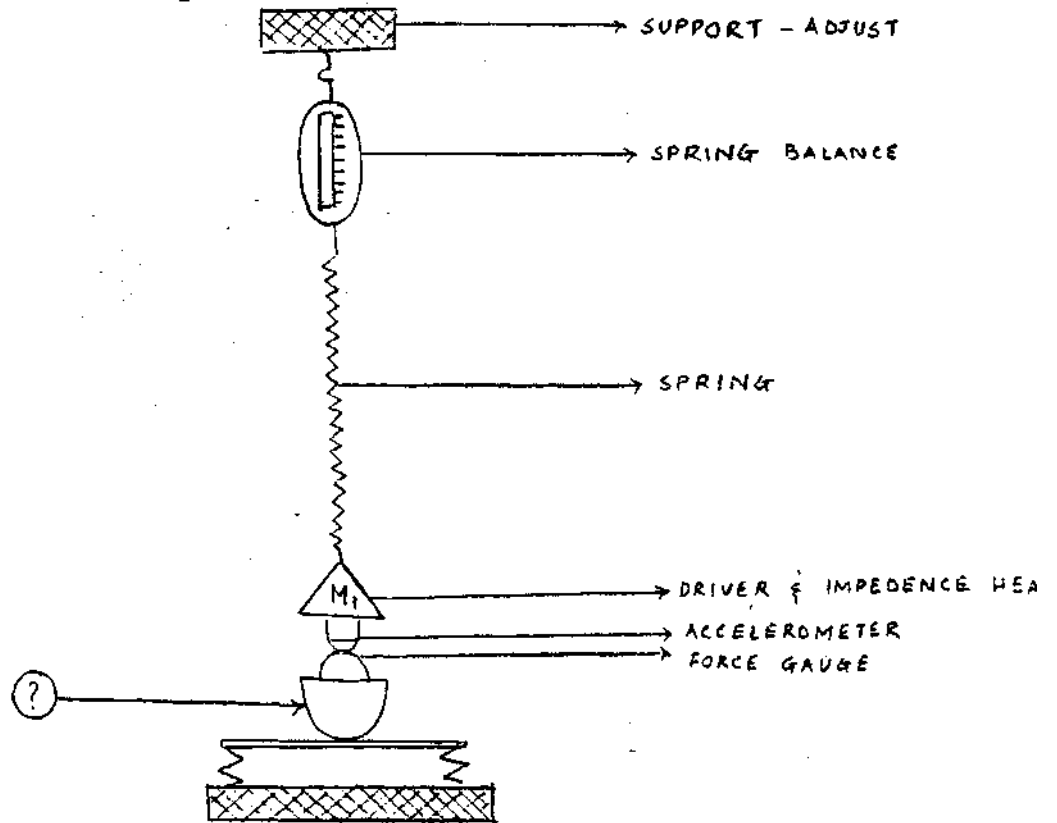

Q.19 Arrange these blocks in the right order so that they help in the calibration of the SLM.

ADAPTOR

PISTON  
PHONE

MIC

SOUND  
LEVEL  
METER

HEARING AIDS AND ASSISTIVE LISTENING DEVICES

Q.1 The all in one hearing aid.

a) Name the important parts and label them on the given diagram.

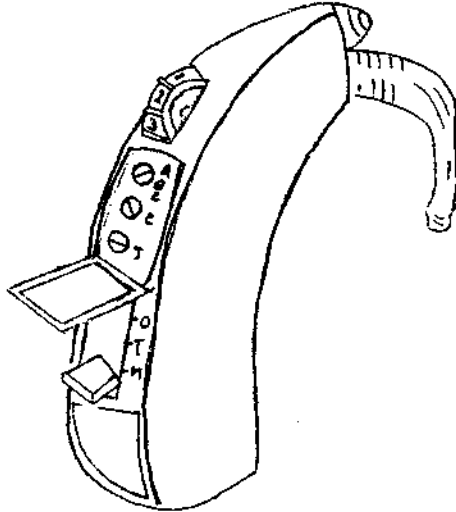

Q.2 a) Which system does this represent?

b) Fill in the boxes to show the transmission of sounds through this typical system.

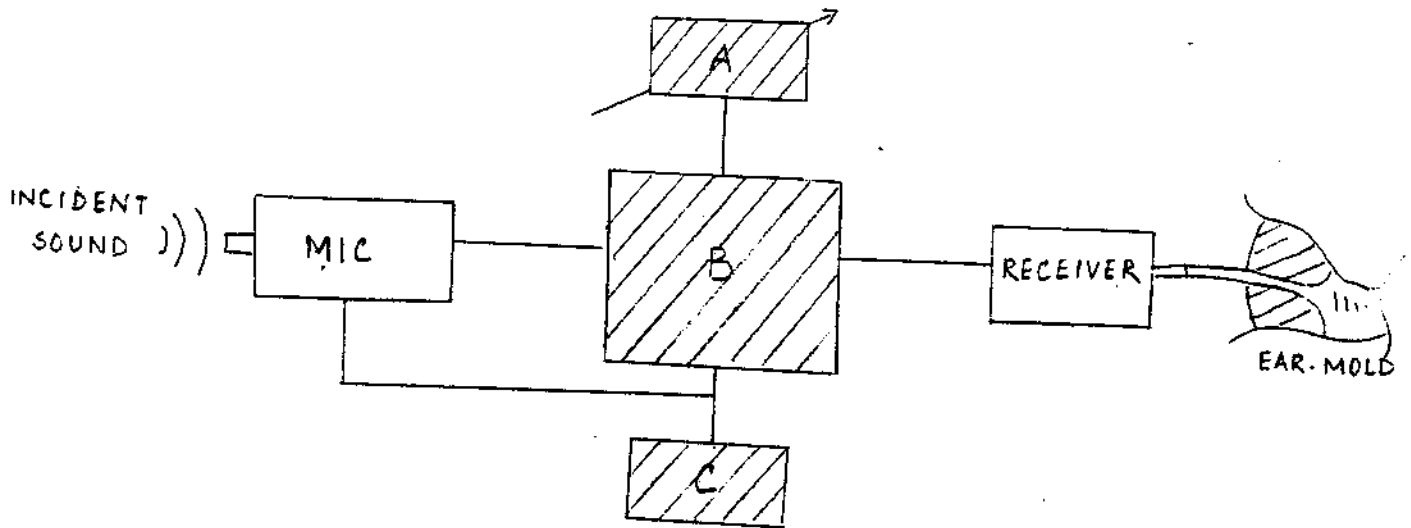

Q.3 a) These are commercially available different types of

b) Name them

c) State for what degree of loss each one can be prescribed.

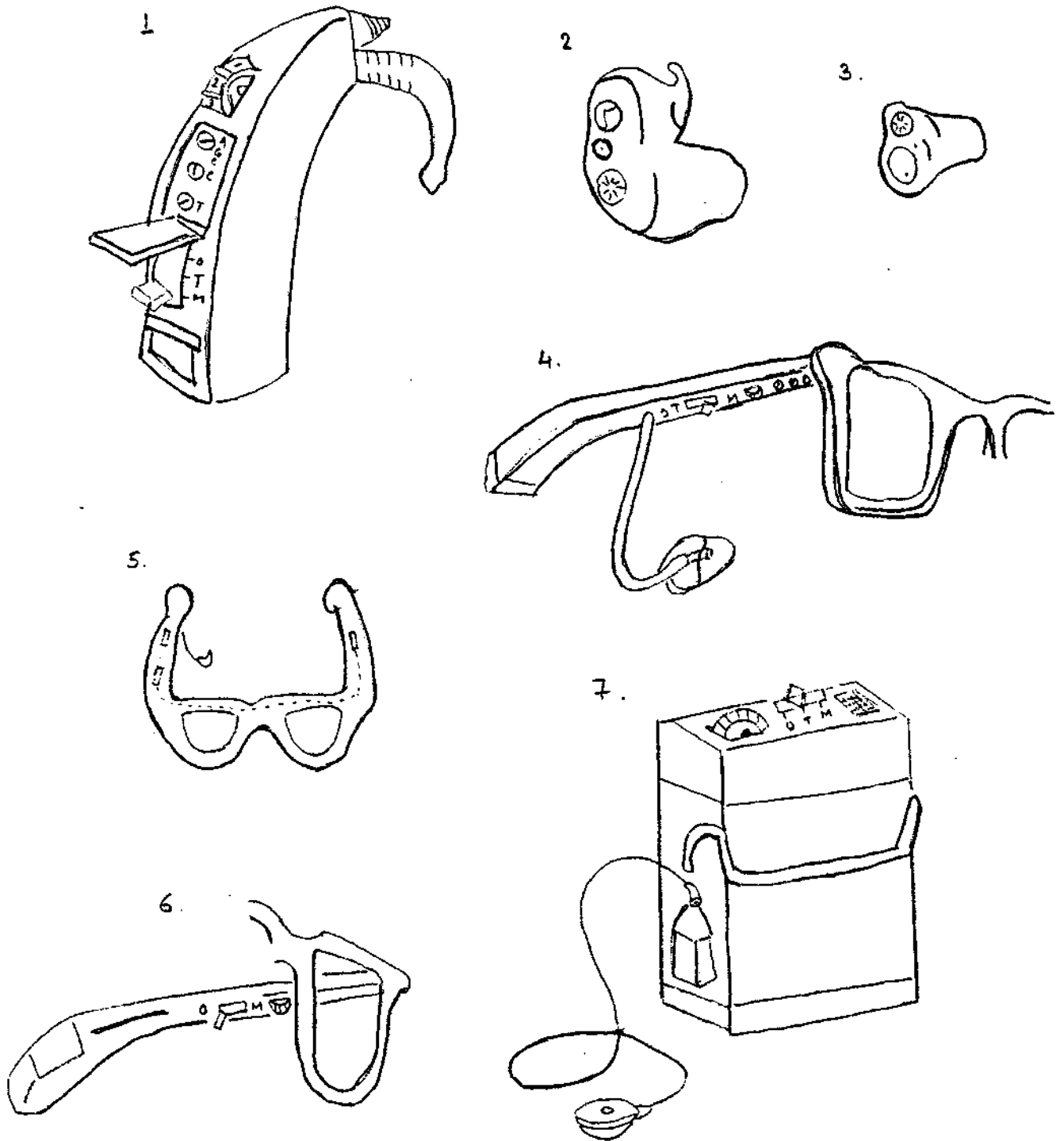

Q.4 The modifications in a hearing aid give its users maximum benefit.

- a) Now can you say what this graph signifies?
- b) Label A and B.

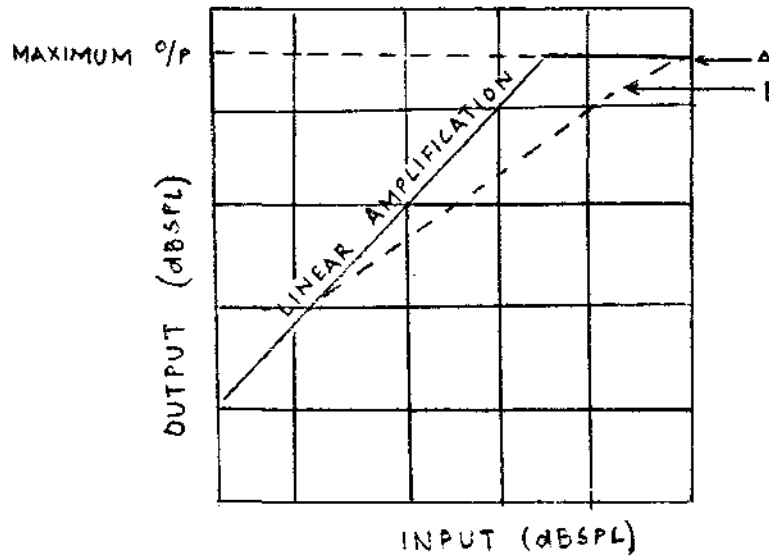

Q.5 This graph depicts the \_\_\_\_\_ of a typical in-the ear hearing aid.

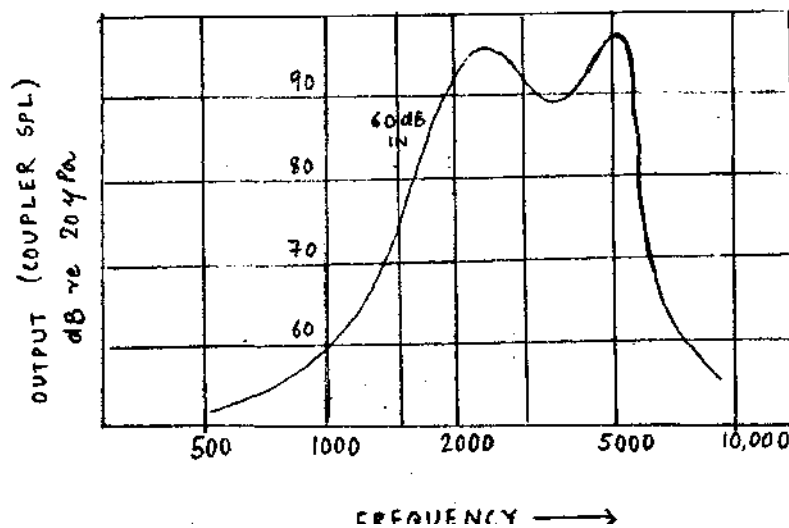

Q.6 After audiometry an audiologist gets these scores.

What kind of hearing aid would be most suitable for these patients?

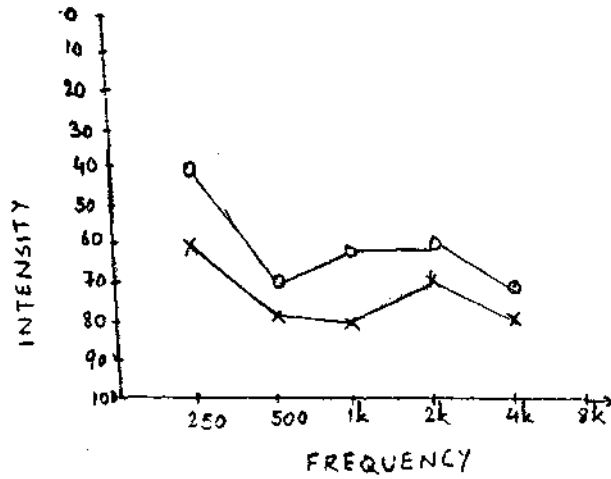

A

	Rt	Lt
PTA	68dB	78dB
SAT	58dB	72dB
<b>Aided</b>		
SAT	28dB	38dB
Discrimination	14/15	6/15

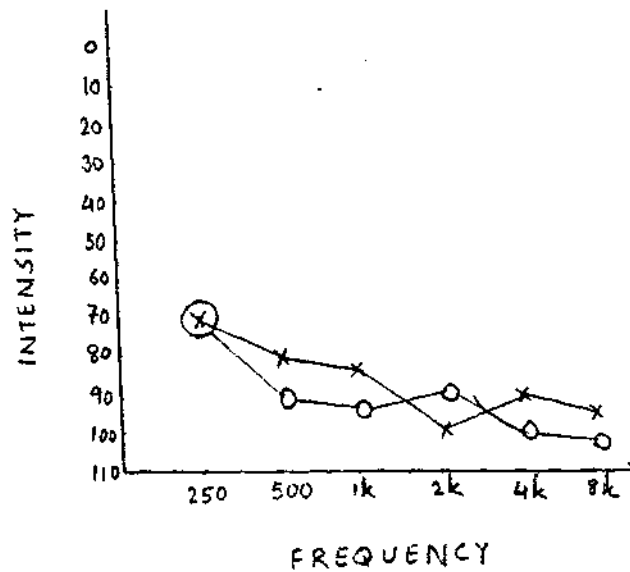

B

	Rt	Lt
PTA	90dB	83dB
SRT	78dB	72dB

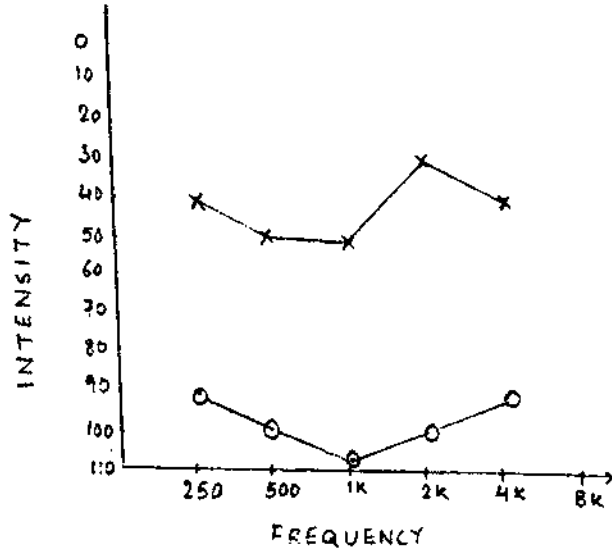

C

	Rt	Lt
PTA	105dB	45dB
SRT	25dB	85dB

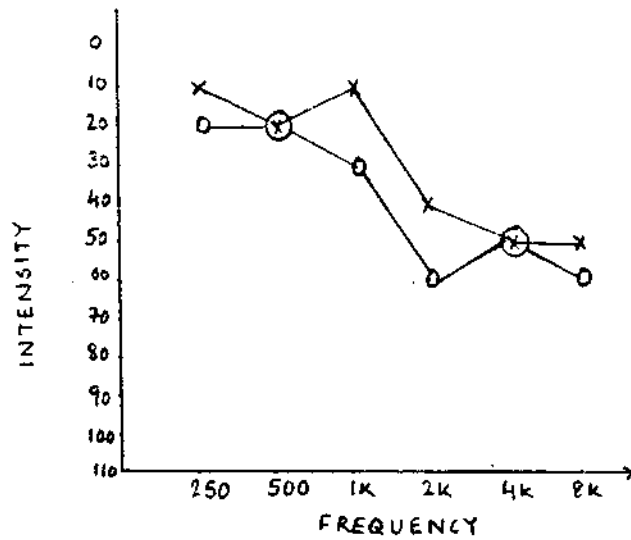

D

	Rt	Lt
PTA	20dB	13dB
SRT	26dB	16dB
Aided	SDS	70%
	Noise	60%

- Q.7 This is an important accessory of the hearing aid.
- Can you say what it is?
  - Name the parts.

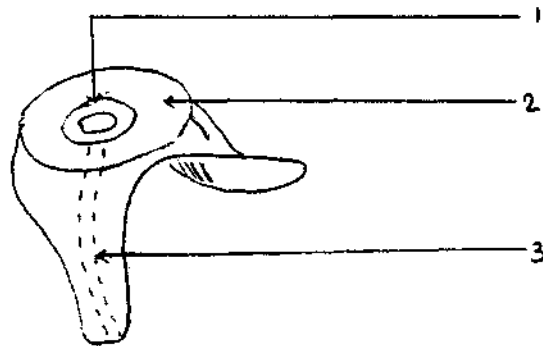

- Q.8 These are special modifications in the mold to provide maximum benefit to the user.
- Can you say what each one is called.
  - How is each one useful.

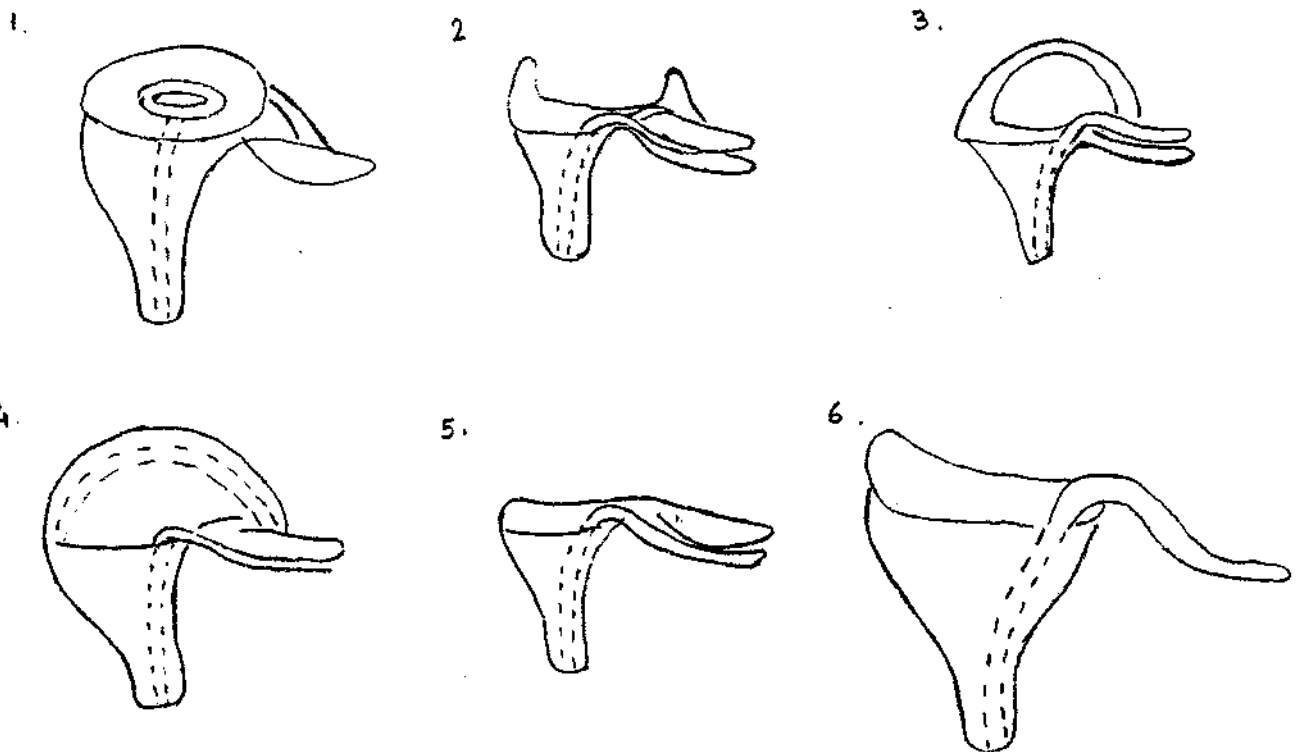

- Q.9 a) The ear mold not just forms a connection between the ear and the hearing aid, it also acts as an \_\_\_\_\_  
 b) What does this graph signify?

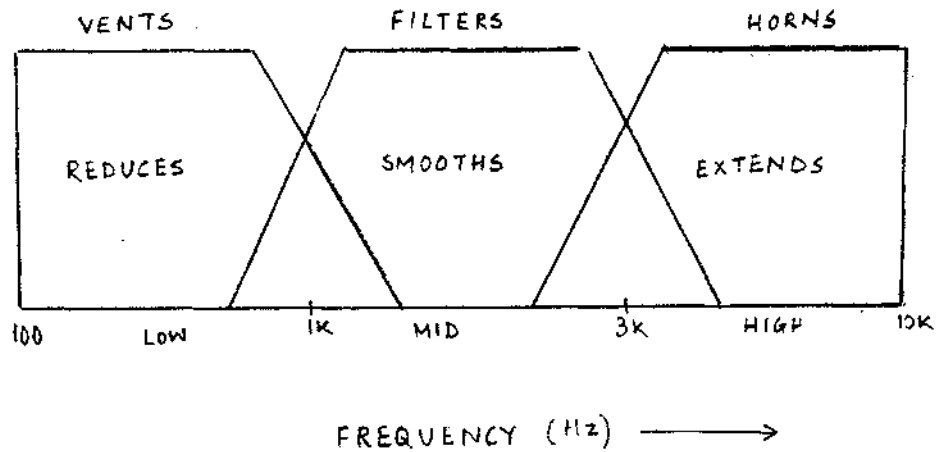

- Q.10 These are special modifications on the hearing aid.  
 a) What are these called?  
 b) Label the parts marked?

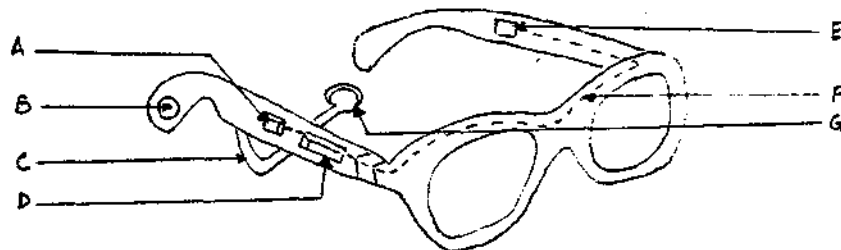



- Q.11 a) Expand on the acronym FROS.  
 b) Match the different types of FROS with their names.

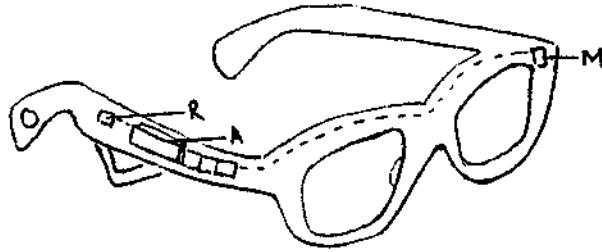

A) Bi FROS

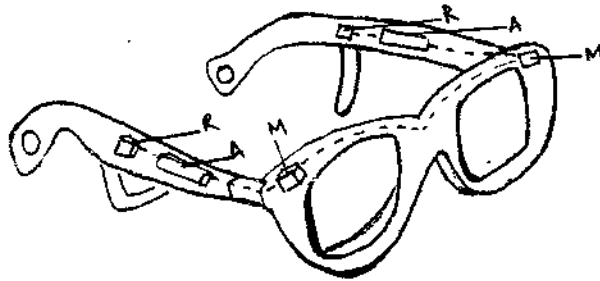

B) Double FROS

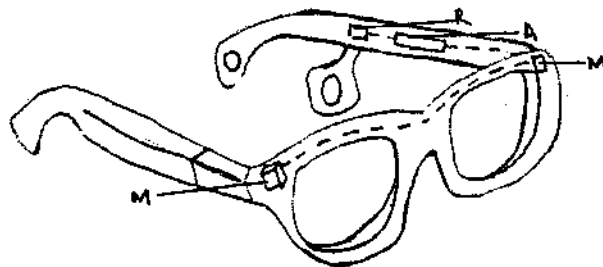

C) FROS

(R- RECEIVER , A- AMPLIFIER . M- MICROPHONE)

Q.12 This is an important component in hearing evaluation and hearing aid testing.

a) What is it ?

b) Mark the parts on the diagram.

--> PRESSURE EQUALIZATION CAPILLARY

--> 2CC CAVITY

--> AIRTIGHT SEAL

--> EARMOULD SUBSTITUTE / SEAL AROUND ITE AID

--> BUTTON EARPHONE / ACOUSTIC TUBE TO BTE -

--> CALIBRATED PRESSURE MICROPHONE

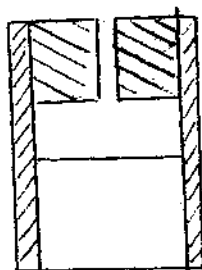

Q.13 Can you name these systems used in the measurement of hearing aid performance ?

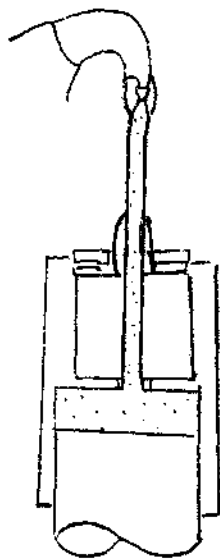

A

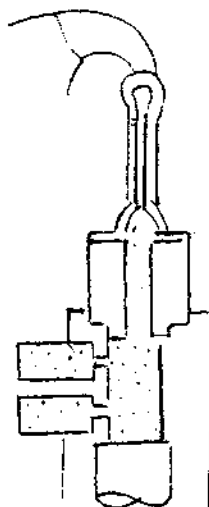

B.

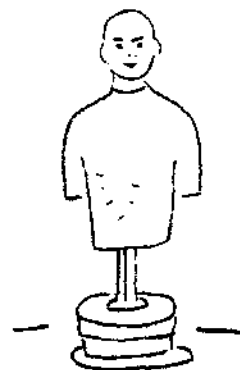

C.

- Q.14 a) These are a series of steps measuring \_\_\_\_\_  
 b) Arrange the different steps in the right order,  
 (i) 1,2,3 (ii) 3,1,2 (iii) 3,2,1  
 c) Describe the different steps.

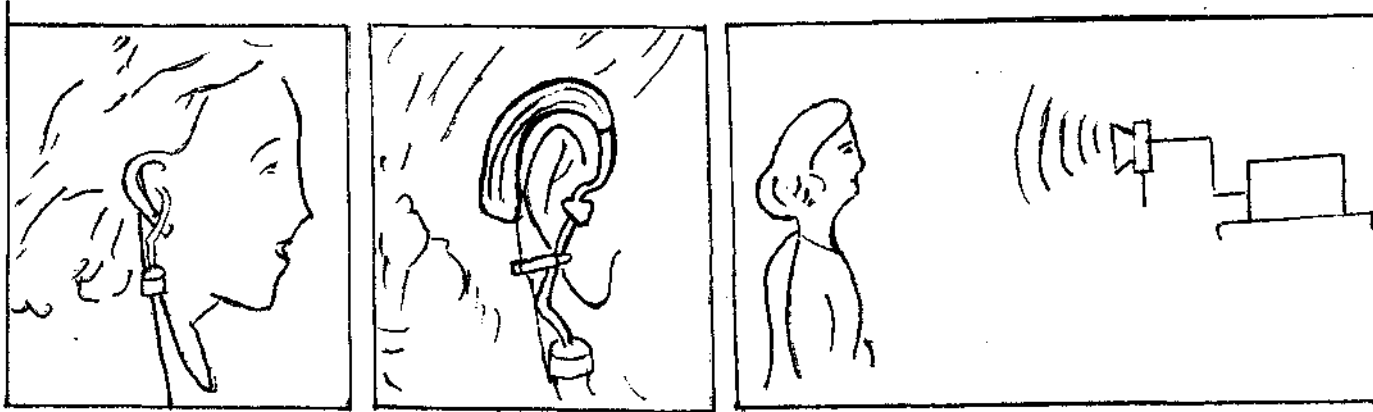

- Q.15 a) This is an arrangement for \_\_\_\_\_  
 b) Can you name the parts labelled ?

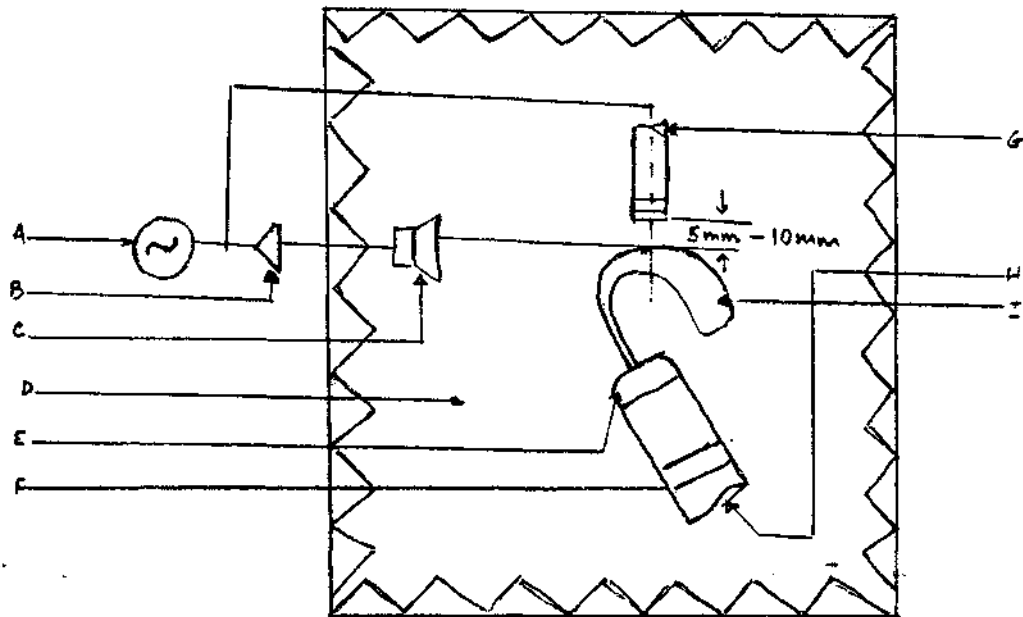

Q.16 a) What kind of testing is going on here ?  
b) What is its importance ?

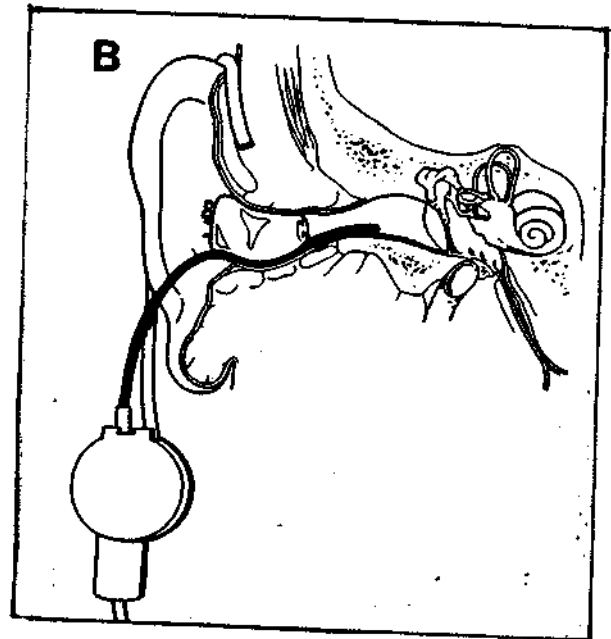
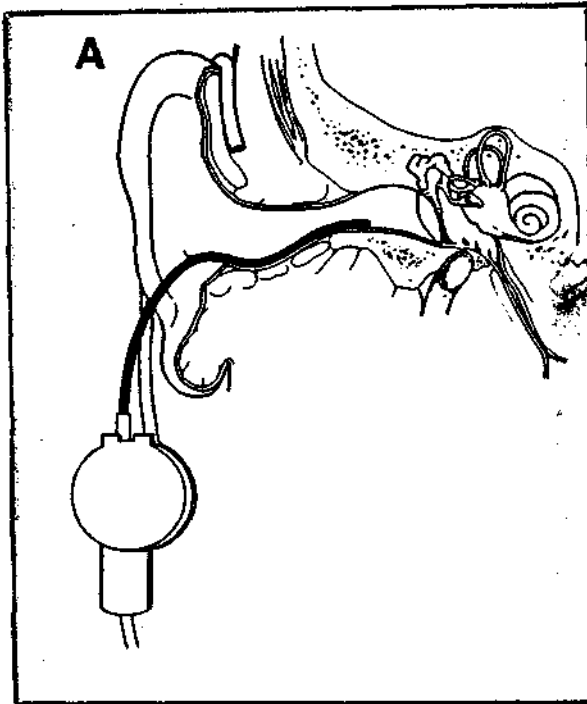

Q.17 Label A,B, & C on the graph.

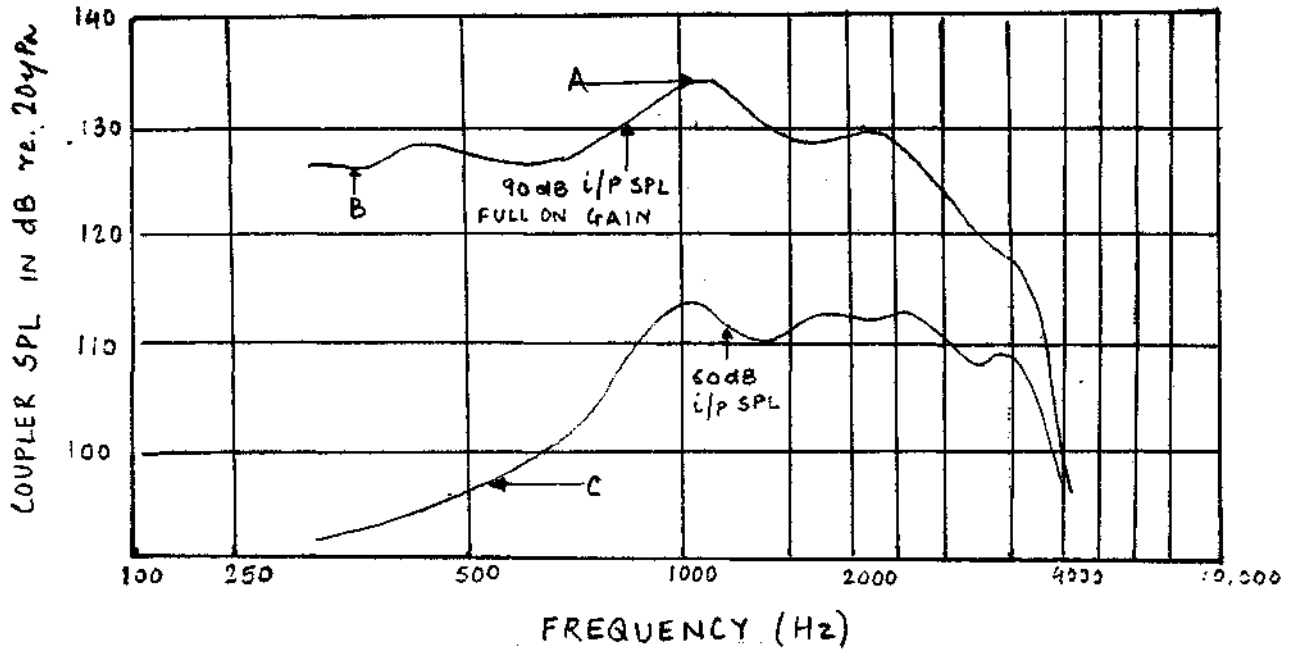

Q.18 This is a recent advancement in the field of hearing aids.

- Name and describe its functions.
- State its advantages.

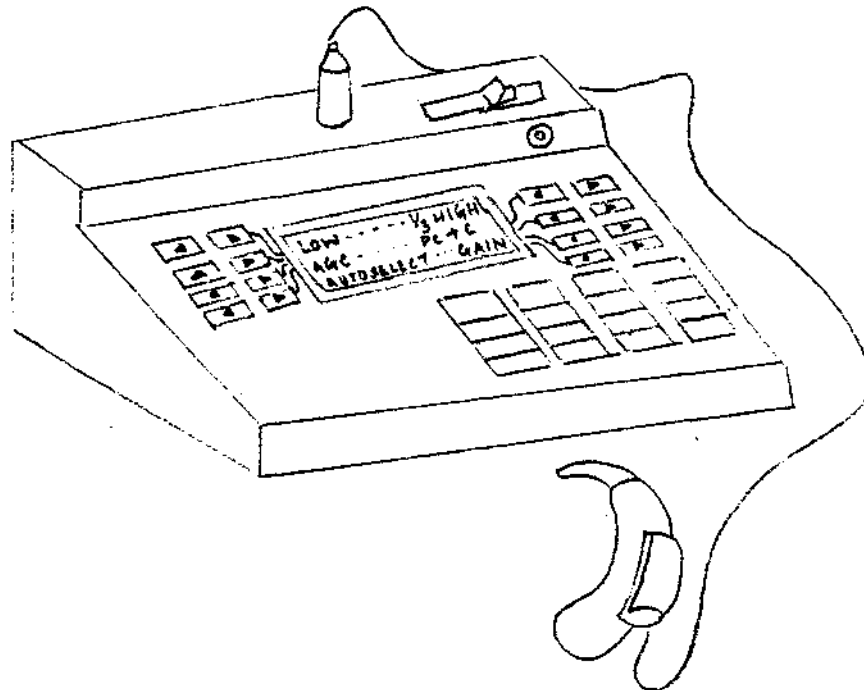

- Q.19 a) This is a recent boon to the hearing impaired individuals. Name it.  
b) Can you label the parts marked ?

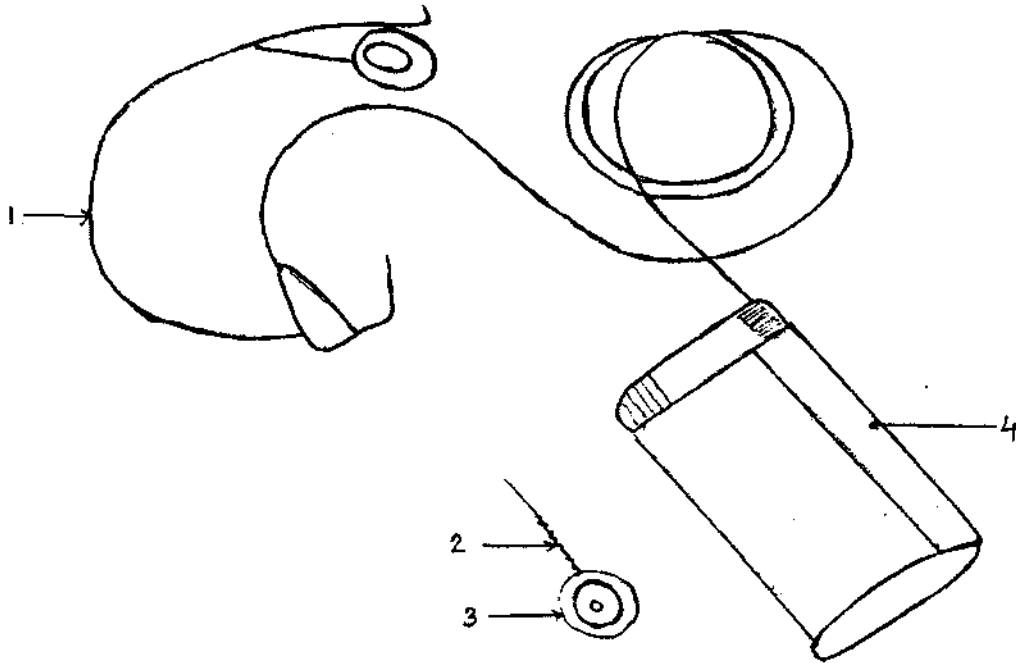

- Q.20 What is this and how is it helpful ?

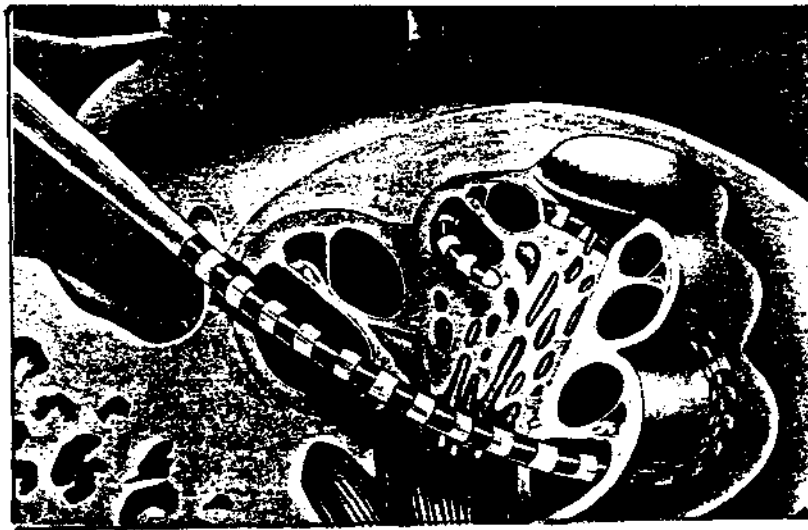

Q.21 These are devices which assist in listening.  
 a) They are called \_\_\_\_\_  
 b) Name them and label the parts.

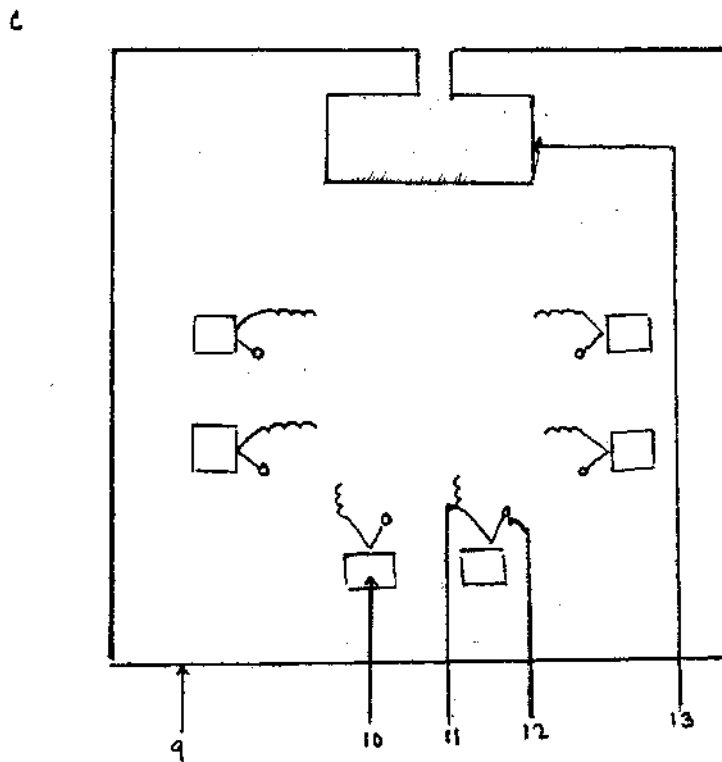
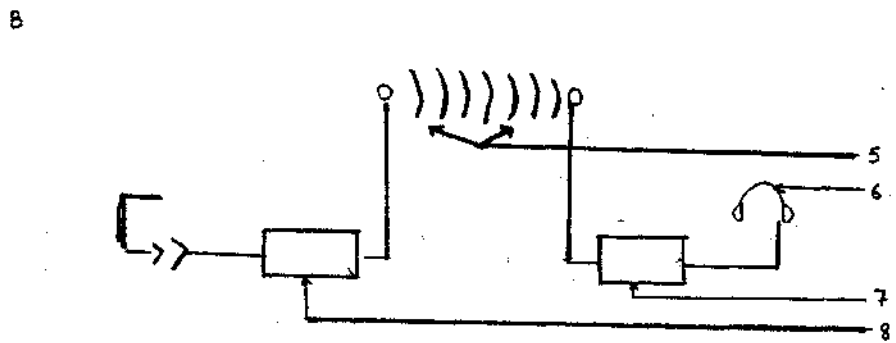
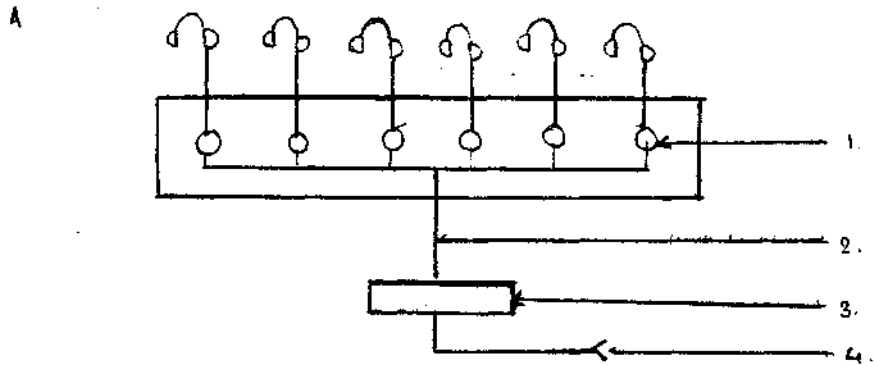

- Q.22 a) In addition to the auditory mode, most hearing impaired rely on \_\_\_\_\_ for communication.  
 b) This instrument has been devised to help these hearing impaired. Can you name it ?

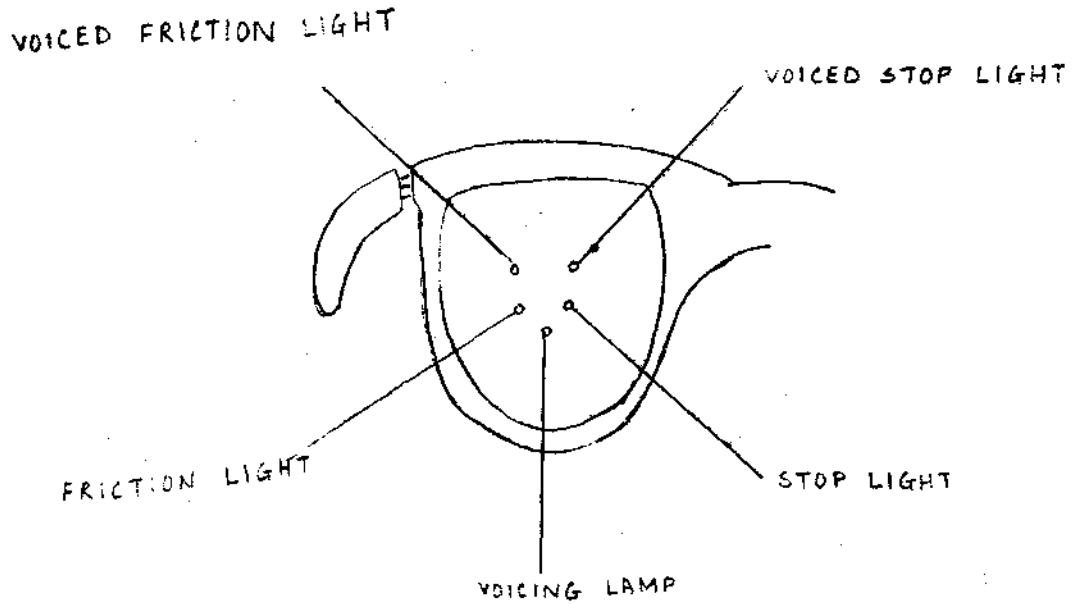

- Q.23 a) These are different modifications of which "group hearing - amplification system".?  
 b) Name them.

i)

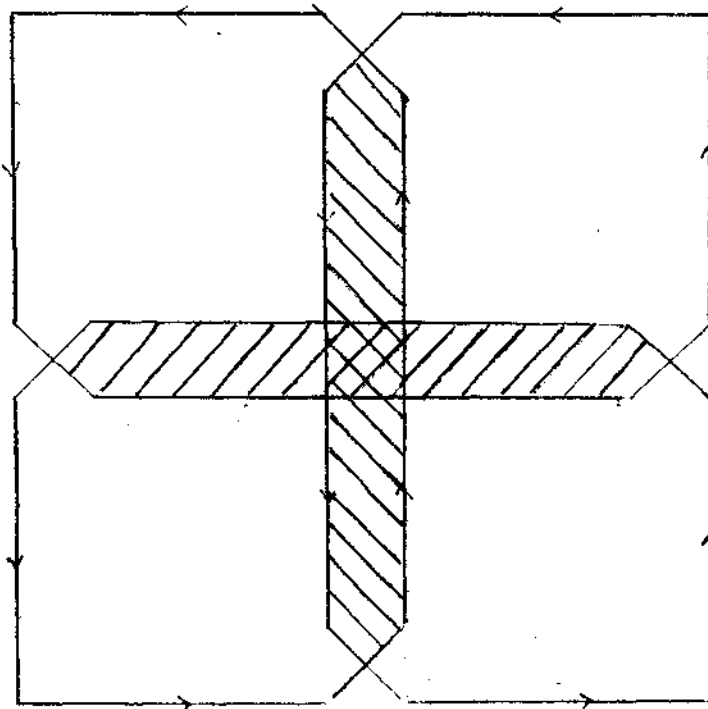

ii)

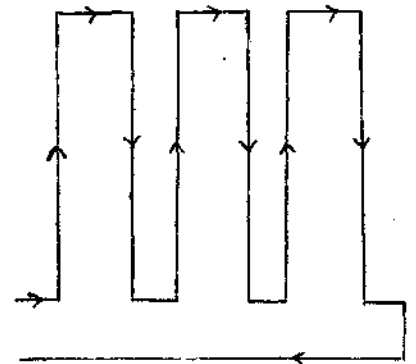



Q.24 These are certain recent modifications to help the hearing impaired. Name them.

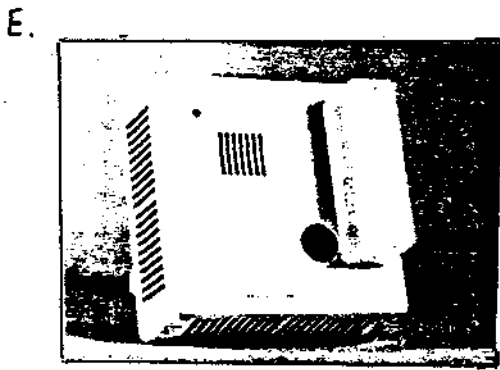
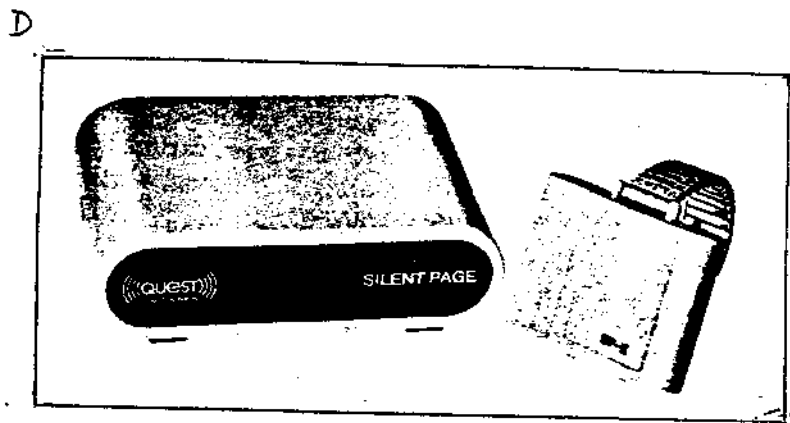
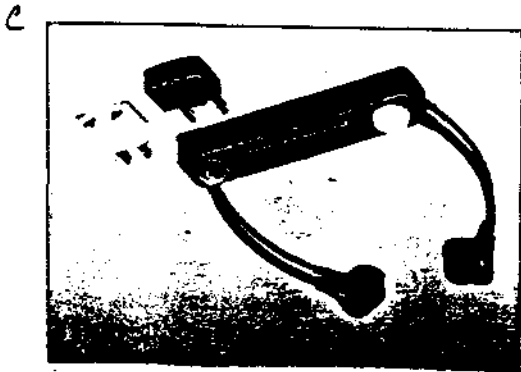
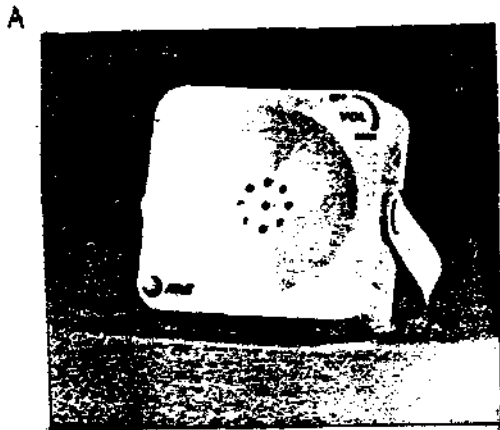

## NOISE

Q.1 What does this graph represent ?

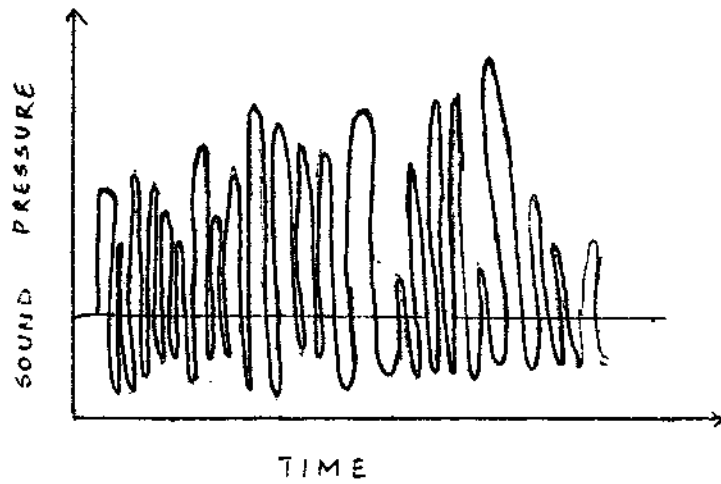

Q.2 a) What does this graph represent ?

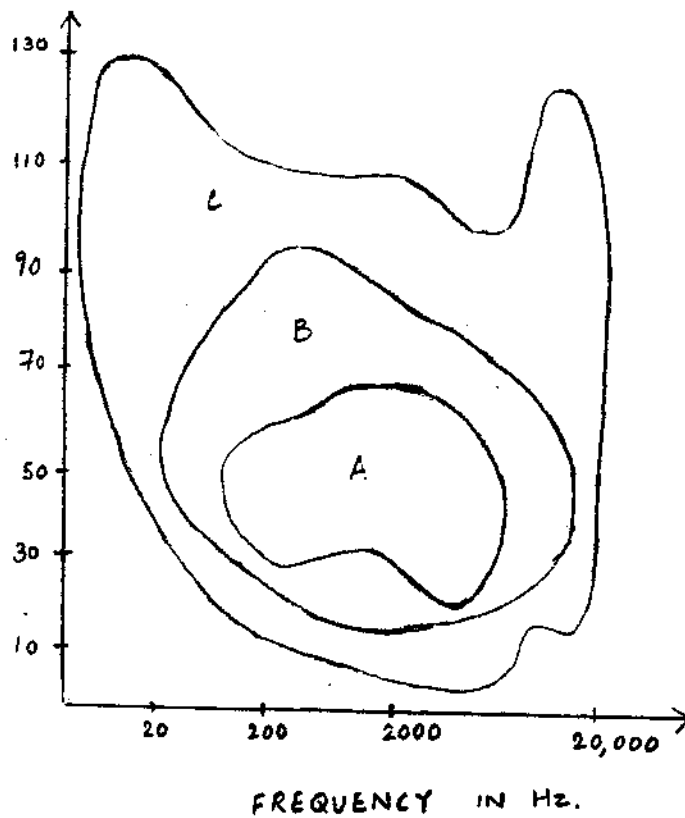

- Q.3 a) Name the different waveforms ?  
 b) Match them with their respective spectra.

**Waveforms**

**Spectra**

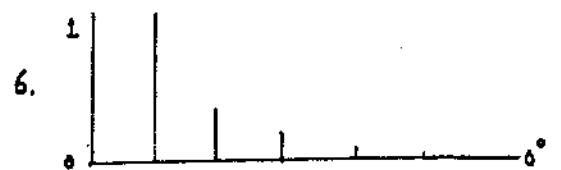
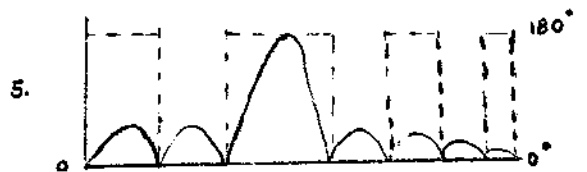
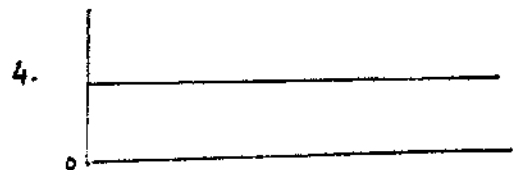
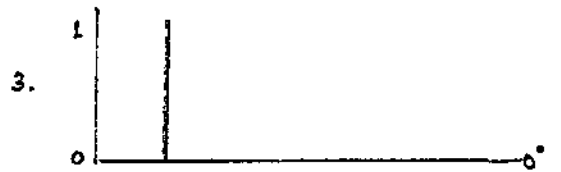
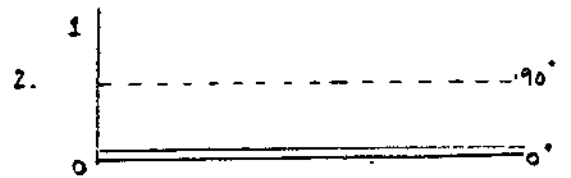
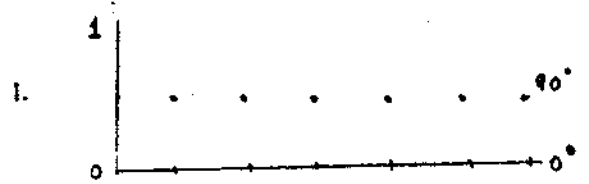
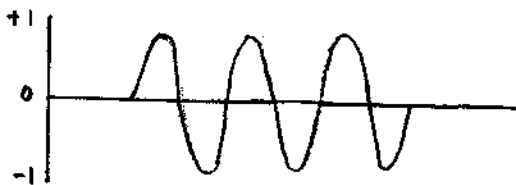
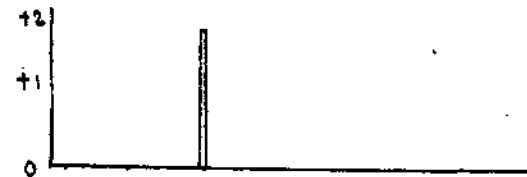
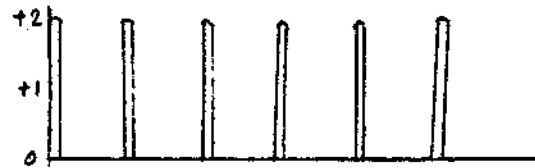
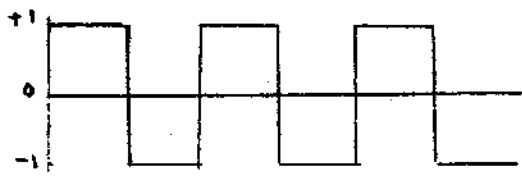
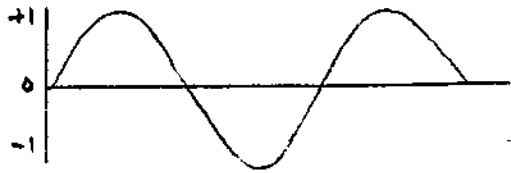

- Q.4 a) What does this graph depict ?  
 b) Label the X axis and Y axis, the dotted lines, the loudness levels.

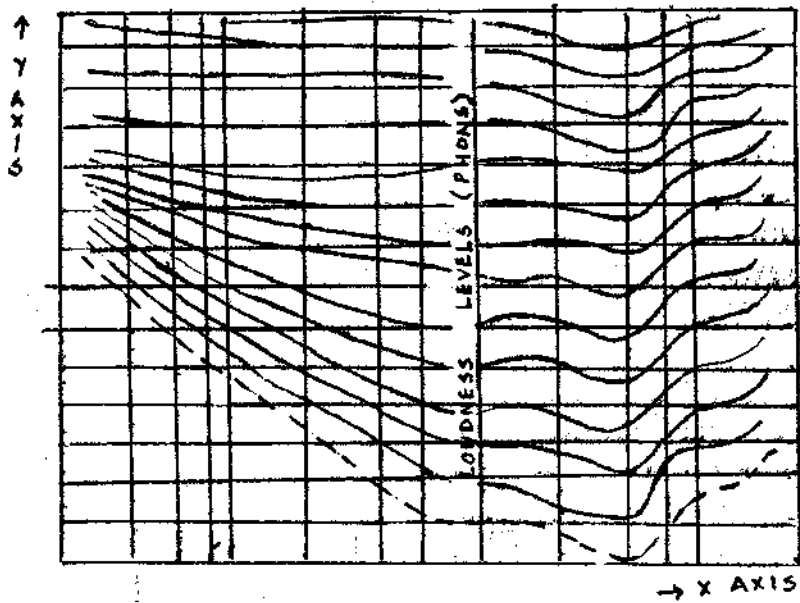

- Q.5 This is a schematic diagram of the 'noise' pathway - to the Inner ear.  
 Label the boxes.

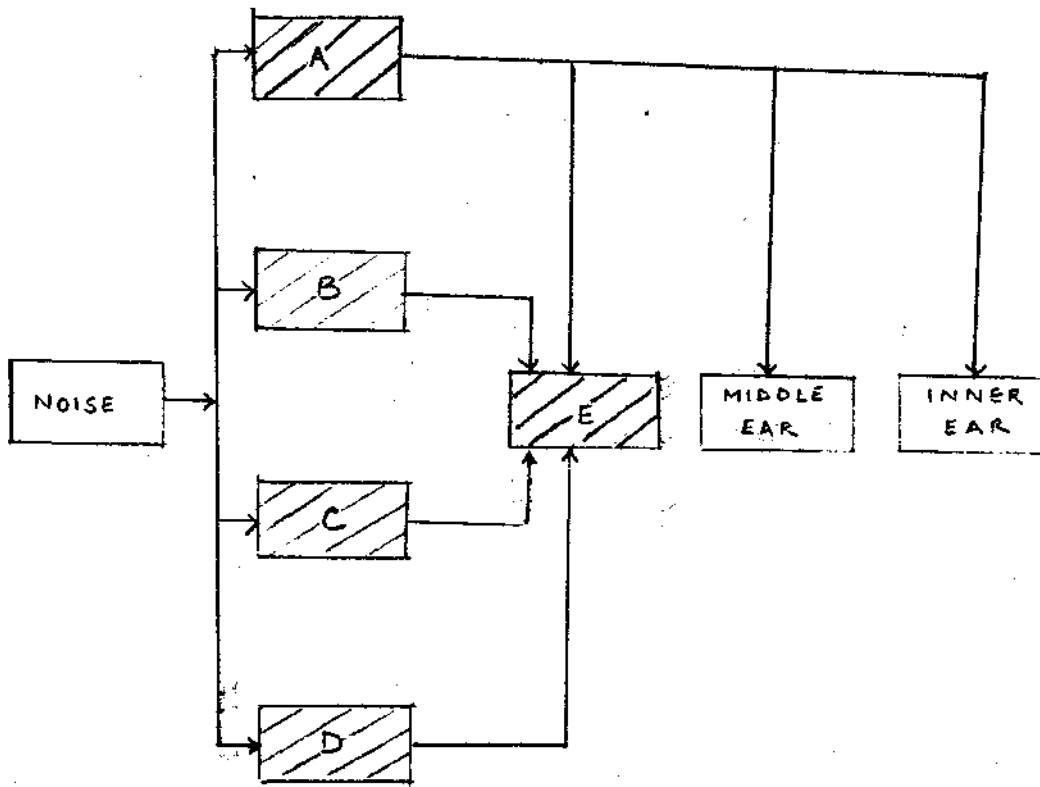

- Q.6 a) Which part of the ear is this ?  
b) What is wrong ?  
c) What caused it ?

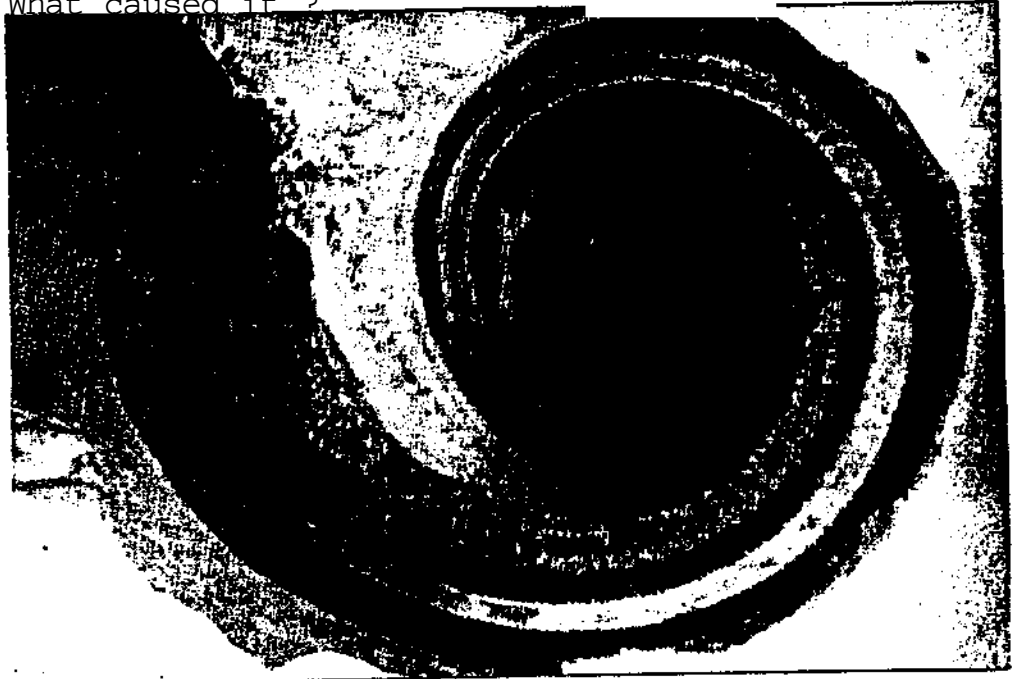

- Q.7 a) Move UP, DOWN, DIAGONALLY & BACK and find 12 inner ear structures which undergo changes on exposure to noise.  
b) Mark those parts on the diagram.

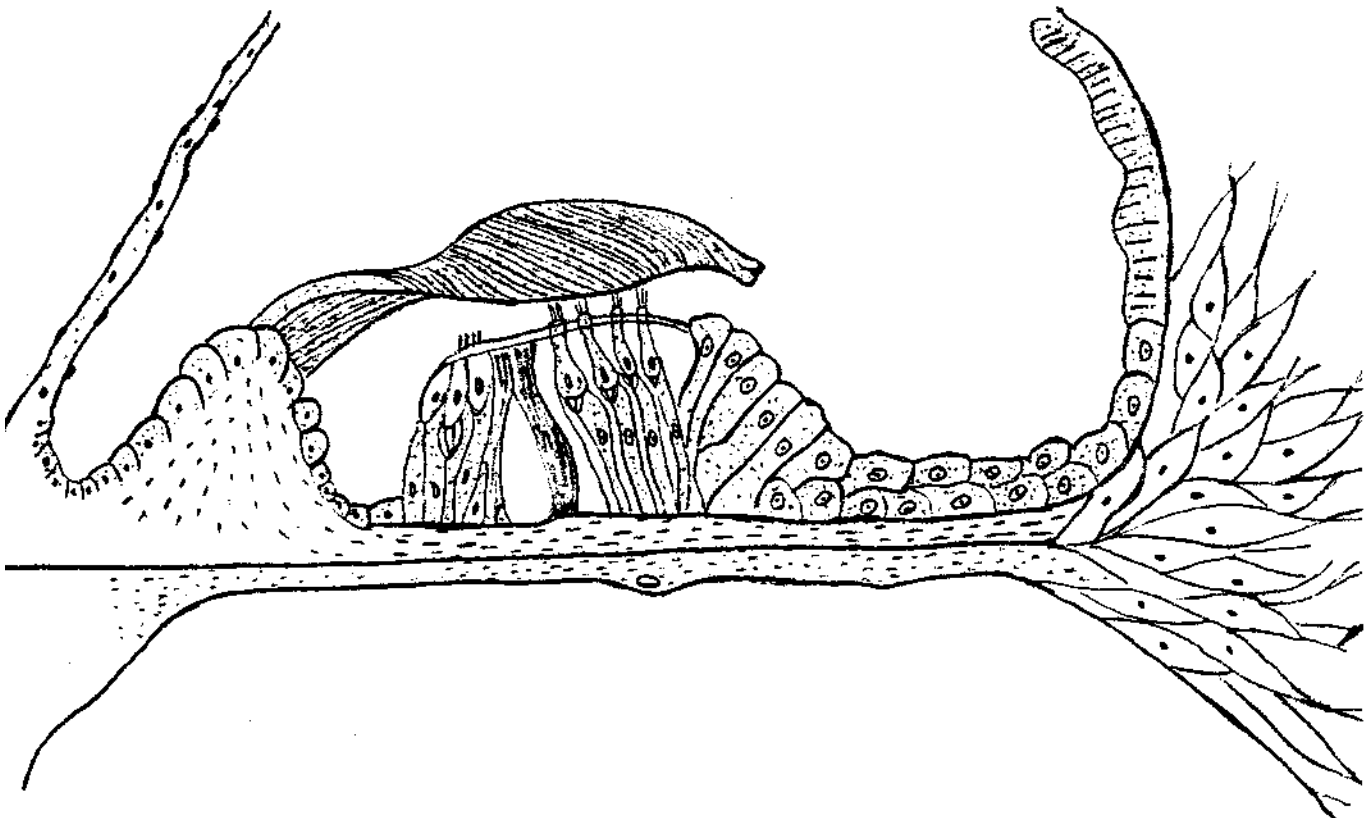

L L E C R I A H R E N N I D U E S I S S 0  
S A L L E C S R E T I E D S I S P T P R B  
I I S N G A A Y I H T R U T A L I Y I E A  
R R U A V A N I A N A B R P N L R N R C S  
A D M E Y A S M I N M 0 N R U E A P A R I  
L N A N N A N D I I C 0 Y E R C L A L S L  
U 0 N I S N U A L F C C A M A N L N L U A  
C H A N U M A L 0 M N E I A D E I I I I R  
S C S P I R A L U E S S E L A S M C G 0 H  
A 0 K 0 D R E N E G 0 C Y L G N B L A M E  
V T L 0 I N N A S M V L E V T E U A M N M  
A I A P N M Z U I M U U R I L H S M E H B  
I M S U N R E T I C U L E R L A M I N A R  
R E T C I L L C I T 0 P L A S. M N N T 0 A  
T P L W C I E I H L E D R I L I S A I A N  
S I L U S T N S A V A S A L L A N M I H E  
D E N D 0 P L A S M I C R E T I C U L U M  
H R E A E N A R B M E M S R E N S S I E R  
S E T I R D N E D N L L E C R A L L I P X  
S I E C N. E N I M 0 R P L A R I P S U D E  
U T S 0 E T A M L L E L R I A H R E T U 0

Q.8 This is a typical audiogram seen in cases with noise induced hearing loss.  
Choose the correct one.

A.

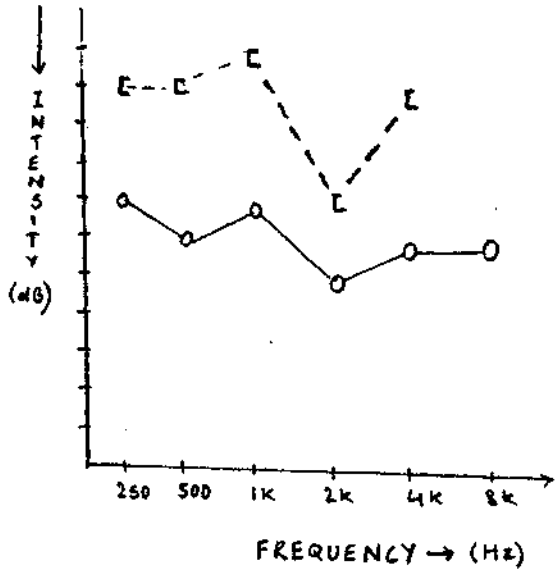

B.

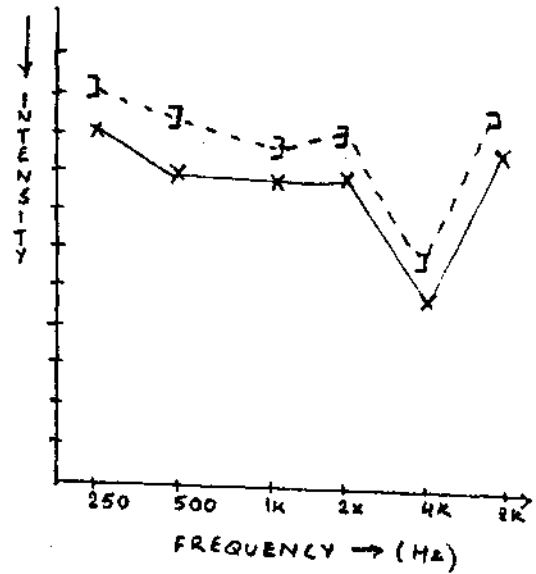

C.

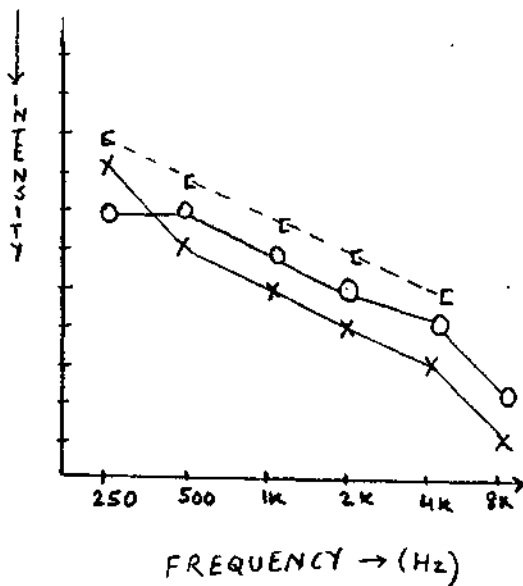

D.

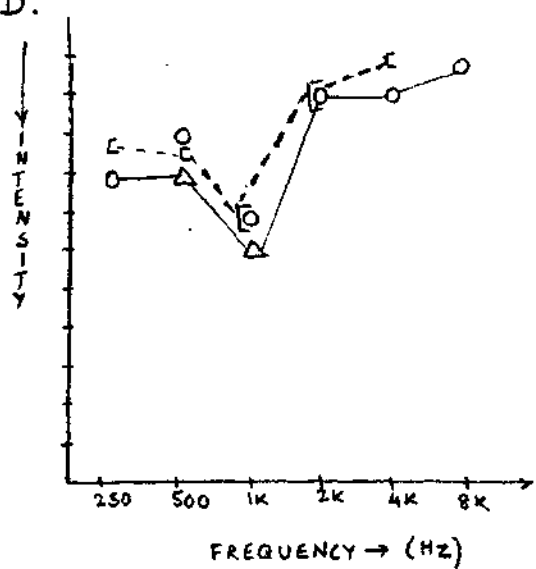

- Q.9 a) Name the instrument and say what it is used for.  
 b) Label the parts.

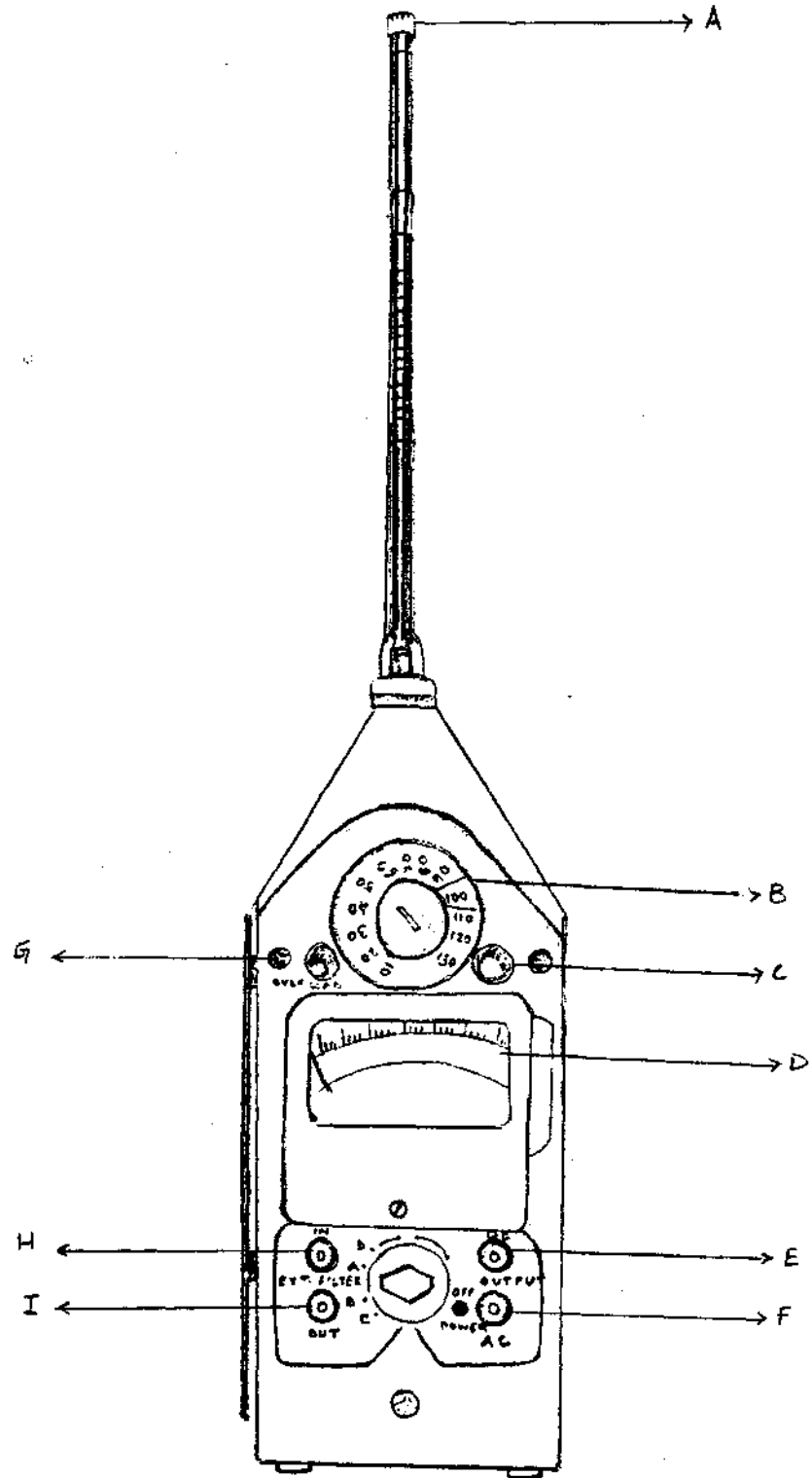



- Q.10 a) Name the instrument to which these accessories belong.  
b) Name the accessories stating their use.

1.

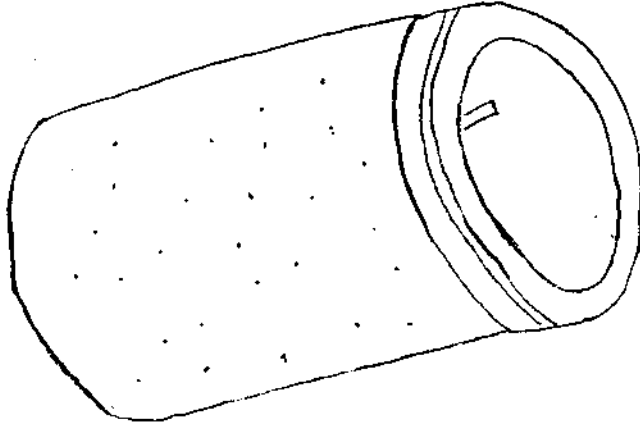

2.

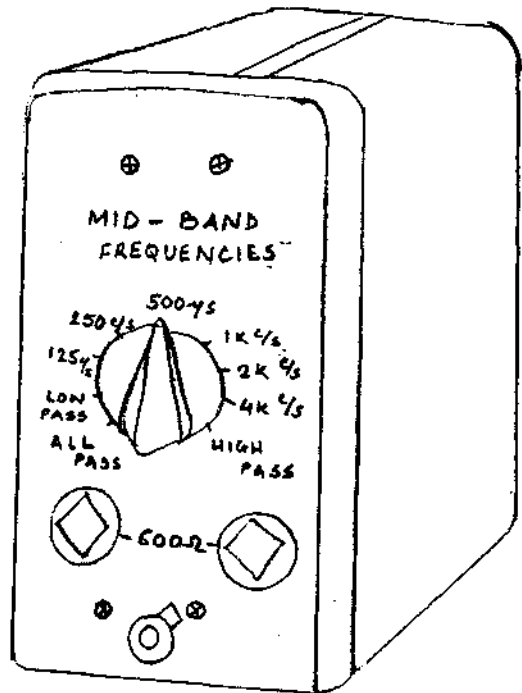

3.

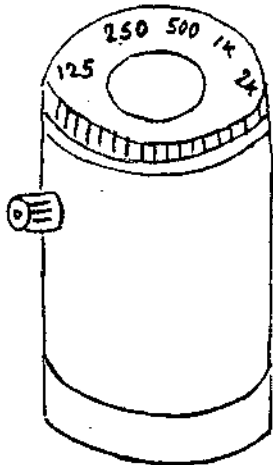

Q.11 What does this graph represent ?

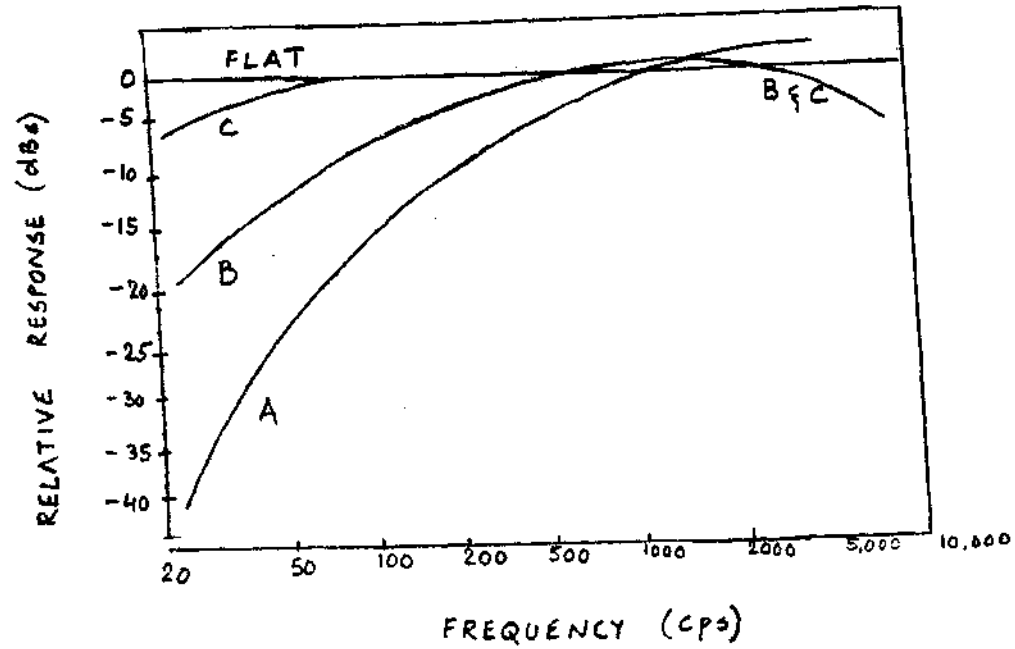

Q.12 a) What does this graph represent ?

b) Choose the correct one :-

This was given by --

- i) OSHA
- ii) AAOO
- iii) AMA
- iv) CHABA

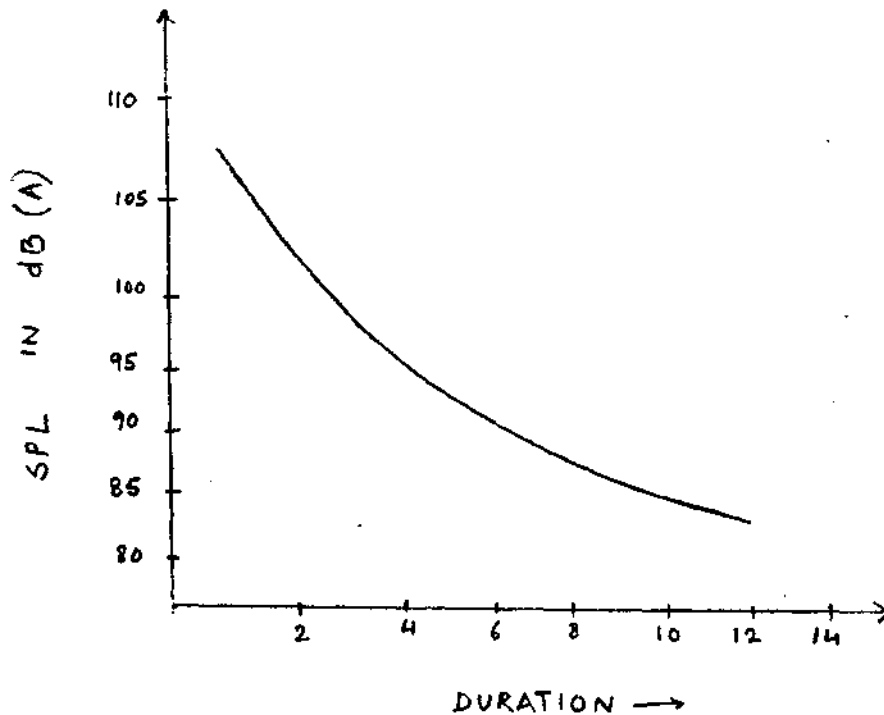

Q.13 a) The ear is protected from noise by the use of \_\_\_\_\_  
b) Name them.

1.

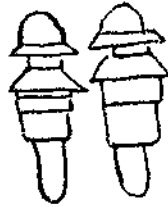

2.

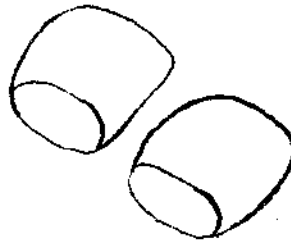

3.

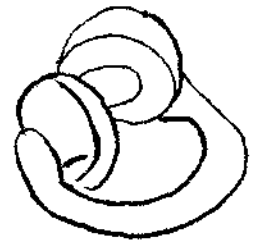

Q.14 a) This is a graph representing \_\_\_\_\_ of Ear protective devices.  
b) Label the 3 lines on the graph.

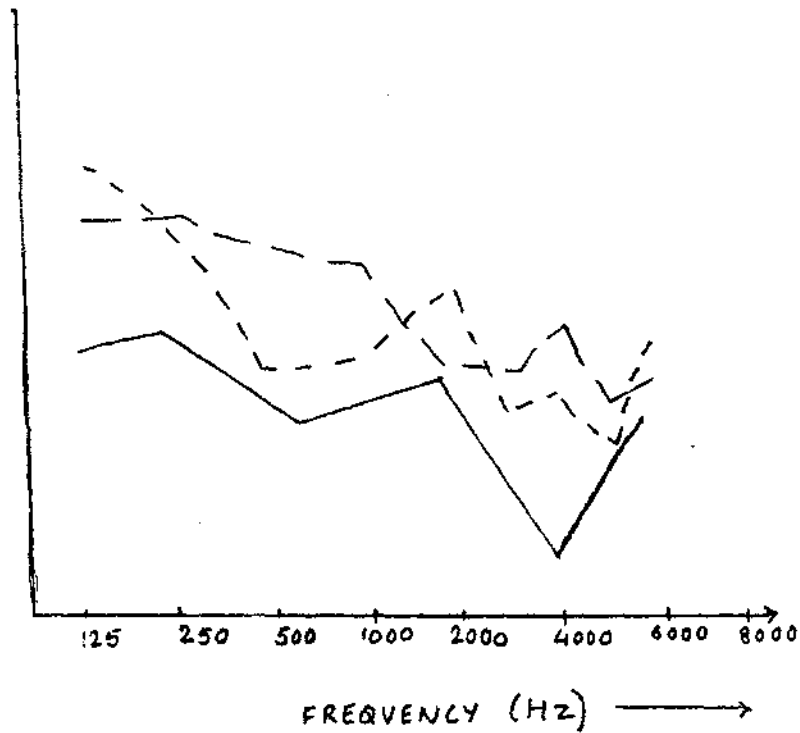

- Q.15 A) Which is this instrument ?  
Choose the correct one:
- a) Sound Level Meter
  - b) Octave filter set
  - c) Accelerometer
  - d) Noise dosi meter

B) How is it useful ?

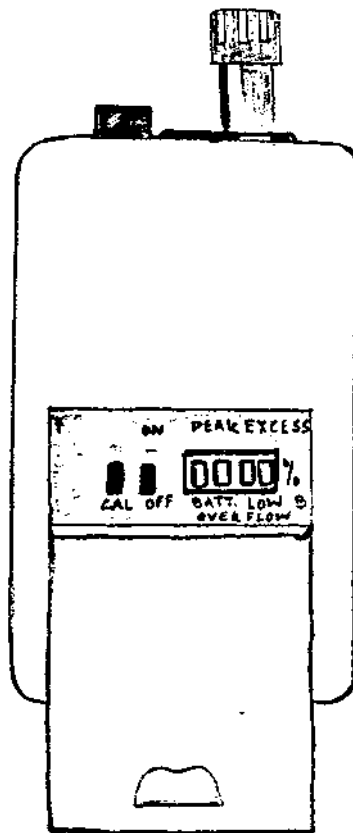

Q.16 a) These are different ways of attenuating \_\_\_\_\_ and \_\_\_\_\_ from a machine.

b) Arrange the pictures in proper order, to ensure the purpose, by following the right path.

A) 2, 4, 6, 3, 1 (B) 6, 5, 2, 1, 4, 3 (C) 3, 4, 5, 2, 1, 6

1

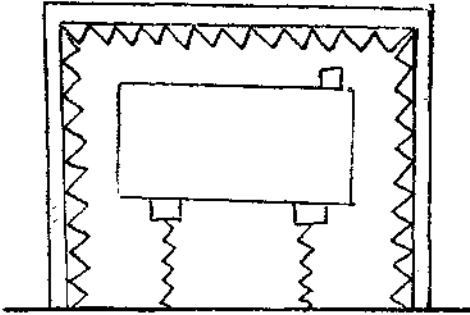

2

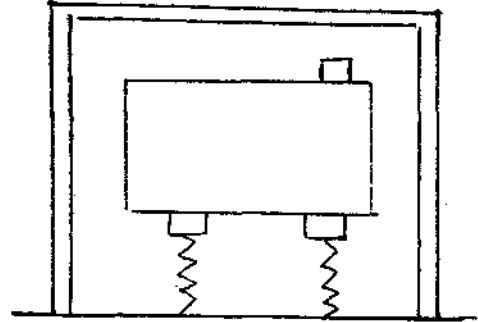

3

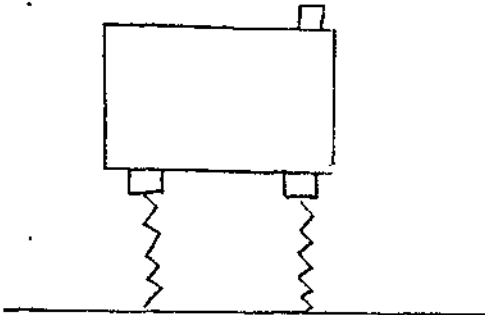

4

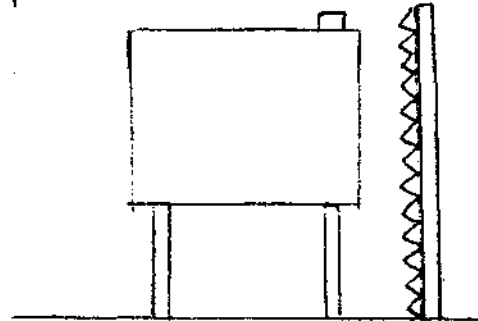

5

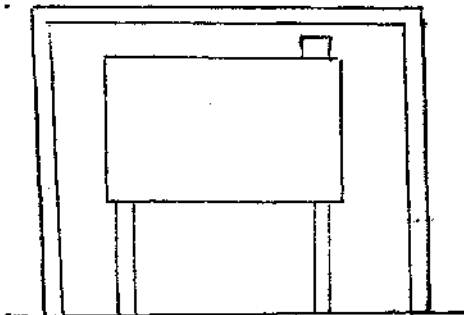

6

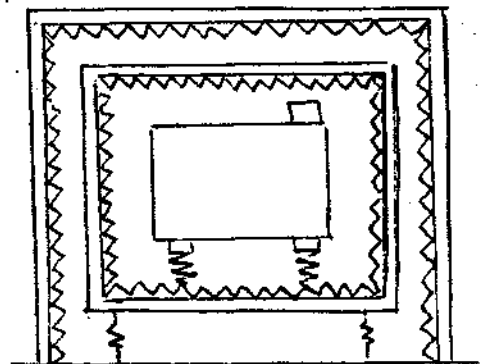

Q.17 Match the frequency ranges of --  
 a) Acoustic lab tests                      b) Hi-fi  
 c) Piano                                        d) Speech  
 e) Hearing range of the old.                f) Hearing range of the young  
 with those on the graph.

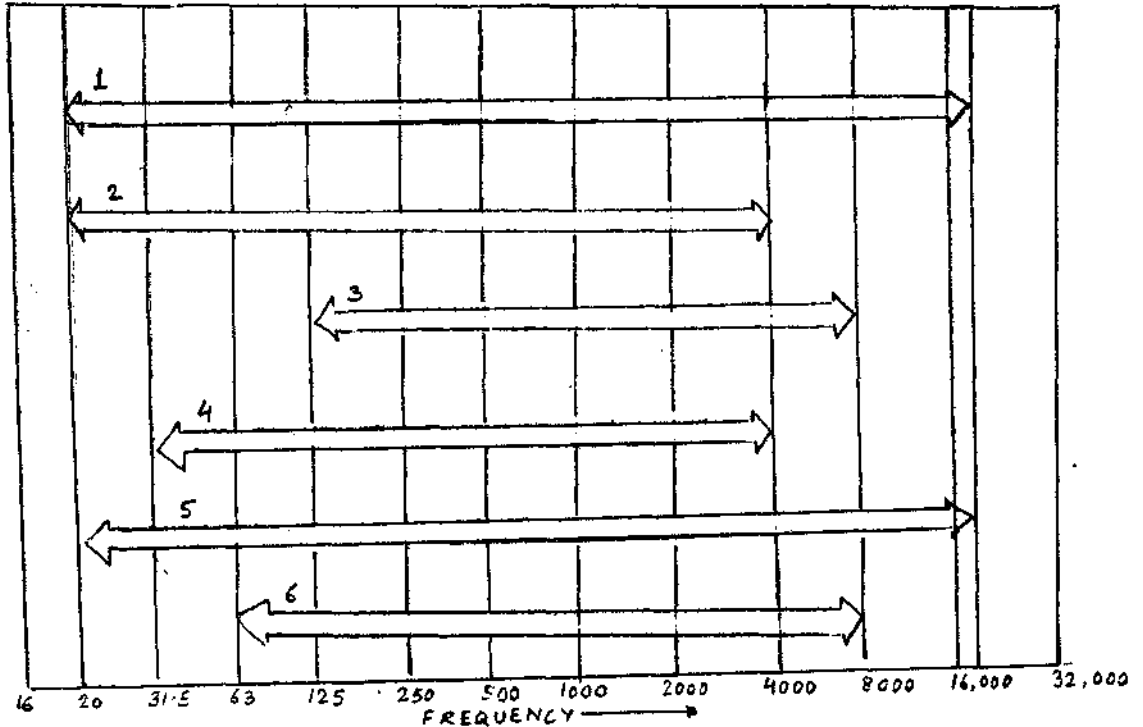

Q.18 Label the graph with the 3 common sources of noise--  
 A) Home vaccum cleaner.  
 B) Electric shaver.  
 C) Airplane.

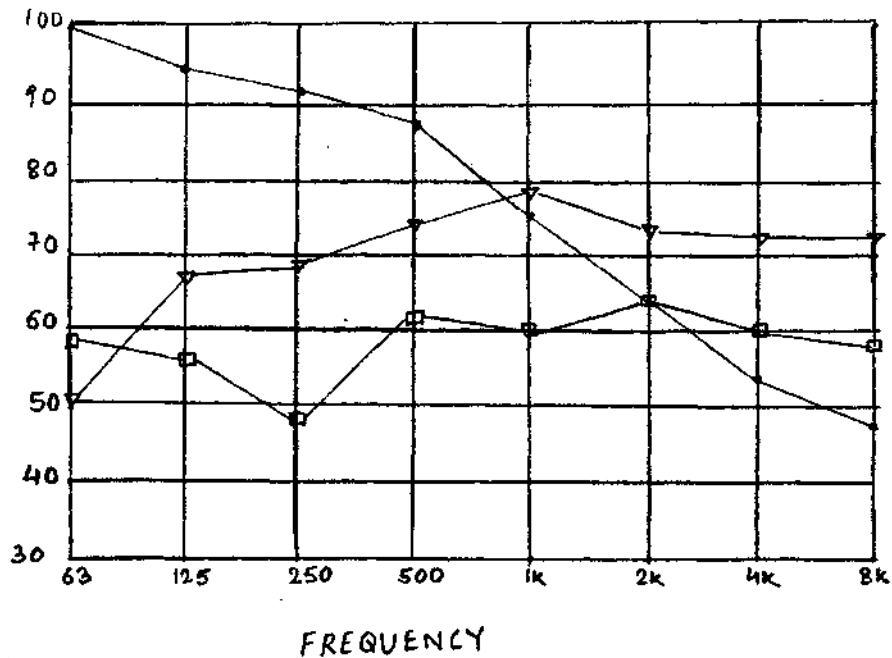

- Q.19 Based on the noise reduction co-efficient of
- 1) Suspended acoustic tile ceiling.
  - 2) Shredded wood fibre board.
  - 3) Carpet.
  - 4) Plaster on brick.

Label the graph.

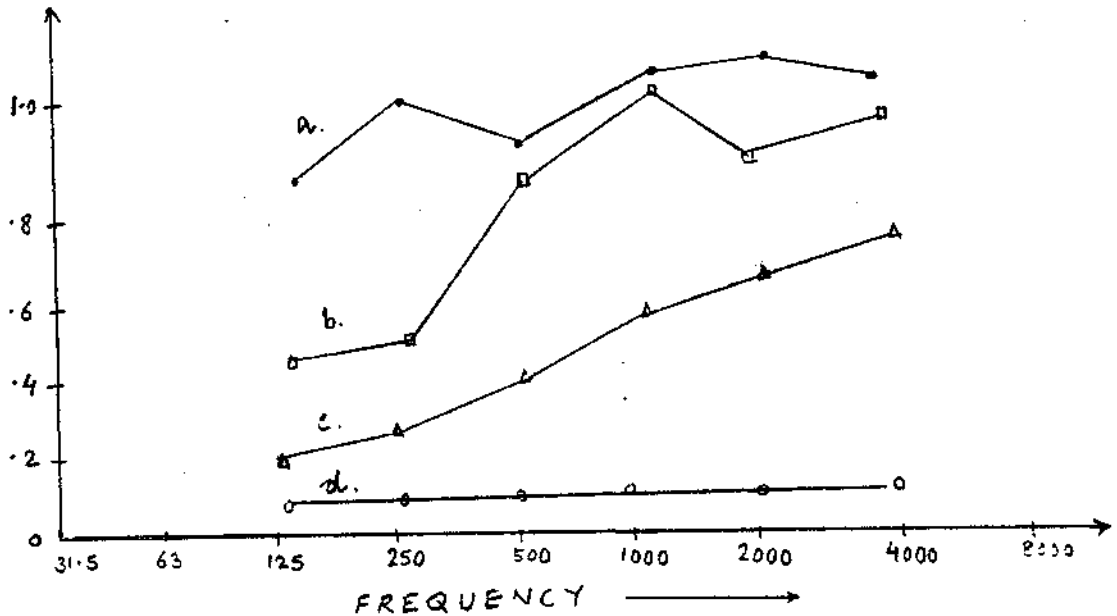

- Q.20 Arrange these materials on the graph in order of minimum to maximum transmission loss-
- (1) Lead (2) Steel (3) Plaster / glass (4) masonry (5) Plywood.

Choose the right order--

- (a) 2, 3, 5, 4, 1 (b) 5, 2, 4, 3, 1 (c) 5, 3, 4, 2, 1

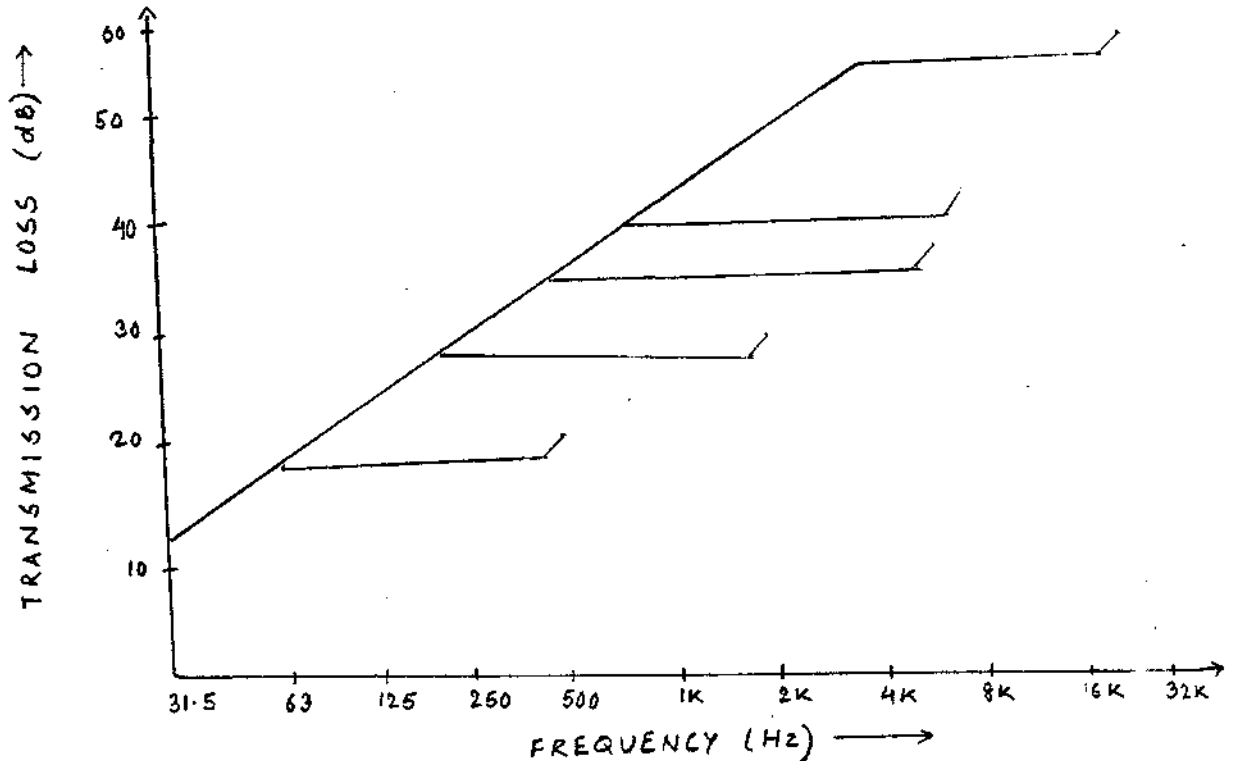

Q.21 Match these commercially available sound absorbing material with their names.

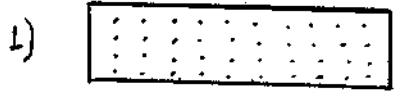

a) Slotted tile / panel



b) Glass fiber blankets boards



c) Regular perforated tile



d) Fissured tile or panel



e) Random perforated tile.



Q.22 A) What do these depict ?

Choose the correct one :-

- a) Acoustic tiles.
- b) Studio walls of different shapes.
- c) Wood fibre boards.
- d) Studio shapes with non-parallel plane surfaces.

B) HOW are they useful ?

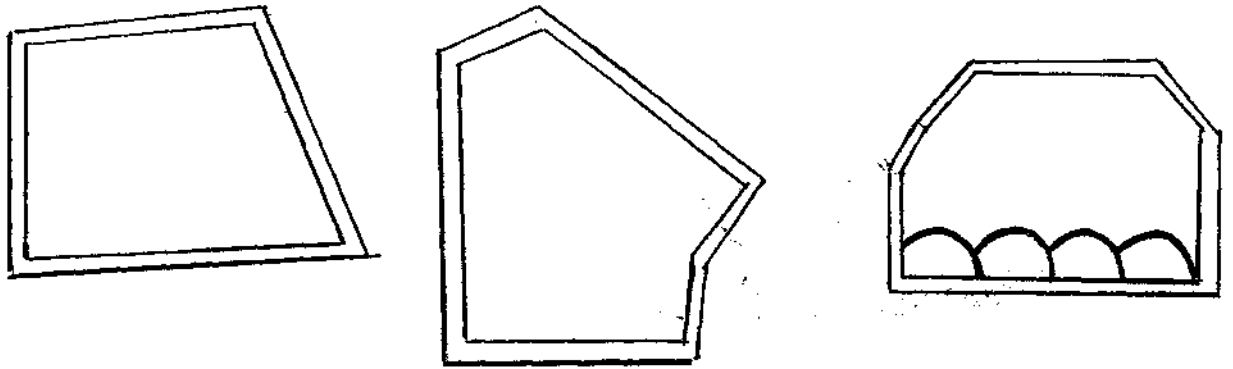

Q.23 If the graph depicts "reverberant SPL" from Sound Power Levels --  
MARK The X and Y axis.

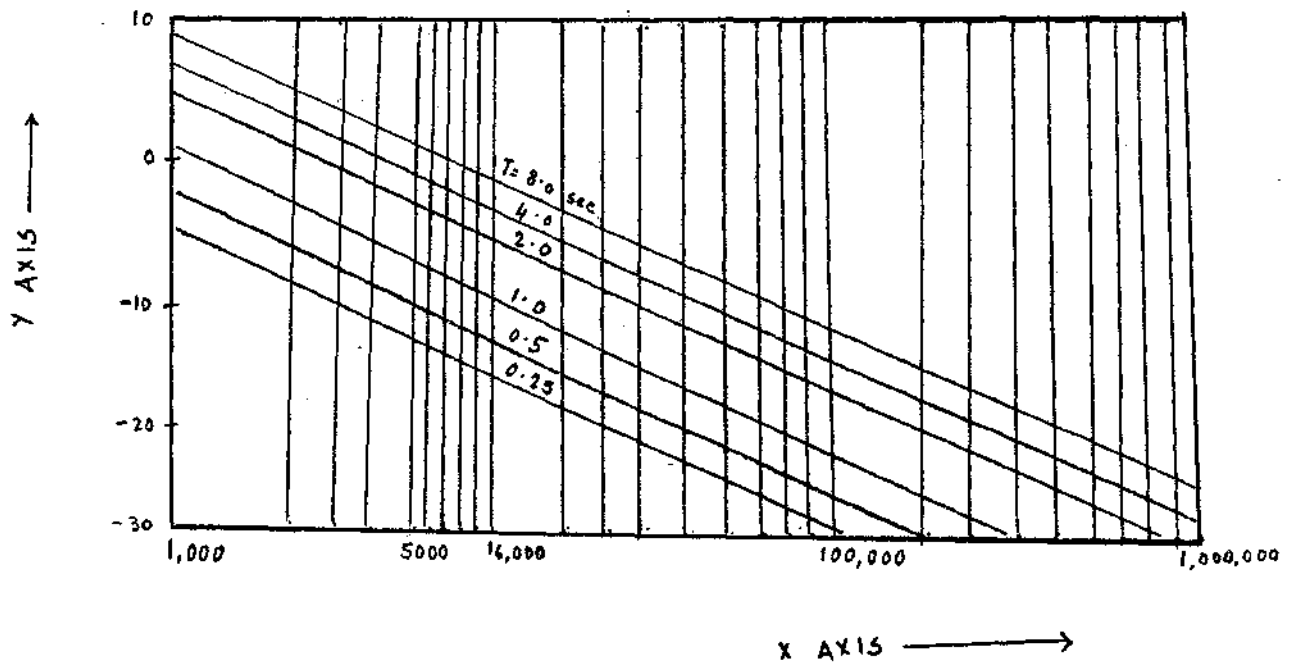

Q.24 What does this graph depict ?

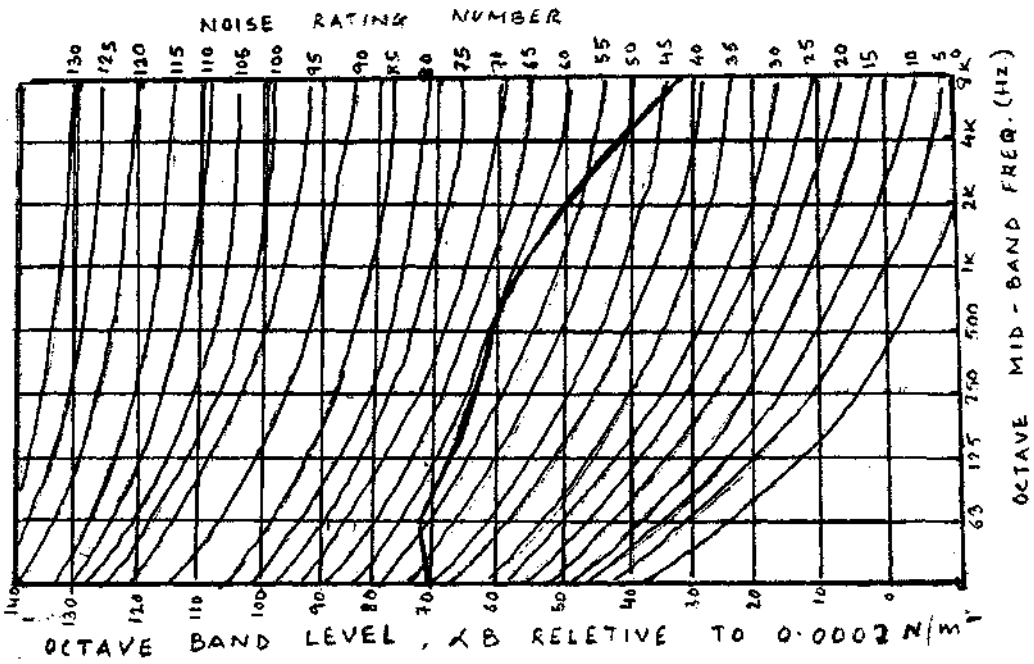

Q.25 a) label a-e on the NOISE CRITERIA CURVE,  
 b) Label the X & Y axis.

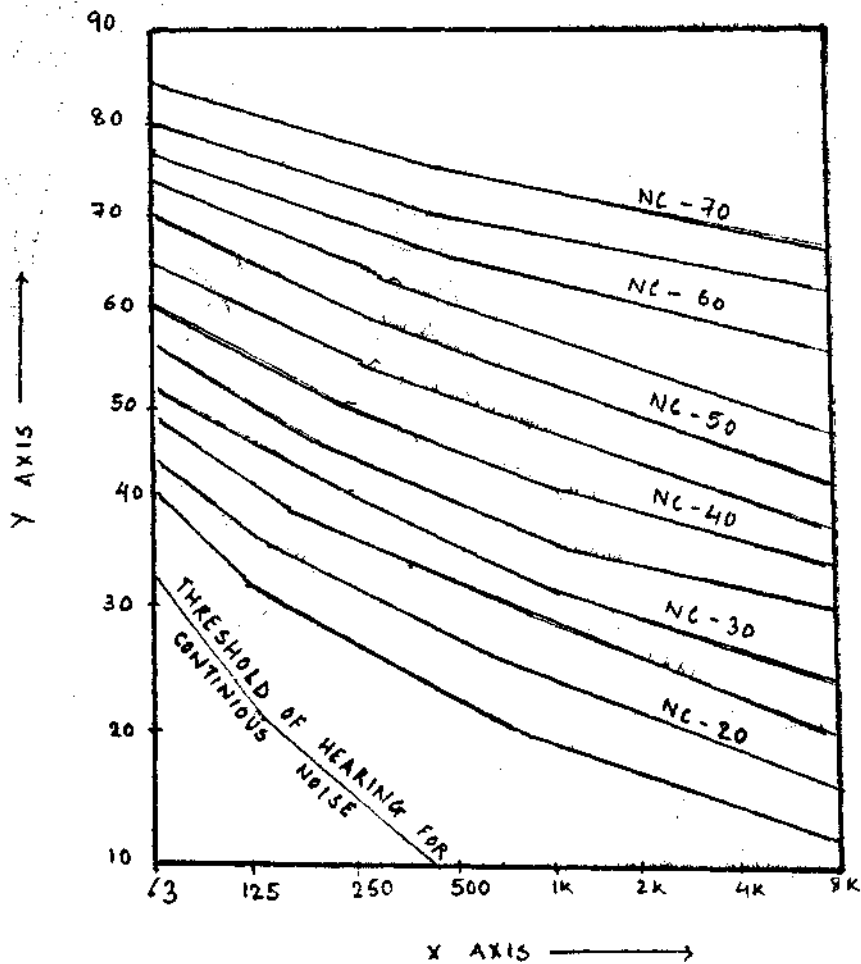

# **ANSWERS**

## ANATOMY, PHYSIOLOGY AND PATHOLOGY

Ans 1 :-

- A - Pinna
  - B - External auditory canal (EAC)
  - C - Malleus
  - D - Tympanic membrane
  - E - Incus
  - F - Stapes
  - G - Semi circular canals
  - H - Cochlea
- 1 - Outer ear
  - 2 - Middle ear
  - 3 - Inner ear

Ans 2 :-

- a) Temporal bone
- b) A - Squamous portion
- B - Zygomatic process
- C - EAM
- D - Tympanic portion
- E - Styloid process
- F - Mastoid process
- G - Mastoid position

Ans 3 :-

- A - Medial Geniculate Body
- B - Inferior-colliculus
- C - Lateral Lemniscus
- D - Dorsal cochlear nucleus
- E - Superior olivary complex
- F - Ventral cochlear nucleus
- G - Auditory nerve.

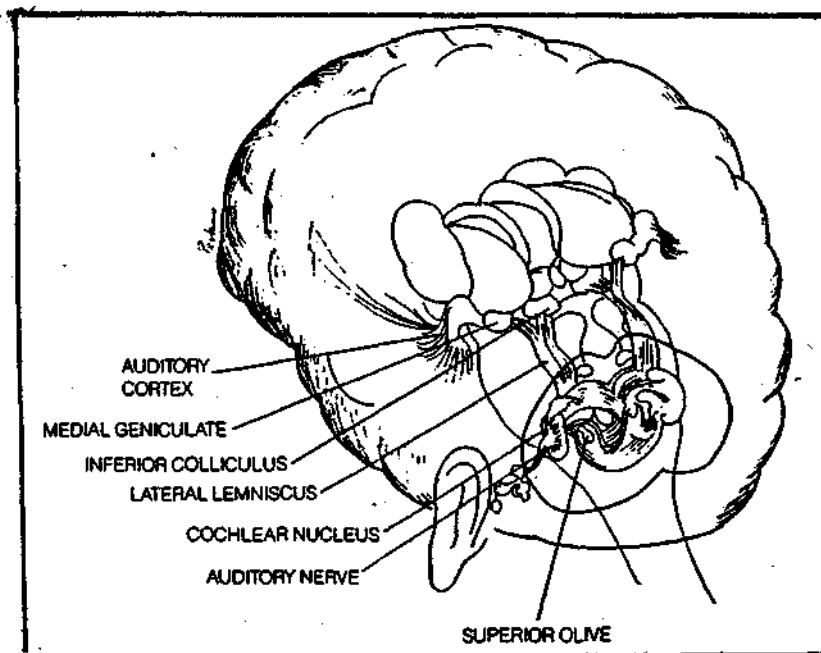

Ans 4 :-

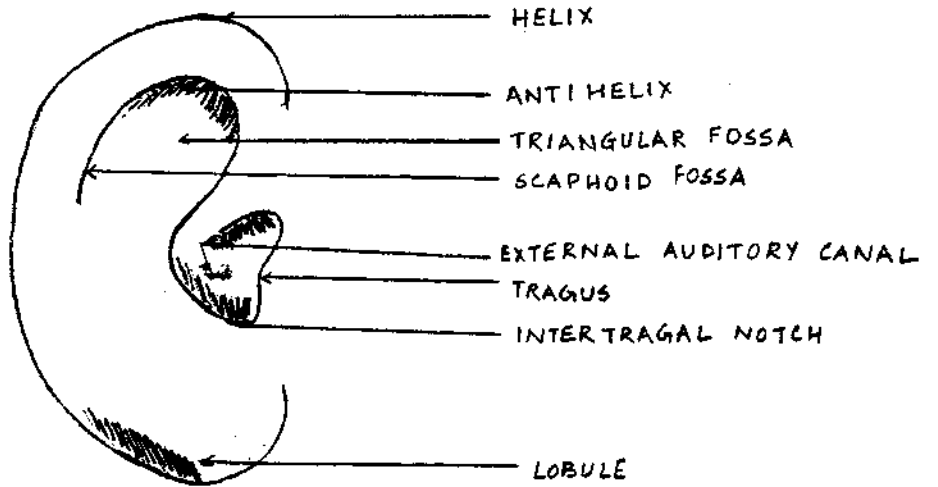

H	B	C	A	S	S	O	F	R	A	L	U	G	N	A	I	R	T	L	T	U
E	X	T	E	R	N	A	L	A	U	D	I	T	O	R	Y	C	A	N	A	L
L	X	M	A	L	T	X	F	H	E	Z	L	T	M	P	Q	R	O	A	C	D
I	B	A	K	O	R	O	N	C	A	T	A	R	P	O	R	E	K	I	H	O
X	S	B	E	K	A	L	K	N	E	R	T	A	B	H	A	L	O	C	H	I
I	L	U	O	T	S	O	M	O	A	R	K	A	M	O	N	A	A	C	H	O
L	T	O	G	U	M	R	A	C	K	A	A	M	O	N	A	A	C	H	O	I
E	A	I	G	A	I	K	A	J	T	A	B	I	S	H	O	N	B	O	A	R
H	I	A	N	G	R	A	A	N	I	F	E	L	O	B	U	L	E	D	U	P
I	R	H	O	A	G	T	A	C	H	I	K	I	N	T	U	K	H	U	B	K
T	O	M	K	A	J	B	I	A	K	I	A	A	C	H	E	T	O	B	H	I
N	S	H	O	N	K	H	A	T	R	A	B	L	A	G	C	H	E	N	A	A
A	I	A	K	T	A	L	I	N	N	E	B	A	K	I	A	A	C	H	E	H
L	O	H	C	T	O	N	L	A	G	A	R	T	R	E	T	N	I	I	G	A

Ans 5 :-

- A - Inner bone perforated by squamous part of temporal bone
- B - Outer cartilage
- C - Perichondrium
- D - Hairs
- E - External auditory meatus
- F - Isthmus
- G - Inner bony part formed by tympanic part of temporal bone.
- H - Narrowest part
- I - Outer skin layer of tympanic membrane
- J - Anterior recess
- K - Periostium

Resonance frequency 3500 Hz

Ans 6 :-

- a) 1 - Posterior horizontal fold  
2 - Attic  
3 - Anterior horizontal fold  
4 - Handle of malleus surmounted by short process  
5 - Umbo  
6 - Cone of light
- b) 1 - Anterior superior  
2 - Posterior superior  
3 - Anterior Inferior  
4 - Posterior Inferior

Ans 7 :-

- a) 2000Hz, amplitude curves.  
b) 4) axis of rotation  
h) Above the resonance frequency

Ans 8 :-

- a) A - Type 1  
B - Type 3a  
C - Type 2  
D - Type 3b

b) Chronic suppurative otitis media

Ans 9 :-

a) schematic representation of the middle ear.

d)

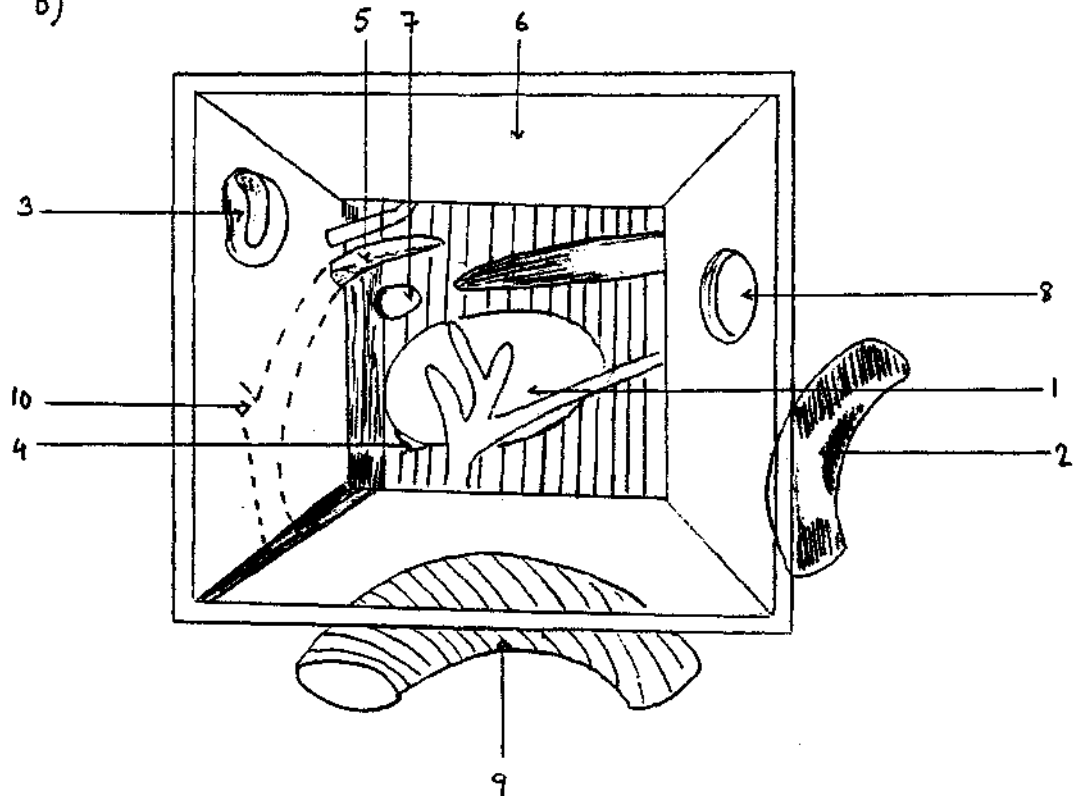

Ans 10 :-

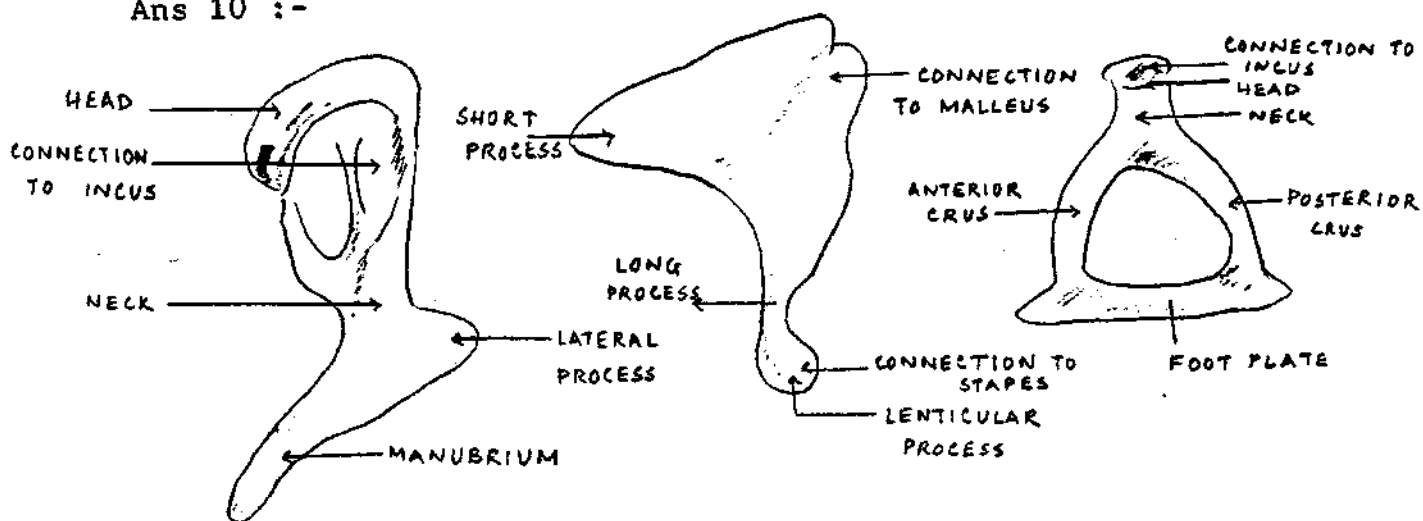

Ans 11 :-

The main direction of ossicular chain movement.

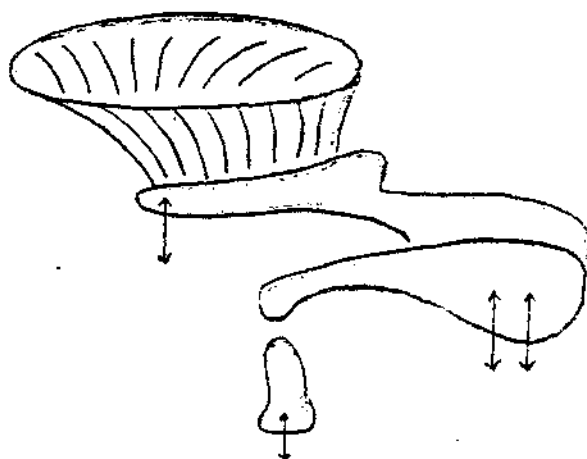

Ans 12 :-

The diagram represents the relation between the tympanic membrane, ossicles of the ME and the Inner ear.

- A- Tympanic membrane
- B- Ossicles
- C- Inner ear.

Ans 13:-

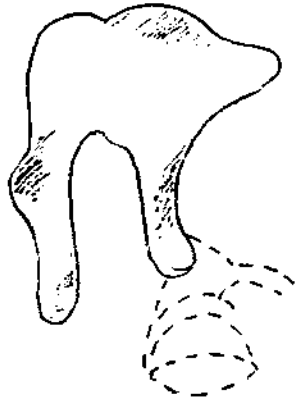

1. Stapes and stapedial muscle absent.

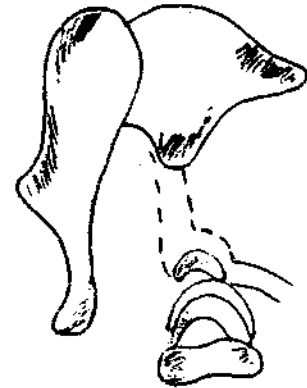

2. Incus lacking entire long cms.



3. Incus lacking short process, stapes and stapedius muscle absent.

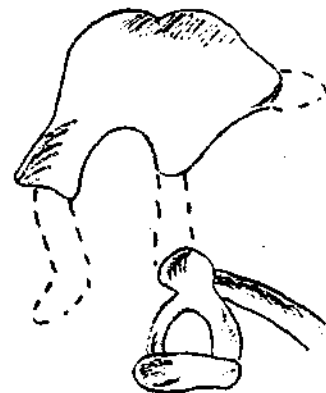

4. Conglomerate of malleus and incus, malleus lacking handle, incus lacking long crus and short process.

Ans 14 :-

- a) i) Bony labyrinth - semi - circular canals
- ii) Oval window
- iii) Round window
- iv) Cochlea
- v) Membraneous labyrinth
- vi) Ampulla
- vii) Utricle
- viii) Saccule
- ix) Cochlear duct

b) Fig. 1 - Bony labyrinth of Inner ear.

Fig. 2 - Membraneous labyrinth of Inner ear.



Ans 15 :-

- a) Modiolar cross-section of the cochlea illustrating the  
scalae through each of the turns.
- b) A - Spiral ligament  
B - Scala vestibuli  
C - Scala tympani  
D - Organ of corti  
E - Auditory nerve  
F - Vestibular branch of the auditory nerve  
G - Helicotrema  
H - Reissner's membrane  
I - Basilar membrane

Ans 16 :-

- a) Scala media is organ of corti
- b) A - 7  
B - 4  
C - 12  
D - 9  
E - 13  
F - 13  
G - 15  
H - 2  
I - 14  
J - 16  
K - 10  
L - 6  
M - 8  
N - 5  
O - 1  
P - 3

Ans .17 :-

- a) Vestibular receptor organs
- b) A - Crista  
B - Macula  
C - Vestibular ganglion  
D - Internal auditory canal

Ans 18 :-

- a) A - Inner hair cells (They are present on the organ  
B - Outer hair cells of corti of the cochlea of the  
inner ear.)
- b) 1 - Streocilia  
2 - Basal body  
3 - Nucleus  
4 - Deiters cells  
5 - Afferent dendrites  
6 - Neural channels

Ans 19 :-

The potentials of the different shaded portions of the cochlea are:-

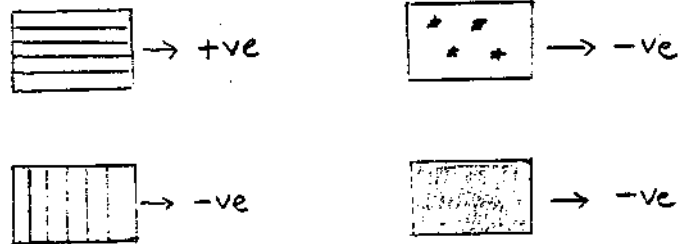

Ans 20 :-

The phenomenon depicted is how **SHEARING ACTION** of the tectorial membrane and the cilia of hair cells is produced.

The fluid motion from the oval to the round window is transmitted through the cochlear duct. As the footplate of the stapes is pushed into the perilymph of the scala vestibuli, the vestibular membrane, is bulged into the cochlear duct, causing movement of the endolymph within the cochlear duct and movement of the basilar membrane. The cilia of the hair cells are embedded in the gelatinous tectorial membrane, so that when the basilar membrane is displaced, there is shearing action on the cilia by the tectorial membrane.

Ans 21 :-

- a) The travelling wave in the cochlea
- b) Von Bekesy

Ans 22 :-

The figure shows, an expansion of the endolymphatic compartment due to excess endolymph resulting in distention of Reissner's membrane.

This is seen in patients with Menieres disease and vestibular neuronitis.

Ans 23 :- Ramsay - Hunt syndrome

Herpes.. Zoster involving the sensory fibers of the 7th cranial nerve presents as vesicles in the concha and is almost always associated with the 7th nerve lower motor neuron paralysis on the same side.

## AUDIOLOGICAL EVALUATION

Ans - 1.

- 1 - d
- 2 - e
- 3 - b
- 4 - a
- 5 - c

Ans - 2

- a - 14
- b - 13
- c - 5.
- d - 14
- e - 15
- f - 8.
- g - 7
- h - 11
- i - 12.
- j - 6
- k - 10
- l. - 1
- m - 3
- n - 3
- o - 2

Ans - 3.

- (a) Audiograms
- (b&c) A - Saucer shaped audiogram seen in functional hearing loss.
- B - Stiffness tilt audiogram.
- C - Mass tilt audiogram; Cholesteatoma, conductive pathology.
- D - Corner audiogram; Viral agents-mumps.
- E - Cookie bite audiogram; Rubella.
- F - Skislope audiogram; ototoxicity; advanced Noise induced hearing aids.
- G - Dome shaped audiogram; Conductive hearing loss.

Ans - 4.

- 1 - Noise induced hearing loss
- 2 - Presbycusis
- 3 - Menier's disease
- 4 - Otosclerosis
- 5 - Hereditary SN hg loss

Ans - 5.

- a) a - Undermasking
- b - Plateau
- c - Overmasking
- b) The graph shows the effects on response to a stimulus in the test **ear**, of masking in the **non** test ear.

Ans - 6.

The graph shows the articulation curves, those obtained for normal hearing subjects using various types of speech material

- (a) ----...Normal sentences
- (b) \_\_\_\_\_- Monosyllabic words
- (c) \_\_\_\_\_Non-sense syllables

Ans - 7.

- a) The graph shows the articulation curves for speech audiometry as determined by pathology
- b) a - normals  
b - conductive hearing loss (mild)  
c - conductive hearing loss (moderate - severe)  
d - cochlear disorders  
e - retrocochlear dysfunction
- c) 1 - Threshold of intelligibility  
2 - Average conversational level

Ans - 8.

- a) The graph depicts an illustration in audiogram, format of speech spectrum.
- b) A - Fundamental frequency range  
B - Main area for vowels  
C - Voiced consonants  
D - Voiceless consonants

Ans - 9.

- A - Type A ; Compliance range 0,8 - 2.00 cms<sup>3</sup> ; Normals.
- B - Type As ; Compliance < 0.3cms<sup>3</sup> ; increased stiffness as in ossicular fixation.
- C - Ad type ; Compliance > 5cms<sup>3</sup> ; ossicular chain discontinuity
- D - Type B ; Equal complainece values over the whole pressure; serous otitis media.
- E - Type C ; Peak shifts to -ve range < -100mm H20, Eustatian tube dysfunction.
- F - Peak to +ve side, early stages of otitis media
- G - D&E type at high frequency probe; seen in normals also; small abnormalities of TM.
- H - E type, Double peak, ossicular chain discontinuity.

Ans - 10.

- 1) Reflex arc
- 2) A - VCN (Ventral cochlear nucleus)  
B - FMN (Facial motor neuron)  
C - SOC (Superior olivary complex)  
D - Inner Ear  
E - Facial nerve  
F - VIII nerve

3)

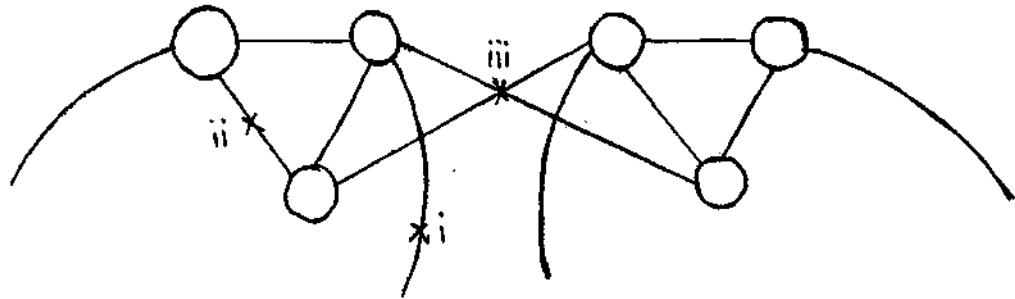

Ans - 11.

1. Impedance Audiometer
2. Jerger
3. i) - 3  
ii) - 1  
iii) - 3  
iv) - 2  
v) - 1  
vi) - 3

Ans - 12.

- a) Tubal function
- b) A - Toynbee Manoeuvre  
B - Valsalva Manoeuvre

Ans - 13.

- a) The diagram depicts the time course of the acoustic reflex in a normal ear and in an otosclerotic ear.
- b) A - Normal  
B - Otosclerotic

Ans - 14.

- a) Reflex decay test.
- b) This is a test of retrocochlear function. In normal subjects a long lasting, high intensity tone (10secs at 10dB above reflex threshold) will maintain normal amplitude throughout stimulation at 500 and 1000Hz)

If there is reduction of amplitude at 50% or more within 5secs. the test is positive. This indicates the presence of a retrocochlear lesion such as VIII nerve tumour or brain stem lesion.

Ans - 15.

- a) Normal audiometrics bilaterally.  
Normal Middle ear pressure.

Reflexes are present within normal limits with contralateral stimulation in the Left ear and ipsilateral in the Right ear. Probe assembly in the Right ear reflexes absent.

Therefore with normal hearing and normal tympanogram on the right side, there is a strong suggestion of an absent right stapedial tendon on central lesion in the efferent reflex arc for the right ear.

- b) Normal results in the right ear, discrepant results for the left ear.

Pure tone and speech audiometrics do not agree Tympanograms reveal normal-, middle ear function. Acoustic reflex threshold are n with contralateral stimulation bilaterally. But, reflex thresholds with left ear stimulation are better than that the admitted behavioural thresholds in the left ear.

Therefore non-organic hearing loss in the left ear.

- c) Left ear normal audiometrics but in the right there is moderate degree of conductive hearing loss.

Tympanogram shows A type in the left ear and reflexes are present at the normal limits. But in the right ear there is Ad type of tympanogram with elevated reflexes.

Therefore ossicular chain discontinuity.

Ans - 16.

- a) Laddergrams  
b) ABLB  
c) 1-b  
2-c  
3-a  
4-d

Ans - 17.

- a) BEKESY AUDIOMETRY  
b) 1) TYPE I 2) TYPE II 3) TYPE III 4) TYPE IV 5) TYPE V  
c) 1) Typical of normal hearing but can be seen in conductive hearing loss and occasionally in Sensory Neural hearing loss (Pesbycusis)  
2) Typical of cochlear disorders associated with recruitment.

- 3) Typical of neural disorders.
- 4) Typical of retrocochlear disorders.
- 5) Often found in non-organic hearing loss or malingering.

Ans - 18.

- a) Central auditory dysfunction.
- b) Staggered spondaic word (SSW) test.

Ans - 19.

a) *NEURO ELECTRIC POTENTIAL TO A BRIEF AUDITORY STIMULUS*

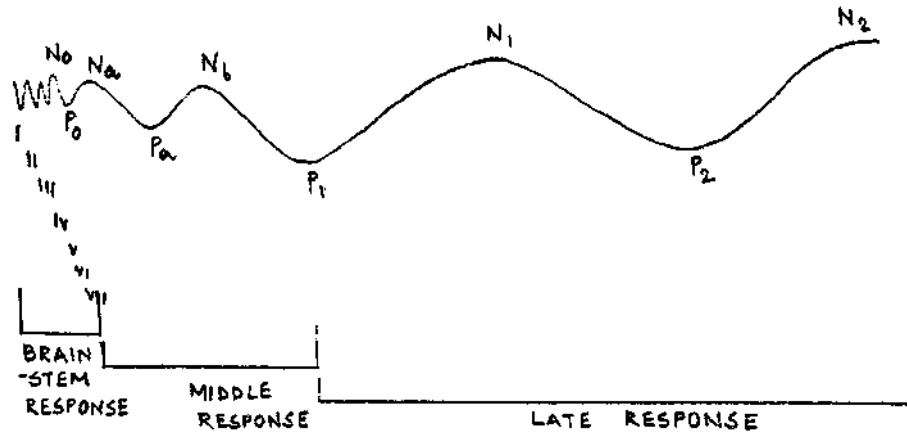

Ans - 20.

- 1-e
- 2-c
- 3-f
- 4-a
- 5-b
- 6-d

Ans - 21.

- a) Brain stem response.
- b) X axis - Intensity (dB); Y axis - Duration (ms).

Ans - 22.

- a-7
- b-4
- c-6
- d-3
- e-2
- f-1
- g-5
- h-8

Ans - 23.

a) Cochlear pathology - Right ear.  
Normal - left ear.

b) Right ear - normal

Left ear - retrocochlear pathology (acoustic nerve tumour)

From the ABR pattern-

Wave II in the left ear shows both prolonged latency and decreased amplitude, while inter peak latency for wave III-V is normal.

Ans - 24.

Click evoked otoacoustic emission.



## INSTRUMENTATION

Ans 1 :-

- a) 1 - pure tone audiometer
- 2 - Speech audiometer
- b) A - Pure tone generator
- B - Amplifier
- C - Attenuator (hearing aid dial)
- D - Air Conduction earphone
- E - Bone Conduction vibrator
- F - Microphone
- G - Phonograph
- H - Tape recorder
- I - Amplifier
- J - Attenuator (Hearing Aid dial)
- K - Auxiliary amplifier
- L - Loudspeaker
- M - Earphones.

Ans 2 :-

- 1 -> **Microphone housing**
- 2 -> **Electrically charge dielectric**
- 3 -> **Sound inlet**
- 4 -> Capacitor bank plate
- 5 -> Capacitor plate diaphragm
- 6 -> Terminals.

Ans 3 :-

- a) 1. A warblet
- 2. Crib - 0 - gram
- b) Paediatric population.

Ans 4 :- Probe of an immittance meter

- A - 220 H oscillator
- B - Potentiometer / attenuator
- C - Loudspeaker
- D - Air pump
- E - Manometer
- F - Balance meter
- G - Reference voltage
- H - Bridge circuit
- I - Amplifier
- J - Microphone

Ans 5 :-

- A -> **Sound**
- B -> Microphone
- C -> Pressure

Ans 6 :-

- a) Brainstem auditory evoked potentials instrument.
- b) A - The signal generating component.
- B - Computer averager component
- C - The amplifier and filter components.

Ans 7 :-

- a) Oto-acoustic emission (OAE)
- b) Fig 1 - spectral analyser  
Fig 2 - A - Transducer  
          B - Time Domain Averaging
- c) Fig 1 is used for the measurement of spontaneous OAE from human ears.  
Fig 2 is a schematic diagram of a representative system for the measurement of transient evoked OAE.

Ans 8 :-

- a) 4 transistor hearing aid, adaptive noise rejection circuit.
- b) Computer based adaptive noise rejection circuit is added to a standard hearing aid circuit to reduce noise component.
- c) A. Cell  
      B. DC  
      C. Ground  
      D. Microphone  
      E. Volume control  
      F. Earphone

Ans 9 :-

- a) Fig 1 - bone conduction hearing aid receiver  
Fig 2 - dynamic or moving coil type receiver
- b) Fig 1 - the bone conduction receiver is simply another version of the magnetic receiver so as to produce vibrations rather than sound waves.

Fig 2 - A receiver little used with hearing aids but which might offer excellent quality of reproduction. It eliminates most of the resonances found in poor magnetic type receivers and provides a smooth, even, undistorted sound reproduction.

Ans 10 :-

- i) Socket
- ii) Sealing wax
- iii) Paper outer shell
- iv) Zinc can (outer electrode)
- v) Paper liner
- vi) Chemical mix
- vii) Carbon center electrode
- viii) Paper bottom liner

Ans 11 :-

- a) Electro Acoustic performance
- b) A - monitoring amplifier  
B - loud speaker  
C - monitoring microphone  
D - Hearing aid  
E - Hearing aid earphone  
F - 2cc acoustic coupler  
G - Measuring microphone  
H - measuring amplifier  
I - Distortion measurement equipment

Ans 12 :-

- a) Control of Acoustic output
- b) A - Peak clipping circuit  
B - AGC circuit  
C - AGC circuit

i) Circuit → It is a normal position of peak clipping circuit and its effect on a speech like wave form.

ii) AGC circuit with the gain control inside the feed back loop.

iii) AGC circuit with the gain control after the feed back loop.

- c) i - a  
ii - c  
iii - b

Ans 13 :-

a) The schematic diagram represents the FM transmission system feeding to head phone.

- b) 2 - FM transmitter  
1 - Microphone  
3 - Antenna  
4 - FM receiver  
5 - Headphone

Ans 14 :-

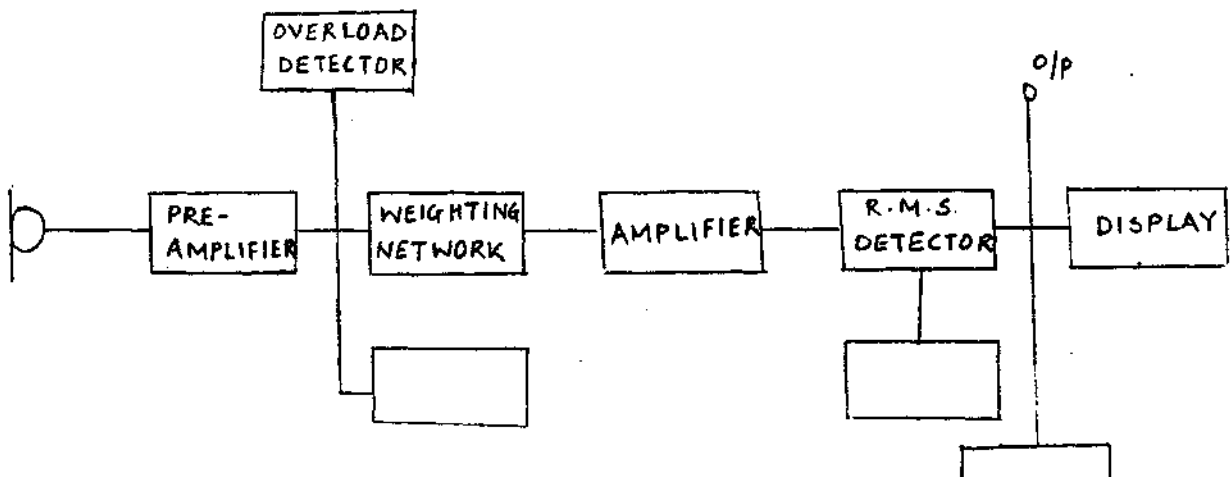



## HEARING AIDS AND ASSISTIVE LISTENING DEVICES

Ans - 1.

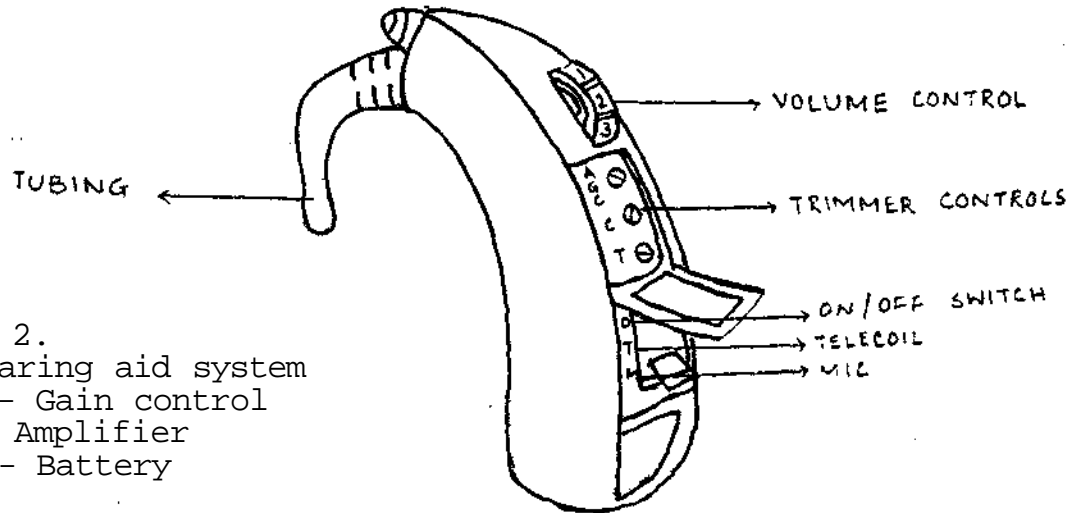

Ans - 2.

- a) Hearing aid system
- b) A - Gain control  
B- Amplifier  
C - Battery

Ans - 3.

- a) Hearing aids
- b)
  1. Post-aural aid
  2. In-the ear Hearing aids
  3. In the canal Hearing aids
  4. Airconduction spectacle aid
  5. CROS aid
  6. Bone conduction spectacle aid
  7. Body level hearing aid
- c)
  1. Can be used for any degree of hearing loss.
  2. Mild - moderate hearing losses.
  3. Mild - moderate hearing losses.
  4. Can be used for any degree of hearing loss.
  5. Till severe - pro-found unilateral hearing loss.
  6. Bone conduction threshold should not be worse than 40 dB.
  7. Till severe to profound hearing loss.

Ans - 4.

- a) An input - output graph for peak-clipping and compression
- b) \_\_\_\_\_ (A) \_\_\_\_\_> Peak clipping  
\_\_\_\_\_ (B) \_\_\_\_\_> Compression

Ans - 5. Frequency response characteristics.

- Ans - 6A - Hearing aid for Right ear using 'S' cord.
- B - Binaural body level aid
- C - BI-CROS
- D - HICROS

Ans - 7.

- a) Receiver ear mold.
- b) 1 - Snap Ring
- 2 - Receiver Base
- 3 - Sound Bore

Ans - 8.

- a) 1 - Receiver mold
  - 2 - 3/4 Skeleton mold
  - 3 - Skeleton mold
  - 4 - Shell mold
  - 5 - Semi-skeleton mold
  - 6 - Canal mold
- b) 1 - Receiver mold is used on both body and ear level hearing aids with an external receiver.
- 2,3,5, - It is used with moderate gain instruments.
- 4 - Used for hearing aids with internal receivers when fitting very high gain hearing aids.
- 6 - It is used for moderate gain instruments.

Ans - 9.

- a) Acoustic modifier.
- b) The graph signifies various acoustic modifications. Venting affects the low frequency region, filters smooth peaks in the response and horns extend the high frequency amplification.

Ans - 10.

- a) CROS Hearing aid (Contralateral routing of signals)
- b) A - Receiver
- B - Battery
- C - Polyvinyl tube
- D - Amplifier
- E - Microphone
- F - Connecting wire
- G - Open ear mold

Ans - 11.

- a) FROS - Frontal Routing of Signals.
- b) 1 - C
- 2 - A
- 3 - B

Ans - 12.

a) 2cc reference coupler

b)

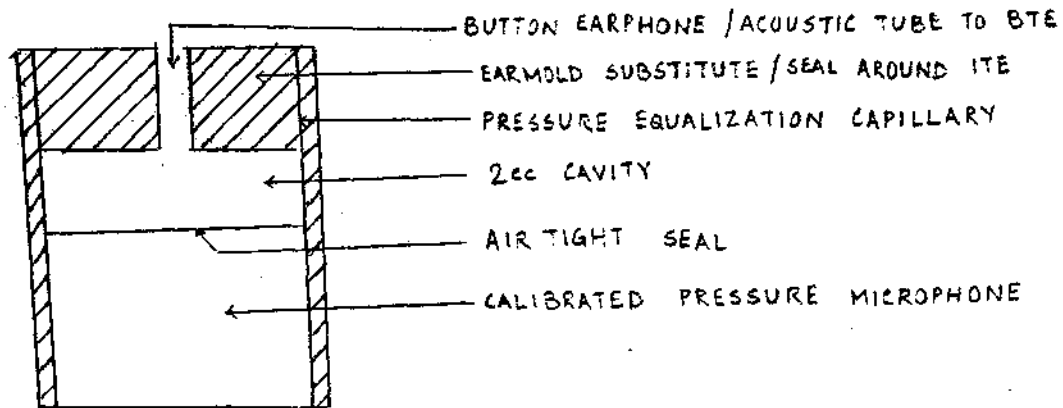

Ans - 13.

A - 2cc reference coupler

B - Insert ear stimulator

C - KEMAR

Ans - 14.

a) Insertion gain

b) ii - 3,1,2

c) (3) - After calibrating the test room, the user sits facing the loudspeaker and a probe tube is inserted into the canal for about 1 1/2 cms.

(1) - A warble tone is presented in a sweep sequence over all test frequencies and sound level is recorded.

(2) - The Hearing aid is then placed in position in the canal without moving the probe tube. The input sounds are presented again and the sound level in the canal is re-measured.

Ans - 15.

a) Post aural aid in a hearing aid test box.

b) A - Oscillator

B - Amplifier

C - Loudspeaker

D - Test space

E - Acoustic coupler

F - Calibrated microphone

G - Control microphone

H - Sound Level Meter and recording device

I - Hearing aid

Ans - 16.

a) The diagrams represent the probe-tube acoustic measurement of real-ear-gain of an in-the-ear (ITE) hearing aid in place.

b) The importance of this measurement is to get a real-ear-gain of a hearing aid.

The first measurement involves placement of the tube in the External auditory canal as close to the tympanic membrane as possible. Then frequency specific signals are presented in the sound field and measured at the Tympanic membrane. Then without removing the tube hearing aid is placed in the canal on top of the tube. The difference in dB between these two conditions, is then an acoustic determination of the real-ear-gain of the hearing aid.

Ans - 17.

- A - Maximum SSPL-90
- B - SSPL-90 curve
- C - Frequency response curve

Ans - 18.

a) Programmable hearing operating system.  
All data concerning the patient's hearing such as threshold, dynamic range, discomfort level etc. are put into the main unit, after which accurate and reproducible values are set for all hearing aid parameters and the settings are down loaded via the programmable cable to the IC within the aid.

b) Advantages:-

1. The aid can be programmed time after time according to the growing needs of the patient.
2. Insertion gain techniques and sp.description tests can be carried out during the same session to verify settings. This is very time saving.
3. The patient can give his immediate impression on sound quality and ease of listening conditions.

Ans - 19.

- a) Cochlear Implant Device
- b) 1 - Microphone headset
- 2 - Twenty-two electrode Array
- 3 - Receiver/stimulator
- 4 - Speech Processor

Ans - 20.

This is an implantation of a multi electrode array of a cochlear implant device.

The multi electrodes cochlear implant uses many channels hence provides better speech recognition than can be obtained with systems employing fewer channels.



Ans - 21.

- a) Class Room amplification systems.
- b) A - Hard wire system
  - B - FM system
  - C - Loop induction amplification system
  
- 1 - Balance control
- 2 - Hard wire
- 3 - Amplifier
- 4 - Input
- 5 - Antenna
- 6 - Headphone
- 7 - Receiver
- 8 - Transmitter
- 9 - Loop
- 10 - Personal hearing aid
- 11 - Induction coil
- 12 - Microphone
- 13 - AMPLIFIER AND OTHER ELECTRICAL CIRCUITRY

Ans - 22.

- a) Lip reading
- b) UPTON'S EYE GLASS/ Lip reading aid of upton

Ans - 23.

- a) Loop Induction system
- b) (i) Clover Leaf system
- (ii) Mono axial system

Ans - 24.

- A - Strap on telephone amplifier
- B - Telephone communication devices
- C - Binaural headset which receives infrared carrier signal (this device can be used for interpersonal communication or in listening to the television).
- D - Paging device with receiver designed to be worn on the wrist to alert the hearing impaired individuals to sounds such as door bell.
- E - Smoke detector which both sounds a loud alarm and illuminates a powerful strobe light.

## NOISE

Ans - 1

The graph represents - variations in pressure caused by speech, music or noise (complex sound waves).

Ans - 2 .

The graph represents the frequency vs Intensity ranges of speech (A), Music, (B), and Audible range (C).

Ans - 3.

- a) A - Pure tone
- B - Square wave
- C - Train of pulse
- D - Single pulse
- E - White noise
- F - Short tone

- b) A - 3
- B - 6
- C - 1
- D - 2
- E - 4
- F - 5

Ans - 4.

- a) The graph depicts - equal loudness contours showing the relationship between loudness level (in phons) and intensity (in dB).
- b) X axis - frequency (in HZ)
- Y axis - Intensity level (dB)
- \_\_\_\_\_ (dotted line) - MAF curve

The loudness levels \_\_\_\_\_ > from 0-120 upwards.

Ans - 5.

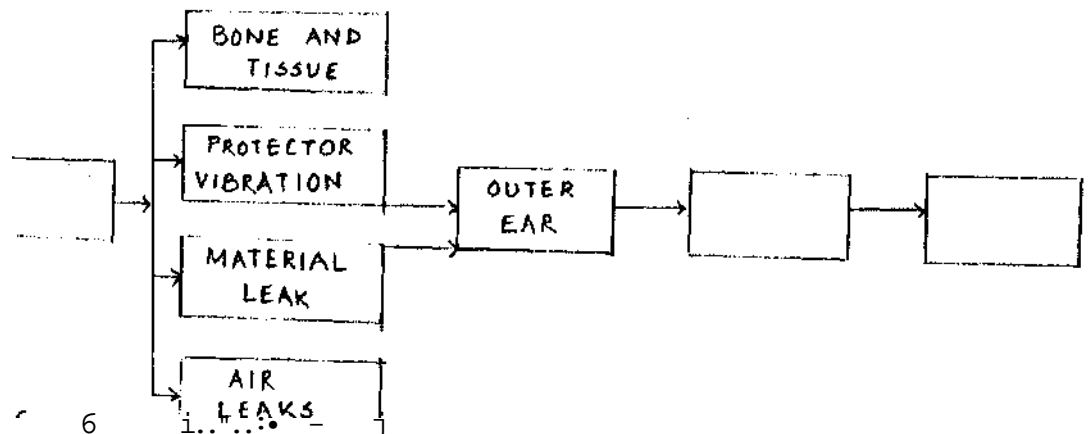

Ans - 6

- a) Cochlea
- b) Loss of hair cells
- c) Exposure to noise

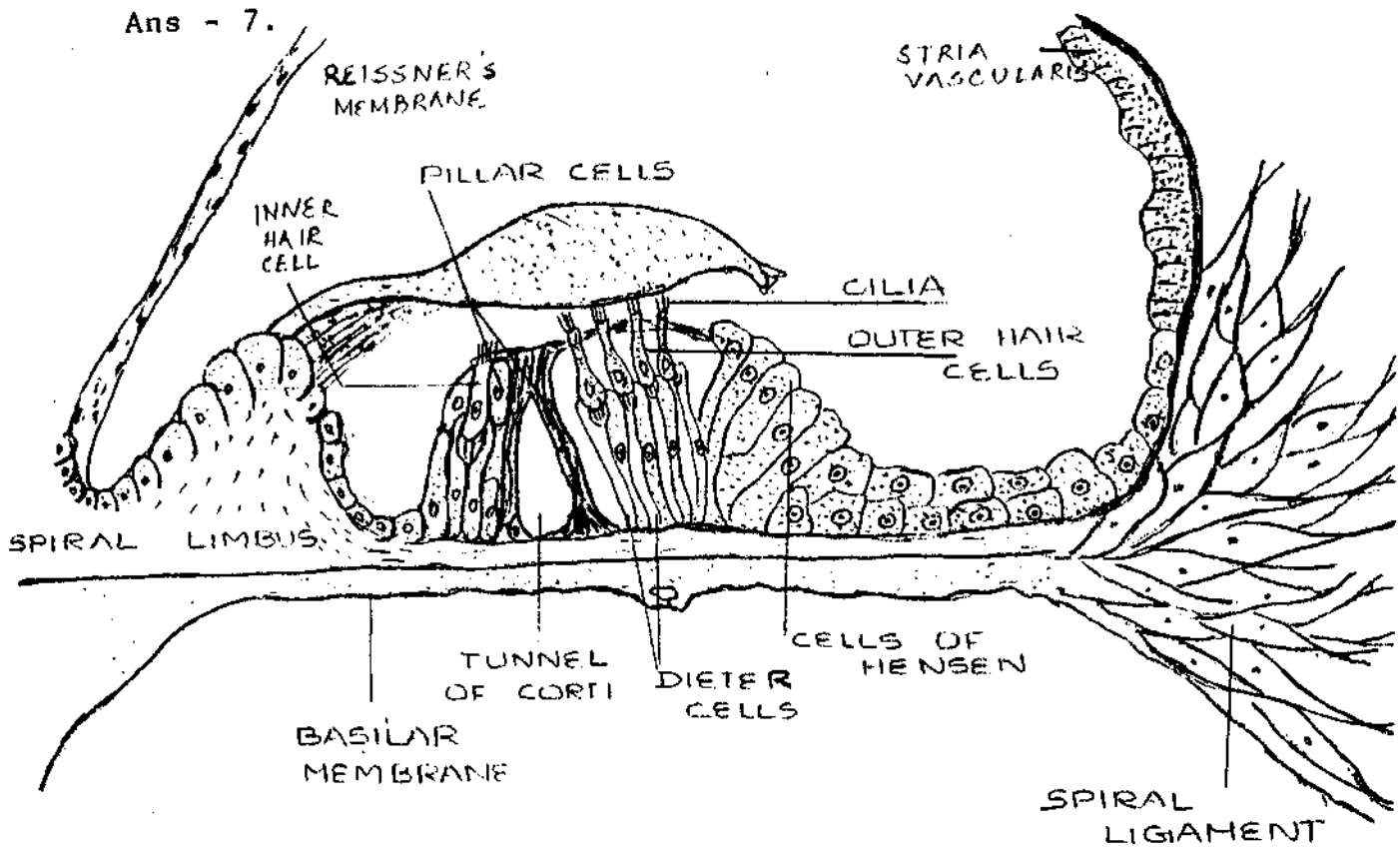

L	L	E	C	R	I	A	H	R	E	N	N	I	D	U	E	S	P	I	S	O
S	A	L	L	E	C	R	E	T	I	R	E	D	S	I	S	P	I	R	A	L
I	R	U	A	V	A	N	I	A	N	A	M	O	N	N	Y	E	L	L	E	C
R	D	M	A	N	A	N	D	I	L	C	O	C	C	E	A	M	A	D	A	G
A	N	O	N	I	S	N	A	L	O	M	N	S	E	S	E	L	V	L	L	A
L	C	H	A	N	S	U	M	A	L	U	E	S	S	O	V	L	E	R	R	A
U	C	O	S	K	P	O	D	I	N	Z	E	S	M	U	U	L	P	L	A	S
S	A	V	A	I	M	E	T	C	I	L	L	C	I	T	O	P	L	R	A	L
A	I	R	T	S	P	L	W	C	I	E	S	H	L	E	D	R	I	L	L	A
S	D	E	N	D	O	P	L	A	S	M	I	C	R	E	T	I	C	M	U	L
H	R	E	A	E	N	A	R	B	M	E	M	S	R	E	N	S	S	I	E	R
S	E	T	I	C	R	D	N	E	D	N	L	L	E	C	R	A	L	L	I	P
S	I	E	C	N	E	N	I	M	O	R	P	L	A	R	I	P	S	U	D	E
U	T	S	O	E	T	A	M	L	L	E	L	E	R	I	A	H	R	E	T	U

Ans - 8.

Typical audiogram of Noised Induced hearing loss is 'B'.

Ans - 9.

a) Sound Level Meter (SLM)

A Sound Level Meter is a sensitive electrical instrument which measures noise and vibrations for health protection and is also used for audiometric calibration.

b) A - Microphone

B - Dial

C - Meter light

D - Indicating meter

E - Output socket

F - Pilot lamp

G - Sensitivity adjustment

H - Filter Input

I - Filter Output

Ans - 10.

a) Sound level meter

b) 1. Wind shield - When readings are taken out of doors in wind the aerodynamic noise due to wind may be as great as 5-10dB. Therefore, a wind shield is used to minimize the extraneous noise.

2. Octave filter set - This is useful if speech interference levels are to be compared, if noise rating curves are to be used, if a particular noise source is to be identified or the annoying components in the noise identified.

3. Piston phone - The SLM should be acoustically calibrated before and after every series of readings. The pistonphone is a self-contained unit for making accurate field calibrations on microphones and generate a precise Sound Pressure Level.

Ans - 11.

The graph represents the -

"FREQUENCY RESPONSE CHARACTERISTICS OF SOUND LEVEL METER".

Ans - 12.

a) The graph represents OSHA's allowable exposure period to noise. (Every 5dB increase in Sensation Level (SL) there is halving of the allowable exposure period).

b) OSHA

Ans - 13.

a) Ear protective devices

b) 1. Molded earplugs

2. Malleable earplugs

3. Muff type earprotectors

Ans - 14.

a) Attenuation in dB.

b) \_\_\_\_\_> Attenuation of ear muffs.

\_\_\_\_\_> Attenuation of ear plugs.

\_\_\_\_\_> Attenuation of  
combination of muffs and plugs.

Ans - 15.

A) d - Noise dosi meter.

B) Noise dosi meters are integrating sound meters that operate over fixed time periods, usually 8 hrs. They convert dBA level to frequency in accordance with the OSHA dBA/ exposure time relationship and produce a composite exposure number on a digital readout.

Ans - 16.

a) Noise and Vibrations

b) C - 3,4,5,2,1,6 .

Ans - 17.

A - 6

B - 5

C - 4

D - 3

E - 2

F - 1

Ans - 18.

A - 2

B - 3

C - 1

Ans - 19.

1 - a

2 - b

3 - c

4 - d

Ans - 20.

c) 5,3,4,2,1 (min to max transmission loss).

Ans - 21.

1 - c

2 - e

3 - a

4 - b

5- d

Ans - 22.

a) These depict -

(d) Studio shapes with non-parallel plane surfaces.

b) Sound behaves like light, its angle of incidence is equal to its angle of reflection. If a studio has parallel walls, sound waves reflect into each other creating

standing waves. If they are concave surfaces, they serve as collecting points, generating unwanted concentration of sound. A studio should be designed to break up the paths of sound waves to prevent building momentum.

Ans - 23.

X axis - Room Volume in Cu ft.

Y axis - Reverberant SPL - PWL in dB (re:  $10^{-12}$  watt).

Ans - 24. The graph depicts 'NOISE RATING CURVES'.

The noise levels which can be considered to be acceptable in an occupied space such as a flat, house, factory, etc. will depend on the activities to be carried out in that space.

Noise Rating Curves enable this acceptability to be assessed. They weigh each part of the frequency spectrum, take into account the sensitivity of the ear to different frequency and assess annoyance factors, speech interference levels and loudness levels.

Ans - 25.

a) a - Very quiet

b - Quiet

c - Moderately noisy

d- Noisy

e - Very noisy

b) X axis - Octane band center freq in Hz.

Y axis - Sound pressure level in dB.

## BIBLIOGRAPHY

- Alten, S.R., (1981), Audio In Media , Baltimore : Wordsworth.
- Arlinger, S., (1991), Manual of Practical Audiometry, London and New Jersey : Whurr.
- Ballantyne, D., (1990), Handbook Of Audiological Techniques, London : Butterworth - Heinemann.
- Berger, K.W., And Millin, J.P., (1978), Hearing Aids, in Rose, D.E., (Ed), Audiological Assessment, New Jersey : Prentice - Hall Inc. Englewood.
- Bess, F.H., And Humes, L.E., (1990), Audiology The Fundamentals, Baltimore : Williams And Wilkins.
- Bess, F.H., And Logan, S.A., (1984), Amplification in the Educational Setting, in Jerger, J., (Ed), Paediatric Audiology 2. Current Trends, San Diego, California T College Hill Press.
- Boies, L.R., (1950), Fundamentals of Otolaryngology, Philadelphia : W.B.Sunder's Company.
- Browning, G., (1986), Clinical Otology and Audiology, London: Butterworths.
- Brunt, M.A., (1994), Tests of Cochlear Function, in Katz, J., (Ed), Handbook of Clinical Audiology, Baltimore: Williams And Wilkins.
- Cheremisinoff, P.N., Cheremisinoff, P.P., et. al., (1978), Industrial Noise Control Handbook, Michigan : Ann Arbor Science.
- Duerden, C., (1970), Noise Abatement. London : Butterworths.
- Egan, D.M., (1972), Concepts In Architectural Acoustics, New York : McGraw-Hill Book Company.
- Ferraro, J.A., And Durrant, J.D., (1994), Auditory Evoked Potentials : Overview and Basic Principles, in Katz, J., (Ed), Handbook of Clinical Audiology, Baltimore : Williams And Wilkins.
- Gelfand, S.A., (1981), Hearing : An Introduction To Psychological And Physiological Acoustic! New York : Marcel Dekker, Inc.
- Goodhill, V., (1979), Ear-Disease, Deafness And Dizziness, New York : Harper And Row.

- Goodhill, V., Guggenheim, P., **et.al.**, (1971), **Pathology, Diagnosis and Therapy of Deafness**, in Travis, L.E., (Ed), Handbook of Speech Pathology and Audiology, New York : Appleton - Centruy-Crafts.
- Gullick, W.L., Gescheider, G.A., et al, (1989), Hearing : Physiological Acoustics, Neural Coding and Psychoacoustics, New York : Oxford University Pres.
- Hirish, I.J., (1952), The ueasurement of Hearing, New York : Me Graw-Hill Book Company.
- Kahene, J.C, and John, F.F. , (1984), Atlas of Speech and Hearing Anatomy, Colombus, Ohio : Charles E Merrill A Bell and Howell Company.
- Kaplan, H., Gladstone, V.S. et.al., (1993), Audiometric Interpretation A Manual of Basic Audiometry, Boston : Allyn and Bacon.
- Luxon, L.M., (1987), Physiology of Equilibrium and Its Application in the Giddy Patient, in Wright, D., (Ed), Scott -Brown\* s Otolaryngology ^ Basic Sciences, London : Butterworths.
- Martin, F.N., (1991), Introduction to Audiology, New Jersey : Prentice Hall.
- Martin, M.C., (1981), Hearing Aids, in Beagley, H.A., (Ed), Audiology and Audiological Medicine, New York :Oxford University Press.
- Mc.Candless, G.A., (1978), Neuroelectric Measures of Auditory Function, in Rose, D.E.(Ed), Audiological Assessment, New Jersey: Prentice-Hall Inc Englewood Cliffs.
- Nager, G.T., (1973), Congential Aural Atresia : Anatomy and Surgical Management, in Paparella, M.M., and Shumerick, D.A., (Ed), Otolaryngology - Ear, Philadelphia : WB Saunders Company.
- Northern, J.L., and Gabbard, S.A., (1994), The Acoustic Reflex, In Katz, J. (Ed), Handbook of Clinical Audiology, Baltimore : Williams And Wilkins.
- Norton, S.J., And Stover, L.J., (1994), Otaacoustic Emission - An Emerging Clinical Tool, in Katz, J., (Ed), Handbook of Clinical Audiology, Baltimore : Williams and Wilkins.
- Padmaja, B., (1987), Audiologists ! It is Quiz Time With Visuals, Unpublished Masters Independent Project, University of Mysore, Mysore.



- Pickles, J.D., (1987), Physiology of the Ear, In Wright, D., (Ed), Scott Browns Otolaryngology j^ Basic Sciences, London : Butterworths.
- Pulec, J.L., And Horwitz, M.J., (1973), Diseases of the Eustatian Tube, in Paparella, M.M., And Shumerick, D.A., (Ed), Otolaryngology-Ear, Philadelphia : W.B.Saunders Company.
- Risberg.A., (1969), A Critical Review of Work on Speech Analyzing Hearing Aids, in Levitt, ll., Pickett, J.M. et.al., (Ed), Sensory Aids for the Hearing Impaired : The Institute of Electrical and Electronics Engineers.
- Sataloff.J., And Michael,P., (1973), Hearing Conservation, Springfield : Charles. C Thomas Publisher.
- Silman, S., And Silverman, C.A., (1991), Auditory Diagnosis Principles and Applications, San Diego : Academic Press.
- Staab, N.J., and Lybarger, S.F., (1994), Characteristics and Use of Hearing Aids, in Katz, J., (Ed), Hand book of Clinical Audiology, Baltimore : Williams and Wilkins.
- Tate, M., (1994), Principles of Hearing Aid Audiology, London : Chapman and Hall.
- Watson, L.A., and Tolan, T., (1949), Hearing Tests and Hearing Instruments, Baltimore : The Williams and Wilkins Company.