

**PHONOLOGICAL ENCODING ABILITIES IN FIRST LANGUAGE OF
KANNADA-ENGLISH BILINGUAL ADULTS WHO STUTTER**

V.K.B. HIMA BINDH

Registration Number: 18SLP040

A Dissertation Submitted in Part Fulfilment of Final Year Master of Science (Speech-

Language Pathology)

University of Mysore

Mysore



ALL INDIA INSTITUTE OF SPEECH AND HEARING

MANASAGANGOTTHRI, MYSURU - 570006

JUNE 2020

CERTIFICATE

This is to certify that this dissertation entitled “**Phonological Encoding Abilities in First Language of Kannada-English Bilingual Adults who Stutter**” is a bonafide work submitted in part fulfilment for the degree of Master of Science (Speech-Language Pathology) of the student (Registration No: 18SLP040). This has been carried out under the guidance of a faculty of this institute and has not been submitted earlier to any other University for the award of any Diploma or Degree.

Mysore
June,2020

Prof. M. Pushpavathi
Director
All India Institute of Speech and Hearing
Manasagangothri, Mysore-570006

CERTIFICATE

This is to certify that this dissertation entitled “**Phonological Encoding Abilities in First Language of Kannada-English Bilingual Adults who Stutter**” is a bonafide work submitted in part fulfilment for the degree of Master of Science (Speech-Language Pathology) of the student (Registration No: 18SLP040). This has been carried out under my guidance and has not been submitted earlier to any other University for the award of any Diploma or Degree.

Mysore
June,2020

Dr. Sangeetha Mahesh
(Guide)
Clinical Reader & Head
Department of Clinical Services
All India Institute of Speech and Hearing
Manasagangothri, Mysore-570006

DECLARATION

This is to certify that this dissertation entitled “**Phonological Encoding Abilities in First Language of Kannada-English Bilingual Adults who Stutter**” is the result of my own study under the guidance of **Dr. Sangeetha Mahesh**, Clinical Reader and Head, Department of Clinical Services, All India Institute of Speech and Hearing, Mysore. This study has not been submitted earlier to any other University for the award of any Diploma or Degree.

Mysore
June, 2020

Registration No: 18SLP040

I DEDICATE THIS DISSERTATION TO

My MOM, V. PUSHPA KUMARI

My DAD, V.S.V. PRASADA RAO

My BROTHER, V. GANGADHAR

My BEST FRIEND, I.V.S. SASANK

My CAT, SKY

ACKNOWLEDGMENTS

I am deeply indebted to my guide **Dr. Sangeetha Mahesh** for her guidance and encouragement throughout my dissertation. I am grateful for her patience in making me properly oriented in my topic of research. Completing my dissertation would not have been possible without her support.

I am extremely grateful to my grandparents, athaya, mavayya & cousins who never failed to love me in every step of my life.

I would like to thank all my close friends Bhargavi, Sree Harika, Manvitha, Sindhu Bhairavi, Swetha, Hema Rinda Sai Madhuri, Monika, Fatema Mangalam, Narasimha Charya, Jagan Mohan, Farooq, Shyam who love me unconditionally and keep me sane.

Special thanks to fellow ACCHALAns, Pauline Gracia, Archana, Anuroopa, Aameena, Sashi Rekha, Vishnu and Vikram Sir.

I am most thankful to my senior Mr. Darshan, who always clarified my silly doubts and helped me throughout my dissertation.

Many thanks to all the participants in my study and Dr. C. Shijith Kumar, who took time to solve technical issues.

Last but not least, I would like to thank all my classmates BRANIACS.

TABLE OF CONTENTS

Chapter No.	Contents	Page No.
	List of Tables	
	List of Figures	
1.	Introduction	1 - 8
2.	Review of Literature	9 - 17
3.	Method	18 - 25
4.	Results	26 - 38
5.	Discussion	39 - 47
6.	Summary and Conclusions	48 - 53
	References	54
	Appendix	62

List of Tables

Table No.	Title of the Table	Page No.
3.1	Data depicting the demographics of participants in the clinical group.	19
4.1	Reaction time measures of ATM task in BAWS and BAWNS	28
4.2	Accuracy measures of ATM task in BAWS and BAWNS	28
4.3	Reaction time measures of PM task in BAWS and BAWNS	30
4.4	Accuracy measures of PM task in BAWS and BAWNS	31
4.5	Values of percentage of YES responses in PM and ATM task between BAWS and BAWNS	32
4.6	Values of percentage of NO responses in PM and ATM task between BAWS and BAWNS	33
4.7	Comparing the values of reaction times measures for YES-Initial and YES-Medial response of both the tasks in between BAWS and BAWNS	35
4.8	Values of the reaction time and accuracy measures of PM and ATM tasks in BAWS and BAWNS	36

List of Figures

Figure No.	Title of the Figure	Page No.
1.1	Blueprint of the speaker (Adapted from Levelt, 1989)	3
1.2	Phonological encoding (Based on Levelt et al., 1999)	3
1.3	Self-monitoring. (Adapted from Hartsuiker and Kolk, 2001)	4
1.4	Frame-based model of word-form encoding (From Dell, 1988)	5
1.5	Flow of information in the WEAVER++ model	6
3.1	Pictorial representation of the phoneme monitoring task	21
3.2	Pictorial representation of auditory tone monitoring task	22
4.1	Mean reaction time (ms) and accuracy measures (%) values for ATM task in BAWS and BAWNS	29
4.2	Mean reaction time (ms) and accuracy measures (%) values for PM task between BAWS and BAWNS	31
4.3		33

	Mean percentage of YES and NO responses	35
4.4	among both groups for PM and ATM tasks	
	Reaction time and accuracy measures of PM	
	and ATM tasks in BAWS and BAWNS	

Chapter I

INTRODUCTION

Stuttering is a disorder of fluency characterised by repetition and prolongation of sounds and syllables along with hesitations, pauses and blocks interrupting the constant flow of speech. Undesirable movements in face and extremities can accompany the disruption in the flow of speech. A person who stutters can develop unpleasant psychological concerns which can aggregate the disfluencies. Avoiding talking, fearing speaking situations, changing difficult words, and having low self-esteem are the major psychological concerns seen in persons with stuttering. Based on this, Stuttering was put under “Mental and behavioural disorders” section by the World Health Organization. It is estimated that more than 11 million people in India are affected by stuttering.

Stuttering is believed to have more than one cause rather than having a definite source. It can be familial, behavioural, or due to difference in cerebral performance. Van Riper (1982) stated that the cause of stuttering is heterogeneous. Most of the researches were done on motoric aspects on stuttering, and recent studies have focussed on the role of both motoric and linguistic aspects of stuttering. In linguistic aspects, mainly lexical access, phonological encoding was given the most attention. Deficits in phonological encoding were meant to be a plausible cause for the disfluencies in stuttering.

Many theories were proposed to show the link between phonological encoding and stuttering. Levelt (1989) explained language production under three sections, namely the conceptualise, formulator, and articulator. Levelt (1989) model is shown in figure 1.1. The conceptualised has information about the speaker’s intentions,

knowledge, and thoughts. A pre-verbal message which contains a semantic structure is generated in this phase. This message is sent to formulator where syntactic and phonological encoding is focussed. In grammatical encoding words for the message are chosen from the mental lexicon. In phonological encoding determines the phonological and metrical form of the words. The formulation of the speech follows this into articulatory gestures by the movement of the articulators. This phase of motor programming and execution takes place in the articulator. Once the desired message is generated and articulated overtly, the speech is analysed for its correctness through auditory processing and speech comprehension stages. A buffer is the temporary storage of the message's articulatory plan before the message has been articulated. The resultant message is called parsed speech which is monitored and sent back to conceptualiser. The speech is sent to the conceptualiser through two channels. The channel through auditory processing, after the message has been articulated is overt speech. The channel through which unarticulated message is sent from the buffer is called inner speech.

Phonological encoding begins from the word-form stage. The lexical concepts and lemmas are the stages from which the information is passed on to phonological encoding. Phonological encoding is depicted in figure 1.2. In phonological encoding processes, both the phonological segments and structures of the word. Few authors suggest that the information flow is unidirectional, i.e., from top to bottom (Levelt et al., 1999). Others assume that there might be a direct word form – segment and word form – lemma feedback (Damian & Martin, 1999; Dell, 1986; Vigliocco & Hartsuiker, 2002).

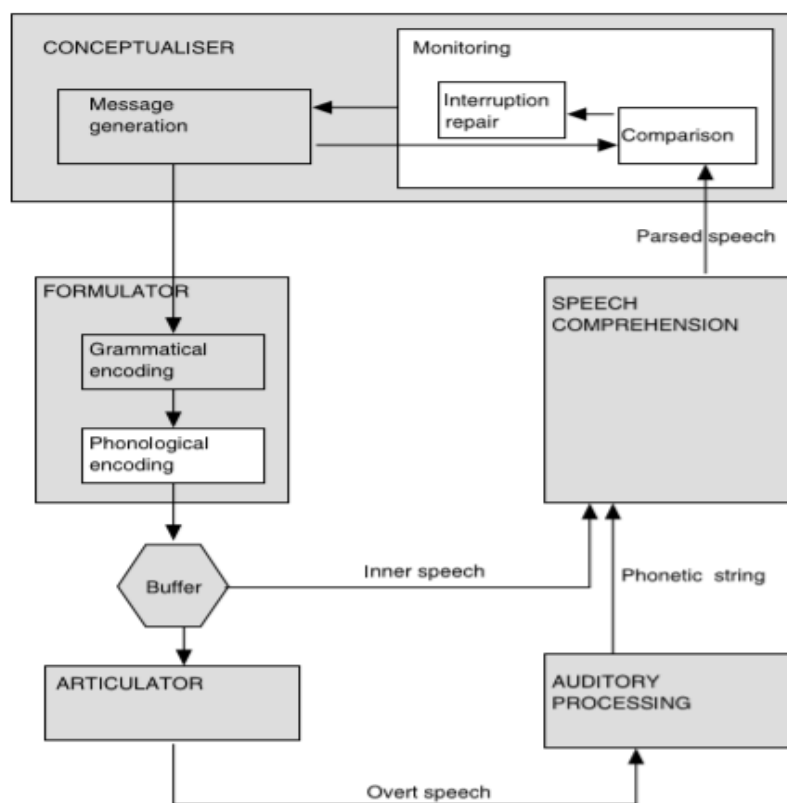
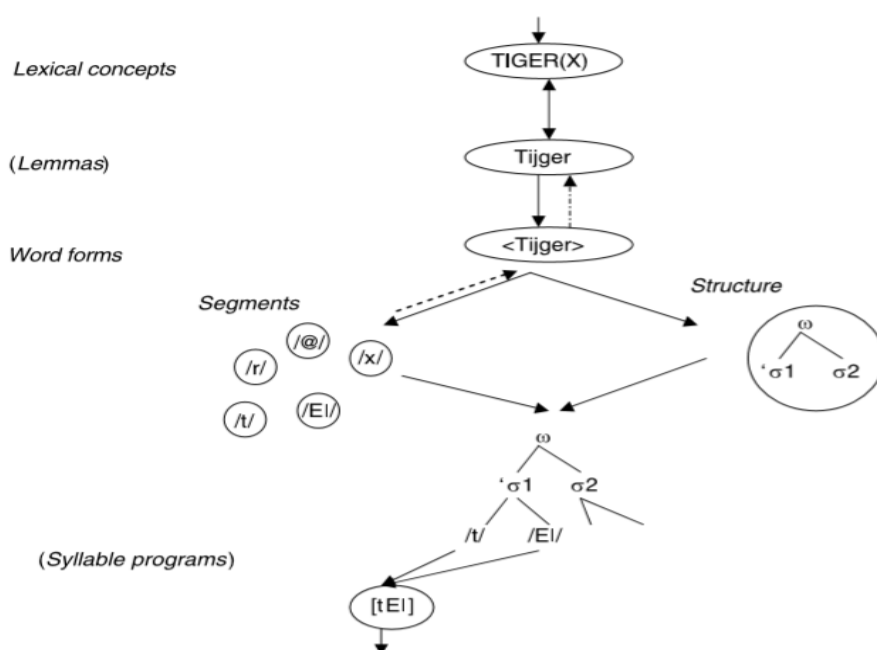
Figure 1.1*Blueprint of the speaker (Adapted from Levelt, 1989)***Figure 1.2***Phonological encoding (Based on Levelt et al., 1999)*

When speaker speaks out loud, they scrutinise what they hear, in the same way, there is a process in which the speaker can hear with saying it out loud such speech is called inner speech (Hartsuiker & Kolk, 2001). Figure 1.3 outlines the stages in self-monitoring, based on Levelt's (1983; 1989) perceptual loop theory and an amendment proposed by Hartsuiker and Kolk (2001). Initially, Levelt (1989) assumed the internal code is phonetic, and his later work claimed that it is a phonological code.

Figure 1.3

Self-monitoring (Adapted from Hartsuiker & Kolk, 2001)

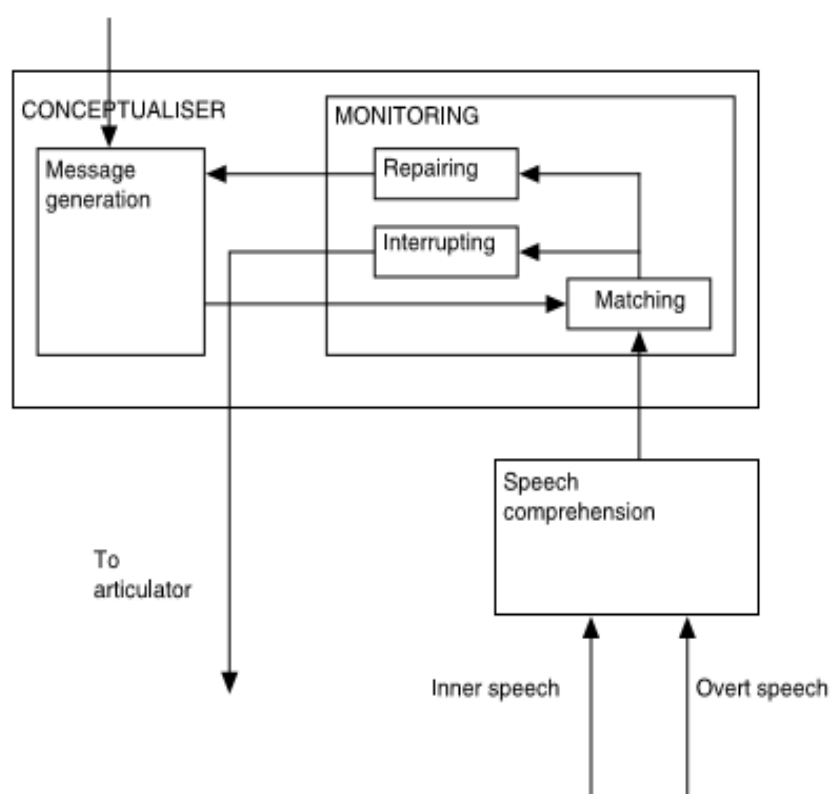

Speaking is a complex task in which planning the utterance precedes the production. Retrieving words from the lexicon, arranging them according to the grammatic rules and assigning the phonetic aspects are all the significant steps in speech production. Frame-based models show that phonemes which are the content units are inserted into the structural frames and are accessed independently during production

(Dell, 1986; 1988; Hartsuiker, 2002; Shattuck-Hufnagel, 1979; Stemberger, 1990). The structural frames are responsible for following the phonological rules of a language. Spreading activation model of Dell (1988) is one of the approaches under Frame-based model. Frame-based model is shown in figure 1.4. It consists of a lexical network and a structural network. The lexical network consists of words, and a structural network consists of word shape units and phoneme category units. At the beginning of the word form, the selected word in the lexical network activates the phoneme and word shape units. In this way, the selected phonemes and word shapes stay more active in the lexicon. Hence, the lexicon relates to both the phonemes and the structure. A phoneme is selected for output when it receives sufficient activation from both the current word unit and the current phoneme category unit.

Figure 1.4

Frame-based model of word-form encoding (From Dell, 1988)

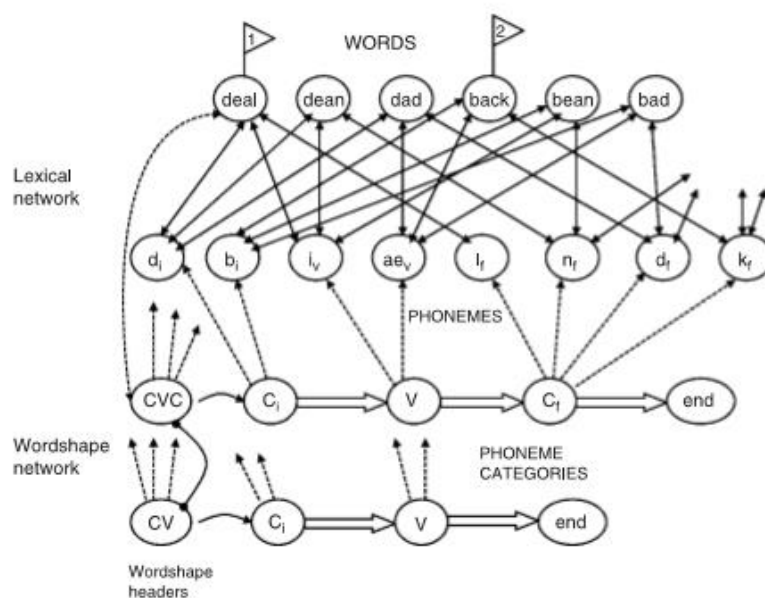

EXPLAN theory by Howell (2004) stated that the disfluencies in the speech are due to temporal asynchronies between the execution and speech planning. Complex

linguistic unit planning, fast speech rate and coping strategies are the reasons for the asynchronies. Covert Repair Hypothesis shows that the correction of errors in the speech plan caused by the phonological encoding of the speech sounds like a cause for the stuttering (Postma & Kolk, 1993). Fault Line Hypothesis by Wingate (1988) stated that stuttering is a result of the deficits in the lexical retrieval and encoding because of the fault-line caused at the location of the integration of syllable onset and rhyme. WEAVER++ model explains the interaction between the planning, comprehending, and monitoring phases in speech production and is explained in figure 1.5. (Levelt, Roelofs & Meyer, 1999). WEAVER++ model proposes that the word planning is a stepwise process that transverse the concept through lexical retrieval to word form encoding. WEAVER++ model is like Levelt model in assuming two routes, i.e., an internal and an external one. The external route monitors the speech after production, whereas the internal route monitors the speech before production. Word form encoding is further divided into morphological, phonological, and phonetic encoding.

Figure 1.5

The flow of information in the WEAVER++ model

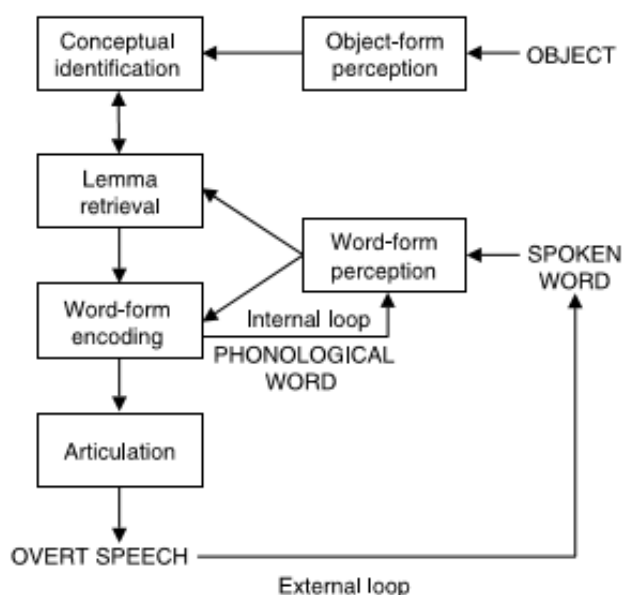

Purpose of the present study

Psycholinguistic theories emphasise that phonological encoding plays a vital role in the fluent production of speech. Literature also supports that the phonological encoding abilities vary among persons who stutter and who do not stutter. Along with specific phoneme monitoring, general monitoring deficits are seen in both adults and children who stutter. So, in the present study phoneme, monitoring paradigm and auditory tone monitoring tasks were selected to test the monitoring abilities in persons who stutter. Very few studies were done using phoneme monitoring paradigm on Indian bilingual persons who stutter.

The English-Mandarin bilinguals who stutter have a high percentage of dysfluent phonemes in less dominant language compared to the more dominant language (Valerie, 2008). As the number of bilingual speakers in India is increasing day by day, there is a need to study the phonological encoding abilities in bilingual adults who stutter. In the present study, phonological encoding abilities in L1 of Kannada-English bilingual adults were targeted. Studies prove that the phonological encoding abilities vary with the position of the phoneme in the word. Most of these studies were done on bisyllabic English words and trisyllabic Kannada words. No studies were done on bisyllabic Kannada words to know the position effect.

For this reason, the present study focuses on phoneme monitoring in bisyllabic words of the dominant language in Kannada-English bilingual adults who stutter. So, the present study aims to investigate the Phonological encoding abilities in L1 of Bilingual adults who stutter using phoneme monitoring paradigm and the objectives of the study are as follows:

1. To analyse and compare the reaction time and accuracy in phoneme monitoring task among bilingual adults who stutter (BAWS) and who do not stutter (BAWNS)
2. To analyse and compare the reaction time and accuracy in auditory tone monitoring task among bilingual adults who stutter (BAWS) and who do not stutter (BAWNS)
3. To check the influence of the position of target phoneme on monitoring abilities in phoneme monitoring task in both groups
4. To check the influence of the position of target pure tone on monitoring abilities in auditory tone monitoring task in both groups
5. To compare the phoneme monitoring task and auditory tone monitoring task within both groups.

Chapter II

REVIEW OF LITERATURE

A dive into the literature gave us information about the studies done of persons who stutter to know the mechanism in the pre-articulatory phase of speech production. Various experimental paradigms were developed to examine the errors during and before the speech production. These include analysis of spontaneous speech production, measuring the speech and accuracy in picture naming tasks. Though these give information about the errors after the production of the speech, the errors that occur before the speech production, i.e., during the planning stages are still unclear. To overcome this paradigm without the involvement of overt speech was needed. Silent phoneme monitoring tasks isolated the phonological encoding from overt speech production as the person is made to respond via pressing buttons rather than using his speech. Most of the studies using this paradigm are done on monolingual adults who stutter. There is limited literature on bilingual adults who stutter.

Phonological encoding in neuro-typical fluent speakers

Phonological encoding ability can be defined as “the processes involved in retrieving or building a phonetic or articulatory plan from each lemma or word and the utterance as a whole” (Levelt, 1989). The phonological encoding consists of three stages (a) forming of segments that form words, (b) combining sound segments with word frames, and (c) allocation of appropriate syllable stress (Levelt, 1989). Phonological encoding is considered the link between processes of lexical retrieval and speech production (Levelt, 1989; Levelt, Roelofs, & Meyer, 1999). It involves all the stages from mental concept preparation to the pre-articulatory stage. A lemma or mental concept is activated, the speaker then chooses the word followed by morpho-syntactic

encoding, phonological encoding, and finally phonetic encoding. The phonological encoding which occurs before the phonetic encoding must be with minimal errors to speak fluently without any disruptions (Hartsuiker, 2002; Indefrey & Levelt, 2004). Levelt et al. (1999) stated that phonological encoding occurs through external monitoring and internal monitoring. In external monitoring, the speaker monitors the speech via auditory feedback after he speaks to check the integrity of the message and in internal monitoring integration of the message is verified before the initiation of speech or pre-articulatory phase. This pre-articulatory monitoring during the encoding process allows the speaker to detect output errors in the speech plan before they are produced. Measuring the silently monitor ability gives an estimation of the speed and accuracy of phonological encoding in neuro-typical fluent speakers.

The study by Wheeldon and Levelt (1995) was the first study on phonological encoding. This study was done on bilingual Dutch-English participants. Bisyllabic stimuli with either initial or final stress were used. In the task, the participants monitored target phoneme in an aurally presented word by translating it from English to Dutch through silent naming. The second syllable has higher latency time compared to the first syllable irrespective of stress. Another study was done by Wheeldon and Morgan (2002) on phonological encoding in forty English-speaking adults. The stimuli consisted of bisyllabic words with CVCCVC patterns. Before the experiment, the participant ability to produce the words without articulatory error was tested. They have measured the reaction time for all the four consonants in CVCCVC words. The studied showed that the phonological transition sequentially happens from left-to-right. Also, it was found that vowel requires a longer planning time than a consonant.

Phonological encoding in adults who stutter

The study by Sasisekaran, Luc, Smyth, and Johnson (2006) measured phonological encoding ability in the silent speech of 10 AWS and 11 AWNS. Following a familiarisation task, participants completed an overt naming task, a monitoring task for the detection of target phonemes while silently naming pictures, and a simple motor task in response to pure-tone aural stimuli. Results indicated that AWS exhibited longer latencies significantly in phoneme monitoring compared to AWNS. However, there were no significant between-groups differences for response speed, picture naming accuracy, or simple motor tasks. Further, these reaction time data were dissimilar and longer than speakers' monitoring of auditory pure-tone sequences. These results suggest deficits at the level of phonological encoding in AWS, and not deficits in baseline reaction time, or auditory or perceptual monitoring abilities.

Another study by Sasisekaran and Luc (2006) has carried out a study on phonological encoding abilities in ten persons who stutter and ten persons who do not stutter. The task given was phoneme monitoring during silent picture naming and auditory perception tasks; the stimuli used are noun phrases and compound words. Analysis done by comparing the reaction time among the groups, indicated that person who stutter significantly have low reaction time than the person who do not stutter in phoneme monitoring of silent naming. However, the reaction time of phoneme monitoring in auditory perception task had no significant difference. The outcome shows that person who stutters has phoneme monitoring deficits rather than perception deficits.

A Chinese study on phonological encoding was conducted on 12 persons who stutter and compared it with a person who do not stutter (Zhang & Xiao, 2008). The

tasks included are simple motor task, over picture naming task and tone monitoring task. During silent naming, the participants were supposed to monitor target phonemes including Shengmu (initial consonants of Chinese syllables), Yunmu (simple or compound vowels of Chinese syllables), and Tones in Chinese phonetics. The results show response time of PWS was same as that of the PNS in Shengmu monitoring but was significantly slower in Yunmu and Tone monitoring than that of the PNS. No significant between-group differences among all the tasks. These findings suggest there is a specific deficiency at the level of phonological monitoring rather than general monitoring. The deficit was probably caused by the delayed phonological encoding of the PWS.

A study by Vincent, Grela and Gilbert (2012) measured the speech onset latency and stuttering frequency in fifteen adults who stutter and fifteen adults without stuttering. In phonological priming tasks, Cue words were used as stimuli which were presented in three conditions C-prime homogeneous, CV-prime homogeneous, and heterogeneous (C-prime heterogeneous and CV-prime heterogeneous). Verbal responses after each cue word were considered. Results revealed that adults without stuttering had lesser speech onset latency compared to adults who stutter in all priming conditions, and there was no significant change in stuttering frequency among conditions. This study suggests that phonological encoding may play no role, or only a minor role, in stuttering.

In the Indian context, Darshini and Swapna (2015) studied phoneme monitoring in the silent picture naming and auditory perception task of PWS. All the participants were monolingual native Kannada speakers. The stimuli consisted of 27 Kannada trisyllabic (CVCVCV) words with target phonemes /p/, /s/, /t/, /m/, /k/, /r/, /b/ and /h/ occurring in either initial, medial or final locations. The results revealed that the

difference in the reaction time between PWS and PNS was significant in both the task. However, for accuracy, there was a significant difference only in the silent naming task. It was found that phonemes in initial positions had poorer reaction time and best accuracy as compared to medial and final positions.

Metrical aspects of phonological encoding (i.e., stress and syllable boundary assignment) in adults who stutter was studied by Coalson and Byrd (2015). Silent monitoring task was performed on non-words by a total of 22 participants, of which 11 were adults with stutter and 11 were adults without stuttering. Experiment 1, the participants were supposed to monitor the target phoneme in initial stress stimuli and non-initial stress stimuli in experiment 2. They found that monitoring phoneme followed by non-initial stress. There was no significant difference in speech and accuracy to monitor stimuli with initial stress. Higher error rate to monitor non-initial stress syllable is seen in adults who stutter than adults who do not stutter. This study suggests that the metrical properties affect the reaction time in phonological encoding and may cause disruption in speech production, leading to disfluencies.

Phonological encoding of medial vowels in adults who stutter was studied by Allison Elizabeth (2016) through the silent phoneme monitoring paradigm. Total of 16 participants in two tasks eight in each. The stimuli used are bisyllabic non-word with CVCCVC structure. In experiment 1, eight participants were subjected to stimuli with initial stress and the remaining eight were subjected to stimuli with no initial stress. Results suggested that there was no significant difference in the speed and accuracy with and without the initial stress. Thus, it concluded that encoding of segmental and metrical information imposes higher demand during speech planning for individuals who stutter.

A study was conducted by Coalson and Byrd (2018) to know the role of subvocal rehearsal in phonological speech planning. A total of 20 adults (10 AWNS, 10 AWS) were participants in this study. Using silent phoneme monitoring tasks, phonological encoding in adults who stutter (AWS) compared to adults who do not stutter (AWNS). In this experiment, the participants had to identify the target phoneme present in trochaic non-word before and after the initiation of the subvocal rehearsal. To check, the difference in working memory for high phonological demand, the participants were given with identical low-frequency non-words with iambic stress. Results concluded that AWS had relative difficulties in monitoring compared to AWNS mainly when the target words are more phonologically demanding. The speed of responses was higher for initial phoneme of the stimuli irrespective of stress with 4 s delay.

Study on lexical access in adults who stutter was done by Howell and Ratner (2018). These authors have investigated the latency of lexical access of nouns and verbs in adults who stutters and compared it with adults who do not stutter using phoneme monitoring paradigm. The results showed that verbs are slower to monitor than nouns in both groups, initial phonemes have faster and more accurate when compared to medial and final phonemes and adults who stutter had more difficulty in medial phonemes. Non-significantly adults who do not stutter performed well than adults who stutter. Based on the above conclusion, this study proves that there is a phonological encoding difference between the two groups.

The study conducted by Pelczarski, Tendera and Loucks (2019) has studied phonological encoding using eye-tracking. In eighteen adults who stutter and eighteen adults who do not stutter using eye-tracking. Eye-tracking is a well-grounded method to assess phonological encoding while eliminating the impact of motor speech

production. Dwell time, several fixations and response time was recorded when eighteen adults who stutter read non-words under silent and overt conditions. The fifteen non-word stimuli in each condition included three one-syllable, four two-syllable, four three-syllable and four four-syllable. Results showed that response time was longer as the syllable length increased across conditions and in both groups. There is a significantly higher reaction time for adults who stutter in overt condition. In adults who stutter, dwell time and fixations are significantly longer in overt condition compared to silent reading. This study proves that adults who stutter need further processing time that could affect phonological or phonological-to-motor encoding.

Studies on Stuttering in Bilinguals

Study by Sindhu Priya and Santhosh (2016) investigated lexical access in Kannada-English bilingual adults who stutter and compared it with bilingual adults who do not stutter using semantic and cross-linguistic priming paradigm. In experiment 1, lexical access was assessed in each language separately, i.e., prime word and response word were in the same language across neutral prime, related prime and unrelated prime conditions. In experiment 2, lexical access was assessed using cross-linguistic prime, including two language condition, i.e., Kannada to English and English to Kannada. The priming conditions in experiment two were translation equivalent, related prime and unrelated prime condition. Results revealed that bilingual adults stuttering differently in both languages, and the frequency of stuttering was high in L2. Also, there is no difference in the lexical access in Kannada-English bilingual adults who stutter and who do not stutter stuttering, suggesting that the difficulty might be at the level of phonological encoding.

Research by Kashyap and Maruthy (2020) was conducted on Kannada-English balanced bilingual adults to measure and compare the stuttering frequency and severity between two languages. Speech samples of reading, speaking with SLP and conversing with family were collected across two situations, i.e., within-clinic and beyond-clinic. Total 18 bilingual adults who stutter participated in this study and their proficiency was tested with Language Experience and Proficiency Questionnaire (LEAP-Q) (Indian Version Ramya, 2009) and Online Proficiency Test (Prema, 2010). Analysis of syllables stuttered (%SS), and perceptual severity rating scores (SEV) revealed the difference in stuttering in two languages which can be due to the difference in the structure of these languages. %SS is higher in English compared to Kannada. Also, SEV scores were higher in English compared to Kannada, and a positive correlation was found across %SS and SEV.

Phonological encoding in bilingual individuals who stutter

A study by Sangeetha (2018) on phonological encoding skills was performed on thirty bilingual adults, among which fifteen are bilingual (Kannada-English) adults who stutter, and rest are bilingual adults who do not stutter. The experiment included four tasks, i.e., simple motor task, picture familiarisation and naming task, phoneme monitoring task and auditory tone monitoring task. Phoneme monitoring task had seventeen phonemes based on which fifty-one Kannada tri-syllabic and forty-seven English tri-syllabic nouns were made. Results revealed that in the simple motor task, bilingual adults who stutter (BAWS) had more reaction time and less accuracy compared to bilingual adults who do not stutter (BAWNS). However, the statistical significance is not seen. In phoneme and auditory tone monitoring task, similar results differences were seen but with a statistical difference. This study showed that the phonological abilities of L2 and L1 did not exhibit a significant difference. To

summarise, BAWS showed overall poor performance in simple motor, auditory tone and phoneme monitoring tasks compared with BAWNS concluding that BAWS has general monitoring deficits along with phonological encoding difficulties.

To summarise, studies done on persons who stutter to test their phonological encoding skills using either phoneme monitoring paradigm or eye tracking procedure show that there is a deficiency in phonological encoding processes of a person who stutter compared to a person who do not stutter.

Chapter III

METHOD

The present study aimed to explore the phonological encoding abilities in bilingual adults who stutter in comparison with bilingual adults who do not stutter. The tasks administered were phoneme monitoring (PM) and auditory tone monitoring (ATM) task using DMDX software via computer. The speed and accuracy of responses during these tasks were measured and compared across groups.

Participants

Twenty participants of age range 18-35 years have contributed to the present study. It includes ten clinical subjects and ten control subjects. All the participants were bilinguals, the native language was Kannada, and the second language as English. They had a minimum social proficiency on the International Second Language Proficiency Rating Scale (ISLPR, Wylie, & Ingram, 2010). The participants in the clinical group had moderate to severe range of stuttering, evaluated by a speech-language pathologist on the Stuttering Severity Instrument (SSI Version 4, Riley, 2009). The participants of the control group were age, and gender matched bilingual adults who do not stutter. Participants reported no history of intellectual, sensory (vision and hearing), neurological or other communication disorders. The cognitive skills were screened with the Montreal Cognitive Assessment (MoCA).

Following ethical protocol, explained the purpose of the study and given a brief about the task procedures to the participants. Informed verbal/written consent was taken before the administration of tasks.

Table 3.1

Data depicting the demographics of participants in the clinical group

Participants	Age and Gender	Severity of Stuttering
P1	23yrs/Male	Moderate Stuttering
P2	28yrs/Female	Moderate Stuttering
P3	25yrs/Male	Moderate Stuttering
P4	22yrs/Male	Moderate Stuttering
P5	26yrs/Male	Moderate Stuttering
P6	26yrs/Male	Moderate Stuttering
P7	25yrs/Male	Severe Stuttering
P8	29yrs/Male	Severe Stuttering
P9	28yrs/Male	Severe Stuttering
P10	21yrs/Male	Severe Stuttering

Procedure

The PM and ATM tasks were performed in two phases

Phase I: Preparation of Stimulus and Designing the Task

Phase II: Task administration on participants

Phase I: Preparation of Stimulus and Designing the Task

Phoneme Monitoring Task

Stimuli: For the current study 10 highly disfluent phonemes /D/, /T/, /r/, /p/, /g/, /c/, /t/, /v/, /k/, /s/ of Kannada (Shishira, 2019) were selected. Sixteen picturable bisyllabic words (CVCV) with the target consonants present in either initial or medial

positions were selected. The pictures were judged and validated by three Speech-Language Pathologists based on three parameters, i.e., image agreement, word familiarity and image appropriateness. These parameters are rated on a 3-point rating scale.

- Image & Name Agreement – Picture to name comparability
 - 0 – No comparability
 - 1 – Partial comparability
 - 2 – Most comparability
- Word Familiarity – Familiar of the target noun in everyday usage
 - 0 – Unknown
 - 1 – Partially known
 - 2 – Most known
- Image Appropriateness – To see if the target noun selected is age appropriate
 - 0 – Inappropriate
 - 1 – Slightly appropriate
 - 2 – Most appropriate

The pictures & words scored less were replaced with more appropriate items. The audio samples of the target consonants combined with vowel /a/ were approved by three Speech-Language Pathologists. The target pictures in PM task were presented in two blocks after five trial items. In the first block, forty items are presented. Among them twenty pictures had target phoneme, thus needing a YES response and twenty pictures had no target phoneme thus needing a NO response. In the second block, five items were presented, which were randomly chosen from the first block to check the reliability of responses. The items were randomised before every presentation and are counterbalanced.

Instrumentation: The targeted consonants combined with vowel /a/ were pre-recorded in a sound-treated room by a native Kannada speaker at an appropriate intensity using PRAAT Software (Version 5.3). DMDX software (Version 6.1.2.15) was used to present the pre-recorded audio of targeted phoneme along with the familiarised picture and to record the responses of the participants. The Keys for ‘YES’ and ‘NO’ responses were assigned to left, and right keys on mouse/mousepad respectively and are colour coded, i.e., green for YES and red for NO.

Test Design: Before the presentation of target phoneme, a blank screen displayed for 500ms. Target phoneme was followed by the presentation of a picture for 3000ms. An inter-stimulus gap of 500ms was present. The participants were instructed to press YES or NO immediately after looking at the picture. Before the presentation of the next item, an interstimulus gap of 500ms is given.

Figure 3.1

Pictorial representation of the phoneme monitoring task

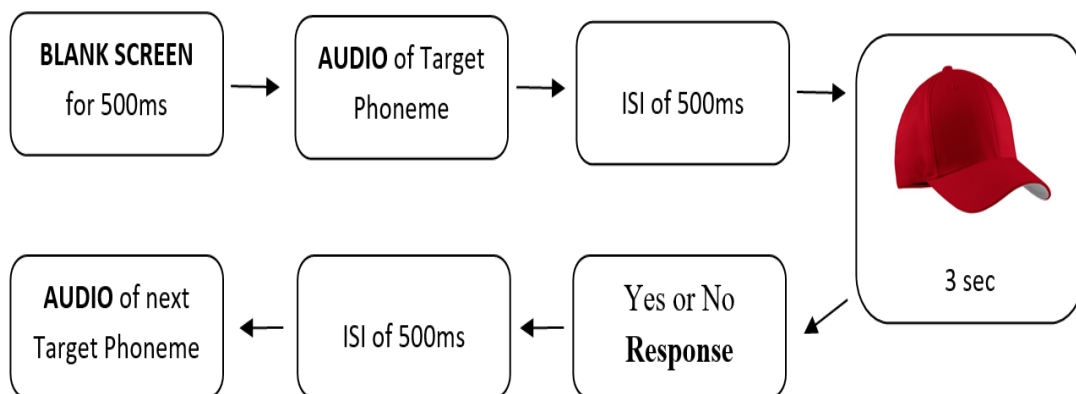

Auditory Tone Monitoring Task

Stimuli: The stimuli for ATM task were 1 kHz and 500 Hz pure tones. This test had a total of ten items, including three trial items. The target tone in this task was 1kHz, and the two-tone sequences consisted of 1kHz-500Hz, 500Hz-1kHz, 1kHz-1kHz

and 500Hz-500Hz combinations. A YES response was given if the target tone 1kHz was present in the two-tone sequence and NO response if it is absent. The items were randomised before every presentation and are counterbalanced.

Instrumentation: The duration of the sixteen words used for stimuli was noted using PRAAT Software (Version 5.3) and averaged. The duration of the pure tones was made equal to the mean length of sixteen words, i.e., 70ms. The 1kHz target tone and two-tone sequences with a gap of 50ms were generated using Adobe Audition 3 (Version 3.0.1). DMDX software (Version 6.1.2.15) was used to present the target tone and a two-tone sequence. Responses were recorded using the left and right keys on the mouse/mousepad for ‘YES’ and ‘NO’ responses respectively and are colour coded, i.e., green for YES and red for NO.

Test Design: The test started with the appearance of a blank screen for about 500ms, followed by the appearance of target 1 kHz pure tone. An inter-stimulus gap of 500ms was given, which is then followed by the appearance of the two-tone sequence. Immediately after the appearance of the two-tone sequence, the participants responded YES or NO. Before the presentation of the next item, an interstimulus gap of 500ms is given.

Figure 3.2

Pictorial representation of auditory tone monitoring task

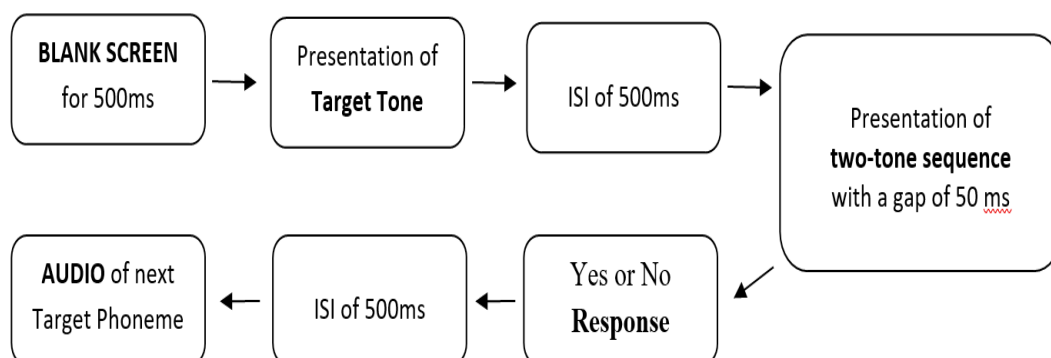

Pilot study

After programming the PM and ATM tasks, a pilot study was performed on two speech-language pathologists. They have judged the appropriateness of the task design, i.e., duration of test stimuli (pure tones) and interstimulus interval. It took nearly half-an-hour to forty-five minutes to complete the whole experiment. A break was given after half the test items and is not time-bound; the participants continued the test when they were ready.

Phase II: Task administration on participants

Phoneme Monitoring Task

Procedure: First, all the individuals who were participating were familiarised with the sixteen stimuli pictures and their names through the naming task. The individuals who were participating were asked to name the stimuli picture shown in Kannada and were corrected if they named it wrong. This task was done until the individuals who were participating were able to name all the pictures correctly without any help.

Further the PM task was carried on. The individuals who were participating were explained that they would hear a phoneme, and after that, a familiarised picture would appear on the screen. Individuals who were participating were instructed to press YES if the phoneme is present in the name of the picture through silent naming, monitor the target phonemes irrespective of their position and vowel, i.e., the phoneme can be present in initial or medial position and can be any vowel. Press NO if the phoneme is absent in the name of the picture. The individuals who were participating got instructions to respond as quickly & accurately possible.

Auditory Tone Monitoring Task

Procedure: Firstly, 1 kHz target pure tone was presented, followed by a two-tone sequence, i.e., either 1kHz-500Hz or 500Hz-1kHz or 1kHz-1kHz or 500Hz-500Hz. Participants were instructed to press YES if the target tone i.e., 1kHz tone is present in the either of the tones in two-tone sequence and press NO if it is absent. The participants were told to respond as quickly & accurately possible.

Analysis

The reaction time and accuracy of the responses for PM and ATM tasks were recorded in DMDX software (Version 6.1.2.15). The reaction time for PM task and ATM tasks are measured in milliseconds. The incorrect responses were assigned a negative (-) sign and are excluded from the analysis, whereas the correct responses (YES and NO responses) of both the tasks are obtained and averaged. The percentage of accurate responses is taken. To know the position effect in PM task and ATM tasks the average reaction time and accuracy percentage across the positions (initial, medial) is compared.

Reliability

To check the reliability of the present study, test re-administration was done on five participants who were selected randomly. To see the regularity of the responses by participants same test was re-administered after a week of initial testing.

In the clinical group, the reliability of reaction time and accuracy was checked in PM and ATM tasks. In PM task it was found that the test-retest reliability coefficient (r) was found to be greater than 0.9 for all the test items indicating excellent reliability of the PM testing procedure. In ATM task it was found that the test-retest reliability

coefficient (r) was found to be greater than 0.9 for all the test items indicating excellent reliability except for the initial responses which was 0.86 indicating good reliability.

Similarly, in the control group the reliability of reaction time and accuracy was checked in PM and ATM tasks. In PM task it was found that the test-retest reliability coefficient (r) was found to be greater than 0.9 for all the test items indicating excellent reliability except for the NO responses which was 0.86 indicating good reliability. In ATM task it was found that the test-retest reliability coefficient (r) was found to be greater than 0.9 for all the test items indicating excellent reliability.

Chapter IV

RESULTS

The current study aimed to check the phonological encoding skills in bilingual adults who stutter (BAWS) and compare to bilingual adults who do not stutter (BAWNS) using a phoneme monitoring paradigm in first language, Kannada. Silent naming was preferred during the phoneme monitoring to exclude the influence of overt speech from the experiment. For measuring the monitoring abilities, the reaction time of each individual and accuracy in which they had responded were measured in two tasks namely phoneme monitoring task (PM) and auditory tone monitoring task (ATM). A comparison among the tasks, among the groups and within the groups was made for both the reaction time and accuracy. The data obtained was analysed using SPSS software to see if there is any significant difference for both the tasks among both the groups.

- Descriptive statistics was done to calculate the mean, standard deviation and median of data obtained for PM and ATM tasks for both the groups.
- Shapiro-Wilk's test of normality was done to check whether the data is normally distributed in reaction time and accuracy measures.
- Mann-Whitney test was done to check if there is a significant difference in reaction times, accuracy, and position effect for both the tasks across both the groups.
- Wilcoxon Signed Ranks test was done to check if there is a significant difference in reaction times, accuracy, and position effect for both the tasks within the groups.

The results are explained under following subheadings:

- Comparison of the measures in Auditory Tone Monitoring task among BAWS and BAWNS.
- Comparison of the measures in Phoneme Monitoring task among BAWS and BAWNS.
- Influence of position of target on monitoring abilities in Phoneme Monitoring and Auditory Tone Monitoring tasks within and among both groups.
- Reaction time and accuracy of Phoneme Monitoring and Auditory Tone Monitoring tasks within both groups.

1. Comparison of the measures in Auditory Tone Monitoring task among BAWS and BAWNS.

The distribution of the acquired data is not normal in clinical and control groups for ATM task. Hence, a non-parametric test called Mann Whitney was used to compare the reaction time and accuracy data of clinical and control groups. In ATM task, the participants were supposed to monitor the presence or absence of target tone i.e., 1kHz from a series of two-tones. The time taken by the participants from the presentation of target tone to identifying the presence or absence of the target tone by pressing YES or NO buttons is considered as reaction time. In table 4.1, the reaction time values for ATM task are listed. On comparison, they reveal that BAWS had greater reaction time than BAWNS i.e., BAWS took more time to react precisely after the presentation of stimuli. There was a significant difference of reaction time between groups ($|z| = 2.42$, $p < 0.05$). When the participant correctly identified the presence or absence of the target tone in two-tone sequence it was considered as accurate response. In table 4.2, the accuracy values for ATM task are listed. On comparison, they reveal that BAWNS

responded more accurately in ATM task than BAWS and the difference was not significant ($|z| = 0.35$, $p > 0.05$) among groups. The accuracy and reaction time values of ATM task is represented in a graph in the figure 4.1.

Table 4.1

Reaction time measures of ATM task in BAWS and BAWNS

GROUPS	AUDITORY TONE MONITORING TASK				
	Reaction Time				
	Mean	SD	Median	z value	p value
BAWS	895.58	266.51	881.20		
BAWNS	621.54	190.22	603.74	2.42	.02*

* $p < .05$

Table 4.2

Accuracy measures of ATM task in BAWS and BAWNS

GROUPS	AUDITORY TONE MONITORING TASK				
	Accuracy %				
	Mean	SD	Median	z value	p value
BAWS	78.33	22.29	83.33		
BAWNS	83.33	13.61	83.33	.35	.72

Figure 4.1

Mean reaction time (ms) and accuracy measures (%) values for ATM task in BAWS and BAWNS

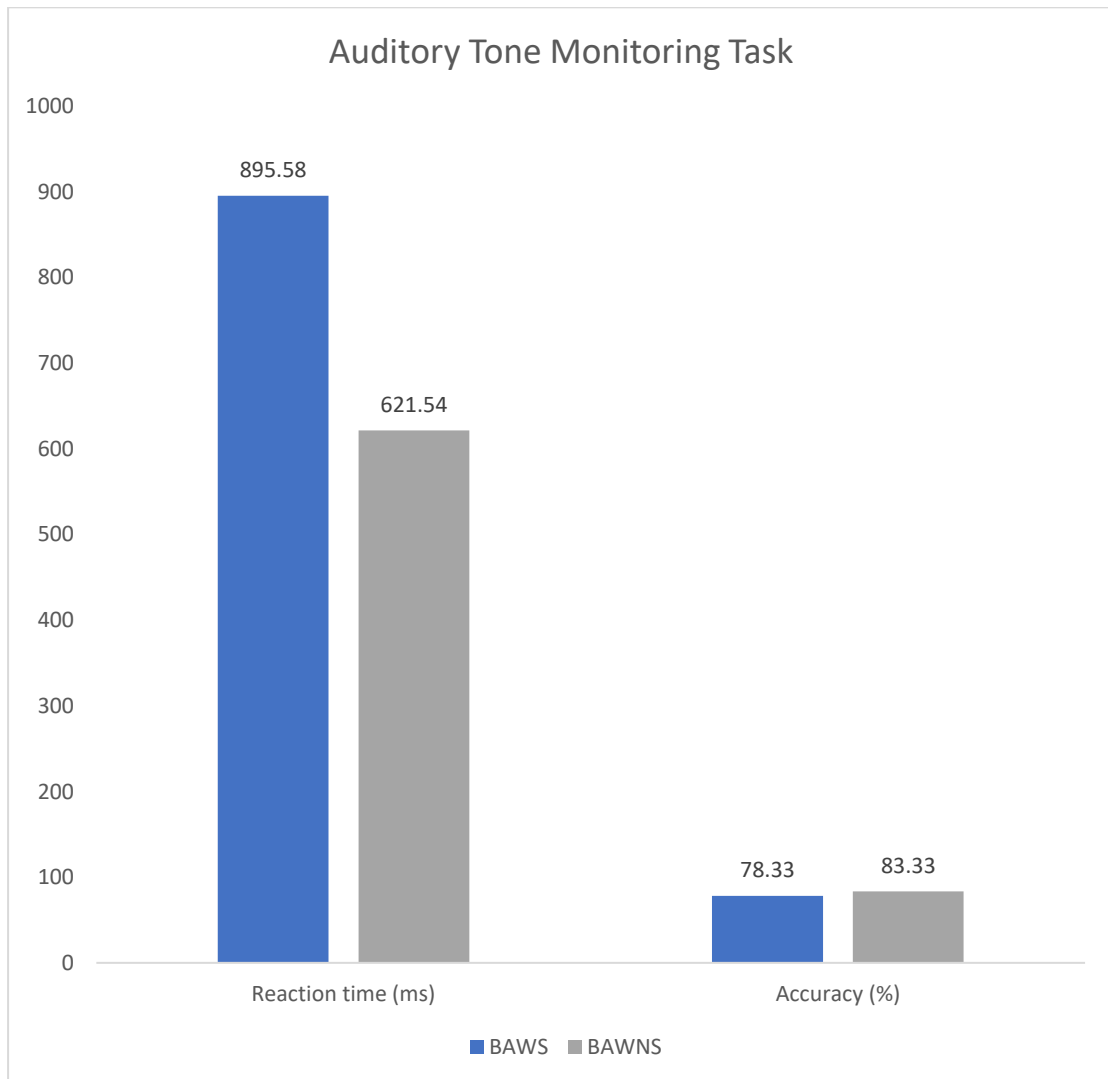

2. Comparison of the measures in Phoneme Monitoring task among BAWS and BAWNS.

The distribution of the acquired data is not normal in clinical and control groups for PM task. Hence, a non-parametric test called Mann Whitney was used to compare the reaction time and accuracy data of clinical and control groups. The results obtained for the PM task followed the same pattern as the ATM task values. In PM task, the

participants were supposed to monitor the presence or absence of a target consonant by looking at a picture and through silently naming it. The time taken from the stimuli presentation till the response of the participant by pressing either YES or NO is considered as the reaction time. In table 4.3, the values of the reaction time in PM task are listed. On comparison, they reveal that BAWNS had greater reaction time than BAWNS i.e., BAWNS took more time to react correctly after the presentation of stimuli and difference found was significant ($|z| = 3.78, p < 0.05$) across group. The accurate responses are those in which the participant has correctly identified the presence or absence of the target consonant in the name of the picture presented by pressing YES or NO buttons. In table 4.4, the accuracy values of PM task are listed. On comparison, they reveal that BAWNS responded more accurately than BAWNS and significant difference is not seen ($|z| = 1.03, p > 0.05$) among groups. The values of accuracy and reaction time measures in PM task are represented in a graph in the figure 4.2.

Table 4.3

Reaction time measures of PM task in BAWNS and BAWNS

GROUPS	PHONEME MONITORING TASK				
	Reaction Time				
	Mean	SD	Median	z value	p value
BAWNS	1525.70	162.99	1480.10		
BAWNS	1170.57	112.72	1146.65	3.78	.000***

*** $p < .001$

Table 4.4*Accuracy measures of PM task in BAWS and BAWNS*

GROUPS	PHONEME MONITORING TASK				
	Accuracy %				
	Mean	SD	Median	z value	p value
BAWS	75.25	15.70	76.25		
BAWNS	83.75	9.74	85.00	1.03	.31

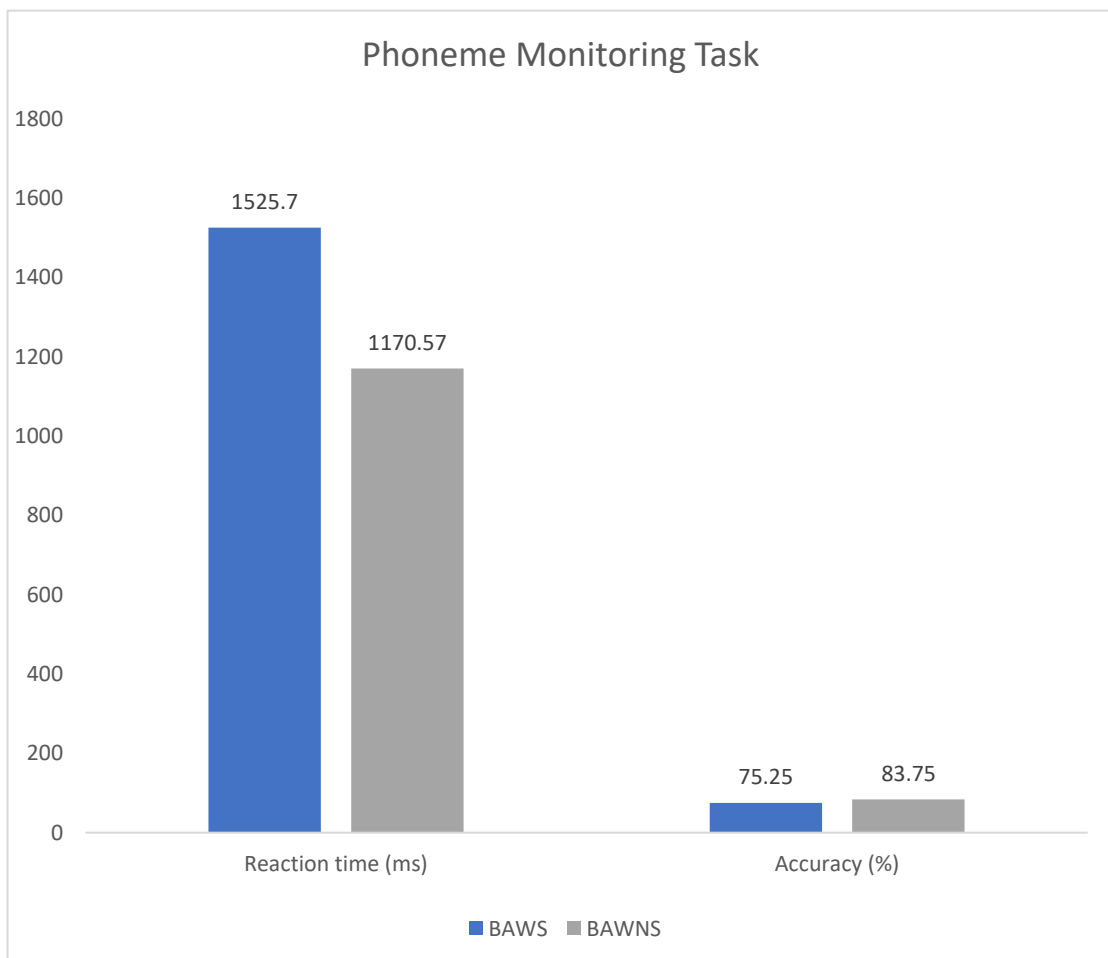
Figure 4.2*Mean reaction time (ms) and accuracy measures (%) values for PM task between BAWS and BAWNS*

In both the task the stimuli were distributed such that there are equal number of stimuli with YES and NO response. To know the distribution of accurate YES and NO responses within and among the group, the percentage of correct YES responses and NO responses in both PM and ATM task were obtained and averaged. In table 4.5, the values of YES responses are listed and in table 4.6, the values of NO responses are listed. Results show that among correct responses YES responses were more than NO responses. It was easy for the participants to identify the presence of the phoneme/tone rather than the absence of the phoneme/tone. Among groups BAWNS had highest number of correct NO responses than that of BAWNS. This difference was not statistically significant in both PM task ($|z| = 0.80$, $p > 0.05$) and ATM task ($|z| = 0.82$, $p > 0.05$). Though there was a difference in YES and NO responses, corresponding group effect is not found.

Table 4.5

Values of percentage of YES responses in PM and ATM task between BAWNS and BAWNS

GROUPS	% of YES Responses			
	PHONEME MONITORING TASK		AUDITORY TONE MONITORING TASK	
	Mean	SD	Mean	SD
BAWS	50.40	6.16	69.50	11.50
BAWNS	48.15	3.67	64.66	7.53

Table 4.6

Values of percentage of NO responses in PM and ATM task between BAWS and BAWNS values

GROUPS	% of NO Responses			
	PHONEME MONITORING TASK		AUDITORY TONE MONITORING TASK	
	Mean	SD	Mean	SD
BAWS	49.60	6.16	30.50	10.9
BAWNS	52.45	4.03	35.34	7.14

Figure 4.3

Mean percentage of YES and NO responses among both groups for PM and ATM tasks

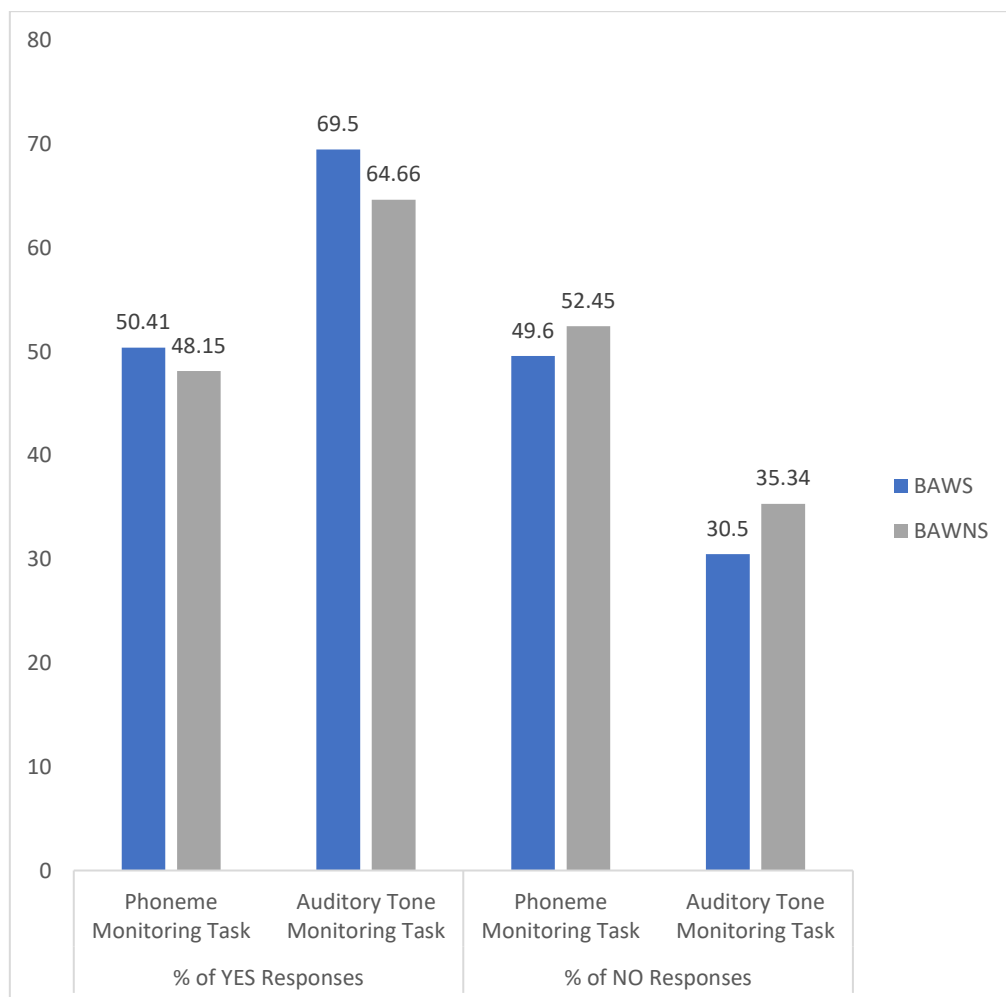

3. Influence of position of target on monitoring abilities in Phoneme Monitoring and Auditory Tone Monitoring tasks within and among both groups.

In the present study the monitoring abilities were tested across two positions i.e., initial, and medial. In PM task, sixteen bisyllabic words were used as stimuli and two-tone sequences were used as stimuli in ATM task. Mann Whitney was used to compare the reaction time and accuracy among the clinical and control group whereas Wilcoxon Signed Ranks tests were used to compare the mean reaction time of initial and medial responses within the clinical and control groups. In BAWS, among both the tasks the reaction time was faster when the target phoneme/tone is in the initial place ($|z| = 2.6, p < 0.05$) and slower when the target phoneme/tone is in medial place ($|z| = 2.8, p < 0.05$). Similar patterns were seen in BAWNS, the reaction time was faster when the target phoneme/tone is in the initial place ($|z| = 2.8, p < 0.05$) and slower when the target phoneme/tone is in medial place ($|z| = 2.1, p < 0.05$). Statistical difference is seen among tasks in both the places. So, in both the groups and in both the tasks the reaction time in the initial place is less than the reaction time in medial place. This shows that encoding follows a left to right sequence i.e., processing of initial syllable happens prior to the activation of the medial syllable in the encoding phase of speech production.

In table 4.7 the values of reaction time in initial and medial place in both the tasks are listed. No group effect is seen regarding the place. Among groups, statistical difference is seen among both the places in PM task; in ATM task significant difference is seen only in the initial place. In figure 4.3. mean percentage values of YES responses across initial and medial position in both the tasks between BAWS and BAWNS is graphically depicted.

Table 4.7

Comparing the values of reaction times measures for YES-Initial and YES-Medial response of both the tasks in between BAWS and BAWNS

Task	Position	BAWS	BAWNS	 z value	p value
PM	INITIAL	1372.12	1033.69	3.69	.000***
	MEDIAL	1612.11	1288.05	3.02	.002**
ATM	INITIAL	761.16	501.96	2.04	.04*
	MEDIAL	835.63	696.10	1.66	.09

***p < .05, **p < .01, ***p < .001**

Figure 4.3

Mean percentage values of YES responses across initial and medial place in both the tasks between BAWS and BAWNS

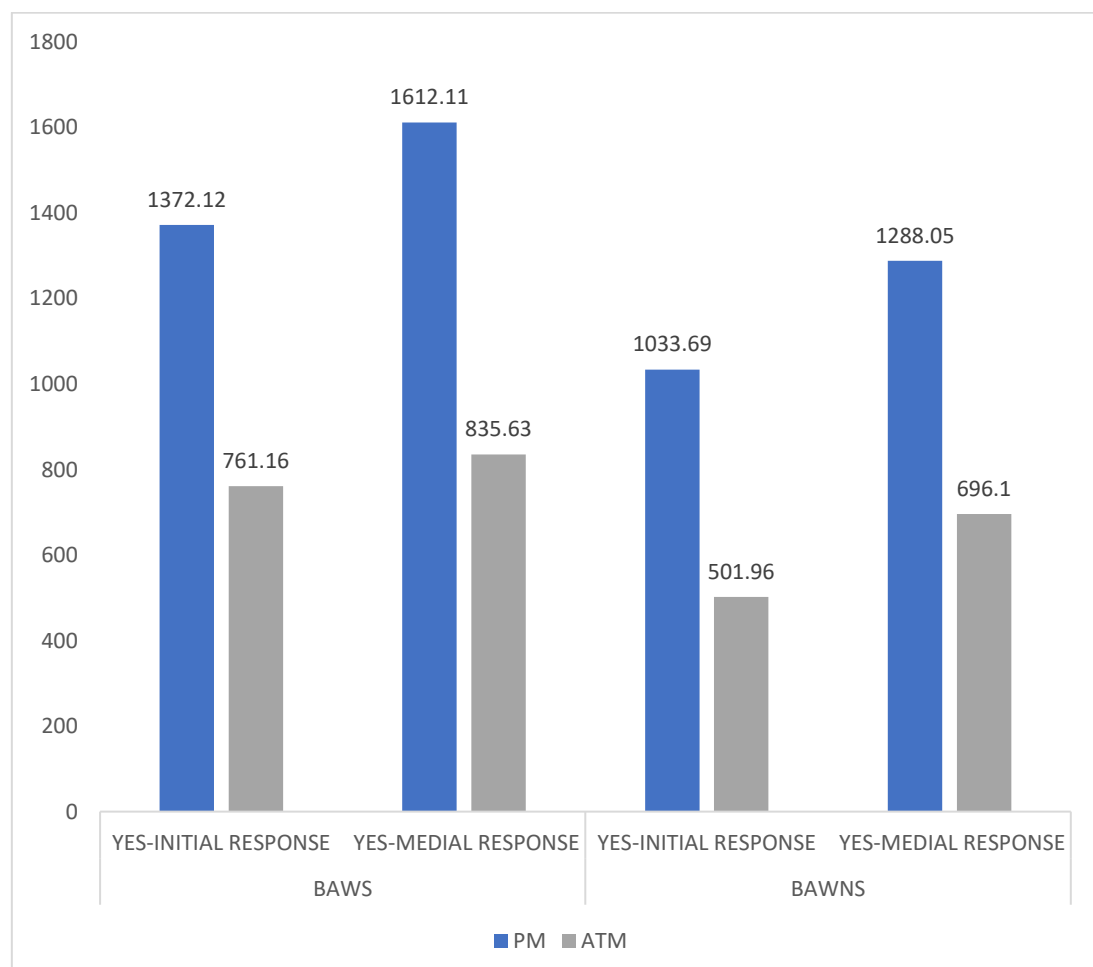

4. Reaction time and accuracy of Phoneme Monitoring and Auditory Tone

Monitoring tasks within both groups

To see the Comparison of reaction time and accuracy between the PM and ATM tasks Wilcoxon signed rank test was used. In both the groups, the reaction time of ATM task was better than PM task and are significantly different (BAWNS - $|z| = 2.70$, $p < 0.05$, BAWS - $|z| = 2.70$, $p < 0.05$). The accuracy of both the tasks were almost similar and the difference has no significant value (BAWNS - $|z| = 0.25$, $p > 0.05$, BAWS - $|z| = 2.70$, $p > 0.05$). The values of reaction time and accuracy measures of PM and ATM task in both BAWS and BAWNS was given in the table 4.8 and the same is depicted graphically in figure 4.4. The PM task consists of ten phonemes to monitor across sixteen bisyllabic words, whereas in ATM task 1kHz target tone has to be monitored across four patterns of two-tone sequences. Though the BAWNS had accurately responded to a greater number of stimulus items than BAWS, with in each group there was not much difference in identifying the target phoneme/tone across tasks.

Table 4.8

Values of the reaction time and accuracy measures of PM and ATM tasks in BAWS and BAWNS.

	PM				ATM			
	RT	$ z $ p	Acc. %	$ z $ p	RT	$ z $ p	Acc. %	$ z $ p
BAWS	1525.70	3.78	75.25	1.03	1170.57	2.50	83.75	.35
BAWNS	895.58	.000***	78.33	.31	621.54	.02*	83.33	.72

* $p < .05$, *** $p < .001$

Figure 4.4

Reaction time and accuracy measures of PM and ATM tasks in BAWS and BAWNS

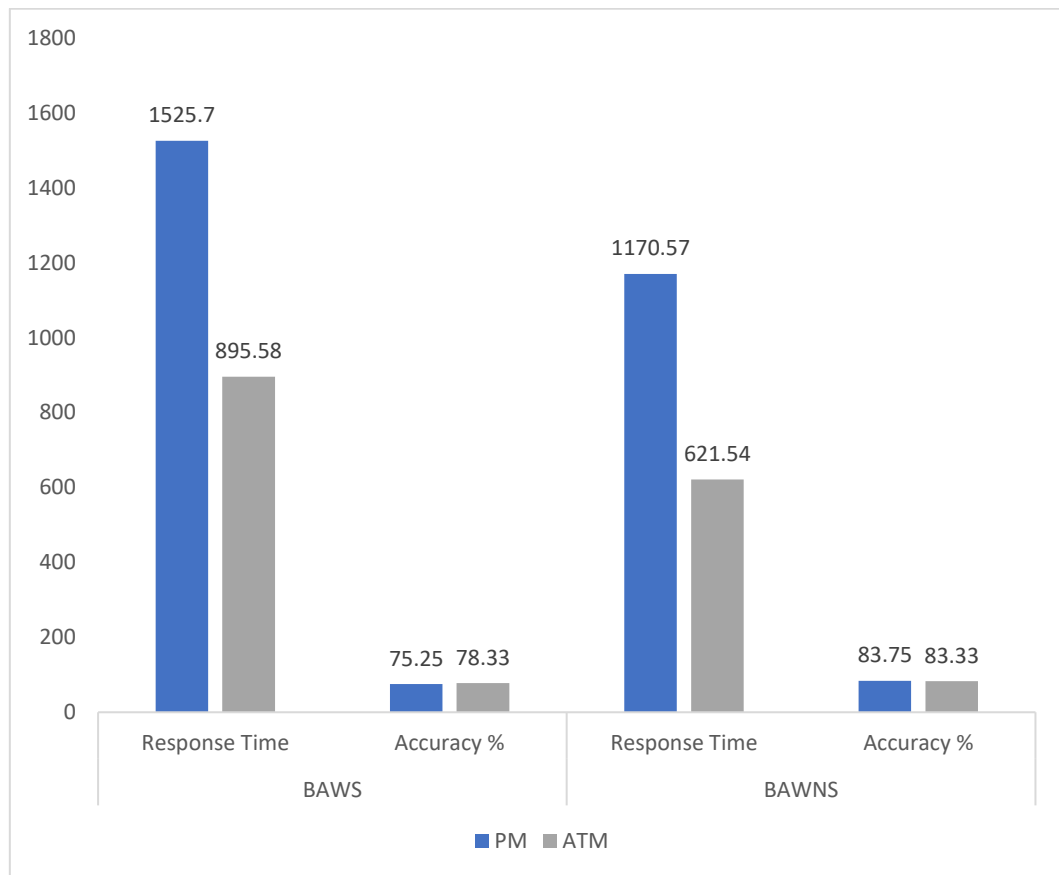

In summary, the above results show that BAWS took more time to identify the presence or absence of the target phoneme/tone when compared to BAWNS. Similarly, BAWNS had a greater number of correct responses than BAWS. Across tasks, the reaction time was less for ATM task and more for PM task. This was due to the complexity and variations in stimulus of PM task. There was a significant difference between the groups for reaction time. Such difference is not found for accuracy between tasks. Both the groups had performed similarly across tasks in terms of accuracy. With respect to place, the reaction time was less when the target phoneme/tone is in initial place than in medial place. This was similar across tasks and the difference was

significant except for medial place in ATM task. In both the tasks YES responses were greater than the NO responses.

Chapter V

DISCUSSION

The present study aimed to explore the phonological encoding abilities in bilingual adults who stutter (BAWS) in comparison with bilingual adults who do not stutter (BAWNS). The phonological encoding is the procedure by which the phonemes are arranged in the process of speech production prior to the articulation phase. The phonological encoding ability is said to be impaired in the individuals who stutter leading to the disfluencies in their speech. In the present study to check this phonological encoding ability phoneme monitoring paradigm was used along with auditory tone monitoring task to know about the general monitoring skills of the individual. The two main measures considered were reaction time and accuracy. The time taken to respond YES or NO after the presentation of the stimuli is called the reaction time and accuracy means the number of correct responses in each task. These measures of reaction time and accuracy gave details about the speed in which the information is being processed and how correctly the individual can find the presence or absence of target phoneme or tone in the name of the picture or two-tone sequence respectively. The speciality of phoneme monitoring paradigm with silent naming is that it gives us the details of phonological encoding without the interference of overt speech. For this study Kannada-English BAWS and BAWNS of age range 18-35 were considered. To analyse and compare the reaction time and accuracy in PM task among BAWS and BAWNS. Main objectives of the study were as follows

1. To analyse and compare the reaction time and accuracy in auditory tone monitoring task among bilingual adults who stutter and who do not stutter

2. To check the influence of position of target phoneme on monitoring abilities in phoneme monitoring task in both groups.
3. To check the influence of position of target pure tone on monitoring abilities in auditory tone monitoring task in both groups.
4. To compare phoneme monitoring task and auditory tone monitoring task within both groups.

Auditory Tone Monitoring Task- Reaction Time and Accuracy Measures

In ATM task, BAWS (895.58) took more time to react precisely than BAWNS (621.54) to identify the presence or absence of the target tone in the two-tone sequence. The difference in the reaction times between group was found to be significant ($|z| = 2.42, p < 0.05$). Regarding accuracy, BAWS (78.33) have a smaller number of correct responses than that of BAWNS (83.33). This accuracy percentage did not have significant difference ($|z| = 0.35, p > 0.05$). With regard to YES and NO responses across groups it was found that BAWNS (83.33) have greater percentage of YES responses than BAWS (78.33). But, for NO responses BAWS (21.67) had greater percentage than BAWNS (16.67).

Similar results were obtained in the study done by Sasisekaran et al. (2006) indicating that AWS reaction time data were dissimilar and longer than speakers' monitoring of auditory pure-tone sequences. However, there were no significant between-groups differences for response speed of ATM. Results of Zhang and Xiao (2008) are similar to the present study for tone monitoring, PWNS had better response time than PWS with no significant difference. As the study was done in Chinese language, this shows that the PWS have general monitoring deficits irrespective of the language. In Indian context similar results were seen in study performed by Sangeetha, Amulya, Sabeena and Geetha (2019) which revealed that in ATM task, BAWS had

more reaction time compared to BAWNS with statistical difference and concluded that BAWNS have general monitoring deficits along with phonological encoding difficulties. Therefore, the results obtained in the present study are supported by literature and shows that BAWNS have difficulty in general monitoring when compared to BAWNS. The ATM task has better responses in terms of reaction time than PM task. The possible reasons for this might be simplicity of the task.

The accuracy of responses in BAWNS were lesser than BAWNS. Study by Goncalves, Andrade and Matas (2015) states that in CWS timing deficits were seen in the brain stem functioning because of which there might be poor processing of acoustic information. The auditory cortices are functionally different in PWS and PNS according to Barasch, Guitar, McCauley, and Absher (2000). The reduced reaction time in the ATM task is supported by the notion that there is an existing deficit in the auditory processing in persons who stutter. The NO responses were higher in the BAWNS shows that it was easy for BAWNS to detect the absence of the target rather than the presence of the target. Also, the reaction time was less when the target is in the initial position rather than the medial position. This is because initial position consumes most of the attention resources to check the presence or absence of the target phoneme/tone than when they are in the medial position. Good results in terms of accuracy could be because of their effective working memory skills with respect to tone (Hampton & Weber Fox, 2008)

However, persons who stutter have disruption in encoding signals which may contribute to decreased efficiency in processing and monitoring auditory signals during auditory feedback. Reduced efficiency in auditory feedback might lead to increased disruption in fluency (Rosenfield & Jerger, 1984; Kalinowski et al., 1993).

Phoneme Monitoring Task - Reaction Time and Accuracy Measures

Like ATM task, in PM task also BAWS (1525.70) took more time to correctly respond than BAWNS (1170.57) to identify the presence or absence of phoneme presented in the picture shown. The difference between the groups was significant ($|z| = 3.78, p < 0.05$). About accuracy, BAWNS (83.75) responded more accurately than BAWS (75.25). Though there was a difference in the response times between group that was not significantly different ($|z| = 1.03, p > 0.05$). With regard to YES and NO responses across groups it was found that BAWNS (83.75) have greater percentage of YES responses than BAWS (75.25). But, for NO responses BAWS (24.75) had greater percentage than BAWNS (16.25).

Similar results were obtained in the study done by Sasisekaran et al. (2006) indicating that PWS have longer reaction time in monitoring phonemes than PNS. However, there was no significant between-groups difference. In Indian context study performed by Sangeetha (2018) showed that the phoneme monitoring abilities of BAWS and BAWNS varied significantly. BAWS had more reaction time compared to BAWNS with statistical difference and concluded that BAWS have general monitoring deficits along with phonological encoding difficulties. Another study supporting the present study results is done by Sasisekaran et al. (2006) indicated that PWS significantly have low reaction time than PNS in phoneme monitoring of silent naming. Contrary to the above studies, Zhang and Xiao (2008) study revealed that the reaction time of PWS was almost the same as that of the PNS in Shengmu (initial consonants of Chinese syllables) monitoring but was significantly slower in Yunmu (simple or compound vowels of Chinese syllables). No significant between-group differences among all the tasks. The reaction time of phoneme monitoring of consonant in the initial position is similar for PWS and PNS, this difference might be due to the differences in

the structure of both languages. These studies support that the deficit is at the stage of phonological monitoring in BAWS along with deficits in general monitoring or ATM. These findings are in support to the psycholinguistic theories of stuttering that state phonological encoding as a causative component for dysfluencies in PWS (Wingate, 1988; Perkins et al., 1991; Postma & Kolk, 1993; Howell, 2004). The better performance of BAWNS than BAWS in PM task shows that persons with stuttering have difficulties in phonological encoding which proves that the cause of disfluencies can be linguistic in nature rather than motoric (Levelt & Wheeldon, 1994). Studies show that there is lexical access difference between PWS and PNS. Since familiarisation task which includes naming the stimuli performed before the task, it is conceivable that this would have eased the lexical access leading to less group difference. Also, the observed differences only account for the stages after the lexical access i.e., phonological processes.

In the current study, among accurate responses YES responses were more than NO responses. In PM task, BAWNS had more accurate NO responses and less accurate YES responses compared to BAWS. This shows that for BAWS monitoring to the presence of the target was easier than responding to the absence of the target. Among tasks a greater number of YES responses were seen in ATM task than PM task. This might be due to the simplicity of the ATM task. Similar results were seen in study done by Sasisekaran et al. (2006), Darshini (2014) showed that there was significant difference in silent naming task. Study by Sangeetha (2018) also showed that BAWS responses were less NO responses BAWNS.

Position Effect – Initial Position Vs Medial Position

For BAWS, in PM task the latency of reaction time in initial place (1372.12) is lesser than the latency of reaction time in medial (1612.11) place. In ATM task also the latency of reaction time in initial place (761.16) is lesser than the latency of reaction time in medial (835.63) place. In both the tasks the reaction time was faster when the target phoneme/tone is in the initial place ($|z| = 2.6, p < 0.05$) and slower when the target phoneme/tone is in medial place ($|z| = 2.8, p < 0.05$). For BAWNS, in PM task the latency of reaction time in initial place (1033.69) is lesser than the latency of reaction time in medial (1288.05) place. In ATM task also the latency of reaction time in initial place (501.96) is lesser than the latency of reaction time in medial (696.10) place. In both the tasks the reaction time was faster when the target phoneme/tone is in the initial place ($|z| = 2.8, p < 0.05$) and slower when the target phoneme/tone is in medial place ($|z| = 2.1, p < 0.05$). Among groups, In PM task statistical difference is seen in initial ($|z| = 3.69, p < 0.05$) and medial places ($|z| = 3.02, p < 0.05$). In ATM task significant difference is seen only in the initial place ($|z| = 2.04, p < 0.05$) not in the medial place ($|z| = 1.66, p > 0.05$).

In the same way in ATM task also the latencies of pure tone in initial and medial position of BAWS is more than BAWNS. The initial position values had no significant difference, but medial position values had significant difference. When the correct YES-initial and YES-medial responses were compared it was found that in BAWNS, the target in the initial position of both tasks have less response time than the target in the medial position and no significant difference is seen. Same kind of results were observed in BAWS across initial position and medial position, but the difference is not significant. In both the tasks, the reaction time to recognise the stimuli in initial position was lesser than the reaction time to recognise the stimuli for medial position. These

results agree with the study by Sasisekaran et al. (2006) in which the response time for the first position (C1) were better than the response time for latter positions. Costa and Caramazza (2002) stated that during speech production the phonological encoding of the segments in the first position happens prior to the encoding of the segments in second or third positions. To keep up this, study by Wheeldon and Levelt (1995) also stated that in speech production left to right succession of phonological encoding takes place. So, the present study supports the theories of successive enhancement of activation and encoding of phonological during speech production (Levelt et al., 1999; Sevald et al., 1994).

Phoneme Monitoring Task Vs Auditory Tone Monitoring Task

In both the groups, the reaction time of ATM task was better than PM task and are significantly different (BAWNS - $|z| = 2.70$, $p < 0.05$, BAWS - $|z| = 2.70$, $p < 0.05$). The accuracy of both the tasks were almost similar. For BAWS the accuracy by slightly higher in ATM task and in BAWNS the accuracy is slightly higher in PM task; the differences have no significant value (BAWNS - $|z| = 0.25$, $p > 0.05$, BAWS - $|z| = 2.70$, $p > 0.05$).

The participants had greater reaction time in PM task rather than ATM task. This was supported by the study done by Sangeetha (2018) which showed that bilingual adults who stutter performed well in ATM task than PM task. Also supported by studies done by Sasisekaran et al. (2006), Zhang and Xiao (2008). The assumptions for such results are thought to be due to the difference in the complexity of the tasks, the mode of the stimulus presentation and variations in the stimuli. Carrying out familiarisation test prior to the actual test might be also a reason for better reaction time in both the tasks. The stimuli used for PM task were ten target phonemes to monitor across sixteen

bisyllabic words, but in ATM task there was only one target tone i.e., 1kHz to monitor four patterns of two-tone sequences. Also, the number of stimulus items in PM task are forty whereas in ATM task they are only seven items. The PM task was more cognitively exacting than ATM task. In PM task the person is required to listen to the target phoneme, then look at the picture, recollect the name of the picture shown and check for the presence or absence of phoneme across two positions through silent naming. In ATM task, the person is only required to monitor a single tone across two tones, and both were presented auditorily. According to the models of speech production the cognitive demand posed for monitoring phonemes is greater than the demand for monitoring tones. The stages for production of speech involve retrieving the word, assigning word form segments (phonemes) and structure. This word before articulating is stored in the buffer and sent for monitoring. Then this inner speech is monitored in the conceptualiser (Levelt, 1989; Dell, 1986). Whereas in ATM task the series of pure tones are temporarily stored in short term memory and monitored. According to Baddeley (1992) the phonological information is handled by a phonological loop. Phonological loop is further divided into passive storage and active rehearsal mechanism. The auditory or speech related information is temporarily stored for a less time in the passive storage. It is believed that that phonological information is maintained for longer time than the auditory information (Baddeley, 2003). The modes of stimuli presented were different across tasks. In PM task, the target phoneme is presented aurally, and stimuli is presented visually in picture format whereas in ATM task, the target and stimuli both are presented aurally.

To conclude the whole discussion, BAWNS performed better than BAWS in ATM and PM tasks in terms of accuracy and speed. The ATM task was better performed than PM task in both the groups. This shows that BAWS had general deficits

along with specific phonological deficits. This delay in phonological encoding in BAWS may lead to the disturbances in the phonological processes causing temporal desynchronization responsible for the disfluencies in persons with stuttering.

Chapter VI

Summary and Conclusions

Stuttering is a disruption in the simultaneous and successive programming of muscular movements required to produce a continuous flow of speech. The major problem lies in the programming of sequence and timing (Van Riper, 1982). Later advances by Mackay (1982) focused primarily on the sentential and phonologic system which explains that the sequential activation of nodes at various levels is needed for the production of fluent speech, any disruption in the activation leads to disfluent speech. Postma and Kolk, 1993 proposed Covert Repair Hypothesis which explains that people who stutter make more significant numbers of phonological encoding errors, which are detected during the monitoring of inner speech and repaired. This deficit can cause disfluencies during the production of speech. Other psycholinguistics theories state that disruption in the phonological encoding can lead to disfluent speech.

The present study aimed to investigate the phonological encoding skills in bilingual adults who stutter in comparison with bilingual adults who do not stutter. Though there is literature on phonological encoding studies using phoneme monitoring paradigm on persons who stutter. There are very few studies done on bilinguals. The tasks administered in the present study are Phoneme Monitoring (PM) and Auditory Tone Monitoring (ATM) task using DMDX software via computer. The speed and accuracy of responses during these tasks were calculated and compared within and among groups. Twenty participants of age range 18-35 years have participated. It includes ten clinical subjects and ten control subjects. All the participants were bilinguals, the native language was Kannada, and the second language as English. They had a minimum social proficiency on the International Second Language Proficiency

Rating Scale (ISLPR, Wylie, & Ingram, 2010). The members in the clinical group had moderate to severe range of stuttering, evaluated by a Speech-Language Pathologist on the Stuttering Severity Instrument (SSI Version 4, Riley, 2009). The participants of the control group were age and gender-matched bilingual adults who do not stutter. Participants reported no history of intellectual, sensory (vision and hearing), neurological or other communication disorders. The cognitive skills were screened with the Montreal Cognitive Assessment (MoCA).

The PM and ATM tasks have two phases; the first phase includes preparation of stimulus and designing the task, whereas in the second phase task administration on participants is discussed. In PM, ten highly disfluent phonemes of Kannada were selected, and sixteen picturable bisyllabic words (CVCV) with the target consonants present in either initial or medial positions were selected. In total, forty test items were designed in which twenty pictures had target phoneme, thus needing a YES response and twenty pictures had no target phoneme thus needing a NO response. The Keys for 'YES' and 'NO' responses were assigned to left, and right keys on mouse/mousepad respectively and are colour coded, i.e., green for YES and red for NO. The individuals who were participating were familiarised with the sixteen stimuli pictures and their names through the naming task. They were explained that they would hear a phoneme, and after that, a familiarised picture would appear on the screen. The participants were instructed to press YES or NO immediately after looking at the picture.

The stimuli for ATM task were 1000 Hz and 500 Hz pure tones. The target tone in this task was 1kHz, and the two-tone sequences consisted of 1kHz-500Hz, 500Hz-1kHz, 1kHz-1kHz and 500Hz-500Hz combinations. A YES response was given if the target tone 1000 Hz was there in the two-tone sequence and NO response if it is absent. The test started with the appearance of a blank screen for about 500ms, followed by the

appearance of target 1 kHz pure tone. An inter-stimulus gap of 500ms was given, which is then followed by the appearance of the two-tone sequence. Immediately after the appearance of the two-tone sequence, the participants responded YES or NO. Before the presentation of the next item, an interstimulus gap of 500ms is given.

Overall, the data is not normally distributed in clinical and control groups for PM and ATM tasks. Hence, a non-parametric test, Mann Whitney and Wilcoxon Signed Ranks tests are considered to compare the speed and accuracy data of among and within groups, respectively. In ATM task, that BAWS has greater reaction time than BAWNS, and significantly different between groups. With regard to accuracy, BAWNS responded more accurately in ATM task than BAWS, and the difference was not significant among groups. In PM task also, BAWS has greater reaction time than BAWNS and difference found was significant. In terms of accuracy, BAWNS responded more accurately than BAWS and significant difference is not seen. It was found that for both the tasks among correct responses, YES responses were more than NO responses. It was easy for the participants to identify the presence of the phoneme/tone rather than the absence of the phoneme/tone. Among groups, YES responses were higher in BAWNS, and NO responses were higher in BAWS. Among groups, BAWNS have the highest number of correct YES responses than that of BAWS. This difference was not statistically significant in both the PM task and ATM task. With respect to the position in BAWS, among both the tasks the reaction time was faster when the target phoneme/tone is in the initial place and slower when the target phoneme/tone is in medial place. Similar patterns were seen in BAWNS, and the reaction time was faster when the target phoneme/tone is in the initial place and slower when the target phoneme/tone is in medial place. The statistical difference is seen among tasks in both places. No group effect is seen regarding the place. Among groups,

statistical difference is seen among both the places in PM task; in ATM task, the significant difference is seen only in the initial place. Lastly, in both groups, the reaction time of the ATM task was significantly better than the PM task. The accuracy of both the tasks was almost similar, and the difference has no significant value.

The results for the present study show that BAWNS took more time to identify the presence or absence of the target consonant/tone when compared to BAWS. Similarly, BAWNS had a higher number of correct responses than BAWS. Across tasks, the reaction time was less for ATM task and more for PM task. This significant difference might be due to the complexity in the stimulus of the PM task. Such a difference is not found for accuracy between tasks. BAWS and BAWNS have performed equivalently across tasks in terms of accuracy. With respect to position of target, the reaction time was less when it is in initial place than medial place. This difference was similar across tasks, and the difference was significant except for medial position in ATM task.

Clinical Implications

- This study shows the extent of variation of phonological encoding in L1 of bilingual adults who stutter from who do not stutter.
- The present study findings are in support of psycholinguistic theories related to stuttering.
- This study shows persons who stutter have a breakdown in the phonological encoding stage.
- This study has escalated the scope of phonological encoding skills in the assessment and treatment approaches of stuttering.

- This present study has chosen bilingual adults as subjects, as the majority of the population being bilinguals these days with a minimum proficiency in English.
- This study proved that the phoneme monitoring paradigm could be used to rule out the deficits in phonological encoding.
- This study shows the need to implement testing of phonological encoding skills during a fluency assessment.
- This study increases the scope of strengthening phonological encoding abilities in treatment.

Limitations

- For the present study to be validated, it must be carried out on larger populations.
- The complexity and number of items in the ATM task could have been increased using pure tones of other frequencies.
- The present study could have compared phonological encoding across various severities.
- All the phonemes of Kannada were not incorporated due to time constraints.

Future directions

- The present study can be done on a larger population.
- The present study can be done across age groups to see the developmental trend of phonological encoding skills.
- A study to check the variations in phonological encoding across different proficiencies can be performed.
- A study can be done on all the phonemes in Kannada, to the variations among them.

References

- Aruna Kamath. (2001). Cognitive-Linguistic Assessment Protocol. An unpublished dissertation submitted to university of Mysore; Mysore.
- Baddeley, A. (1992). Working memory. *Science*, 255(5044), 556-559.
- Baddeley, A. (1992). Working memory: The interface between memory and cognition. *Journal of cognitive neuroscience*, 4(3), 281-288.
- Baddeley, A. (2003). Working memory and language: An overview. *Journal of communication disorders*, 36(3), 189-208.
- Barasch, C. T., Guitar, B., McCauley, R. J., & Absher, R. G. (2000). Disfluency and time perception. *Journal of speech, language, and hearing research*, 43(6), 1429-1439.
- Brocklehurst, P. H. (2008). A review of evidence for the covert repair hypothesis of stuttering. *Contemporary Issues in Communication Science and Disorders*, 35(Spring), 25-43.
- Brown, S. F. (1945). The loci of stuttering in the speech sequence. *Journal of Speech Disorders*, 10(3), 181-192.
- Byrd, C. T., Coalson, G. A., Yang, J., & Moriarty, K. (2017). The effect of phonetic complexity on the speed of single-word productions in adults who do and do not stutter. *Journal of communication disorders*, 69, 94-105.
- Coalson, G. A., & Byrd, C. T. (2018). Delayed silent phoneme monitoring in adults who do and do not stutter. *Speech, Language and Hearing*, 1-18.

- Costa, A., & Caramazza, A. (2002). The production of noun phrases in English and Spanish: Implications for the scope of phonological encoding in speech production. *Journal of Memory and Language*, 46(1), 178-198.
- Damian, M. F., & Martin, R. C. (1999). Semantic and phonological codes interact in single word production. *Journal of Experimental Psychology: Learning, Memory, and Cognition*, 25, 345–61.
- Darshini K.J. (2015). Phonological Encoding in Persons with Stuttering through Phoneme Monitoring Tasks. An unpublished dissertation submitted to university of Mysore; Mysore.
- Dell, G. S. (1986). A spreading activation theory of retrieval in sentence production. *Psychological Review*, 93, 283–321.
- Dell, G. S. (1988). The retrieval of phonological forms in production: Tests of predictions from a connectionist model. *Journal of Memory and Language*, 27, 124–42.
- Duyck, W., Van Assche, E., Drieghe, D., & Hartsuiker, R. J. (2007). Visual word recognition by bilinguals in a sentence context: Evidence for nonselective lexical access. *Journal of Experimental Psychology: Learning, Memory, and Cognition*, 33(4), 663.
- Gathercole, S. E., Willis, C. S., Emslie, H., & Baddeley, A. D. (1992). Phonological memory and vocabulary development during the early school years: A longitudinal study. *Developmental psychology*, 28(5), 887.

- Gonçalves, I. C., Andrade, C. R. F., & Matas, C. G. (2015). Auditory processing of speech and non-speech stimuli in children who stutter: electrophysiological evidences. *Brain Disord Ther*, 4(5), 199.
- Hampton, A., & Weber-Fox, C. (2008). Non-linguistic auditory processing in stuttering: evidence from behavior and event-related brain potentials. *Journal of fluency disorders*, 33(4), 253-273.
- Hartsuiker, R. J., & Kolk, H. H. J. (2001). Error monitoring in speech production: A computational test of the perceptual loop theory. *Cognitive Psychology*, 42, 113–57.
- Hartsuiker, R. J. (2002). The addition bias in Dutch and Spanish phonological speech errors: The role of structural context. *Language and Cognitive Processes*, 17, 61–96.
- Hartsuiker, R. J., Bastiaanse, R., Postma, A., & Wijnen, F. (Eds.). (2005). *Phonological encoding and monitoring in normal and pathological speech*. Psychology Press.
- Howell, P. (2004). Assessment of some contemporary theories of stuttering that apply to spontaneous speech. *Contemporary issues in communication science and disorders*, 31(Spring), 123-140.
- Howell, T. A., & Ratner, N. B. (2018). Use of a phoneme monitoring task to examine lexical access in adults who do and do not stutter. *Journal of fluency disorders*, 57, 65-73.
- Indefrey, P., & Levelt, W. J. (2004). The spatial and temporal signatures of word production components. *Cognition*, 92(1-2), 101-144.

- Jacobs, A. E. (2016). Phonological Encoding of Medial Vowels in Adults Who Stutter.
- Kalinowski, J., Armson, J., Stuart, A., & Gracco, V. L. (1993). Effects of alterations in auditory feedback and speech rate on stuttering frequency. *Language and Speech, 36*(1), 1-16.
- Kalinowski, J., Stuart, A., Sark, S., & Armson, J. (1996). Stuttering amelioration at various auditory feedback delays and speech rates. *International Journal of Language & Communication Disorders, 31*(3), 259-269.
- Kashyap, P., & Maruthy, S. (2020). Stuttering frequency and severity in Kannada-English balanced bilingual adults. *Clinical Linguistics & Phonetics, 34*(3), 271-289.
- Levelt, W.J.M. (1983). Monitoring and self-repair in speech. *Cognition, 14*, 41-104.
- Levelt, W.J.M. (1989). *Speaking: From intention to articulation*. Cambridge, MA: MIT press.
- Levelt, W.J.M, Roeloffs, A., & Meyer, A.S. (1999). A theory of lexical access in speech production. *Behavioral and Brain Sciences, 22*, 1-75.
- Levelt, W.J.M., & Wheeldon, L.R., (1995). Monitoring the time course of phonological encoding. *Journal of Memory and Language, 34*, 311-334.
- Lim, V. P., Lincoln, M., Chan, Y. H., & Onslow, M. (2008). Stuttering in English–Mandarin bilingual speakers: The influence of language dominance on stuttering severity. *Journal of Speech, Language, and Hearing Research*.

- Marques, C., Moreno, S., Luís Castro, S., & Besson, M. (2007). Musicians detect pitch violation in a foreign language better than nonmusicians: behavioral and electrophysiological evidence. *Journal of Cognitive Neuroscience, 19*(9), 1453-1463.
- Meyer, A. S., & Damian, M. F. (2007). Activation of distractor names in the picture-picture interference paradigm. *Memory & cognition, 35*(3), 494-503.
- Nasreddine, Z. S., Phillips, N. A., Bédirian, V., Charbonneau, S., Whitehead, V., Collin, I., & Chertkow, H. (2005). The Montreal Cognitive Assessment, MoCA: a brief screening tool for mild cognitive impairment. *Journal of the American Geriatrics Society, 53*(4), 695-699.
- Pelczarski, K. M., Tendra, A., Dye, M., & Loucks, T. M. (2019). Delayed Phonological Encoding in Stuttering: Evidence from Eye Tracking. *Language and speech, 62*(3), 475-493.
- Pelczarski, K. M., & Yaruss, J. S. (2014). Phonological encoding of young children who stutter. *Journal of fluency disorders, 39*, 12-24.
- Perkins, W. H., Kent, R. D., & Curlee, R. F. (1991). A theory of neuropsycholinguistic function in stuttering. *Journal of Speech, Language, and Hearing Research, 34*(4), 734-752.
- Postma, A., & Kolk, H. H. J. (1993). The covert repair hypothesis: prearticulatory repair processes in normal and stuttered disfluencies. *Journal of Speech and Hearing Research, 36*, 472-87.
- Riley, G., & Bakker, K. (2009). *SSI-4: Stuttering severity instrument*. PRO-ED, an International Publisher.







- Roelofs, A. (1997). The WEAVER model of word-form encoding in speech production. *Cognition*, 64(3), 249-284.
- Rosenfield, D. B., & Jerger, J. (1984). Stuttering and auditory function. *Nature and treatment of stuttering: New directions*, 73-87.
- Mahesh, S., Amulya, S., Taj, S., & Geetha, M. P. (2019). Auditory Tone Monitoring in Adults with Stuttering. *Research & Reviews: A Journal of Bioinformatics*, 6(2), 16-25.
- Sangeetha M. & Geetha M.P. (2017). Phonological encoding in children who stutter. ARF project, All India Institute of Speech and Hearing, Mysore.
- Sangeetha M. (2018). Phonological encoding abilities in bilingual adults who stutter. ARF project, All India Institute of Speech and Hearing, Mysore.
- Sasisekaran, J., Luc, F., Smyth, R., & Johnson, C. (2006). Phonological encoding in the silent speech of persons who stutter. *Journal of Fluency Disorders*, 31(1), 1-21.
- Sasisekaran, J., & Luc, F. (2006). Phoneme monitoring in silent naming and perception in adults who stutter. *Journal of Fluency Disorders*, 31(4), 284-302.
- Sasisekaran, J., Brady, A., & Stein, J. (2013). A preliminary investigation of phonological encoding skills in children who stutter. *Journal of fluency disorders*, 38(1), 45-58.







- Sasisekaran, J. (2014). Exploring the link between stuttering and phonology: A review and implications for treatment. In *Seminars in speech and language* (Vol. 35, No. 02, pp. 095-113). Thieme Medical Publishers.
- Sevald, C. A., & Dell, G. S. (1994). The sequential cuing effect in speech production. *Cognition*, 53(2), 91-127.
- Shattuck-Hufnagel, S. (1979). Speech errors as evidence for a serial-order mechanism in sentence production. In W. E. Cooper & E. C. T. Walker (Eds.), *Sentence processing: Psycholinguistic studies presented to Merrill Garrett* (pp. 295–342). Hillsdale, NJ: Lawrence Erlbaum Associates, Inc.
- Sindhu Priya & Santhosh M. (2016). Lexical access in bilingual adults who stutter. An unpublished dissertation submitted to university of Mysore; Mysore.
- Shishira S. (2019). Phonetic influences in Kannada speaking adults who stutter. An unpublished dissertation submitted to university of Mysore; Mysore.
- Stemberger, J. P. (1983). Speech errors and theoretical phonology: A review. Indiana University Linguistics Club.
- Stemberger J. P. (1990). Wordshape errors in language production. *Cognition*, 35, 123–57.
- Van Riper, C. (1982). *The nature of stuttering*. Prentice Hall.
- Vigliocco, G., & Hartsuiker, R. J. (2002). The interplay of meaning, sound, and syntax in sentence production. *Psychological Bulletin*, 128, 442–72.
- Vincent, I., Grela, B. G., & Gilbert, H. R. (2012). Phonological priming in adults who stutter. *Journal of fluency disorders*, 37(2), 91-105.

- Wheeldon, L. R., & Morgan, J. L. (2002). Phoneme monitoring in internal and external speech. *Language and cognitive processes, 17*(5), 503-535.
- Wingate, M. (1988). *The structure of stuttering*. New York: Springer Verlag.
- Wingate, M. E. (1967). Stuttering and word length. *Journal of Speech and Hearing Research, 10*(1), 146-152.
- Wylie, E., & Ingram, D. E. (2010). *International second language proficiency ratings: general proficiency version for English*. ISLPR Language Services.
- Zhang, J., & Xiao, E. (2008). Phonological encoding in the silent speech of persons who stutter. *Acta Psychologica Sinica, 40*(03), 263-273.

Appendix

S.No	Phonemes	Initial	Final
1.	/D/	 <p>/d̪o:lu/</p>	 <p>/mo:d̪a/</p>
2.	/T/	 <p>/t̪o:pi/</p>	 <p>/lo:t̪a/</p>
3.	/r/	 <p>/ruʃi/</p>	 <p>/sara/</p>
4.	/p/	 <p>/pu:ri/</p>	 <p>/t̪o:pi/</p>

5.	/g/	 /gu:be/	 /mu:gu/
6.	/c/	 /tʃa:ku/	 /pa:tʃi/
7.	/t/	 /təle/	 /ko:ti/

8.	/v/	 <p data-bbox="715 600 794 633">/vi:ne/</p>	 <p data-bbox="1118 600 1193 633">/ki:vi/</p>
9.	/k/	 <p data-bbox="715 1077 794 1111">/ki:vi/</p>	 <p data-bbox="1102 1077 1209 1111">/tʃa:ku/</p>
10.	/s/	 <p data-bbox="715 1514 794 1547">/sa:ra/</p>	 <p data-bbox="1110 1514 1193 1547">/hasu/</p>