

GUIDELINES FOR PURCHASE AND INSTALLATION OF E.R.A.

Reg.No.M9111

AN INDEPENDENT PROJECT IN PART FULFILMENT FOR THE FIRST YEAR  
M.Sc.(SPEECH AND HEARING) SUBMITTED TO UNIVERSITY OF MYSORE.

ALL INDIA INSTITUTE OF SPEECH AND HEARING: MYSORE - 570 006.

1992

Dedicated to 'Aai' and 'Dada'

"Without whom I am not"

and to my loving grandma.

**CERTIFICATE**

This is to certify that the Independent Project entitled: **Guidelines for Purchase and and Installation of E.R.A** has been prepared under my supervision and guidance.

Mysore

1992

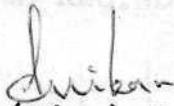
  
Dr. (Miss) S. Nikam,  
GUIDE

**CERTIFICATE**

This is to certify that the Independent Project entitled: **Guidelines for Purchase and Installation of E.R.A.** is the bonafide work in part fulfilment for M.Sc, in Speech and Hearing of the student with Reg.No.M9111.

Mysore

1992

All

India



Director

Institute

of

Speech and Hearing, Mysore.

### DECLARATION

This Independent Project entitled:  
**Guidelines for Purchase and Installation  
of E.R.A.** is the result of my own study  
undertaken under the guidance of Dr.(Miss)  
S.Nikam, Prof, and Head of the Department  
of Audiology, All India Institute of  
Speech and Hearing, Mysore and has not  
been submitted earlier at any University  
for any other Diploma or Degree.

Mysore

1992

Reg.No.M9111

## ACKNOWLEDGEMENTS

- \* I am deeply indebted to Dr.(Miss) S.Nikam, Prof, and Head of the Department of Audiology,A.I.I.S.H. Mysore for her invaluable guidance, encouragement and patient listening. But for her suggestions, comments and criticisms, this project would not have been possible.
- \* I would like to thank Dr.(Miss)S.Nikam, Director, AIISH, Mysore for permitting me to take up this project.
- \* Thanks to Mrs.C.s.Vanaja, for her encouragement, helpful suggestions and constant help at every phase of this work.
- \* Special thanks to Dr's M.N.Nagaraj, K.C.Ravishankar and Mr.Chandrashekar, for patiently answering my queries.
- \* To Prof. Jagadeesh and all my teachers who have laid the corner stone of audiology in my career.
- \* To Suchi and Rains - for helping me get over my bad moods by the constant chatter and giggles, as well to my other Ashianites - Zaver, Sanyu, Pitu, Swathi who are always concerned about my health. Its feels great to belong to a group so diverse but still united.
- \* A big thanks to all my classmates for their timely help, assistance, advice and co-operation.
- \* To Sangita, K. Shara, Zhappu for having helped me at various stages of this work.
- \* Thanks to Pragna, Jyoti, and Nandini for extending their help and support whenever needed.
- \* Thanks to Akka for doing a wonderful and pains taking job in preparation of this manuscript.
- \* Above all thanks to Lata, Deepak, Bhavaji and Dipli-for your silent prayers and blessings for success in all my endeavours and the unquestioning love you'll shower on me.
- \* Last but not the least my 3 little darlings - Payal, Tanvi and Babush. The pleasant memories of your innocent looks, laughter and sweet talks kept refreshing me at every stage of this work.

## TABLE OF CONTENTS

|   | <u>Page No.</u> |
|---|-----------------|
| I. Introduction   | 1 - 7           |
| II. History, Development and Clinical Applications of ERA           | 8 - 24          |
| III. Apparatus for ERA  |                 |
| (A) General apparatus   |                 |
| (B) Apparatus specific to different evoked R.A. Systems             | 25 - 42         |
| IV. Test environment and Installation procedures for ERA equipment. |                 |
| (A) General procedures  |                 |
| (B) Specific procedures   | 43 - 56         |
| V. Consideration for procurement of an ERA system                   | 57 - 72         |
| VI. Conclusions   | 73 - 74         |
| VII. Bibliography   | 75 - 78         |

## INTRODUCTION

The decade of the Eighties will be remembered by clinicians and scientists as the era of evoked potential measurement. The application of signal averaging technique has influenced nearly every area of science.

Signal averaging has opened untold avenues and created new vistas for examining the neural physiology of all sensory systems.

"It has been almost 200 years since Galvani discovered the electrical activity of biological tissue. Today we are able to apply this fundamental discovery to the entire auditory system. In the field of hearing and audition the use of evoked potentials has had tremendous influence on all of us working with hearing-impaired patients or searching for the missing pieces in normal auditory physiology. Every patient, infant, child or adult, no matter how impaired, can now have the auditory system objectively evaluated. Many of these patients in the past, could not be tested by psychophysical techniques or would have to wait many years before their auditory systems could be assessed. Consequently the infant would lose the critical years for language development" (Gibson and Ruben (1978)).

The decade of the 1960s was particularly significant in the development of auditory evoked potentials (AEPs).

The 1970s were dominated by investigation and clinical application of the "auditory brainstem response"(ABR) first

recorded by Sohmer and Feinmesser (1967) and later described by Jewett and Williston (1971). With the development of ABR short latency evoked potentials, our accuracy in detection of auditory pathway lesion has increased tremendously; confirmation of hearing loss in infants has become a practical reality leading to earlier intervention than ever before possible, auditory testing of difficult patients, such as multiply handicapped children and functional hearing loss patients, has become a routine in daily clinical activity. In short, the use of auditory brain stem responses has become a mandatory piece of the current audiologic test battery.

Today, with the ease of recording auditory evoked potentials and the relatively inexpensive investment required, many clinical programs have added the ABR to the clinical neurophysiological armamentarium.

The last decade has brought an appreciation of the variety of auditory evoked potentials (AEPs) as well as a great deal of research into their comparative merits as clinical tools in audiology, otoneurology and neurology.

Manufacturers have enthusiastically entered the competitive market place, producing an array of instrumentation and associated software. This contribution has done much to bring electrophysiological measures from the realm of experimental research to routine clinical use.

Considering the clinical applicability and usefulness of ERA, once a decision has been made to buy the equipment, the next question that arises is in which of the equipments would be ideal and economical for the particular set-up. In most cases, the buyer has to live with the instrument chosen for many years and no one wants to be responsible for a poor choice, but in a new set-up the buyer has to make purchase decision taking into consideration a number of factors such as -

- a) Cost of the equipment and the budget available
- b) Type of caseload for which the equipment is to be used  
eg. is the ERA to be used for assessing hearing status, assessing integrity of CHS.
- c) Type of set-up for which the equipment is to be used ie. whether a private clinic, an academic institute, or a medical set-up.

Various motivational factors come into play when deciding to purchase test equipment.

- How does one choose an equipment most appropriate for the specific needs of the particular set-up?
- Where can one turn for assistance in this decision making process?

Factors pertaining to technical specifications such as the number of channels, intensity range, menu available, ease

of operation etc. are to be compared across various instruments before arriving at a decision. Sometimes a machine may offer more than what we actually need for audiological purposes. In such cases, we may have to ascertain whether the additional cost of the optional accessories is justifiable, otherwise one could carry on without the need of such accessories.

Special instrument distributors (SIDs) are a good one stop source for discussing equipment needs.

The following questions may need to be answered to facilitate decision making.

- What tests does the equipment have facilities for?

Whether all standard tests - Brainstem audiometry. Cortical evoked response, MLR, ECoChG, LLR, CNV etc.

- How many input channels does the equipment have?

One or multichannel input depends on the type of investigation to be performed. In most cases, one channel will do, but a feature of two channels may be convenient for certain latency measurements. Both ipsilateral and contralateral recordings can be obtained simultaneously with two channel instruments.

- How are the test results presented on the screen and print-out?

Some equipments may provide print-outs containing traces, markers, latency and amplitude information as well as details of both acquisition and stimulus parameters and can be recorded and kept with each test or test run. This facility would be advantageous in large set-ups and in research activity.

-Portability:

If the instrument has to be placed in one place, the size may not matter. If however, it is necessary to carry it from department to department be it E.N.T., Audiology, Paediatrics, or Operating room, then it is wise to opt for a small, light weight equipment.

Auditory evoked potentials have gained audiologic prominence partially because of their objective nature. That is no overt response is required from the subject. However, the identification and interpretation of AEPs require considerable skill and judgement on the part of the examiner. An accurate assessment can only be accomplished through an understanding of the underlying physiological events, the recording procedures used, the effects of numerous technical, methodologic and pathophysiologic variables which may influence the results and in relation to a comprehensive normative data base.

As is the case for any electrical equipment, one must first become familiar with the parts before utilising it. Also of great importance is the need to emphasize on installation procedures, as factors such as electrical interference acoustic interference, environmental conditions can effect or distort the results of the test and can even reduce the life of the equipment.

The patients environment should ideally be electrically shielded, acoustically isolated enclosure. Sometimes testing in more adverse environments such as operating room or an intensive care unit is unavoidable, with consequent limitations due to environmental sound levels and electrical interference.

ERA has two main clinical applications -

- a) A means of estimating hearing acuity
- b) A method of diagnosis - identifying the cause of a hearing defect or detecting some lesion which is affecting the auditory system.

Evoked response techniques have not only been of interest to audiologists and neurologists but have also claimed attention from other professionals as otorhinolaryngologists, paediatricians, speech-language pathologists, general physicians and other allied professionals.

Here an attempt has been made to cover the available materials on ERA with the following aims.

- a) To provide the reader with the information regarding factors that need to be considered for procuring the ERA instrument.
- b) To provide the reader the necessary guidelines for installing the equipment following its purchase.

## HISTORY, DEVELOPMENT AND CLINICAL APPLICATIONS OF ERA

### What are 'Evoked Potentials'?

It has been known for long that sensory stimulation elicits (electric) potentials from different parts of the nervous system. Such potentials which are elicited in response to stimulation have been termed 'evoked' potentials in contrast to those which can be picked up from different parts of the body without any apparent stimulation. Among the latter are the 'resting' potentials of the cochlea and the spontaneous EEC potentials. Depending upon the stimulus modality we can have auditory, visual and somatosensory evoked potentials.

Evoked potentials testing is now-a-days a very popular non-invasive technique, daily applied by clinicians as a powerful tool for obtaining objective information on the functional integrity of the main sensory and neural pathways. Evoked potentials are very small changes in the bioelectric activity elicited by auditory, somatosensory and visual stimuli.

Recording of evoked potentials is normally obtained by means of surface electrodes placed in the proximity of the generator under investigation.

E.Ps are generally mixed with large amplitude EEC and EMG activities and therefore not visible without computer enhancement, this is accomplished by delivering multiple stimuli and recording many responses. This allows the averaging computer to extract the stimulus - locked responses from the physiological background noise.

### **Evoked Response or Electric Response:**

The term 'electric response audiometry' was accepted at the 2nd meeting of the International ERA study group in Vienna in 1971 as the general term for all audiometry that uses as an end point any one of a considerable number of electric responses that can be evoked by acoustic stimulation.

The original term 'evoked response audiometry' was thought in exact as it can be reasonably be said that any test of hearing which produces a reaction from the patient, either objectively or subjectively is a form of 'evoked response audiometry' and therefore, the word 'evoked' is redundant. The use of the word 'electric', on the other hand, is more precise as it is the bio-electric responses from the patient which are measured in ERA.

In spite of these, the term evoked response has been more popular and the abbreviation AER stands for averaged evoked/electric response.

There are different electric response produced by auditor/systems on its stimulation. Most of these arises in the central nervous system but others are generated in the ear itself and still others are reflex responses in muscles.

The history and development of ERA is dated back to 1875 when cat on recorded electrical changes in the exposed brain of rabbits and monkeys. However, it was only as late, as 1929, when Berger recorded the first human electroencephalogram (EEG) from electrodes placed on scalp. Following Berger's work, several workers attempted to identify specific changes in the EEG in response to tactile, visual or auditory stimulation but their work was hampered since the specific changes were largely obscured by the background..fluctuations of the other EEG waves. It was the introduction of electronic avecaging techniques that entirely revolutionised the science of electric response audiometry (ERA). This allows the experimenter to accumulate as many responses as she wishes. Hence, the response grows larger as it is a time-locked phenomenon, while the/background fluctuations being random in nature, cancel themselves out. Further improvement came from the efforts of work done by Clark et al. (1962). They, developed an average response computer. This device converts analog data into a digital form from which averages, amplitudes and time histograms can easily be computed.

The different types of auditory evoked potentials used now-a-days are -

**ECochG:**

Pioneers were Wever and Bray (1930). They discovered the 'cochlear microphonics' in animals by placement of an electrode in the auditory nerve of the cat and thereby detecting an electric potential that accurately reproduced the frequency and waveform of the sound stimulus.

It is generally acknowledged that the first recording of human CM was reported by Fromm et al. in 1935.

Perhaps the most significant factor in the development of clinical ECochG to the current era was the application of signal averaging techniques, which allowed for non-surgical recordings (Ronis, 1966). ECochG involves recording the electrical activity of the cochlear and first order eight nerve fibers. The response to be detected are composed of the potentials of CM, AP and SP. ECochG has become an important tool in the identification, assessment and monitoring of certain otological and audiological disorders. Electrocochleography provides two distinct information. Firstly, it provides a reliable indication of the cochlear output which is not affected by sedation or by masking problem.

Secondly, it offers a unique insight into the physiology of the cochlea and may be used to learn more about the nature of particular causes of hearing dysfunction.

In the earlier days action potential (AP) would be recorded by placement of electrode on the promontory. Responses obtained from promontory approach were thought to be more reliable than electrode placement in other regions (Aran et al. 1969; Portman et al. 1967, 1968; Yoshie and Yamura, 1969). However, in case of promontory approach, in order to pierce the tympanic membrane local or general anesthesia was needed hence it was felt that the procedure was too aggressive to/justify its use as a diagnostic procedure.

The other approach was electrode placement on the external acoustic meatus (Coats and Dickey, 1970; Yoshie et al. 1967). But it was felt that piercing the meatal wall is as painful as piercing the tympanic membrane.

Cullen et al. (1972) demonstrated that it was possible to obtain potentials from the surface of the tympanic membrane without piercing it. Placing an electrode on the surface of the tympanic membrane requires more surgical skill than simply piercing it and is obviously not suitable for testing young children without using sedation. Keidel

(1971), Sohmer and Feinmesser (1970), and Jewett and Williston (1971) and Hecox and Galambos (1974) demonstrated that it was possible to measure AP from the first order. Cochlear nerve fibres and record cochlear microphonics by electrode placement on the hard palate, earlobe and the mastoid respectively.

These recordings offer for more than measurement of cochlear function as it is possible to obtain a series of waves with longer latencies which arise from important areas within the brainstem.

This led to the development of auditory brain stem response audiometry.

One of the most significant contributions of brainstem audiometry has been the reliability and repeatability of the obtained response. It appears to be extremely stable both for intersubject and intrasubject measurement. It is felt that the five wave forms obtained in the ABR reflect action potential from different sites in the brainstem from first order cochlear nerve fibres to the inferior colliculus.

Thus BER has great neurological significance as they demonstrate the course of the auditory response through the important brainstem areas and may reveal the site of any pathology which disrupts this passage. The major disadvantage of the BAER is that the acoustically transduced click is

broad-band in its frequency spectrum. Consequently, click-elicited BAERs provide minimal information regarding auditory sensitivity at specific test frequencies, especially in the low and middle frequencies. This disadvantage has been virtually eliminated by utilizing the BAER procedure known as the slow-negative-10 (SN 10) response (Davis and Hirsh, 1979).

The SN 10 response is a scalp-negative potential that can be elicited using tone burst stimuli centered at specific frequencies. This response now appears to be the method of choice for generating a physiologically based audiogram.

For almost two decades between 1963 and 1970, many workers concentrated on the measurement of the slow evoked auditory response which is cortical in nature.

Davis, Hirsch, Shelnuttt and Bowers (1967) found the CER to be useful in determining the subjective hearing thresholds within a few decibels given only the passive cooperation of the subject.

Researchers have attempted to discover whether or not the cortical evoked response has any value in revealing the cause or level of hearing dysfunction. However, there is no definite criteria for using CERA data for otoneurological disorders.

Middle and late responses are acoustically elicited electrical events that originate within higher neural structures than does the BAER and probably represent dendritic activity. Following stimulus presentation the middle response occurs within 15-40 ms. and the late response within 50-300 ms (Davis and Owen, 1985).

There are several audiological advantages to using these responses. First, both responses can be elicited by Clicks and tonebursts. Second, both responses can be elicited by low frequency tone bursts (ie 250 Hz) which is an obvious advantage when developing a physiologically based audiogram.

In contrast to the late components, the origin of the MLR has been the source of continuing debate and has seriously hampered the development of a clinical testing technique.

First reported by Geisler et al. (1958), it was supposed that they were cortical in origin, or neurogenic. Brickford et al. (1964) on the other hand attributed the activity to myogenic origins from the muscles of the head and neck. Ruhm et al.(1967) and Harker et al.(1977) support the neurogenic origin of the MLR, at least to moderate or low level stimuli.

Moushegian, Rupert and Stillman (1973) were the first to obtain frequency following response in man and it was thought that because of its low frequency responsivity, it was thought that FFR could provide information on the frequency range where ECoG and BSERA have limitations.

Walter et al. (1964) reported the very slow potential changes known as the contingent negative variation (CNV), and gave their first important description of the CNV response in man. Burian, Gestring and Haider (1969) related the CNV to meaningful words and have suggested that it may be used as an objective test for word discrimination.

### Clinical Applications of Evoked Potentials Testing

Evoked potentials testing is now-a-days a very popular non-invasive technique, daily applied by clinicians as a powerful tool for obtaining objective information on the functional integrity of the main sensory and neural pathways. Evoked potentials supplies measurements of neural responses especially in individuals unable or unwilling to cooperate such as young children, people with learning disabilities, malingerers and patients with neurological disorders.

Audiology, Otology, Otolaryngology, Neurology, Neurosurgery, Neonatology are some of the fields that can best take advantage of evoked potentials testing.

Price and Goldstein (1966) found good agreement between audiometric and evoked response thresholds for the normal and hard-of-hearing children. Evoked response audiometry suggested better hearing than did behavioural audiometry on about half the multiply handicapped children. They found that ERA is of value not only in testing normal and hard-of-hearing children, but also in evaluating young children with auditory perceptual problems not due to end organ deficits.

ERA can be successfully used in the following situations:

- (A) In the clinic - standardized ERA testing allow rapid evaluation of patients, this means the possibility of answering with a highly efficient method, the many queries normally put forward in order to reach an exact diagnosis.

- (B) In the operating theatre - ERA is used as an intraoperative procedure in many surgical cases ie for monitoring the functional integrity and the recovery of the sensorineural pathways during the removal of acoustic tumours or during other surgical corrections.
- (C) In the intensive care unit - Evoked response audiometry provides highly valuable diagnostic and prognostic information on the functional integrity of the sensory pathways of patients under intensive care due to trauma caused by head or spinal cord injuries etc.
- (D) In private practice - ERA is very helpful as a test for differential diagnosis of pathologies affecting the peripheral and central sensory pathways\* for threshold determination and hearing aid evaluation.

### **Clinical Application of ERA:**

Neonatology and Pediatrics -

- \* Auditory threshold determination
- \* Differential diagnosis of peripheral and central pathologies
- \* CNS maturation and degeneration
- \* Brainstem lesions.

Oto-neurology

- \* Diagnosis, prognosis and monitoring of pathologies affecting the facial nerve ie Bells palsy etc.
- \* Study of trigeminal nerve pathologies.

Oto-neurosurgery -

- \* Monitoring functional integrity of the auditory pathway during posterior fossa surgery

Otology

- \* Study of acoustic pathway lesions
- \* Differential diagnosis of cochlear and retrocochlear pathologies.

Audiology -

- \* Determination of degree and type of hearing loss.

Neurology and Neurosurgery -

- \* Diagnostic and prognostic evaluation of comatose patients.
- \* Brain death
- \* Demyelinating diseases
- \* Localization of tumors in the optic pathway, spinal cord and brainstem
- \* Differential diagnosis of peripheral and central pathologies.
- \* Monitoring of neurosurgical procedures.

**Clinical Applications of ABR**

- The ABR is a valid and reliable test of measuring threshold in a vast majority of cases.
- The ABR is recordable almost without exception from adults and children as young as 33 weeks gestational age (Galambos, 1977).

Consequently, ABR has been advocated as a valuable hearing screening procedure in the neonatal intensive care unit (ICU), where the incidence of significant hearing-impairment is estimated to be as high as 8-20% (Resor, 1988).

- Persistent absence of ABR has been recorded in infants with clinical evidence of brainstem dysfunction with apparently normal hearing (stockard et al. 1983). The ABR as a measure of central auditory transmission has been used in the neonatal ICU in assessing the integrity of brainstem structures particular vulnerable to the usual perinatal stresses such as dysphyxia and hyperbilirubinemia.
- The ABR may be used for differentiating cochlear from retrocochlear lesion.
- The ABR may be used as a prognostic indicator in comatose patients. A normal ABR may indicate good neurologic/cognitive outcome.
- ABR is found useful in confirming parenchymal lesions of the brainstem seen or not seen on radiologic studies (CT and MRI). It thus provides a different technologic probe to cross-check abnormalities suggested on clinical or radiologic grounds.

The test can yield important information and complement other modes of neuro-diagnosis.

- The ABR in combination with other tests is useful in differentiating diffuse lesions, such as those associated with multiple sclerosis, from more focal lesions such as tumour.
- The ABR may be used as a prognostic indicator in comatose patients. A normal ABR may indicate good neurologic/cognitive outcome.

The main advantage of the ABR is that it is a non-invasive technique and that it is unaffected by sedatives. It is less time consuming and can be obtained at near threshold levels at frequencies above 2 KHz, but not in the low frequency domain.

The ABR has much of clinical utility in the area of neuro-otological disorders. However as with all other audiological procedures, it identifies the site and not the type of lesion. It merely indicates an abnormality in the system.

**Clinical applications of auditory myogenic response:**

- As a method of auditory acuity the auditory myogenic response does not provide a reliable indication of hearing status when compared to the other ERA methods available in case of cooperative subjects.

- A.M.Rs use is limited to providing an approximate determination of hearing level in young alert children or neonates.
- A.M.R, however, is simple to apply, and does not inconvenience the subjects much. It is useful as a part of clinical battery used in diagnosing a case.
- It may be used for screening purpose. AMR has the disadvantage of having poor reliability and the occurrence of false results.

#### **Clinical applications of CERA:**

CERA can be used not only to estimate hearing acuity, but also directly compare the results with that of conventional pure tone audiometry. As a neuro-otological tool, it is not of much use.

#### **Clinical application of ECoChG:**

The ECoChG provides a completely reliable measure of the individuals hearing sensitivity. Difficult to test individuals may be tested by ECoChG if conventional testing is impractical. It is often required for very hyperactive and uncooperative children, multiple-handicapped cases, and/or children with athetosis etc. It can be used in autistic children to confirm if the child has an associated hearing loss.

EcochG is an extremely sensitive indicator of cochlear and auditory nerve integrity.

The ECoChG aids not only in neuro-otological diagnosis, but also in differential diagnosis and this is achieved by a combined use of the CM and the AP.

ECoChG has many advantages over some of the other ERA measurements. At the same time, it also has its own limitations in that it provides information only in the high frequency regions, it is an invasive technique; (the trans-tympanic approach), and just as with other measurements, it cannot be used in isolation, but in combination with the others.

#### Clinical applications of FFR:

FFR because of its low frequency responsivity can provide us with information on the frequency range where ECoChG and BSERA have limitations.

In addition to the physiological assessment of auditory sensation especially in the low frequency, the FFR may also provide information about the integrity of the brainstem for synchronous firing to low frequency stimuli. This could be important to understanding children's disorders of learning that may have auditory perceptual bases.

**Clinical applications of MLR:**

- The MLR is an excellent frequency specific tool for measuring hearing sensitivity.
- The MLR helps in the identification of functional hearing loss because of its stability, sensitivity and frequency specificity (Musiek et al. 1984).
- In the field of neuro-otology, MLR may contribute in the diagnosis of acoustic neuroma and cerebral lesions.
- MLR may be of some predictive value as to the size of the tumor.
- It is suggested that the combined use of MLR with other evoked potentials such as the A3R, ECoChG and late cortical potentials would allow analysis of various parts of the auditory system with minimal time involvement.

**Clinical applications of 40 Hz evoked potential:**

ABR does not provide information regarding hearing sensitivity in the low frequencies. The 40 Hz evoked potential is a low frequency technique which has been found to be a good indicator of auditory sensitivity in the low frequencies.

Since the 40 Hz response is larger at lower tonal frequencies, it may be complimentary to the ABR which is more easily recorded in the higher tonal frequencies.

APPARATUS FOR ERA

(A) GENERAL APPARATUS

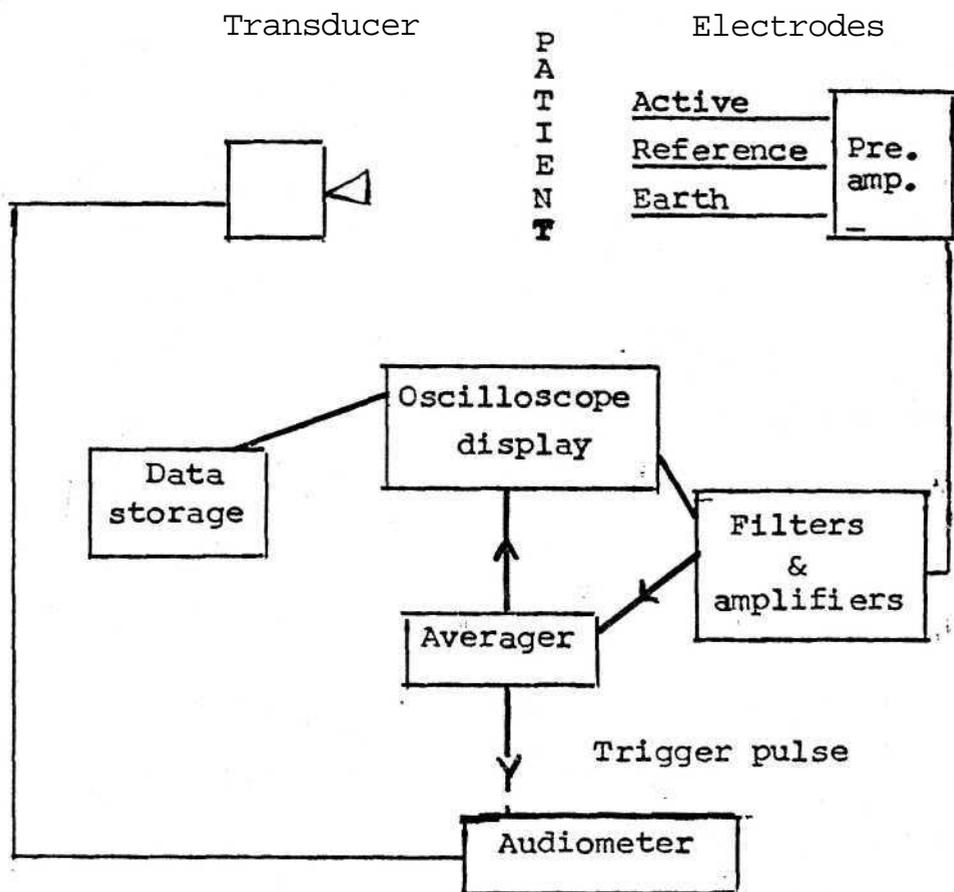

Fig. BLOCK DIAGRAM OF ERA APPARATUS

**The apparatus for ERA:**

The apparatus needed for electric response audiometry is complex and expensive. Unless one is familiar with electronics, the apparatus seems as daunting at first sight as the controls of Concorde. The clinician need not know the details of the circuits involved but should know the function of each part so that if problems develop during a recording session, he can make arrangements to overcome them. Once the basic principle of each part is understood and one knows how the parts function together, the whole apparatus seems amazingly simple and one soon learns to operate the machine with panache.

Basically, the equipment consists of one part which records the responses (electrodes, amplifiers, filters, averager, display and permanent recording device) and a separate part which provides the necessary sounds to evoke the response (an audiometer which feeds the sounds to a transducer - eg. loudspeaker, earphone or bone conductor).

The stimulating apparatus - The apparatus which generates the acoustic stimulus may be a separate instrument or it may be built into the averaging computer. If the former, the timing of the onset of the stimulus must be accurately linked to the averager so that each stimulus occurs at a definite time during each analysis period.

The stimulus - generating unit produces, at first an electrical waveform, which gets amplified, modified and finally transduced into the acoustic waveform. The accuracy with which the electroacoustic transduction takes place depends upon the quality of the transducer.

Depending upon which response ie the fast response, the middle response etc, we are interested in the acoustic stimulus has to satisfy certain requirements. The number of stimuli required and the rate of presentation are determined by the rate of triggering and each presentation has to be accurately synchronized with the sweeps of the averager to facilitate averaging.

The stimulus - The stimulus is of paramount importance for if the input is uncertain no interpretation of the output (evoked response) can be made. An ideal stimulus must meet three criteria.

- a) It must be exact in timing so that the latency of the response is clear.
- b) It must be frequency specific
- c) Its intensity must be known.

The different types of stimuli that are used include -

- (i) **Click stimuli** - The responses with short onset latencies, such as the action potential (AP/ECochG), brainstem responses (BER), myogenic responses and even the middle latency responses are best evoked by clicks. Clicks are produced by sending brief rectangular electrical pulses through a transducer. The duration of clicks may vary but is seldom less than 40/ $\mu$ s or greater than 500 / $\mu$ s.

The fast onset of the click stimulates the whole basal portion of the cochlea almost instantaneously and results in close synchronization of firing of the individual nerve fibers in this area thereby producing a large, clear evoked response.

A click stimulus is not frequency specific as it stimulates the whole of the cochlea. Virtually all acoustic clicks used for ERA have a maximum energy lying between 2-3 KHz. It is possible to present masking noise simultaneously with the click stimulus. Masking is, however, a noisy procedure and it can make threshold estimations difficult. Click stimuli is used in obtaining ECochG, BSER, Myogenic responses and MLR.

- (ii) **Tonal stimuli**:- These are frequency - specific stimuli (pure tones) having a gradual rise and fall time to avoid

scattering the acoustic energy. However, the rise time of the stimulus should not be as great as 20 msec, as is seen in pure tone audiometers. This is because the slow rise time would result in a loss of synchrony as individual nerve fibers would fire at different moments during the rise time of the stimulus and this would lead to blurring of the averaged response.

These stimuli can be used to evoke the slow responses such as the cortical responses (CERA and CNV).

- (iii) **Filtered clicks** - They are stimuli that are obtained by passing the clicks through high and low pass filters to eliminate all frequencies except those within a limited bandwidth. These have a fast rise time and cannot be produced at frequencies below 2 KHz.
- (iv) **Tone pips** - In this, a single sinusoidal wave which starts and stops at zero crossings is passed through high pass and low pass filters and the resulting wave form is used as stimulus.
- (v) **Tone bursts** - Tone bursts have a duration which is dependent on the frequency of the stimulus. It has very fast rise and fall time.
- (vi) **Masking noise** - A masking noise is a sound containing a range of frequencies (either a wide range or a narrow

range centered on some particular frequency) and may be used to prevent the hearing of a sound or part of a sound.

Masking is generally employed to prevent participation of the non-test ear while assessing the test ear. In ECoChG no masking of the opposite ear is required, but for all later responses masking is essential. This is especially true when bone-conduction thresholds are sought. Generally, it is best to use narrow band masking centred on the frequency of the stimulus.

Masking may also be used to obtain frequency specific information.

**The amplifier** - This is needed for the amplification of the electrical waveform of the stimulus.

**The attenuator** - Clinically it is essential to be able to present the stimulus at varying intensities. This is usually achieved by attenuating the input and the output of the power amplifier. It is often arranged in 5 dB steps.

**Calibration:-** Accurate calibration of the intensity of the stimulus that actually reaches the tympanic membrane is essential if precise work is to be performed. The industry recommends calibrating test equipment atleast once a year.

As the Owner of equipment, it is important to know what constitutes a good calibration. Ask the company doing the calibrating for a list of what tests and checks they do. The calibration may be achieved either by using a sound pressure level meter (SPL), using biological standard (RL) or by comparing the acoustic waveform of the stimulus with a known calibrated signal on an oscilloscope (Peak equivalent SPL).

### **The recording apparatus -**

The recording apparatus consists of the electrodes, amplifiers, filters, averager and display, together with a device for permanent recording. -

### **The Electrodes -**

The form of the electrode varies according to the position where it has to be placed on the subject. The electrodes used for ERA may be either 'surface' or 'specialised'. Most commonly monopolar recordings are taken. An active electrode (usually tagged red) is placed at a neutral point such as the ear lobe in trans-tympanic ECochG. The earth electrode (usually tagged green) is placed at a further neutral point (commonly the forehead).

Monopolar or common reference recordings compare the output of the active and earth electrode with that of the

reference electrode. Monopolar recordings are preferred over bipolar recordings for recording the evoked potentials as the former are less liable to produce distortions than the latter.

Surface electrodes - Surface electrodes are those that are placed on the skin. The most commonly used electrodes are the standard silver/silver chloride EEG disc variety.

Specialised electrodes - Some responses, such as electro-cochleography require a special electrode that may be placed in a particular anatomical position (either through the tympanic membrane or on it). The transtympanic electrode is usually a thin needle insulated except at its very tip. The tympanic electrode is usually a silver ball electrode which may be coated with silver chloride.

#### **The pre-amplifier:**

This is usually placed close to the electrodes so that the signal may be amplified before it is sent down cables to reach the main bulk of the recording equipment. The evoked response being minute, the signal needs to be amplified to prevent it from being swamped by interference. This amplified signal is large compared with any incidental electrical activity picked up later. Two other important features of the pre-amplifier are (a) common mode rejection (CMR) and (b) input impedance.

CMR is the rejection of any signal which is the same or common to both the active and the reference electrode. For eg. both the electrodes pick-up mains interference to almost the same extent, and by rejecting the common signal the problem is virtually overcome. Common mode rejection ratio (CMRR) : The CMRR is a measure of how well a signal, common to both active recording leads of the physiological amplifier, is attenuated. Practically speaking this common signal is usually 60 Hz interference (A typical CMRR would range from 80 dB to 120 dB).

Input impedance is the amount of electricity which may flow into the system.

In practice, it is best to have an input impedance which is always higher than the electrode resistance, as this effectively prevents entry of extraneous electrical interference.

#### **The Main amplifier -**

cii The final amplification or gain is usually achieved by an amplifier sited on the main bulk of the recording apparatus. The amount of amplification/used must be known accurately. This can be achieved by feeding a signal of known sizes into the pre-amplifier.

Some ERA equipments have facility for automatic gain control and provisions for a calibrating signal to be averaged simultaneously with every ERA response obtained.

### **Filters -**

Each response in ERA has a particular range of frequencies within which the energy lies. By knowing the range, one can exclude all the other frequencies which are not adding to the response but form only a source of artefactual contamination. For instance, the energy of the slow cortical response lie chiefly in the range of 4-6 Hz. It may then be suitable to place a high pass filter (below which frequency nothing passes) at 1.6 Hz and a low pass filter (above which frequency nothing passes) at 13 Hz.

The unaveraged signal -

It is advantageous to incorporate a facility for examining the unaveraged signal both before and during the test procedure. This will enable us to recognise the pattern of mi acceptable signal and to detect problems that may ruin the recordings.

### **Artefact rejection -**

One of the most frustating sights during ERA procedure is to watch an averaged response slowly building only to be

suddenly swaped by an artefact. Artefacts may be serious because there is tendency to accept it as true evoked responses resulting in a misdiagnosis. This makes it essential to have a method of recognising and rejecting the artefacts. These are two methods used for artefact rejection.

1. Off line method - Here the recording is processed after the recording session. It is not very practicable clinically as they involve time.
2. On line methods - More practicable than the off line method. There are manual and automatic systems. In manual systems, a switch can be moved whenever an artefact is recognized on the on-going trace.

Automatic systems of artefact recognition and rejection are of great value, especially in these tests in which an attempt is being made to average a response from a young active subject.

#### **Display -**

It is important to be able to examine the results of averaging at the time of testing and before a permanent record is taken. Most apparatus displays this information on as oscilloscope. It is also possible to see each response building during averaging. One can detect sudden baseline fluctuations which occur when largetransient artefacts contaminate the response. Most apparatus includes a facility so that measurements of the latency and amplitude of the evoked response can be taken directly from the display.

## **Data storage -**

### **Permanent recording facilities:**

It is obvious requirement that the data obtained during ERA procedures should be stored for later analysis. This storage may be achieved either by using the memory of a computer, tape or simply by making permanent copies of the recording. Permanent records of the averager display may be of 2 types: pen recordings and photographic prints.

Storage of raw data - The electrical activity recorded from the patient may be recorded on to a magnetic tape or 'floppy - disc'. This data can then be fed into the averager at a later date. The advantage of storing the raw data, is that manipulations can be accomplished at a later date without causing inconvenience to the patient.

Pen recordings - Provided by 'X-Y' plotters. Helps obtain a clear permanent trace which may be easily changed in amplitude. Recording done on a graph paper which simplifies any analysis. The disadvantage of pen recordings is the frequent need for calibration.

Photographic method - Involves photographing the response as it is displayed on an oscilloscope.

Storage of data must be arranged in such a way that previous work may be readily retrieved. It is necessary to label the data providing information about patient's name, age, hospital number, date of testing, ear being tested etc. The data should be stored in a manner which permits quick retrieval. It is advantageous to keep a separate record of the findings in book form for safety as well as a means of quickly checking cases.

**Special requirements for recording of different evoked potentials**

Besides the basic apparatus common for all types of ERA measurements, certain factors need to be considered which are specific to the type of evoked potential testing.

**Auditory myogenic response -**

Recording equipment - Standard EEC silver cup electrodes are used as active and earth electrodes. In using the crossed acoustic method, it is important that we use low noise biological amplifiers having a high input impedance and a high common mode rejection ratio. The main amplifier forms part of the average while a small pre-amplifier can be attached with a harness to the back of the child, thereby permitting more freedom to move. Narrow band filters can be used to eliminate background noise.

For threshold determination a single channel average will be adequate. A two channel average is essential if neurological work is to be performed. The latter provides a control against an artefact being mistaken for a true response. However this is more expensive.

**Requirements for stimulus generation -**

- A brief stimulus with rapid rise time is ideal. Hence clicks or pure tone bursts of 8-2 KHz can be used. For clinical purposes, stimulus repetition rate of 10/8 may be used.

A high quality transducer is a must to maintain acoustic waveform of the click. An electrostatic loudspeaker is preferred for testing children.

### **Special requirements for CNV audiometry -**

Standard silver/silver chloride EEG dome-shaped non-polarising electrodes may be used. Amplifiers should satisfy low noise biological specifications. Bandpass filters can be used to eliminate some of the unwanted electrical noise.

An averager is needed to visualise the response clearly. For stimulus generation, CNV requires two separate stimuli - the conditioning stimulus (which may be a click, pure tone burst or words) and the imperative stimulus (0.5 sec duration flash of light) and each must receive a triggering Pulse.

### **Requirements for ECochG testing -**

An important consideration here is the type of electrode used. This varies with the method used for recording the ECochG.

In extratympanic method, a wire electrode or a hypodermic syringe needle is used to insert a silver wire into the meatal lining in the postero-inferior rim of the meatus.

In the transtympanic method, wire electrode, is used, approximately 0.3 mm diameter, insulated throughout except for the tip and the other end at which point it is connected to the electrode holder. The electrode is pierced through the tympanic membrane and the tip of the electrode comes in contact with the promontory.

Low biological amplifiers are essential. Filter settings used vary from 2-10 Hz to 3-5 Hz (Gibson, 1978).

An averaging system with a split memory will be of advantage to the tester.

A monitor oscilloscope, artefact rejection facilities and facilities for permanent recording are also needed.

#### **Stimulus generation -**

Very brief stimuli with sharp onset is recommended. Tone bursts are found effective in eliciting the A.P. Preferable to use earphone for delivering the stimuli. Loudspeaker may be provided if chamber is anechoic.

Masking facilities are not essential for clinical purposes, but may be useful for research purpose.

#### **Requirements for ABR testing -**

Just as with other ERA measurements, high quality EEG electrodes, low biological amplifiers, filters, an averager

a monitor oscilloscope, artefact rejection facilities and facilities for recording the results are required.

### **Stimulus requirements -**

Very brief stimulus with sharp onset characteristics such as clicks, filtered clicks and tone bursts may be used, to obtain satisfactory results. While obtaining BER care must be taken over the choice of stimulus transducer. It is necessary to shield the transducer with mu-metal to reduce magnetic field which can produce artefacts. If loudspeaker is used, anechoic test chamber is essential. Magnetically shielded headphones do give good results. The apparatus must include provision for the application of masking noise to the non-test ear if monaural information is sought.

### **Requirements for measurement of FFR -**

- As in ECoChG and BSER, a high gain and high frequency response pre-amplifier is necessary. However, a lower frequency limit has to be set on the pre-amplifier to allow for passage of the low-frequency synchronous discharges.

### **Requirements for MLR -**

The electrodes used are similar to that used in CERA ie silver chloride dome shaped electrodes. Besides low

biological amplifiers, averager and an oscilloscope and FM tape recorder would be useful to obtain recordings of the responses for later analysis. The averaged response can be permanently traced on the paper or photographed.

#### **Stimulus specifications -**

Optimum stimulus is a click with sharp rise time. Tone bursts may be used. A good quality transducer is needed to transmit an acoustic waveform free of click artefacts. Ear-phones are used with adults and sleeping children.

#### **Test requirements for 40 Hz evoked potential**

Standard EEG silver cup electrodes may be used. A clinical averager which is externally triggered by the stimulus pulse generator maybe used, or one may opt for fourier analysis.

Fourier analysis is economical in terms of time and money and provides objective measures of amplitude and phase. Low biological amplifiers and monitoring oscilloscope are also needed.

#### **Stimulus specification -**

Pulse generator which is set to trigger tone bursts at a rate of 40/s is needed. Good quality transducers are needed to deliver the stimuli without introducing any distortion and/or artefacts.

## THE TEST ENVIRONMENT AND INSTALLATION PROCEDURES OF E.R.A

### INSTRUMENT

#### (A) GENERAL PROCEDURES -

##### The Test environment:

There are several important factors to be considered when deciding which position within a hospital or similar building to site the apparatus. The first consideration would be to place the equipment in a convenient room which is readily accessible to those who use it.

If the work is to be clinical, it is of advantage to place the apparatus close to the place where the patients are seen.

If children are to be anaesthetised, it is best to have the equipment near the operating theatres and wards so that it is convenient for the anaesthetist to do his job.

It is unwise even to contemplate transporting the equipment temporarily into actual operating theatres unless one is prepared to spend a lot of energy and time.

Frequent movement of the delicate apparatus will probably result in malfunction and cause knobs to break off and dents to appear,

Operating theatres are noisy and contain large pieces of apparatus which produce gross electrical interference, making it difficult to identify any responses (Gibson and Ruben, 1978).

Now-a-days, portable ERA instruments have been developed which may be considered in set-ups which require frequent carrying of the equipment from one department to the other

Hospitals are full of apparatus which produce electrical or other types of interference. Once the ERA apparatus has been installed, it is usually necessary to engage in several hours of detective work tracking each source of interference. Transformers emit interference based on 50 Hz (AC mains frequency) and higher harmonics of that frequency. Fluorescent lights within about 15 feet of the electrodes must be disconnected. In some rooms, a ring main may interfere with the apparatus and it may be necessary to place an isolating switch outside the test chamber, so that all the mains circuits within that area can be turned off. Generally, the removal of interference from these sources is all that is required. Occasionally there however may arise the need to suppress some other machinery placed near the vicinity of the E.R.A. apparatus (Gibson and Ruben (1978)).

Sometimes, external interference is impossible to control for example testing in more adverse environments like an operating room or an intensive care unit, and thereby poses severe limitations due to environmental sound levels and electrical interferences and must be dealt with.

Power line interference is a problem especially for ABR and MLR recordings, special filters (notch filters) may be used in such situations which suppress this type of interference but can severely distort the response waveform (Jacobson, Hyde, 1985).

In ERA testing, stimulus repetition rate is an important variable and it is necessary to ensure that the stimulus repetition rate is not an exact integer submultiple of 60 per sec, so that the interference is not locked in time to the averaging process.

Thus by means of special timing of the stimulus repetitions it is possible to partially cancel the interference. Another important variable is stimulus polarity and one can cancel the stimulus artefacts by alternating the polarity of the stimulus (Jacobson, Hyde, 1985).

### **Testing environment:**

A sound treated room with electrical shielding and provision for visual and auditory monitoring is an ideal testing environment (Katz, 1979). Sound treatment should be done for walls, floors and ceilings by utilising acoustic tiles and carpets..

The American Standards Association (1961) and ISO (1964) have specified the maximum ambient noise levels that can be tolerated in a sound treated room. These specifications may be taken into consideration during construction of a room for ERA measurement.

| Frequency setting(Hz) | Octave band | ISO(1964)<br>SPL in dB | ASA(1961)<br>SPL in dB |
|-----------------------|-------------|------------------------|------------------------|
| 125                   | 75-150      | 31                     | 40                     |
| 250                   | 150-300     | 25                     | 40                     |
| 500                   | 300-600     | 26                     | 40                     |
| 1000                  | 600-1200    | 30                     | 40                     |
| 2000                  | 1200-2400   | 38                     | 47                     |
| 4000                  | 2400-4800   | 51                     | 57                     |
| 6000                  | 4800-9600   | 51                     | 62                     |
| 8000                  | 9600-19200  | 56                     | 67                     |

Besides the above requirements the sound treated room should be sufficiently spacious with good ventilation and diffused lighting for the comfort of the patient. These measures will ensure good cooperation from the patient which is essential for valid hearing measurements (Murthy, Jacob, 1970)).

There are different methods of constructing sound treated rooms. The following factors need to be considered. Orientation - generally a sound treated room will be constructed in an ordinary room of a building. This particular

room should be selected in such a way that it is away from heavy traffic or any other noise source in the vicinity (Murthy and Jacob, 1970).

Size - The rooms should have entrances wide enough to accept entry to wheel chairs and occasional stretchers (Hallen and Sheldon, 1976). It is preferable to have a room of the size of 10'x8'x8' for conducting all the tests. The dimensions may be changed in terms of the user's requirements. In addition to the sound treated room a control room of proper dimensions would be ideal.

Walls - In a moderate ambient level a single brick wall with two sides cement mortar plaster is adequate. Total thickness of the wall may be 9 or 10 inches. In case of excessive ambient noise level, it is advisable to have double walls of single brick in length-wise construction separated by an air-gap of 3-4". The air gap between the two walls should go deep into the floor at least by 12 inches which provides considerable isolation by the inner floor from outer one.

Interior walls can be fixed with soft materials such as acoustic tiles to help absorb sound and limit vibrations. Fiber glass may be used for better acoustic treatment (D'Mello and Samuel, 1982).

Ceiling - The ceiling of a sound treated room must be of higher density materials such as reinforced cement concrete. For double wall construction, the outer wall should carry the concrete slab and the inner walls should support the false ceiling. The space between the concrete roof and false ceiling may be filled with sound absorbing materials. It is advisable to have a false ceiling with a sound absorbing material in the control room to reduce reverberation.

Floors - Floors may be covered with coir matting and carpets.

Doors - It is preferable to have double doors fixed in such a way that one opens into the room and the other opens outwards. Each door may be made up of teakwood frame covered with teakwood planks bearing an air gap between the planks. The air gap may be filled with sound absorbing materials such as glasswool or fine river sand. A thick rubber lining along the edges of the doors will be an added advantage to avoid leaking of sound waves. The doors connecting the rooms must be solid and tight enough to ensure acoustic seal.

Ventilation - Indirect lighting may be provided by suitable means to make it pleasant. Adequate ventilation and circulation of air should be provided. Air conditioning could be made by suitable ducting system. It is essential that the AC plant should be installed away from the sound treated room

and the directing should be designed properly to keep the noise level to a minimum. An alternative is to have a suitable room air cooler in the control room. This may be operated as frequently as desirable keeping the door between control and test rooms open.

If the place is very cold, moisture absorbing material must be placed between the glass to keep the observation windows from getting fogged.

Averaged electroencephalic audiometry is most efficient when the voltages of electrical artifacts generated by the patients nervous system or by other sources are relatively low (Sheperd et al. 1970). Physiological noise sources often tend to be more problematic than nonphysiological noise sources which can be controlled in several ways, including electrical shielding of the testing enclosure, headphone, cables and electrodes and powerlines. Reduction of the physiological noises can be obtained by careful application and positioning of electrodes and manipulations of patient state such as sleep, sedation or general anesthesia, primarily to reduce muscle activity (Jacobson, Hyde, 1985).

A source of electrical noise that is not generated by the patient's nervous system is the electrostatic charge over the insulation of standard BEG electrode wires that are

commonly used to connect the scalp electrodes to the electrode box. Movement of the insulating coating of standard EEG wires evokes a considerable change of electrical potential and thus introduces high voltage noise into the wires. Sheperd, Wever, McCarren (1970) constructed a cable by encapsulating standard scalp-electrode wires and a ground lead within a single length of Tygon tubing which is filled with a graphite glycerine paste. This graphite glycerine cable was found effective only against electrical artifacts generated by movement of standard electrode wires but ineffective, against artifacts generated by patients nervous system.

In low level stimulus applications, one of ten encounters interferences at the power line frequency. These interference problems are almost always due to inadequate or improper grounding circuitry and techniques and less frequently, they are due to electromagnetic radiation into the environment of the stimulus and monitoring systems.

Power line interference can arise from nonequipotential power ground circuits. It is generally easy to find situations where potential differences of several to tens of millivolts exist between one ground point and another. These potentials differences are created by ground currents in ground circuits with poor connections, inadequate wire diameters.

high contact resistances and also by circulating currents in building structure. The minimization of these interference problems requires exceptional care in wiring and system design.

The first order solution is to provide a single, well-defined power system ground point and to minimize the opportunity for the existence of alternate ground points. If the ground wires are of adequate size and of sufficient short length and make secure electrical contact, an equipotential ground environment can be closely achieved. Careful attention to good equipment grounding, elimination of redundant ground wires, and proper circuit wiring also is essential.

Noise can also be introduced via inductive pick-up or electrostatic coupling. Much can be achieved to minimize these noise pickups also by proper wiring and shielding of both signal carrying leads and the devices themselves (Pfeiffer, 1974).

Pfeiffer (1974) has given a brief outline of the few procedures that can help to reduce low-level interference are as follows:

1. Identify a signal and substantial signal ground -reference point in order to establish an equipotential ground.

2. Keep signal cables as short as possible in order to minimize capacitative pickup, and in some cases, to assist in maintaining an equipotential ground environment.
3. Do not use the cable shield as a signal conductor; this will minimize interference and improve shielding.
4. Do not splice cables, this will minimize signal drop in the leads, and minimize noise pickup by stray currents in leads.
5. Untwisted lengths of wire at the site of termination should have a minimum exposed area in order to minimize inductive pickup.
6. Use adjacent pins of cable connectors for the signal leads to minimize crosstalk from other signals.
7. Shields, when carried through cable connectors, should be through pins adjacent to the signal pins, so that maximal shielding effect can be obtained within the connector.
8. Make sure that the signal cable shield is grounded at only one point - preferably at the low side of the signal source, in order to eliminate any current flow in the shield and to prohibit a ground loop.
9. Any unused leads in a cable should be grounded to the shield at the opposite of the end where the shield is grounded in order to help eliminate noise pick-up.
10. For low-level signals, use lapped-foil shields with a low resistance drain wire wrapped around a tightly twisted signal pair; this will provide better shielding.

No matter what the procedure, some of the elementary records may still contain intermittent high amplitude or rhythmic activity which can seriously compromise the effectiveness of summing or averaging. For example, during a slow cortical AEP averaging run gross. Movement of the patient can produce electrical artifacts as large as 100  $\mu$ V or more; after averaging of, say, 20 records, this single artefact will still have a size of 5  $\mu$ V equal to that of the typical AEP itself. Such an artefact might easily be mistaken for a response, or even cancel out a genuine response.

This problem of occasional large potential artefacts is much improved by the incorporation of automatic artifact rejection systems into commercial 'averagers'. These systems detect the presence of relatively large voltages and discard the contaminated elementary records. Although the time required to obtain the desired number of averaged records may increase, the reliability obtained is far better. Inevitably, the final averaged record will still contain residual noise which can compromise response detection and measurement. It is therefore advisable to replicate any average AEP and to regard only reproducible waveforms as genuine.

## **(B) SPECIAL PROCEDURES FOR RECORDING DIFFERENT EVOKED POTENTIALS**

### **(i) Test environment for auditory myogenic responses:**

The acoustical environment for auditory myogenic response testing need not be sound proof but should be quiet, as this

test is not wholly accurate but only gives an indication of the hearing acuity to within 30 dB (Gibson and Ruben, 1978).

Adults can be tested under earphones and one can test each ear separately by employing masking noise. For very young children and children who refuse to wear headphones, a free field loudspeaker can be used for stimulating both ears by placing it close to the child's head. As clear responses are not obtained from relaxed subjects, there may arise a need to have subject seated on a fairly uncomfortable chair without any head support. This is required to maintain active muscle tone.

(ii) **Test environment for ECoChG:**

Environmental considerations are very important for successful ECcchG measure. The AP evoked response is -very susceptible to ambient acoustic noise (Teas et al. 1962) and a sound treated room is essential if reliable measures are to be obtained for signal levels corresponding to normal hearing thresholds.

An anechoic chamber would be the ideal for ECoChG testing, but this is usually impractical. If the ECoChG procedure needs to be carried out in an operating room or other non-treated areas, careful noise surveys should be conducted

prior to testing. Ambient background noise should be maintained at a constant level during the ECoChG recording. Failure to do this could result in an elevation of the apparent threshold of the response, distortion of the response wave form, or modification of the response growth pattern with changes in signal Intensity (Glattker, 1978).

Subjects are best tested lying relaxed on a couch. The test room should be large enough to accommodate the couch and an operating microscope for accurate placement of the electrode. Frequently there arises a need to accommodate the patient, tester, anaesthetist, anaesthetic equipment, instruments and assistants. In such circumstances, a small enclosed space would be very trying.

An IAC (Industrial acoustic company) booth made with a perforated steel lining and earthed with a thick copper earthwire could be used. All mains electric supplies can be carried in copper conducts and can be turned off by means of an external isolator switch should electrical interference be a problem.

In set-ups where suitable enclosure is not available for ECoChG, it may be necessary to employ a closed acoustic system instead. For this, a TDH-39 headphone is enclosed in mu-metal in a special capsule to prevent electromagnetic

radiation to the electrode. It is attached by means of a magnetic ring to a special magnetized circumaural retaining ring. Care must be taken to ensure that the top of the electrode holder sits below the level of the circumaural ring so that it is not pressed on by the encapsulated headphone. A freefield method is preferable if a suitable test room is available (Beagley, 1981).

**(iii) Testing procedures for 40 Hz evoked potentials:**

The subjects must lie down comfortably in a sound treated room. If seated, the neck should be supported so as to avoid any movement causing artefacts.

The subjects are to remain awake during testing. The sound stimuli are presented through earphones.

**(iv) Test environment for ABR, MLR and CERA** are similar in the sense that subjects need to be tested in a relaxed position to prevent interference of myogenic activity.

Older cooperative children and adults can be made to relax on a couch with a pillow placed under the neck to allow the neck muscles to relax. Active children or very young children need to be sedated after obtaining medical clearance and supervision for sedation. The room should ideally be sound treated.

## CONSIDERATION FOR PROCUREMENT OF ERA SYSTEM

The task of buying an ERA equipment or for that matter any speech and hearing equipment often evokes apprehension and sometimes anxiety in prospective purchasers. In most cases, the buyer has to live with the instruments chosen for many years, and no one wants to be responsible for a poor choice, but in a new set-up the buyer has to make purchase decision taking into consideration a number of factors.

A good purchase is a result of planning and multidimensional business decision.

The four critical elements that should be included in purchase decision making are -

- 1) Technology - This defines the testing capabilities, applications and life expectancy of the equipment.
- 2) Capital budgeting - Equipment purchases are an investment and the economic consequences of investing in the equipment must be closely evaluated.
- 3) Competitive advantage - Equipment purchase can provide the hearing health professionals with significant competitive advantage.

Equipment can reinforce or help build a professional or high/tech image. A client gets impressed by the use of computers and computer based test equipment, video monitor that displays

test results and computer print outs of test measurement allow the client to become more involved in their own health care and facilitate customer education.

- 4) Resource requirement - The acquisition of new equipment often has unexpected costs, time, fund, change. These costs may be associated with the installation or actual use of the equipment. One should plan for these costs.

Since the advent of the first evoked potential system, more and more commercial response averagers are being introduced in the market and the clinician has a wide array of instruments from which to choose.

In the past some clinics were working on their own tailored systems which although fully satisfied the user in most cases, tended to be expensive as compared to commercial systems if one included the hours involved in Engineering it (Madsen and Hansen, 1972).

Some of the basic questions which need to be considered before procuring an ERA system are -

- "What will be the present and future applications"?

The answer to this question will vary a lot from one clinic to the other, but it may be useful to extend the question in to the following detailed area.

- a) To the ERA equipment mainly for clinical or research purpose?

In case of the former the clinician would be satisfied with facilities available for diagnosis and differential diagnosis of various otologic/neurologic disorders. On the other hand if research applications are to be taken in mind, it would be of help to have many other options or menus which may not be essential in routine testing. For eg. In certain clinical settings mass data storage of the information may not be essential, however, it would be a pre-requisite for research purpose.

- b) Who will be operating the ERA system? The clinician, an Engineer, Nurse, Technician etc.

In this case, one may have to opt for an equipment which is easy to handle especially if it is to be operated by technicians or nurses. Also facility for data storage or print out for analysis of data at a later stage by the concerned specialist may be needed.

- c) Where is the system to be installed?

In a shielded or non-shielded room; with or without a silent cabin installation; together with other audiological instruments or alone; in noisy or quite environment etc? For eg. In case of noisy environment, an ERA with a high common mode rejection ratio would be preferable.

d) How is the engineering capacity?

In certain set-ups who do not have an engineering section to deal with repairs or calibration problem, the necessity of help from local agents or service engineers is a must. Most of the ERA equipments are purchased from foreign countries and it is not feasible to ship it to the manufacturers during times of crisis, hence in case there is no engineering unit to take care of the problem, it is wise to choose only those equipments who have the distributors or service engineers located nearby. Also it is essential that the spare parts of the equipment be easily obtained in case of damage.

In such cases one may need to enter into a service contracts for smooth maintenance of the equipment. Some of the aspects of a service contract could include are travel or shipping costs, service costs (parts and labor) preventive maintenance, annual certification and emergency service.

Many organizations such as schools or clinics, prefer to purchase service contracts because they can put the cost into the budget and not be faced with an unexpected expense.

Because of the care equipment receives under a service contract, longer product life can be expected. However, most of today's ERA equipment are of high quality and do not breakdown often enough to justify the contract cost.

e) How many investigations have to be performed each day?

In this case attention needs to be given for the display section.

Most systems are able to display either the ongoing activity or the averaged results during the averaging procedure and some systems can display both simultaneously. It is important to be able to watch both the input and the results throughout the averaging simultaneously.

Some systems offer the feature of a display and print out section with its own memories, totally separated from the averager memory. This feature saves a lot of time in the daily use of the system, and would therefore be an asset in case of heavy patient load in the particular set-up.

f) What are the financial resources?

It is certainly a heavy investment to procure an ERA system. The cost of the ERA equipment is about 10 to 20 times as much as a good clinical audiometer. The individual who wishes to buy the ERA equipment may therefore require to justify the need to purchase it especially in a government set-up or private or semi private organizations.

Making a prior list of the facilities that are needed will aid the individual in arriving at an appropriate decision on the purchase of the equipment.

Only if one is completely satisfied with his/her buy will he/she be in a position to guide others as well in their choice of equipment.

This satisfaction stems from many things.

- (1) The equipment must perform to specifications in a reliable and dependable manner.
- (2) Its capabilities should allow the user to perform all types of tests which the particular facility wants to offer.
- (3) The equipment should fit the physical constraints of a facility.
- (4) The instrument should be easy to master
- (5) Adequate inservice should be available during the learning period.
- (6) The instrument users must feel comfortable with the equipment and must have absolute confidence in the results.

The following are the steps/procedures to go through for arriving at a decision regarding buying the equipment.

- Obtain address of the place where the equipment could be purchased from. Write to them and collect pamphlets, catalogues from different manufacturers.

It is a daunting task to compare more than 20 different models produced by more than 15 manufacturers all over the world. Chart indicates the list of different ERAs manufactured and their product capabilities.

It is wise not to risk buying an equipment from manufacturers, who are newcomers in the field, as one never knows if they will survive. Select well-established companies and priority may be given to those from whom some other equipment is already purchased and is working to one's satisfaction.

It is often advantageous to try to define the long-term goals of the facility. If expansions of a facilities service is a serious possibility, equipment to be purchased should have broad enough capabilities to meet future needs and to be able to Interface effectively with any future purchases. A close examination of a facility will help identify its strengths and weaknesses and enable planning for future growth. It is important to define needs, goals, patient population, physical plan and staff capabilities beforehand, to avoid costly mistakes that can result from hasty decisions.

- Go through the technical specifications of each of the models available. This would help the clinician to make a list of categories which one would want to include in the ERA instrument and ignore the others which are felt unnecessary.

For eg. Cognitive response stimulus unit, somato-sensory stimulus unit, visual stimulus unit may not at all be essential if one's aim in the purchase of the equipment is only for the threshold estimation of hearing.

Some of the technical factors/specifications which need to be considered are:-

**(A) Stimulus frequency specificity:**

The choice of stimulus depends primarily on the test objective and the AEP to be used. For any AEP a click stimulus might be used for obtaining average behavioural thresholds in the 1 to 4 KHz range.

In testing slow cortical responses, the problem of frequency specificity does not arise. Here long tone bursts with gradual (10 to 20 ms) rise time can be used. For carrying out MLR testing, frequency specificity using tone pips with relatively long rise time (5 ms) would probably be adequate. For the ABR and ECochG where long stimulus rise times can degrade AEP development due to loss of neural synchrony, frequency specificity is a major issue.

**(B) Another factor of importance is stimulus repetition rate.**

The repetition rate has a major effect on the number of averaging runs which can be carried out in a given test run.

In ERA, the main objective is to demonstrate AEP presence or absence, so the rate should be chosen/to make these decisions as efficiently as possible. Some equipments may provide only 2-3 options in repetition rate changes eg. 11.4/s, 22.4/s while

others may provide a wider range where one can use a stimulus repetition rate as slow as 1/s to as fast as 90/s. This facility is probably considered in research oriented set-ups where one would wish to find out the changes in latency, amplitude and waveform morphology with increasing repetition rate and aid in differentiating retrocochlear pathology from cochlear pathology.

**(C) Calibration system -**

Since one of the best way of achieving a proper and correct calibration is the subjective psychoacoustic method (Plutchik), it should be possible for the ERA equipment user to calibrate the system himself in an easy way and preferably without any use of tools.

All existing ERA systems include a circuit for calibration of the auditory system. The relatively new ERA systems include a digital calibration with a memory back-up for storage for all the calibrations of the various types of stimuli.

This calibration system offers the feature of being very easy to use by turning a key-locked calibration switch on the front panel.

**Common mode rejection (CMR) -**

The importance of CMR in ERA is that it suppresses ambient and unwanted electrophysiological noise. Ideally the CMR should not be less than 106 dB ( 2 00 000) which means that noise is suppressed with the factor 200000. If the CMR is smaller, it will require too many averagings to obtain the necessary sufficient noise free result, and especially if the system must operate in a nonelectrically shielded room.

**Number of data channels -**

One or multi channel input depends on the type of investigation to be performed. In most cases one channel will do, but a feature of two channels may be convenient for certain latency measurements. Both ipsilaterals and contralateral recordings can be obtained simultaneously with two channel instruments. Some systems offer four channels of input\*

Besides the differences in technical details, all existing ERA systems maybe divided in three main groups according to their general structure.

Group-I: Dedicated digital units with pushbutton controls and rotary switches but without any facility for connecting an external data system.

This system is usually sufficient for use of ERA in daily clinical work and some limited research work.

Group-11: Computer based systems which are purely keyboard operated via 'menus' on the monitor screen and having facility for an optional or built-in data interface to be connected to an external data system. The menus offer a lot of facilities including fully automatic programs and storage of results via internal or external memory and data systems. Such type of systems are excellent for research work but may appear rather complicated in daily clinical routine.

- Group-111: The group III systems offer all the advantages of Groups I and II systems and enable the user to firstly invest in a limited Group-1 - like system and then later extend the system with all the features of Group-11, when required.

(Cited from Madsen and Hansen (1981) 'Considerations for Procurement of an ERA systems', Scandinavian Audiology, Supplement 13, P.155-161).

Preferably obtain information about a particular piece of equipment which you wish to buy from other professionals who have worked on it and learn about their experiences regarding reliability of generated data, ease of use, service

history, availability of inservice and support from the manufacturer and/or special instrument distributor who sold it. One place to start such an inquiry is with former instructors, employers or classmates. These are often individuals who will provide a candid assessment of their experiences. However, one should not permit a single assessment to guide a purchase, an individual may have had a bad experience with a piece of equipment, that generally has a good track record. Seek out more than one opinion to avoid getting biased.

Shop around - After speaking to a variety of instrument users, it may be advisable to see the various pieces of equipment. One may get an opportunity to handle these equipments during exhibits in conferences, seminars etc. This not only gives a first hand opportunity to watch the working of the equipment, it also enables one to obtain necessary literature and technical specifications for later study.

After making a check-list and arriving at a tentative decision regarding the purchase of the equipment in consultation with other professionals, the next step would be to contact the special instrument distributor (SID). Besides the manufacturer, the role of the SID is equally important in decision making process, it therefore becomes essential

to choose a SID whose reputation and work is well known and respected. The manufacturers provide information on who distributes the specific instrument of interest.

Functions/Role of SID:

1. The SID not/only sells instruments but also installs and usually warrants the equipment for the manufacturer.
2. They tend to repairs of equipment when necessary. As most of the ERA equipments are purchased from foreign countries, it is not feasible to ship them to the manufacturers in case of repair. It is here that the SID comes to the rescue.
3. Any instrument, whether an ERA or an audiometer needs to be frequently calibrated so that it provides a faithful reproduction of the event measured without introducing any distortions.

Most of the ERA equipments available now-a-days have in-built capability of calibration for physiological amplifier, but some do not have this facility. Also some equipments permit checking and calibration using simple means, but few may require the need to open up the instrument. In such cases, SID are often called upon to calibrate the instrument on a regular basis.

4. The SIDs provide ongoing support during the time of first working with the new instrument.

5. The SID generally goes through the needs list prepared by the prospective buyer and suggests the specific piece of equipment best suited to meet the individual requirement. Eg. If the ERA equipment is to be purchased in a school for the deaf for purpose of screening the hearing impaired students, then there would be no need to buy a multi-channel evoked response audiometer with somatosensory/visual stimulus unit with facility for changing stimulus repetition rate/polarity and data storage system, rather it would suffice to have a single channel with adequate facilities for threshold estimation, on the other hand these facilities would be essential in case of research studies or in neuro-otological diagnosis.
5. Besides technical specifications the SID also keeps the customers budget in mind. If there is a fixed amount to spend, certain pieces of equipment may be outside the budget. In short, a SID and specifically, the instrumentation consultants should be able to help define refine and target the equipment needs. They should advice on financing the equipment and arrange for its installation and inservice.

**Buying a used equipment:**

When considering the purchase of used equipment, the following questions should be asked.

- Is the product still in production?
- Can you get parts for it?
- Was it manufactured by a reputable supplier?
- Is the manufacturer still around?
- Does your local SID service that product?
- How did is the equipment?

Examine the service record. Consider why this equipment was traded in? Why is it being sold?

One of the main advantages of purchasing used equipment is the cost factor. If used equipment is purchased through a local SID, there are chances of the equipment being reconditioned and depending on the condition will carry a limited warranty. If the equipment is to be purchased from a private party, it is recommended that the product be shipped to a reputable dealer/distributor for evaluation. Without an ' electronics background, thorough examination of a product to determine if it is in good condition or not is difficult. Normally, a distributor will evaluate used equipment for a nominal fee.

Even if the piece of equipment that is running smoothly is purchased, consideration should be given to who can be called when service is required.

The effective life of used equipment is less. As a buyer, determination must be made as to whether the loss of those years will be worth the savings is lost.

# Specifications for auditory evoked response instrumentation

• Indicates product has this capability.

|     | Amplifier/AND/OR Corp. Models MK1 (2 Ch.), MK5 (2 Ch.), MK6 (2 to 4 Ch.), MK 7 (4 Ch.) | Amplifier/AND/OR Corp. Model MK10 | Axonics Audit T/W Model AX-135 | Bio-logic Model Brain Atlas | Bio-logic Model System 6 7.7B/7H/7HB/7N2/7N4 | Cadwell Model 5200A | Cadwell Models 7400 (4 Ch.) and 8400 (16 Ch.) | Life-Tech Model 8101AR | Life-Tech Model 8102AR                      | Melissan Model ERA 1250 and ERA 2250       | Nicolet Model Pathfinder I/II              | Nicolet Compact Four | R.C. Electronics, Inc. CPS-AEP and APL-AEP | R.C. Electronics, Inc. Models CPS-ADR and APL-ABII | Teca Corp. Models EP-40A (4 Ch.), TD10 (1 Ch.), TD20 (2 Ch.), NeuroLab (16 Ch.) | Telodyne Avionics Model TA-1010                      | Tesor Model TM3000 | Tesor Northern TM 3500 | Tracqualica Model Tracy |
|-----|--|-----------------------------------|--------------------------------|-----------------------------|--|---------------------|---|------------------------|---|--|--|----------------------|--|--|---|--|--------------------|------------------------|-------------------------|
| 1.  |  |                                   |                                |                             |  |                     |   |                        |   |  |  |                      |  |  |   |  |                    |                        |                         |
| 2.  | 1  | 2                                 |                                |                             |  |                     |   |                        |   |  |  |                      |  |  |   |  |                    |                        |                         |
| 3.  |  |                                   |                                |                             |  |                     |   |                        |   |  |  |                      |  |  |   |  |                    |                        |                         |
| 4.  |  |                                   |                                |                             |  |                     |   |                        |   |  |  |                      |  |  |   |  |                    |                        |                         |
| 5.  |  |                                   |                                |                             |  |                     |   |                        |   |  |  |                      |  |  |   |  |                    |                        |                         |
| 6.  |  |                                   |                                |                             |  |                     |   |                        |   |  |  |                      |  |  |   |  |                    |                        |                         |
| 7.  |  |                                   |                                |                             |  |                     |   |                        |   |  |  |                      |  |  |   |  |                    |                        |                         |
| 8.  |  |                                   |                                |                             |  |                     |   |                        |   |  |  |                      |  |  |   |  |                    |                        |                         |
| 9.  |  |                                   |                                |                             |  |                     |   |                        |   |  |  |                      |  |  |   |  |                    |                        |                         |
| 10. |  |                                   |                                |                             |  |                     |   |                        |   |  |  |                      |  |  |   |  |                    |                        |                         |
| 11. |  |                                   |                                |                             |  |                     |   |                        |   |  |  |                      |  |  |   |  |                    |                        |                         |
| 12. |  |                                   |                                |                             |  |                     |   |                        |   |  |  |                      |  |  |   |  |                    |                        |                         |
| 13. |  |                                   |                                |                             |  |                     |   |                        |   |  |  |                      |  |  |   |  |                    |                        |                         |
| 14. |  |                                   |                                |                             |  |                     |   |                        |   |  |  |                      |  |  |   |  |                    |                        |                         |
| 15. |  |                                   |                                |                             |  |                     |   |                        |   |  |  |                      |  |  |   |  |                    |                        |                         |
| 16. |  |                                   |                                |                             |  |                     |   |                        |   |  |  |                      |  |  |   |  |                    |                        |                         |
| 17. |  |                                   |                                |                             |  |                     |   |                        |   |  |  |                      |  |  |   |  |                    |                        |                         |
| 18. |  |                                   |                                |                             |  |                     |   |                        |   |  |  |                      |  |  |   |  |                    |                        |                         |
| 19. | 127 dB SPL   | 130                               | 0-90                           | 0-120 dB SPL                | 0-120 dB SPL                                 | 0-126               | 0-126   | 0-129                  | 0-129                                       | 159  | 113- Manually 155- Program                 | 140                  | 0-120                                      |  | 130   | 0-110  | 0-95               | 0-120                  | 0-130                   |
| 20. | 1  | 5                                 | 10                             | 1                           | 1  | 2                   | 1   | 10                     | 2   | 5  | 2 or 5                                     | 1                    | 1  |  | 5   | 5  | 5                  | 1                      | 1                       |
| 21. | 125 to 8K + 12K + 15K  | 125 to 8K + 12K + 16K             | 500 Hz, 1K, 2K                 | 250-8K                      | 250-8K                                       | 250-8K              | 250-8K  | 250-8K                 | 250Hz, 500 Hz, 1K, 1.5K, 2K, 3K, 4K, 6K, 8K | 250Hz, 500Hz, 1K, 1.5K, 2K, 3K, 4K, 6K, 8K | 250Hz, 500Hz, 1K, 1.5K, 2K, 3K, 4K, 6K, 8K | 250-8K               | 20 Hz-10K                                  | 125 Hz, 250 Hz, 500 Hz, 750 Hz, 1K, 5K,            | 2K, 4K, 150 and 400 msec click  | 125Hz, 250Hz, 500Hz, 750Hz, 1K, 1.5K, 2K, 4K, 5K, 8K | 40 Hz, 16K         | 250-8K                 |                         |
| 22. | TDH-49   | TDH-49                            | Miniature Receiver             | TDH-49                      | TDH-49                                       | TDH-39              | TDH-39  | Telex 1470 (Shielded)  | Telex 1470A                                 | TDH-39P & magnetic Shielded Headset        | TDH-39                                     | TDH-39P              | Telex 1470A                                |  | 2K, 2.5K, 3K, 4K, 6K, 8K  | Telex 1470A  | TDH-49             | TDH-49                 | TDH-39                  |
| 23. |  |                                   |                                |                             |  |                     |   |                        |   |  |  |                      |  |  |   |  |                    |                        |                         |
| 24. |  |                                   |                                |                             |  |                     |   |                        |   |  |  |                      |  |  |   |  |                    |                        |                         |
| 25. |  |                                   |                                |                             |  |                     |   |                        |   |  |  |                      |  |  |   |  |                    |                        |                         |
| 26. |  |                                   |                                |                             |  |                     |   |                        |   |  |  |                      |  |  |   |  |                    |                        |                         |
| 27. |  |                                   |                                |                             |  |                     |   |                        |   |  |  |                      |  |  |   |  |                    |                        |                         |
| 28. |  |                                   |                                |                             |  |                     |   |                        |   |  |  |                      |  |  |   |  |                    |                        |                         |
| 29. |  |                                   |                                |                             |  |                     |   |                        |   |  |  |                      |  |  |   |  |                    |                        |                         |
| 30. |  |                                   |                                |                             |  |                     |   |                        |   |  |  |                      |  |  |   |  |                    |                        |                         |
| 31. |  |                                   |                                |                             |  |                     |   |                        |   |  |  |                      |  |  |   |  |                    |                        |                         |

## Classification categories

- |   |  |   |
|---|--|---|
| 1. Maximum number of data channels                            | 11. Data reduction and storage of same                 | 22. Earphones (type)                              |
| 2. Mass data storage  | 12. Interface with other computers                     | 23. Bone vibrator                                 |
| 3. Mass data storage includes storage of recording parameters | 13. Automation/programmability                         | 24. Insert type earphones                         |
| 4. On-line artifact rejection                                 | 14. Click stimulus unit                                | 25. Amplifier low-pass settings                   |
| 5. View input mode  | 15. Phase control of click                             | 26. Amplifier high-pass settings                  |
| 6. Interactive cursor   | 16. Gated tone generator unit                          | 27. Calibration for physiological amplifier       |
| 7. Absolute units for cursor readout                          | 17. Phase control of tones                             | 28. Built-in electrode impedance measuring device |
| 8. Difference measurements with cursors                       | 18. Masking noise unit (external filtering capability) | 29. Cognitive response stimulus unit              |
| 9. Plotter  | 19. Attenuator range (dB)                              | 30. Somatosensory stimulus unit                   |
| 10. X-Y or digital plotter                                    | 20. Attenuator stepsize (dB)                           | 31. Visual stimulus unit                          |
|   | 21. Frequencies (Hz)                                   |   |

Chart - Indicates the list of different ERAs manufactured and their product capabilities. Reprinted from Hearing Instruments, Vol.35, No.8, 1984.

### **Procedure to purchase the equipment:**

Certain fixed procedure should be followed to obtain the instrument. This procedure may differ from institution to institution depending on whether it is a private or public establishment.

The following is the procedure to be followed in a government set-up.

- Obtain address of the place where the instrument could be purchased from. These can be obtained from journals, newspapers, booklets, pamphlets, some other institution etc.
- Write an application form to the concerned company/firm and request them for the proforma invoice and the catalogue.

Check the last date of validity on the proforma Invoice on obtaining it. The company sends proforma invoice.

- Process the invoice based on the budget available and the necessity after referring to the catalogue.
- Make copies of the invoice and send to the necessary departments along with justification letter, regarding the purchase.
- The management will deal with the finance matters, foreign exchange etc.

In the private set-up the procedure is almost the same except that the foreign exchange should be obtained from the bank personally.

## CONCLUSIONS

The clinical utilization of the electrophysiology of the audiology function has opened a new era in our ability to diagnose receptive auditory impairment.

During the last three decades there has been a substantial increase in Electric Response Audiometry, due, no doubt, to the development in computer technology and to enhanced insights into auditory physiology.

Now-a-days more and more number of professionals (Otologists, Audiologists, Neurologists, Paediatricians etc.) having their private practice or attached to Government or semi private organizations are going for the purchase of ERA, due to its wide clinical applicability, better insight in patient's problems, efficacy of time and effort and due to sophistication and prestige involved in it.

Although literature offers wealth of information on different types of ERA, its use in different set-ups and the rapidly developing research work involved using it; limited information is available on how to go about choosing the right equipment and the procedure involved in setting it up knowledge of this would provide us a foundation on the which then one can then carry our the clinical or research activity.

Here an attempt is made to provide the reader with this valuable but often neglected information.

As Susan Jelonek (1988) pointed out - there is a need for planning and having a multidimensional business decision taking into consideration. Technology, capital budgeting, competitive advantage and resource requirement before one goes about a purchase of an equipment.

Certain procedures like compiling a test; going through technical specifications become a pre-requisite for ERA instrument purchase. On purchase another herculean task which is of great importance is to determine the location and installation of the equipment. Various factors like acoustic environment, electrical environment need to be taken care-off. While chapter 4 deals with the general and specific consideration for installing the ERA equipments, chapter-5 deals with the factors to be considered for procurement of the equipment.

A brief history and development of ERA is provided in the preceding chapters along with information on individual characteristics, instrumentation and clinical applications.

It is hoped that this primer provides sufficient information and insight regarding purchase of the equipment and its utilisation to the required extent.

## BIBLIOGRAPHY

- Aran et al. (1969):, Cited in "Essentials of clinical electric response -audiometry" by Gibson W.P.R., and Ruben, R.J. (1978). Churchill, Livingston, Edinburgh, P.J-19.
- Beagley, H.A. (1981): "Electrophysiological tests in hearing" in Beagley, H.A. (Ed.) Audiology and Audiological Medicine, Vol.2, P.781-815.
- Berger, H. (1929): Uber das clecktroenkephalogramm des menschen. Archives fur psychiatrie and NervenKranktheiten, 87, 527-570. In Essentials of clinical electric response audiometry, by W.P.R. Gibson (1978), Churchill Livingston, Edinburgh, P.3.
- Brickford et al. (1964): cited in "Essentials of clinical electric response audiometry" by Gibson W.P.R. and Ruben, R.J. (1978), Churchill, Livingston, Edinburgh, P.3-19.
- Burian, Gestring and Haider (1969): cited in "Essentials of clinical electric response audiometry" by Gibson, W.P.R., and Ruben, R.J. (1978) Churchill, Livingston, Edinburgh, P.3-19.
- Clark, et al. (1962): Cited in "Essentials of clinical response audiometry" by Gibson, W.P.R. and Ruben, R.J. (1978). Churchill, Livingston, Edinburgh, P.3-19.
- Coats, A.C., and Dickey, J.R. (1970): "Non surgical recording of human auditory nerve potentials and cochlear microphonics". Annals of Otology, Rhinology and Laryngology, 79, 844-852.
- Cullen, J.K.Jr., Ellis, M.S., Berlin, C.I., and Lousteau, R.J. (1972): "Human acoustic nerve action potential recordings from the tympanic membrane without anaesthesia". Acta Oto-laryngologica, 74, 15-22.
- Davis, H., Hirsch, S.K., Shelnutt, J. and Bowers, O. (1967): "Further validation of evoked response audiometry", JSRH, 10, 717-73. ,
- D'Mello, J. and Samuel, J.D. (1982): "A few suggestions to the organisation of a speech and hearing centre in a hospital". Hearing Aid Journal, Vol.3, No.3, P.7-15.

- Geisler et al. (1958): Cited in "Essentials of clinical electric response audiometry" by Gibson, W.P.R., and Ruben, R.J. (1978). Churchill, Livingstone, Edinburgh, P.3-19.
- Gibson, W.P.R., and Ruben, R.J. (1978): "Essentials of clinical response audiometry". Churchill, Livingston, Edinburgh.
- Glatcke, T.J. (1978): "Electrocochleography" Pp.328-343. in Katz, J. Ed. 2nd. ed. 'Handbook of clinical audiology', Baltimore, Waverly Press Inc.
- Hallen, and Sheldon (1976): Cited in D'Mello, J. and Samuel, J.D., "A few suggestions to the organisation of a speech and hearing centre in a hospital". Hearing Aid Journal (1982), p.7-15.
- Harker et al. (1977): Cited in "Essentials of clinical electric response audiometry" by Gibson W.P.R. and Ruben, R.J. (1978). Churchill, Livingston, Ediburgh, P.3-19.
- Hecox, K., and Galambos, R. (1974): "Brainstem auditory evoked response in human infants and adults". Archives of Otolaryngology, 99, 30-33.
- Jacobson, J.T., and Hyde, M.L. (1985): "An introduction to auditory evoked potentials" P.496-533 in Katz, J. ed. Handbook of clinical audiology, Baltimore, Waverly Press Inc.
- Jewett, D.L., and Williston, J.S. (1971): "Auditory evoked farfields averaged from the scalp of humans". : Brain,=94, 681-696.
- Katz, J. (Ed.) (1978): "Handbook of clinical audiology". 2nd Edition, Williams and Williams, Baltimore
- Madsen, P., and Hansen, B.s. (1972): "Considerations for procurement of an ERA system. Scandinavian Audiology, Supplement No.13, P.155-161.
- Moushegian, Rupert- and Stillman (1973): Cited in "Essentials of clinical electric response audiometry" by Gibson, W.P.R. and Ruben, R.J. (1978), Churchill, Livingston, Edinburgh, P.3-19.

- Murthy, S.s., and Jacob, K.T (1970): "Sound treated room in a speech and hearing clinic". JAIISH, p.87-91.
- Musiek, et al. (1984): "Past, present and future applications of the auditory middle latency response". Laryngoscope, 94, 1545-1553.
- Pfeiffer, R.R. (1974): "Consideration of the acoustic stimulus" p.9-38 in 'Handbook of sensory physiology. Volume V/1 Ed. Keidel, W.D. and Neff, W.D. Springer-Verlag, Berlin, Heidelberg, New York.
- Plutchik (1967): "Role of instruments in research" in Foundations of experimental research. Harper and Row, Publishers, London, P.238-256.
- Portman, et al. (1967): Cited in "essentials of clinical electric response audiometry" by Gibson W.P.R. and Ruben, R.J. (1978) Churchill, Livingstone, Edinburgh, P.3-19.
- Premalatha, B.S. (1980): "Electric response audiometry - Principles and its application". An unpublished Independent Project, University of Mysore.
- Price, L.L. (1969): "Evoked response audiometry - some considerations", JSHD, 34, P.137-141.
- Ronis (1966): Cited in "Essentials of clinical response audiometry" by Gibson, W.P.R., and Ruben, R.J. (1978). Churchill, Livingstone, Edinburgh, P.3-19.
- Ruhm, et al. (1967): cited in "Essentials of clinical electric response audiometry" by Gibson W.P.R. and Ruben, R.J. (1978), Churchill, Livingstone, Edinburg, P.3-19.
- Sheperd, D.C., Wever, O.R. and McCarren, K. (1970): Techniques to reduce the negative effects of high voltage electrical artifacts during averaged electroencephalic audiometry (AEA). JSHD, Vol.35, No,2, p.141-155.
- Sohmer, H. and Feinmesser, M. (1973): "Routine use of electro cochleography (cochlear audiometry) on human subjects". Audiology,12, 167-173.

- Stockard et al. (1983): "Prognostic value of brainstem auditory evoked potentials in neonates". Arch.Neural. 40, 360-365.
- Susan Jelonek (1988): The 'good' buy: How to purchase equipment more successfully. Hearing Instruments, Vol.39, No.3.
- Teas et al. (1962): cited in Glattko, T.J. "Electrocochleography" in Katz, J. (1979): Handbook of clinical audiology. Ed. 2, Baltimore, Waverly Press Inc, P.328-343.
- Walter, et al.(1964): Cited in "Essentials of clinical electric response audiometry" by Gibson W.P.R. and Ruben, R.J. (1978), Churchill, Livingston, Edinburgh, p.3-19.
- Wever and Bray (1930): Cited in Feerraro, J.A. "Electro - cochleography" in Owen J.H. and Donohoe, C.D. (Ed.) (1988) 'Clinical atlas of auditory evoked potentials'. Orlando Grune and Stratton Inc, P.1-13.
- Yoshie, N. and Yamaura, K. (1969): "Cochlear microphonic responses to pure tones in man/recorded by a non-surgical method". Acta Otolaryngologica Supplementum 252, 37-69.