

LOOK. READ AND ANSWER: A PROGRAM ON HEARING AIDS

Reg.No.M9022

**AN INDEPEDENT PROJECT WORK SUBMITTED AS PART
FULFILMENT FOR THE FIRST YEAR M.Sc. (SPEECH &
HEARING) TO THE UNIVERSITY OF MYSORE, MYSORE.**

**ALL INDIA INSTITUTE OF SPEECH AND HEARING,
MYSORE, 1991**

CERTIFICATE

This is to certify that the Independent Project entitled " Look, Read and Answer: A Program on Hearing Aids " is the bonafide work done in part fulfilment for First Year M.Sc., (Speech and Hearing) of the student with Register No.M9022.

Mysore
1991

A11

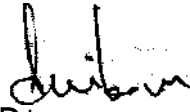
Director
India Institute
of Speech & Hearing
Mysore-6.

CERTIFICATE

This is to certify that the Independent Project entitled: "Look, Read and Answer: A Program on Hearing Aids " has been prepared under of supervision and guidance.

Mysore
Guide

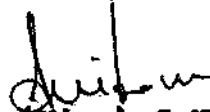
Dr. (Miss) S. Nikam.

DECLARATION

This independent project entitled "**LOOK, READ AND ANSWER: A PROGRAM ON HEARING AIDS**" Is the result of my own study undertaken under the guidance of Dr. (Miss) Nikam, prof. & Head of the Department of Audiology, All India institute of speech & Hearing, Mysore and has not been submitted earlier at any University for any other Diploma or Degree.

Mysore

Reg. No.M 902.2.

ACKNOWLEDGEMENTS

I am indebted to Dr.(Miss) S.Nikam, Prof, and Head of the Department of Audiology, for her guidance and supervision.

I am grateful to Dr.(Miss) S.Nikam, Director, for allowing me to do the project.

I am also thankful to Mrs. sowmyamala, Mrs.Roopa, N. Mrs.Asha, Y. Mrs.Hemalatha and Ms.Manjula for providing me some valuable information.

My thanks are also due to Ms.Shailashree C.N. and Ms.Pragna Gokani for giving me the true picture of my project and helping me in either correcting or accepting the matter.

I thank Mrs. Rajalakshmi, for her great patience and cooperation in typing my project.

My thanks to the artist Mr.Ganeshaiyah for generously leading his artistic hand throughout the project.

Finally I thank my parents and pati for giving me all the encouragement, my special thanks to my brother.

OUR DEAREST AKHILA

WHO IS SO FAR

YET SO NEAR .

TABLE OF CONTENTS

	PG
INTRODUCTION	1
ERA IN HEARING INSTRUMENTS I	3
AMPLIFICATION SYSTEM - I	4
AMPLIFICATION SYSTEM - II	5
BLOCK DIAGRAM OF A HEARING AID	6
MICROPHONE	7
CORDS	8
EARMOLDS	9
TYPES OF AMPLIFICATION SYSTEMS- I	10
TYPES OF AMPLIFICATION SYSTEMS - II	11
TYPES OF AMPLIFICATION SYSTEMS - III	12
TYPES OF AMPLIFICATION SYSTEMS - IV	13
ELECTROACOUSTIC CHARACTERISTICS - I	14
ELECTROACOUSTIC CHARACTERISTICS - II	15
ELECTROACOUSTIC CHARACTERISTICS - III	16
AUDIOGRAM AND AMPLIFICATION - I	17
AUDIOGRAM AND AMPLIFICATION - II	18
AUDIOGRAM AND AMPLIFICATION - III	19
AUDIOGRAM AND AMPLIFICATION - IV	20
AUDIOGRAM AND AMPLIFICATION - V	21
A STEP IN REHABILITATION PROCEDURE	22
ASSESSMENT PROCEDURE	23
MODES OF AMPLIFICATION	24
HEARING AID MAINTENANCE	25
ASSISTIVE LISTENING DEVICES	26
ERA IN HEARING INSTRUMENTS-II	27
ANSWERS	28
BIBLIOGRAPHY	73

INTRODUCTION

"When the deaf child slaps, the whole world swings".

Hearing aids are the most important resources available for the habilitation of hearing impaired individuals.

ASHA has defined audiological habilitation as a comprehensive process including developmental and restorative procedures in audiological language processing as well as the traditional aural rehabilitative programs of auditory training and speech reading instruction. Amplification is an important aspect in audiological habilitation. The importance of optimal amplification to the audiological habilitative procedure require that audiologists assume a major role in the selection of the client's hearing aids. This in turn requires extensive knowledge of hearing aids; their types, the components, physical and electroacoustic characteristics, assessment and hearing aid maintenance.

This project aims at providing such information to the students who are getting moulded into audiologists. The reader is suggested to make a pre and post test evaluation so as to figure out how much he/she knows about the most significant thing in another person's a deaf person's life.

So, lets start at the very beginning; a very good time to start. When we start,we begin with... historical development of hearing aids.

Well,"look" at the pictures, "read" the questions and provide the "answers".

ERA IN HEARING INSTRUMENTS - I

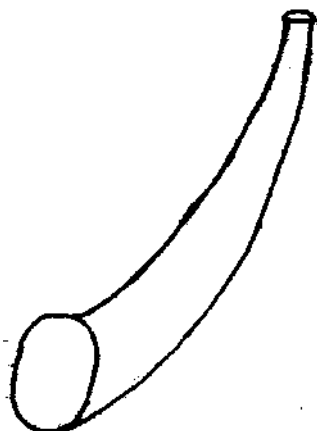

1. Name the object shown above.
2. What was this made of?
3. What purpose did it serve?
4. Name a few such devices.
5. What other aids were developed after this to serve the same purpose?

AMPLIFICATION SYSTEM - I

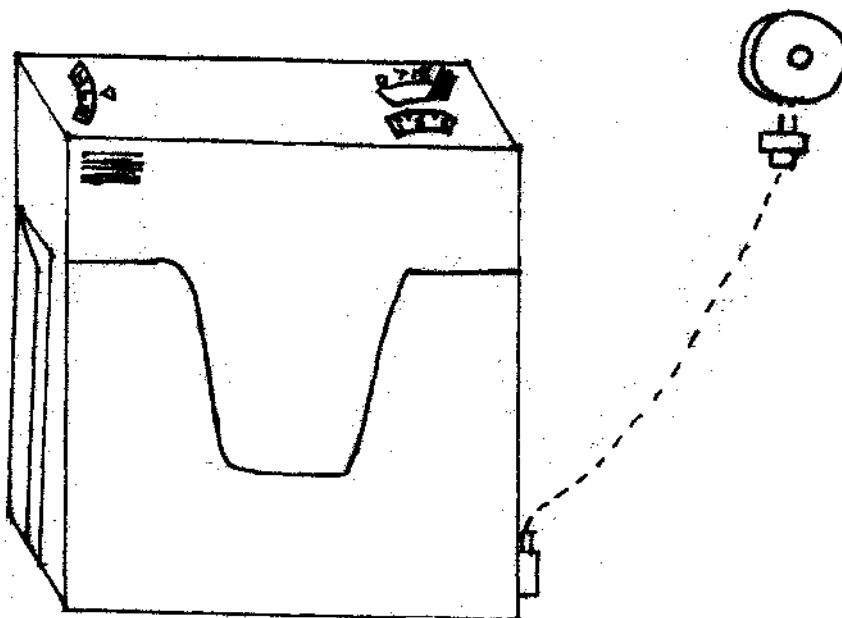

1. What is this a picture of?
2. What is it used for?
3. Who finds this useful?
4. What are the different types of this system?
5. What are the different accessories required?
6. What specifications does it have to meet?

AMPLIFICATION SYSTEM - II

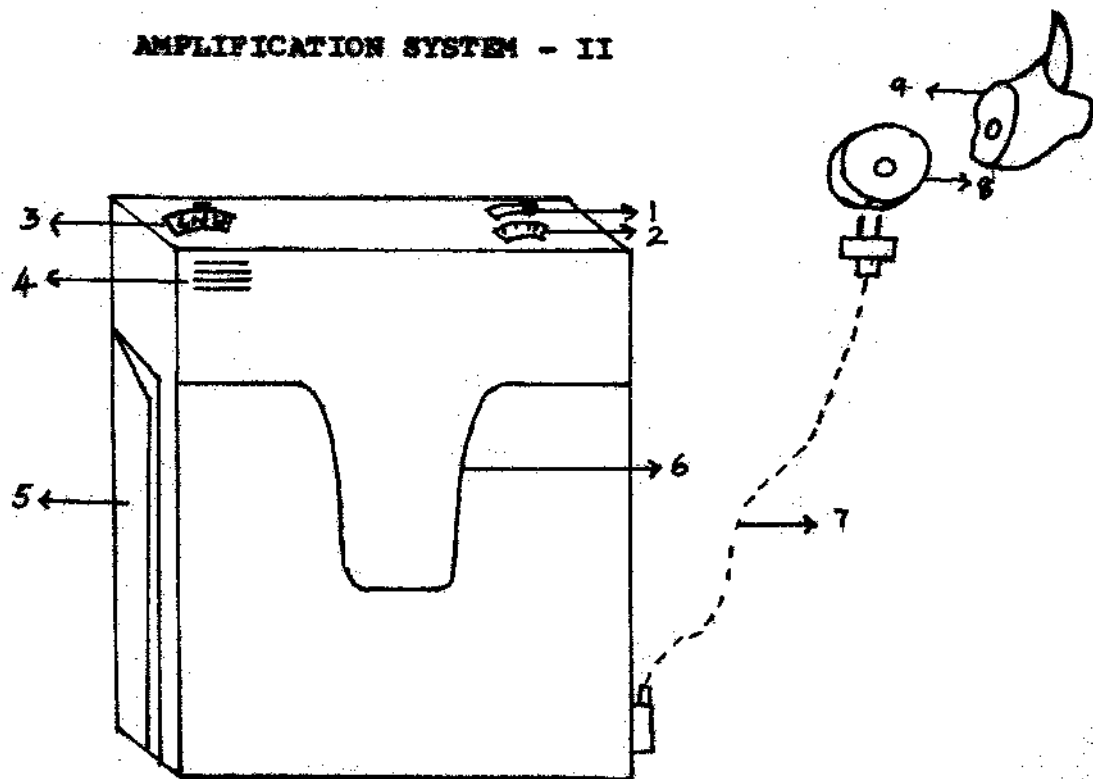

1. Name the basic parts of a body level hearing aid.
2. Give the usage of each of the basic parts.
3. What is the consequence if any of the parts mentioned below is missing; Give one sentence for each part.
 - (a) Receiver
 - (b) Microphone
 - (c) Earmold
 - (d) Battery
 - (e) Clip
 - (f) Variable volume control
4. Name the replacements; if no replacement is appropriate, what can be done next?

BLOCK DIAGRAM OF A HEARING AID

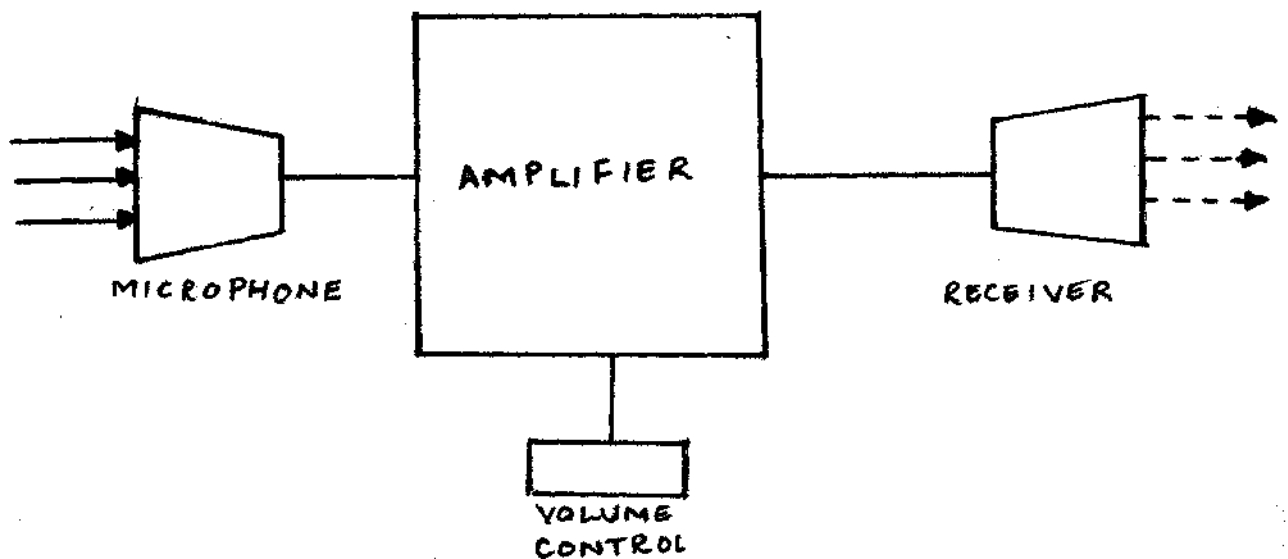

1. What is missing in the block diagram?
2. What is the use of the part that is missing?
3. Does it have any specific value of its quantity?
4. What are the different types of the part Which is missing?
5. Why is it placed separately from the amplification system or the P.CB. of the hearing aid?
6. How does it affect the working of the hearing aid?

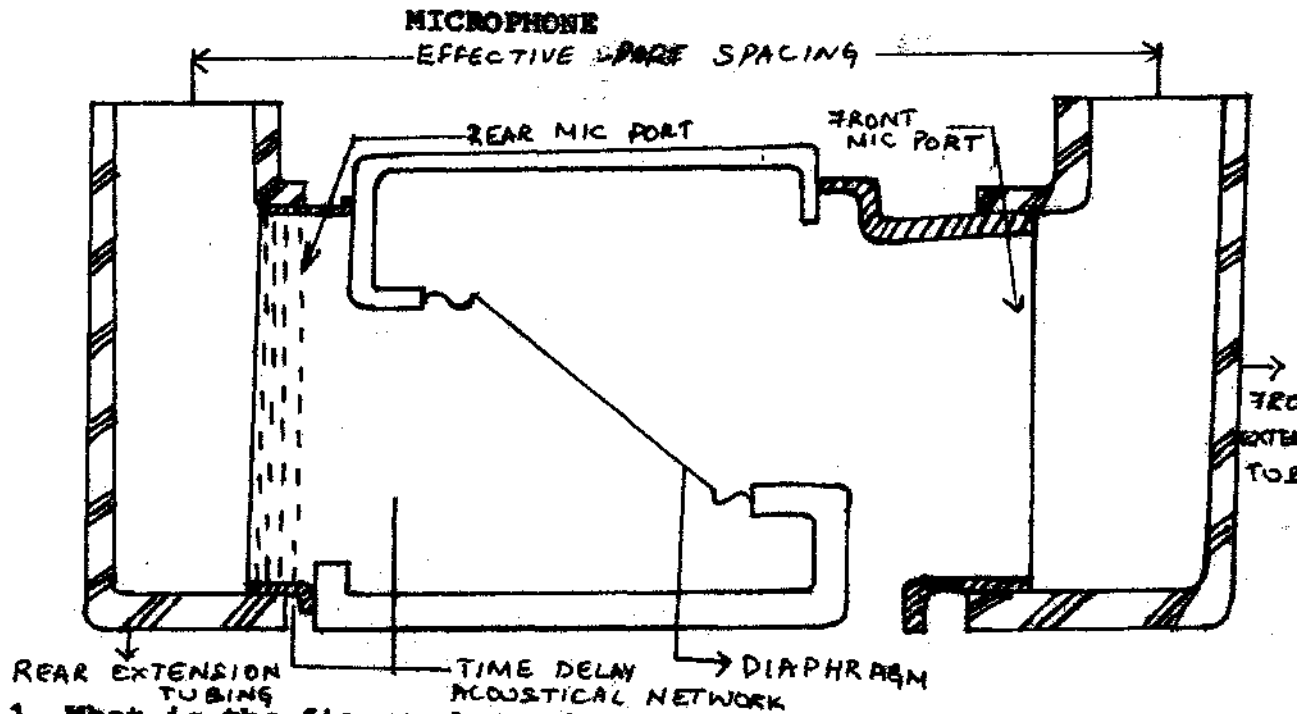

1. What is the figure shown above?

2. Define the term.

3. How does it work?

4. What are its advantages?

5. What are the disadvantages?

CORDS

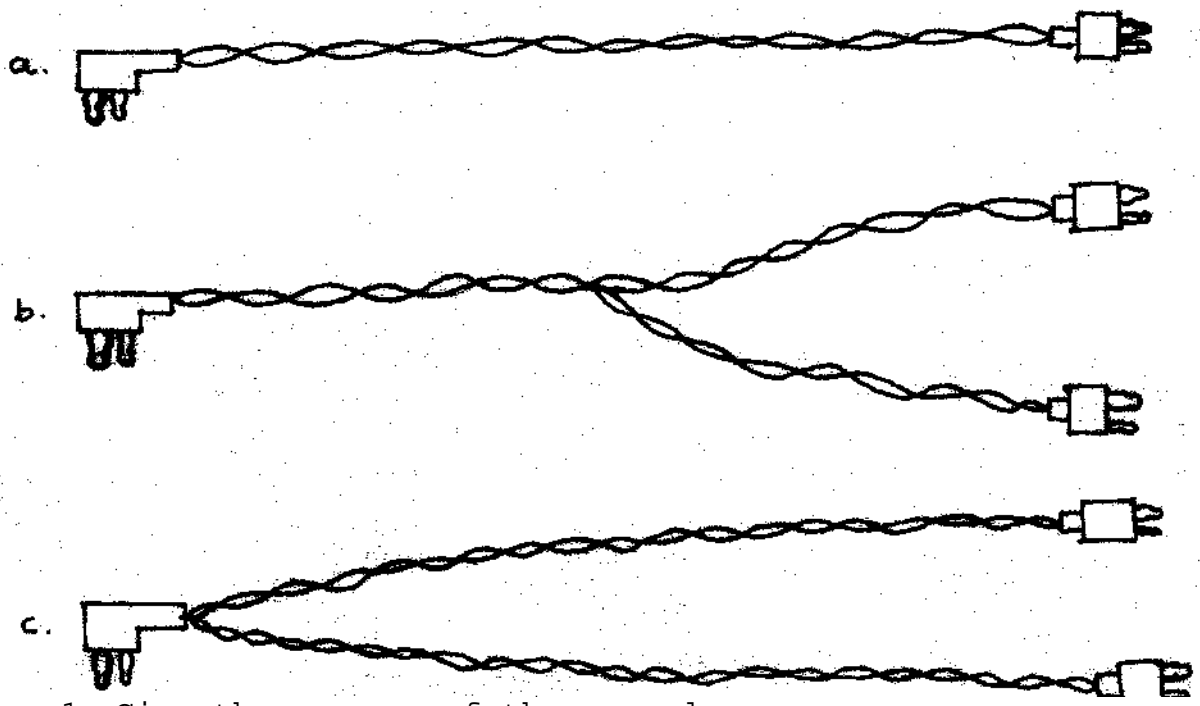

1. Give the purpose of these cords.
2. What are the different types of cords shown above?
How else can they be classified?
3. Draw the circuit diagram of each of the cords shown above and mention the differences.
4. Under what circumstances are these different cords used?
5. Mention the different accessories which may be used with cords, and give their functions.
6. What specifications are to be met by the cords?
7. How can these cords be made to last longer?

EARMOLDS

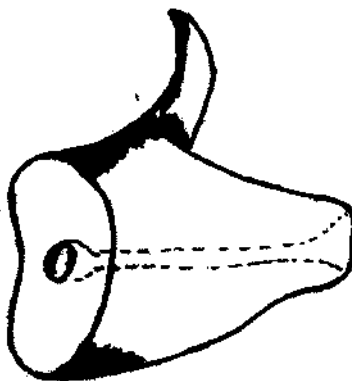

1. What is an earmold? What are the other names by which it is known?
2. What are the variations of earmolds?
3. Mention briefly the functions of an earmold.
4. What may be done to the earmold so as to modify sound?
5. Name some accessories which can be attached to the earmolds.
6. Prepare a table showing different types of earmolds used with different types of hearing aids.
7. What are the instructions to be given regarding maintenance of an earmold?

TYPES OF AMPLIFICATION SYSTEMS-I

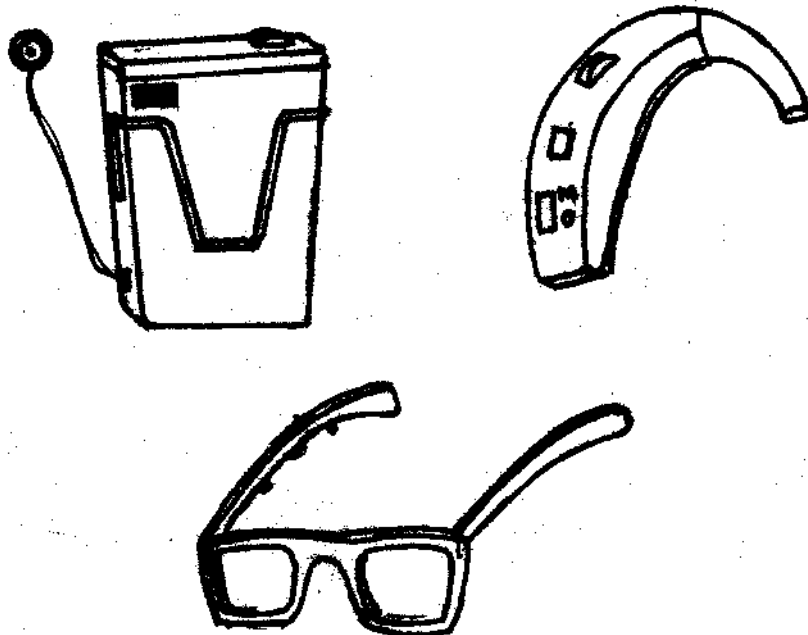

1. Identify these amplification systems.
2. How can these be classified broadly?
3. What factors do we need to consider while selecting these hearing aids?
4. What are the parameters which differentiate one aid from the other?
5. How else can hearing aids be classified?
6. When is the use of each type indicated?

TYPES OF AMPLIFICATION SYSTEMS - II

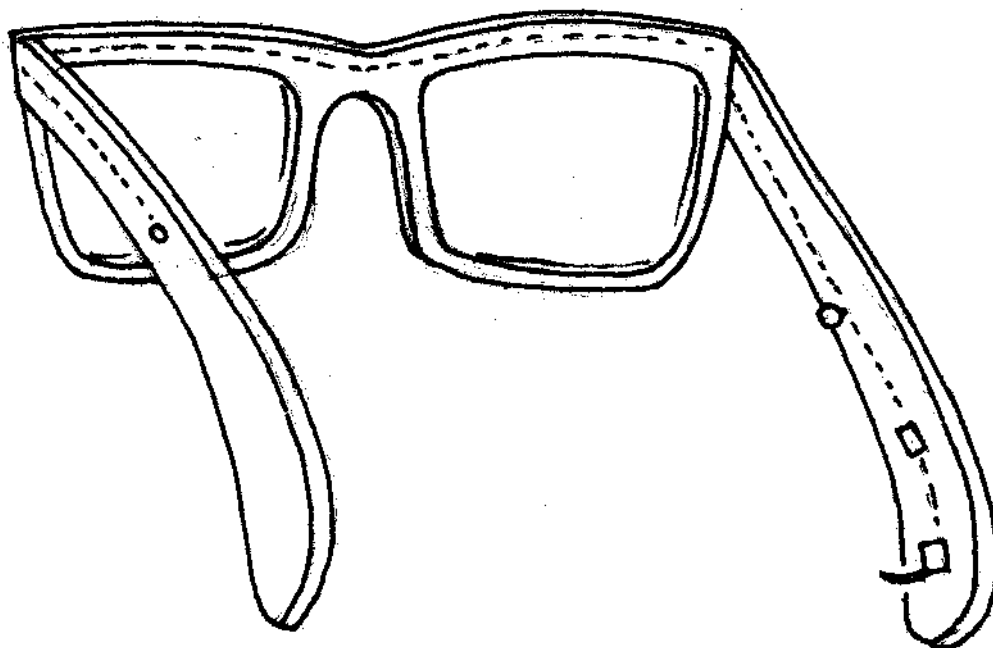

1. What is *the* amplification system shown above known as?
Why is it called so?
2. What types of hearing aids can provide this kind of amplification?
3. What are the advantages of using such hearing aids?
4. Name some of the hybrids or variations of these aids.
5. What criteria need to be taken into consideration while recommending this type of hearing aid and its hybrids?

TYPES OF AMPLIFICATION SYSTEMS - III

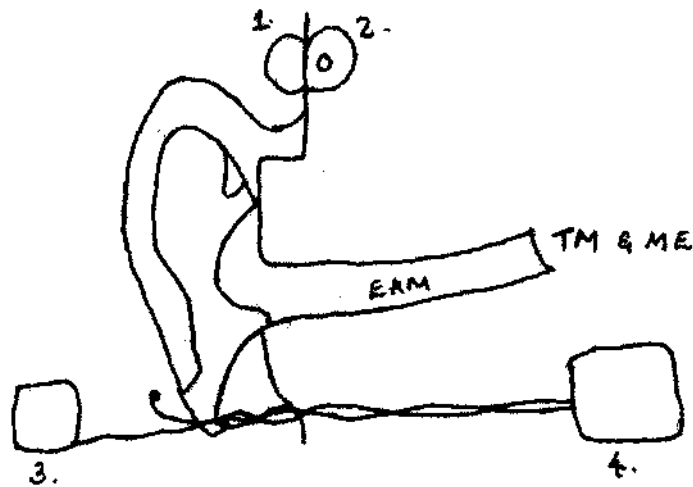

1. Name the amplifying system shown above.
2. Name the components of this system.
3. What are its advantages?
4. Give the drawbacks of this system.
5. What conditions have to be considered before recommending this aid?

TYPES OF AMPLIFICATION SYSTEMS - IV

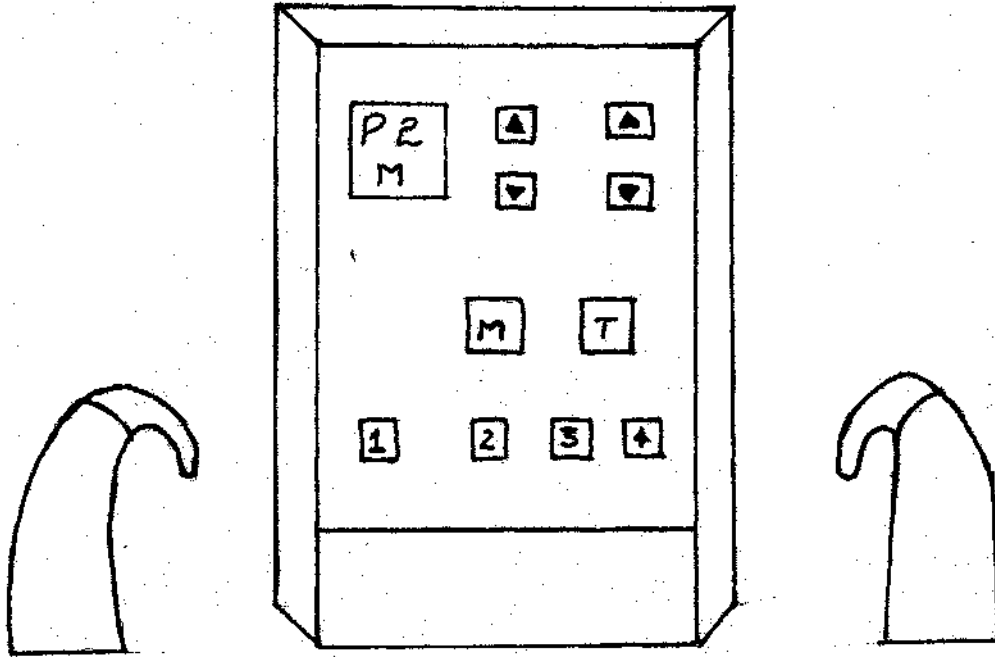

1. Name the instrument shown above.
2. Give the function of the centre instrument
3. Explain what each key implies.
4. What are the requirements for the behind-the-ear hearing aid shown above which need to be used?
5. List some advantages of this instrument.

ELECTROACOUSTIC CHARACTERISTICS-I

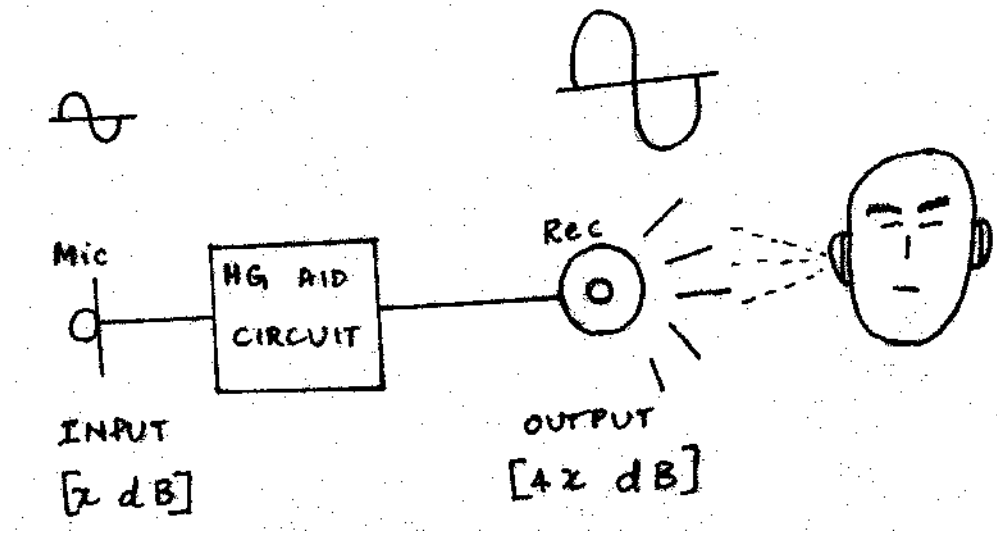

1. What does this hearing aid circuit lack?
2. How can the phenomenon of output limiting be brought about? Which technique is preferred and why is it so?
3. Output limiting occurs after reaching a point of
4. What are the critical variables in a compression system?
5. Give the schematic diagram of an output compression hearing aid.

ELECTROACOUSTIC CHARACTERISTICS - II

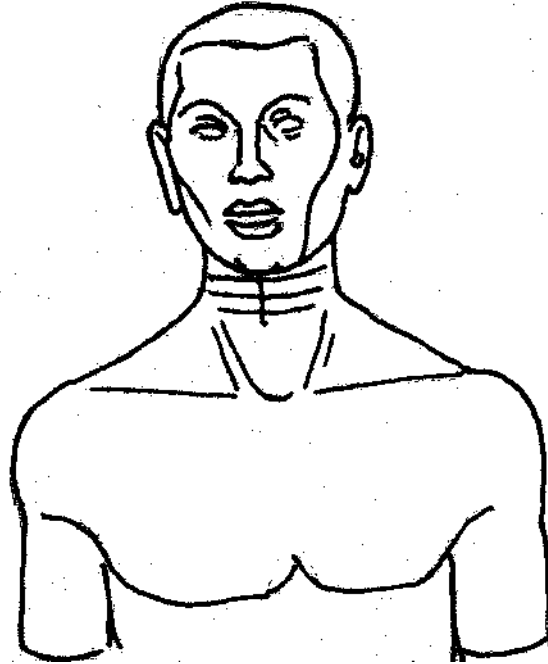

1. What does KEMAR stand for?
2. Why are such models found useful?
3. what does KEMAR consist of?
4. What are the electroacoustic evaluations which can be done with KEMAR?
5. Are there other models similar to *KEKAR*?

ELECTROACOUSTIC CHARACTERISTICS - III

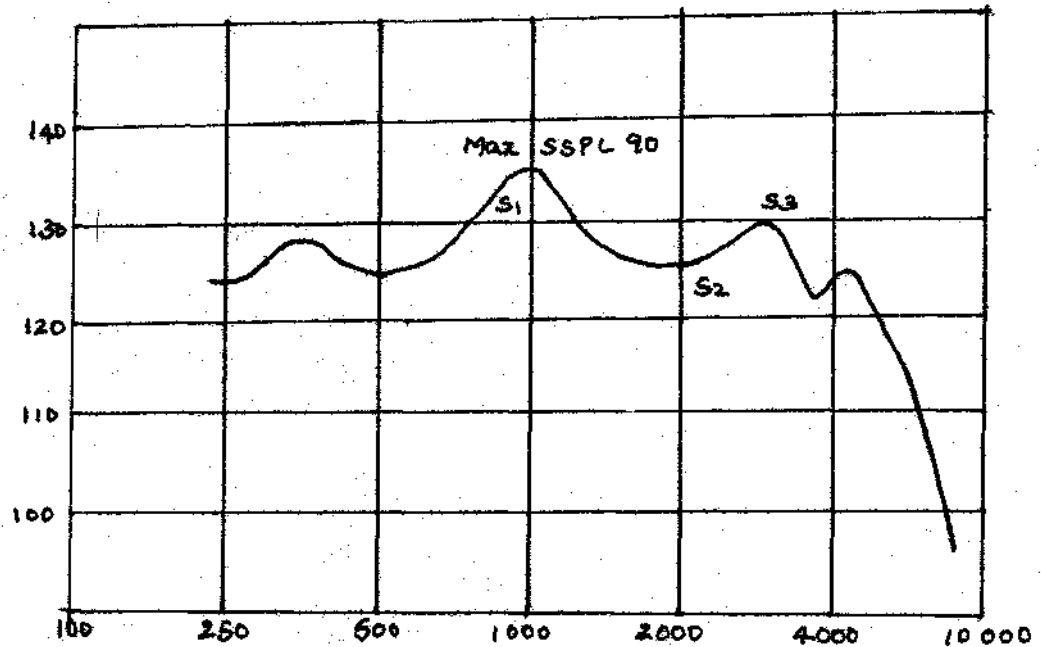

1. What does this graph represent:? What is shown em x-axis and en y-axis?
2. What is the rationale behind the electroacoustic measurements?
3. What are the other electroacoustic characteristics? Define each of them.
4. Give a list of the environmental requirements to make electroacoustic measurements.
5. What are the different phenomena of feedbacks in hearing aids and how can they be overcome?
6. How can the curve or the graph be modified?
7. In how many ways can the curve be recorded?
8. Can more than one recording be made on the same graph? When would this be desirable?

AUDIOGRAM AND AMPLIFICATION - I

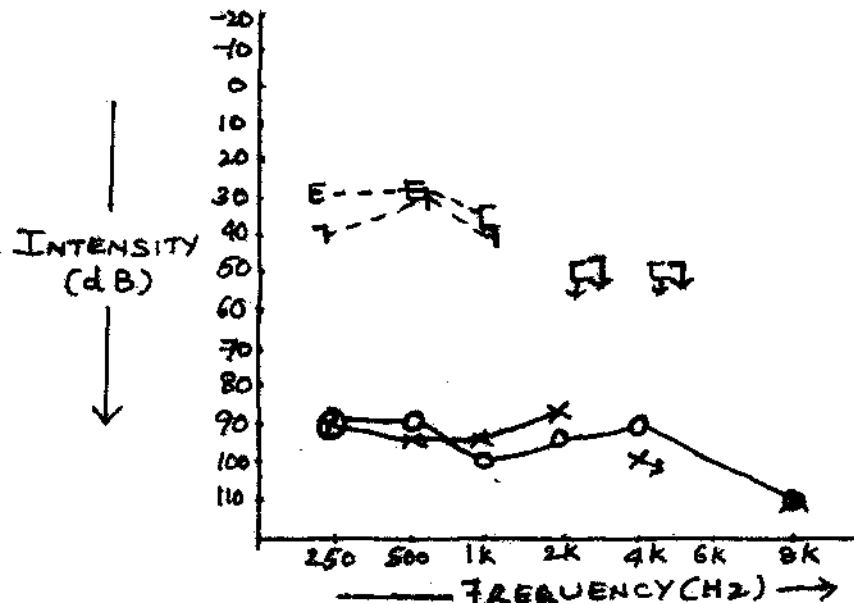

- 1 . Unscramble the anagram ETALCTI to find the type of amplification system which is used in the rehabilitation of this case with profound loss.
2. To whom else can this be recommended?
3. Give some advantages of this type of aid.
4. What are the disadvantages of the same?
5. How is it different from other hearing aids?
6. Where is it placed on the user?

AUDIOGRAM AND AMPLIFICATION - II

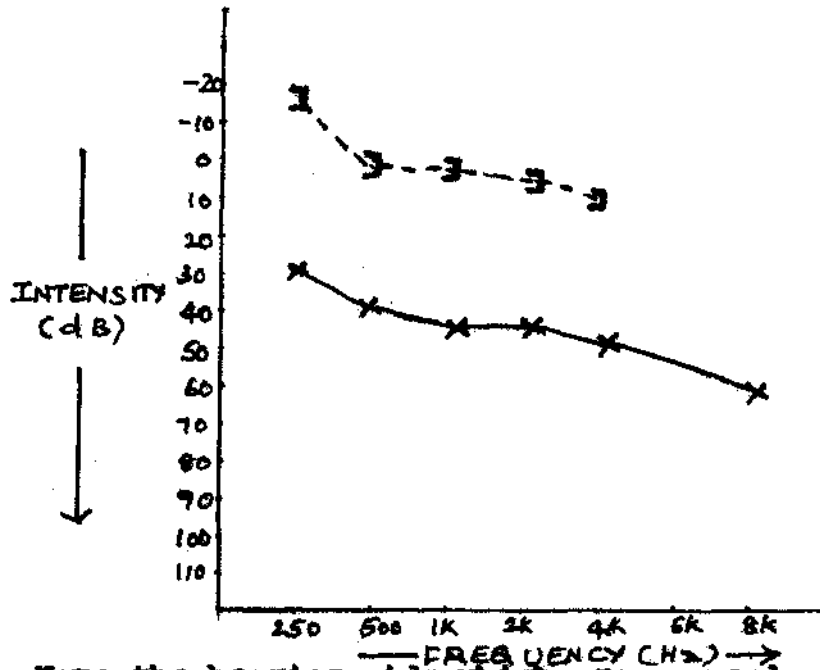

1. Name the hearing aids which are commonly prescribed

for this conductive loss case, especially with a discharging ear.

2. When are these hearing aids preferred?
3. How is this different from the amplification used for a case with sensori-neural hearing loss?
4. What factors need to be considered while amplifying the conductive hearing loss cases?
5. Who has greater difficulty in communication—a person with conductive hearing loss or a person with sensori-neural hearing loss with recruitment? Why is it so?

AUDIOGRAM AND AMPLIFICATION - III

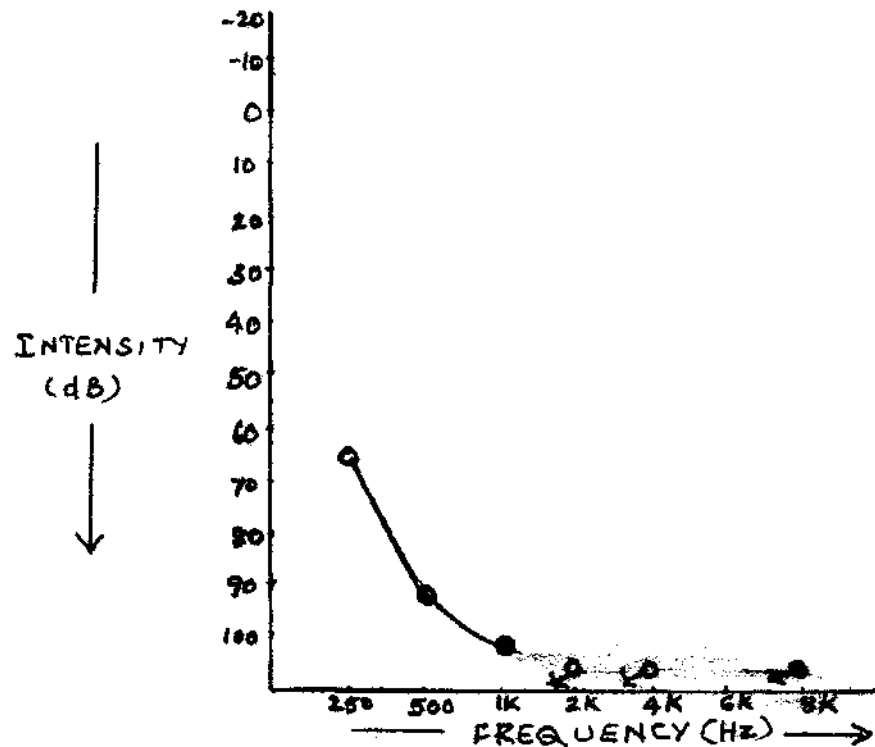

1. Which frequencies are preferred to be amplified or emphasized?
2. What modes of amplification of sound may be used here?
3. What is frequency transposition?
4. How can it be applied here?
5. What are the problems encountered with frequency transposition?

AUDIOGRAM AND AMPLIFICATION - IV

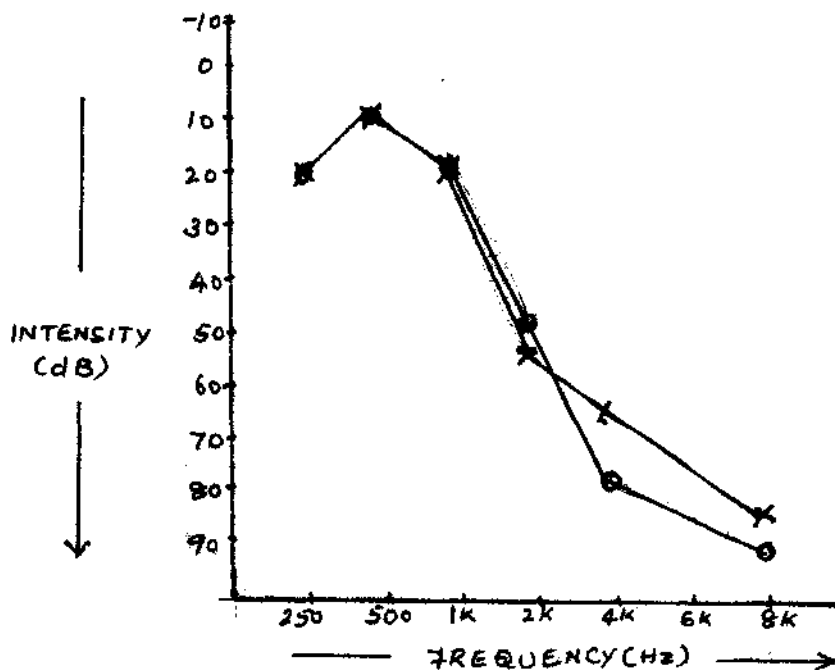

1. Is amplification suggested at this stage?
2. If the condition deteriorates, which type of amplification is recommended.
3. Usually what earmolds are helpful with this type of hearing loss and this amplification system? And, why is it so?
4. Which ear is preferred to be amplified if the hearing loss

in the left ear is of moderate severity and severe in the right ear? What criteria is followed so as to

to the person with this kind

AUDIOGRAM AND AMPLIFICATION - V

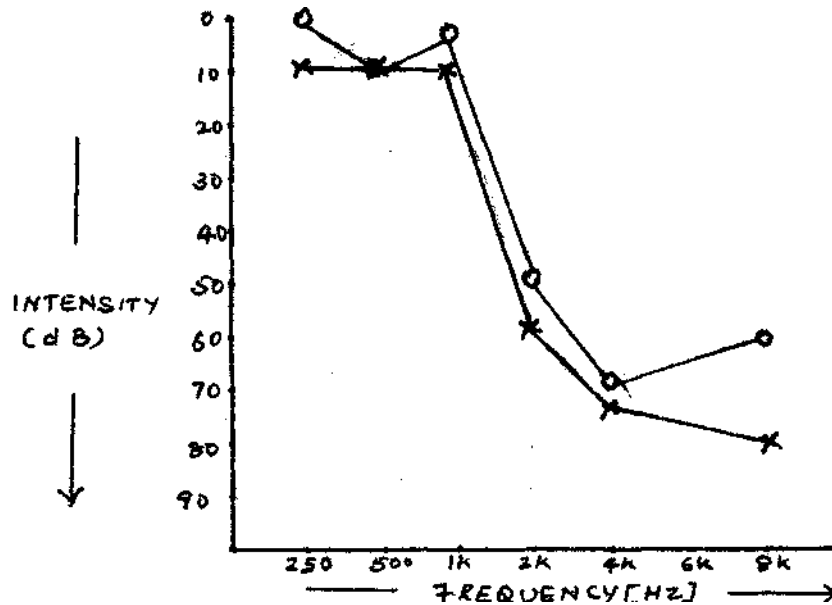

1. Name the hearing aids which are recommended in this case?
2. Give the reasons for selecting them.
3. Is there any specific type of earmold which proves to be most effective with these hearing aids? If so, which type?

A *STEP* IN REHABILITATION PROCEDURE

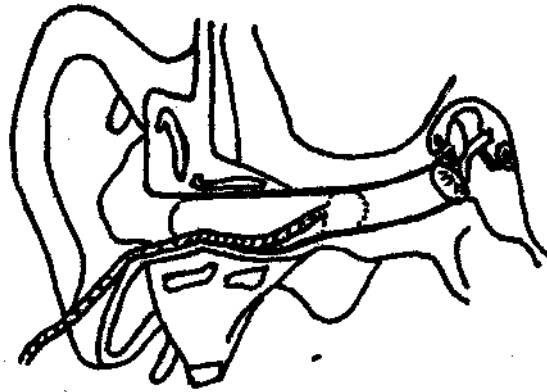

1. What is shown in the figure? Why is it necessary?
2. What are the instruments used here?
3. What are the different materials used to take the impression?
4. What modifications can be made while preparing an earmold?
5. Give some merits and demerits of hard and soft earmolds.

ASSESSMENT PROCEDURE

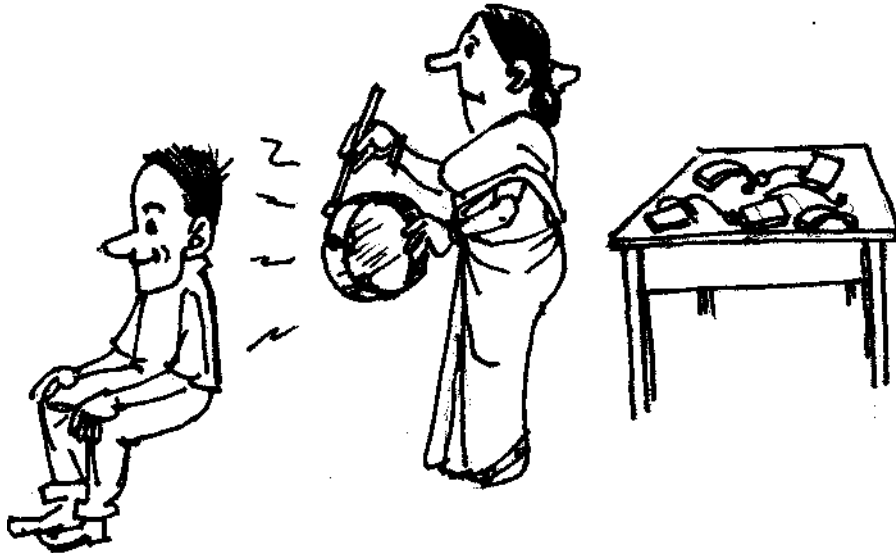

1. What activity is shown above?
2. Name the different types of this procedure.
3. List down the factors to be considered.
4. How do the procedures involved in this vary across age?
5. What diagnostic tests are the pre-requisites for this procedure?
6. Regarding what may an elderly person with acquired hearing loss who has been prescribed hearing aid be counselled?

MODES OF AMPLIFICATION

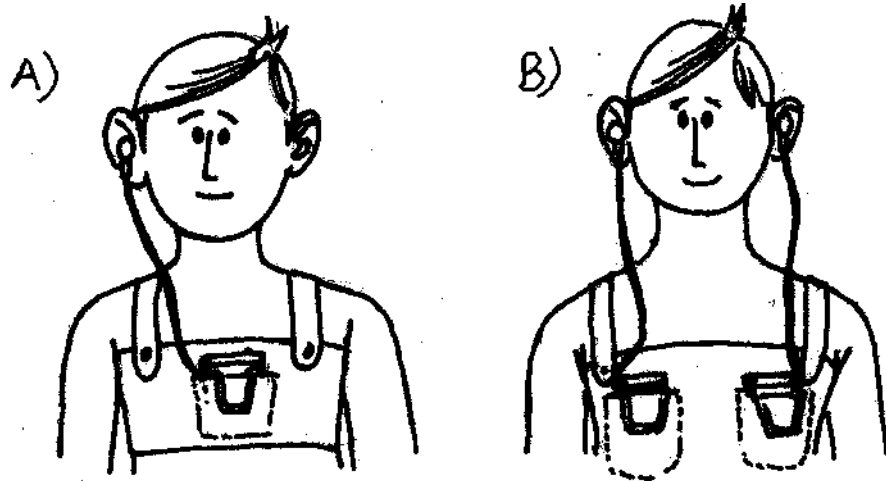

1. What are these listening conditions called as?
2. Give the merits of each.
3. What are the demerits of each?
4. Which condition is confused with binaural hearing commonly? How is it different from binaural hearing?
5. what instructions should be given to a listener who desires binaural amplification?
6. Wich hearing-impaired people can obtain good benefit from binaural hearing aids?

HEARING AID MAINTENANCE

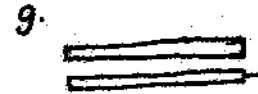
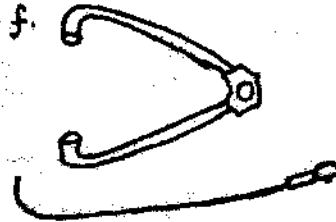
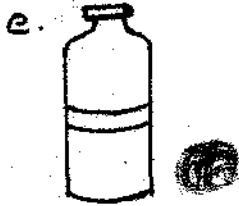
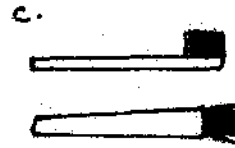
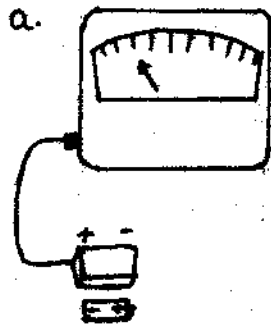

1. Identify the items shown above.
2. Give their functions.
3. Where is it desirable to find these items?
4. Why is hearing aid maintenance program important?
5. How frequently should it be carried out?

ASSISTIVE LISTENING DEVICES

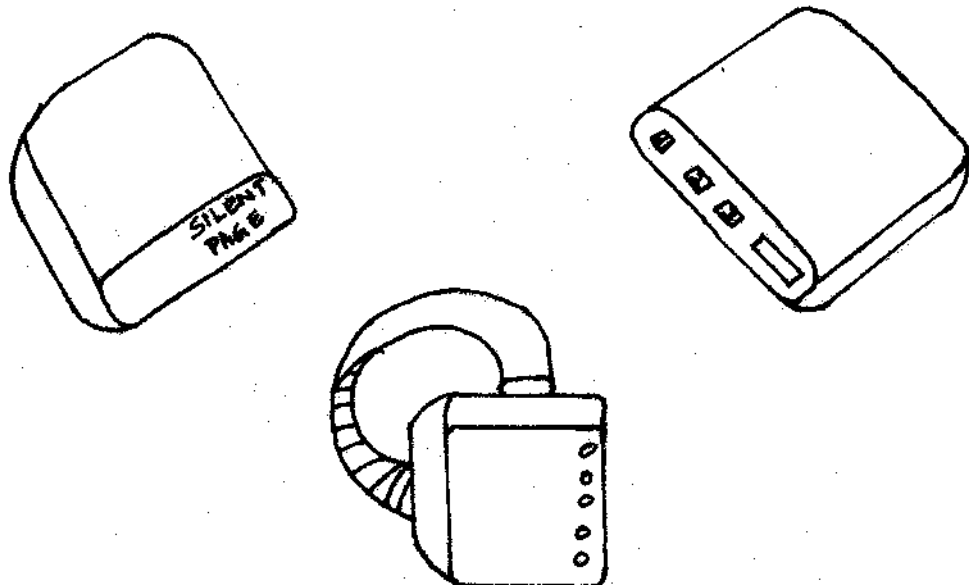

1. Name the instrument shown above.
2. Explain what it is.
3. What are its advantages?
4. What are assistive listening devices?
5. Give a list of some more assistive listening devices;
and some applications of assistive listening devices.

ERA IN HEARING INSTRUMENTS - II

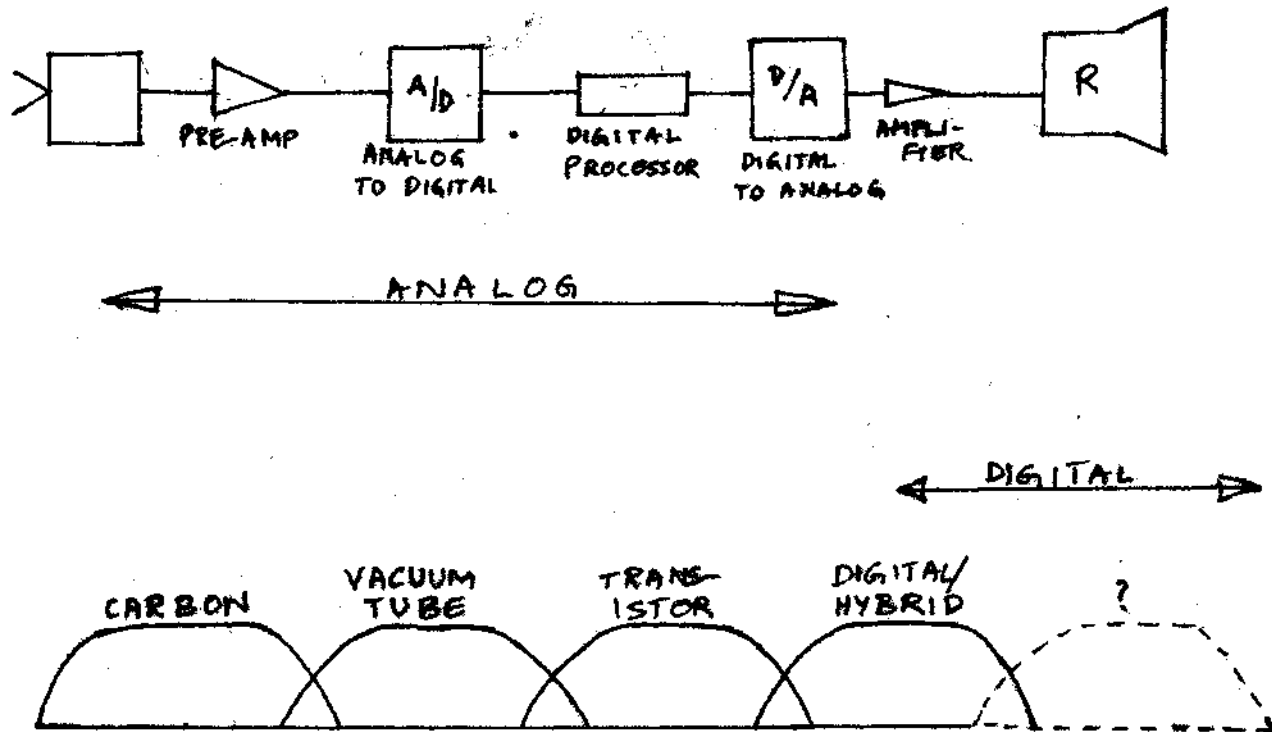

1. What type of hearing instrument is shown here?
2. Give some advantages of this hearing aid.
3. What is the function of the digital processor?
4. What are the limitations of this?
5. Give a block diagram of this hearing instrument.

ANSWERS

I. ERA IN HEARING INSTRUMENTS - I

1. This is a sound collector device called as ear trumpet.
2. This was made of either-thin metal or tortoise shell.
3. This was used in the 17th century, it was initially used by persons with normal hearing and subsequently by hearing impaired individuals. It was used to direct the sound energy into the ear canal.
4. Some of the other such devices or sound collectors are animal horns, speaking and hearing trumpets, ear inserts, and acoustic throne.
5. Acoustic throne was developed by Rein (1819). Fonifero, a bone conductor was developed by Giovanni Paladine (1876) • Ear inserts like Politser ear insert were also introduced. In 1879, the Audiophone, a bone conduction hearing fan was invented by Rhodes of Chicago. The first patented hearing aid was made by Hutchison, M.R. (1898). Telephone coil was introduced to the hearing aid in the year 1936. The electronic hearing aid eyeglass was first manufactured in 1954. The first at ear hearing aid was done in 1955 and/in 1958, the first report of an implanted hearing aid was given. In the early 1960s hearing aids with transistors were manufactured. After this was an end of an era - the Analog hearing aids. Then came the hybrid of Analog and Digital aids in 1980s. How is the period of Digital hearing aids.

AMPLIFICATION SYSTEM - I

1. This is an amplification system or a hearing aid.
2. This is used to amplify the sound signal given to it. It gives the amplified sound as the output to the listener who can thereby overcome the hearing loss and communicate effectively.
3. This can be used by all the hard of hearing individuals irrespective of age, sex, culture. But there are certain "selection criteria" to be followed, before an individual uses it.
4. The different types of hearing aids are Body level; Ear level (spectacle type; behind-the-ear; in-the-ear and in-the-canal or canal hearing aid). We can find both air-conduction and bone-conduction hearing aids in body as well as ear level hearing aids.
5. The accessories required are - ear mold or eartip, cord with 2 pin or 3 pin plug, receiver, tubing (in case of behind-the-ear (BTE), handle or clip (so as to clip the aid on the user) and cells (the type of batteries varies from one hearing aid to another).
6. General requirements: (i) Design: The hearing aid should avoid feedback; should minimize effects due to change in temperature, relative humidity, body perspiration and shocks or mechanical damages, (ii) Power supply: of battery voltage with 1.5 v. and the battery size should conform to R6 size of IS:7218-1974.

Dimensions and mass: (i) The maximum permissible dimension for battery operated hearing aids [Body level]:

Overall height should be 80 mm

Overall width should be 65 mm

(ii) The mass of the aid with mechanical support and excluding hearing aid batteries, cord and ear plug shall not exceed 60 gms.

Controls; Every hearing aid should have controls such as (a) Battery 'ON-OFF' switch; (b) Gain or volume control; (c) Tone selector; (d) Telephone coil (Optional).

Earphone receiver, cord and ear plug: Each hearing aid shall be provided with a receiver of either air-conduction type *or* bone-conduction type. A light weight flexible cord terminated on both ends by means of plugs conforming to IS :3720-1983 and a length of at least 50 cm shall be provided. An ear insert also shall be provided with the hearing aid.

AMPLIFICATION SYSTEM - II

1. Referring to the figure, the basic components of a hearing aid may be named as: (1) On-off switch, (2) Volume control, (3) Tone control, (4) Microphone, (5) Battery compartment, (6) Clip, (7) Cord, (8) Receiver, (9) Earmold.

2. The on-off switch helps as to stop and start the working of the hearing aid. The volume control allows only a certain amount of the amplified sound as the output. This is variable and hence makes the hearing aid more flexible. Tone control allows the amplification of specific frequency signals such as the high, low or normal range frequencies. The microphone picks up acoustic signals from the environment, changes it into the electrical signal. The cells or the batteries are held in the battery compartment of the hearing aid. With the help of the clip, the placement of the aid is more secure. The cord carries the amplified electrical signal from the hearing aid to the receiver. The receiver receives the amplified signal and converts the electrical signal into acoustic signal before delivering it to the listener's ear. The earmold holds the receiver in place and provides a good seal thereby preventing leakage of sound from the receiver and the consequent feedback.
3. (a) The receiver acts like a small speaker which converts the amplified electrical signal into an acoustic signal. The human ears can interpret this sound signal. Hence with the absence of receivers, the

amplified electric signals will not be converted into acoustic signal and fed to the human ear. Further, based on the frequency response and impedance of the receiver, the output from the hearing aid can be modified.

- (b) Microphone is sensitive to sound or acoustic energy. It has the capacity to convert this into electrical energy. This conversion is required as the input has to go next to the amplifier which is an electrical device, so with the absence of a microphone the conversion of energy will not be achieved.
- (c) If the earmold is missing then the receiver will be precariously placed in the ear. Also there will be a loss in the amount of sound energy reaching the ear drum as the receiver simply lodges in the outer ear with minimum acoustic seal. A lot of sound energy leaks out which is picked up by the microphone hence resulting in an acoustic feed back. This further leads to distortion of the sound signal. Thus the sound is not only weak but is also distorted by the time it reaches the ears.
- (d) Battery acts as the "power house" of the hearing aid. So, with out this the hearing aid fails to work.

(e) Without the clip, one will find difficulties in the placement of the body level hearing aid. Clip enables appropriate placement and also enables the microphone to face the sound source. So, without the clip, the user may keep the aid in his pocket thereby covering the microphone,

(f) With a variable volume control, the sound output can be varied by the user. For instance if the input itself is loud, then the user can keep the volume at a lower level so as to prevent damage of the ears due to over amplification. This is useful in such hearing aids which do not have output limiting circuits like MPO,AGC. Variable volume control also enables the user to increase the volume setting when the battery gets weak.

4. An earmold may be replaced by an eartip. But this at best is a temporary alternative. If the clip is missing the user may get a pocket or a harness sticked which is appropriate to the hearing aids sizes. It should be such that it does not cover the microphone and yet holds the aid. The receiver, microphone and the battery cannot be replaced by any other parts. These are the most essential components of a hearing aid.

BLOCK DIAGRAM OF A HEARING AID

1. The battery compartment and the battery are missing.
2. The battery provides power for the hearing aid. The circuit of the aid is completed by this as the negative and positive terminals of the battery will be connected. Once this is done, current flows across thereby allowing the working of the hearing aid.
3. Any hearing aid working requires an voltage of 1.5 volts. This is indicated on the batteries.
4. The different types of cells can be categorized under the following groups:
 - a) Size - Pentorch (used in body level hearing aids)
 - Button (used in BTE, ITE, Canal and spectacle hearing aids) .
 - b) Composition - Mercury, silver oxide, nicad (Nickle-cadmium) zinc air cells.
 - e) Manufacturer's - In India, the pentorch sized cells can be grouped under - Hippo, Novino, Eveready, Toshiba Anand cells.
5. This is placed separately from the printed circuit board (PCB) of the hearing aid so as to avoid the possible damages which may occur due to the leakage of the cells.
6. As it becomes weaker with usage, the amplified sound will be affected. The sound output too becomes weaker as a result of this. This requires an increase in the volume setting of the hearing aid. Even if the required amount

of voltage of the cell is not used, the output is once again affected. As the working of an aid needs 1.5 volts, if *the* cells has an voltage less than 1.5 volts, either the amplified sound will be weak and hence not serve the purpose or the aid may sot work. So, the quality of sound changes due to weak or dead cells, wrong size, wrong placement, leaking cells, dirty or corroded battery contacts. The aid may not produce sound, may produce weak, intermittent or distorted sounds as a result of the poor battery conditions mentioned above.

MICROPHONE:

1. The above drawn figure is that of a directional microphone.
2. Directional microphone is a microphone, the diaphragm of which senses the difference between the air pressure occuring on either of its sides and transduces it to give an electrical output signal.
3. There are two inlets - the front and the rear. These two are separated by thin diaphragm which is sensitive to the pressure difference which impinge on the two surfaces. It moves and converts the input into electrical output. But, if the pressures on both sides are equal then the output gets cancelled.

4.(i) Using this, better signal to noise (S/N) ratio is got.(ii) There is better localization ability in case of BTE hearing aid users. (iii) As it acts like an omnidirectional microphone, the user would find it easier to listen when his/her hearing aid has this microphone.

5. (i) Feedback is got at lower gain levels due to the additional microphone entry. (ii) Likelihood of increased wind noise is more. (iii) The 2nd microphone inlet leads to collection of dust and debris. Hence frequent repairs are needed. (iv) There is a change in quality of sound due to the suppression of sound from rear entry.

CORDS:

1. Cords establish an electrical connection between the hearing aid and the receiver and thus deliver the amplified electric signal to the receiver.
2. (a) Single or 'S' cord; (b) 'Y' cord; (c) 'V' cord.
Cords may be classified under the following categories:
(a) Y, V and S cords; (b) 2, 3 or single pin cords.
Here all the 3 cords are 2 pin cords.

3. Y-Cord

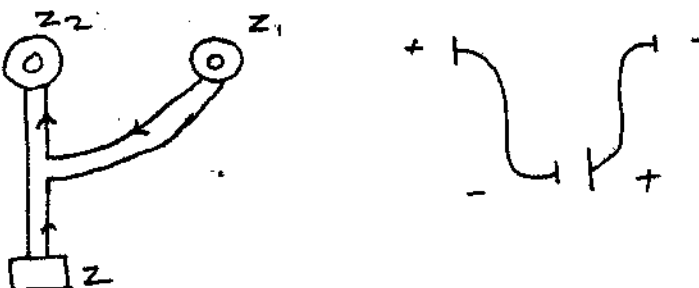

Here, both the receivers are fed by the same wiring connection. The connection is made in series in India. Abroad, it is in parallel. Due to this the total impedance (Z) is the sum of the impedance of both the receivers: $Z=Z_1 + Z_2$

V-cord

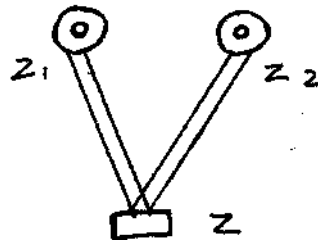

3-pin



The 2 receivers are fed by two different wiring connections, the connection is in parallel in India and series abroad.

So, even if one part of the cord falls to work or if one receiver is removed, the user can continue to use the same cord. The impedance of hearing aid (Z) is gives by

$$Z= \frac{Z_1 Z_2}{Z_1 + Z_2}$$

$$Z_1 Z_2$$

4. Y-cords are used la bilateral symmetrical hearing loss cases.

V-cords are also can be used with bilateral symmetrical loss cases. But if the hearing aid has a provision for maximum power output (MPO) separately for the two receivers then it can be used with asymmetrical less cases too.

S-cords are used when only one ear needs amplification.

It may be when only oae ear is damaged or while prescribing aids to old people who stay indoors most of the time (from economy point of view).

3-pin cords - Earlier these were used in such hearing aids which required large power output. But now-a-days the 2-pin cords are able to replace this also. For eg. Arphi Push-Pull aids.

5. The earmold accessories used along with the cords are

(i) Canal test tips - are soft rubber test tips which use rigid tubing in bead area with 5".flexible tubing attached.



(ii) Half moon couplers - are self threading plastic connectors with a reinforcing metal band so as to prevent splitting. These are used in BIE aids.



(iii) Threaded couplers - are used in BIE aids.

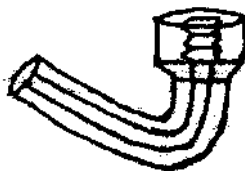

(iv) Elbow fitting - is used to monitor full opening of a bead out of mold and to make quick and easy replacement of tubing.



(v) **Adaptors:**

a) Male adaptors - with this, it is possible to use a regular mold with a BTE aid. The adaptor is fitted to the snap ring of the mold and a length of tubing is attached

between the adapter and the ear hook of the hearing aid.



- b) Female adaptor -with this, it is possible to use a skeletal mold with a body level hearing aid.

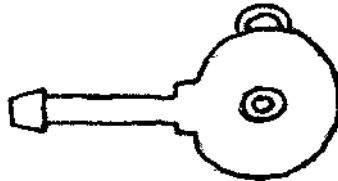

6. the cords should be - light weighted, -terminated at both the ends by means of plugs confining to IS:3720-1983,
 - The length of the cord should be atleast 50 cm.
- f.(a) The cords should not be knotted and twisted,
 (b) User should make sure the right pin is plugged into the right hole.
 (c) The user should not let the cords dangle when he/she wears the hearing aid.
 It should either be put late the pocket or the dress.
 (d) At the same tine user should make sure that the cord is not under tension.
 (e) When not under usage, the cord shou/ld not be wound tightly around (the hearing aid) neither should it be left loose.
 (f) It should be kept in a place which is free of insists, rats, etc. which may chew off the cord.

- (g) It should be kept away from children's reach. And if a child is to use it, then the child should be made to understand that the cord is not meant to be played or meddled with.
- (h) The user should not use sharp things to clean the cord as it may result in cutting off the cord.
- (i) The cord should be washed with water and dried immediately.
- (j) The cord should not be exposed to heat as it may crack.

EARMOLDS:

1. Earmold is a plastic or silicone insert designed to conduct the amplified sound from the hearing aid receiver into the ear canal. It has other names such as - earpiece, acoustic modifier, discriminator, word separator, clarifier, according to various manufacturers.
2. (1) It keeps the hearing aid (in case of BTE) or the receiver (in case of body level) in place. (ii) By occluding the external ear (at various extents) it provides an acoustic seal to the sound fed into the ear through the receiver. (iii) It thereby acts as a conveyor of sound from the receiver to the ear. (iv) It also acts as an acoustic modifier.

3. Earmolds can be classified into many types under the following categories.

- a) Physical style - regular, shell ($\frac{3}{4}$ and $\frac{1}{2}$), skeletal ($\frac{3}{4}$ and $\frac{1}{2}$) and canal ($\frac{1}{3}$ rim and $\frac{2}{3}$ rim).
- b) Non-occluding - no mold (only tubing). Free field or open and Janssen.
- c) Antifeedback - power, tragus and macrae.
- d) Acoustic - molds which have vents, dampers endhorns.

4.(i) Venting - which is the second channel so as to attenuate low frequencies. The vent may be parallel or diagonal to the sound channel. Or it may be external venting.

(ii) Dampers - This is used for aid frequency amplification control (750 Hz - 3 KHz). The damping elements such as cotton, fine plastic mesh, porous stainless steel plate, sintered filters (tiny stainless steel cylinders that are welded) are placed either in the vents or the sound channel. These smoothen the sharp primary peak of the hearing aid response curve.

(iii) Horns - These increase the high frequencies. The modifications are done only in the sound channel by changing the diameter of the sound bore, Narrower the sound bore, greater the high frequency modification. The three

types of horns are - Killion, Bakke and Libby.

(iv) Earmold adjustments - By shortening and tapering the canal, removing the helix or decreasing the concha and tragus areas.

5. Metal or plastic rings - to give extra grip to the receivers. Tubing - to couple the, BIE to the molds. It may be straight or pre-bent. Connectors or angle pieces -used of the tubing is not pre-bent. Male and female adaptors.

6. Body level - regular, all antifeedback molds.

BIE - shell, skeletal, all antifeedback.molds.

Spectacle - shell, skeletal, all non-occluding molds.

ITS and canal - modulated (or ITE shells) molds.

7. (i) Do not drop or throw the molds

(ii) Do not keep detaching the receiver from the mold as the ring may become loose.

(iii) Do not use sharp things to clean in ease of soft and composite ear molds.

(iv) Also do not give them to children as they tend to pluck off the soft parts of the mold.

(v) They should not be placed where there may be insects or other beings Which may chew off the soft parts.

- (vi) Do clean the mold with luke wamrwater so as to remove the wax and dust.
- (vii) Dry the mold soon after cleaning.
- (viii) Use the right mold to the corresponding ear and person.

TYPES OF AMPLIFICATION SYSTEMS-

1. These are sir conduction heating aids.

- (i) Is a body level hearing aid
- (ii) Ear level
 - (a) Behind the ear (BTE);
 - (b) Spec table hearing aid.

2.

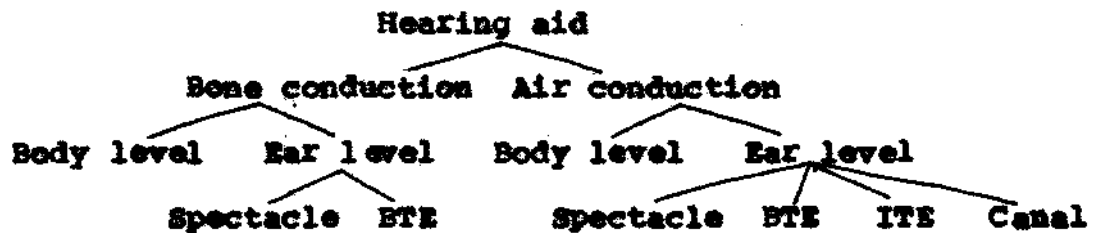

3. Some of the important factors include:

- a) Age of the user - for instance, body level hearing aid is preferred for infants, and old people.
- b) Cosmetic appeal - if the user wants the equipment to be inconspicuous, then either BTE or ITE recrecommended.
- e) Environment where the aid is used - for example, if the hearing aid needs to be used where electro-magnetic signals ace present, an aid with telecoil should be given to the user.

d) Discharging ear - requires amplification through bone conduction hearing aids.

4.

	Body level	BTE	Spectacle	1*1	Canal
Microphone placement	Top of front	Top & bottom	Side or front	In the concha	In the canal
Gain of the aid	upto 70 dB	65 dB (some)	Till 65 dB	Upto 45 dB	25 dB
Acoustic feedback	No feedback	May be present	Feedback is more when the microphone is, at side	Possibilities are more as microphone-receiver distance ↓	Possibilities are more as microphone-receiver distance ↓
Provision for CROS	Not possible	Possible	Possible	Not possible	
Provision for directional microphone	Not possible	Always present	Some may have	May be present in large aids	Not possible

5. Hearing aids can be classified based on (a) Mode of transmission: Air-conduction and bone-conduction.

b) Placement - Body level, spectacle, BTE, ITE, canal,

e) Gain and SSPL 90

Gain (i) Full on - {Mild (45 dB)
Moderate (55 dB)
Strong (65 dB)
Mild(40 dB)

(ii) HEA full on {Moderate (50dB)
Strong (60 dB)

Mild (115 dB)
 SSPL 90- { Moderate (125 dB)
 strong (135 dB)

- 6.(a) Body level hearing aids are prescribed for young children and the elderly eases. Similarly for the multiply handicapped, it is best to recommend a body level hearing aid as the controls are big and easy to manipulate. Where as the spectacle, BTE and ITE hearing aids may be preferred for cosmetic purposes.
- (b) When more amplification is required, it is best to use body level hearing aids. And for better localization abilities, the ear level hearing aid selection will be a good choice.
- (e) From financial point of view, the body level hearing aids are inexpensive and so are the further maintenance costs too.
- (d) As the body level hearing aids are more sturdy, long lasting and fit more steadily these aids are preferred when the user is a very active person and needs to do a lot of running around.
- (e) Body level hearing aids are recommended when the amplified sound needs to be modified repeatedly, this can be achieved by modifying the molds, receivers, control settings and microphones.

- (f) Spectacle hearing aids may be used when it has to serve dual purposes; namely visual correction and auditory rehabilitation.
- (g) The provision of having contra-lateral routing of signal (CROS) only in the BTE and spectacle hearing aids has made it possible to compensate for, the hearing loss in the poor ear even when the hearing in the other ear is within normal limits.

TYPES OF AMPLIFICATION SYSTEMS- II

1. This is a spectacle aid with contra lateral routing of signals (CROS}. It is called so because the signal which is picked up on one side or ear is fed to the other side or ear via a wiring called as cross wire. The sound is amplified and fed to the better ear. So we see routing of signal from the opposite or contra-lateral ear.
2. CROS can be provided only in the BTE and spectacle hearing aids.
- 3.(i) There is increased ease in hearing speakers from the side of the poor ear. This is due to the elimination of head shadow. (ii) Using this, we find an improvement in auditory localisation ability. The user utilises the difference in quality between sounds entering the better ear naturally and CROS- amplified sounds.

(iii) This system also enables the user to listen better in noisy environments. The phenomenon of squelch effect is used here.

4. Classic CROS, high CROS, mini CROS, focal CROS, power CROS, Bi-CROS, Open CROS, uni CROS, multi CROS, Cris-CROS, IROS, FROS, Bi FROS, Double FROS and Bi FROS 270.
5. (i) Before fitting the aid, medical clearance should be obtained: especially in case of unilateral loss. (ii) Final decision regarding a CROS should be done only after a trial period of at least 3 or 4 weeks. (iii) It is important to find the communication demands placed on the patient's hearing and his communication needs. (iv) The status of hearing in the better/^{ear}should be determined as, the better the hearing, the less the chances are for successful CROS use. (v) Patient's motivational level is to be considered. If he is highly motivated, it is more likely that CROS will benefit him well.

TYPES OF AMPLIFICATION SYSTEMS- III

1. The amplifying system shown above is a cochlear implant.
2. The components are: (1) Transmitter (2) Receiver (3) Microphone (4) Processor.

3. The advantages include:

- (i) It supplements lip-reading by giving auditory cues.
- (ii) Gives information regarding timing - intensity of speech and limited pitch information.
- (iii) Using this, there is an improved ability to monitor speech.
- (iv) There is an improved awareness of suprasegmental features of speech.
- (v) Using this, there is a better recognition of everyday sounds.
- (vi) Users find they have lesser head noise or tinnitus.

4. The disadvantages are:

- a) Due to the electrical stimulation, there can be a new bone growth or ossification as a result of the histopathological changes.
- b) Post-operative complications may arise such as -facial paralysis, intra or extra cochlear infections, mechanical rupture of basilar membrane, reissner's membrane and spiral lamina (This in-turn increases the neural degeneration of cochlea).
- c) The sound through a cochlear implant is not natural and clear enough. It sounds mechanical.
- d) Learning to use this device is a long process. Hence time is lost.

- e) Users cannot comprehend what speakers are saying without looking at the speaker's face.
- f) The users cannot use telephones.
- g) They fail to hear the rhythm of music which they hear it as a jumble of noises.
- h) They also fail to localize the sound source.

5.

- a) This is implanted only on the profoundly deaf population,
- b) A majority of the nerve fibres need to be intact. This condition can be found by either polytone x-ray or nuclear magnetic resonance (NMR) and there should not be a cochlear ossification.
- e) This is recommended only if hearing aids are found to be of no use.
- d) The otological condition should be good.
- e) General health should be good.
- f) The age of the patient should be at least 13 years.
- g) The ear with poorest responses is chosen for surgery.
- h) As better results are got if the onset of deafness is late, it is preferred in cases with post lingual deafness than in congenitally deaf individuals.
- i) Psychological and speech-language evaluations are to be done.

TYPES OF AMPLIFICATION SYSTEMS-IV

1. This is a hand-held battery operated programmer (for the Quattro hearing system).
2. This instrument is used to transmit wireless coded radio frequency signals that change the analog responses of the hearing instrument.
3. The keys - 1, 2, 3 and 4 are the response keys which immediately activate a different electroacoustic response for the hearing instrument when pressed. 'M' is the microphone key. 'T' is the telecoil key used when the information is given through telephone. The keys with sign - V and Δ are the volume control keys of the output intensity.
4. These BTES have to receive radio frequency signals from the programmer. They should be constructed on the basis of digitally controlled, analog amplifier and should have a control register that accepted the wireless transmission of a coded radio signal and allows the instrument to respond appropriately.
5. Some of the advantages include:
 - i) There is no hard wire connection between the hearing instrument and the programmer.
 - ii) The wearer and the dispenser can change the output function whenever needed.

- iii) Programming key allows dispenser to sit anywhere within 6 feet of the user and change the output response by remote control.
- iv) The user can hold the remote in hand, unnoticed and select the response which is best in that specific environment.

ELECTROACOUSTIC . CHARACTERISTICS - I

1. This hearing aid lacks in it's circuit, the components needed for output compression or limiting.
2. (i) Peak clipping and (ii) Automatic gain control or automatic variable control[AGC or AVC].

The second method ie AGC/AVC is preferred due to its advantages such as:

- a) Little distortion, (b) Output limited to a level below saturation through gain reduction to the entire signal.
- e) This inturn expands the wearer's dynamic range by providing wider range of input levels to the ear and yet they do not exceed tolerance limits of the ear. (d) The original S/N ratio of input signal is maintained here, unlike tn peak clipping. some disadvantages of peak clipping are: (1) It introduces harmonic distortion and hence a possible decrease in speech intelligibility.

(B) There is a great reduction in the sound quality itself. (3) S/N ratio of the output decreases very much as a result of the process of clipping.

3. Saturation sound pressure level.

4. (i) Limiting level (ii) attack time (iii) release time (iv) compression ratio.

5.

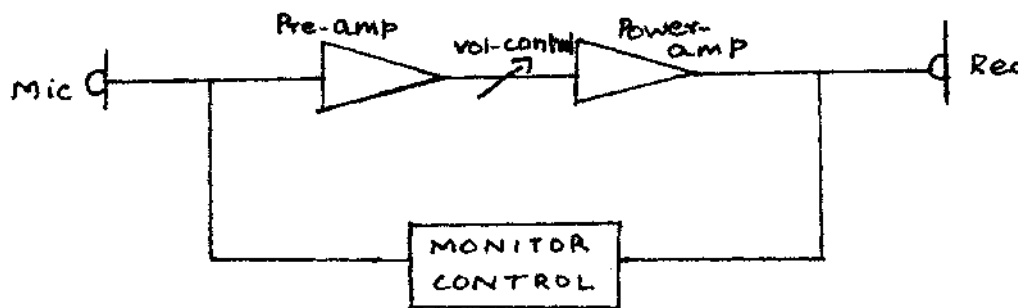

ELECTROACOUSTIC CHARACTERISTICS - II

1. Knowles Electronic Manikin for Acoustic Research.
2. Using KEMAR, we can observe the effects of body and head diffraction on an acoustic signal. This manikin is preferred due to the following advantages. (i) It is a reproducible test subject that allows uniformity between laboratories (ii) It can be kept stationary for testing over a long period of time, (iii) The manikin does not show response changes as a result of fatigue or other physiologic or psychologic changes.

3. It consists of a head and torso and has the dimensions of an average human adult including pinnae and ear canals.
4. It is used to make electroacoustic measurements such as SSPL-90, Reference threshold gain, frequency response, battery drain response and equivalent input noise level.
5. There are no models that are similar to KEMAR in terms of the dimensions and physical appearance (ie manikin). However in some researches KEMAR may be substituted by Zwislocki 2 cc coupler. Also, researcher B.Lindstrom has used a Neumann Artificial Head in his study. It employs two 7/8" condenser microphones located in the ear canal. In front of the membrane, there is a cavity that approximates the acoustic impedance of the average human ear. The head is further delivered with a torso.

ELECTROACOUSTIC CHARACTERISTICS - III

1. This graph represents an electro acoustic characteristic called as SSPL-90 ie. saturated sound pressure level. It is the S.P.L. developed in a 2 cm³ ear coupler when the input SPL is 90 dB with the gain control of the aid in full-on.

X-axis is frequencies in HZ, and Y-axis is intensity in dB.

2. Electroacoustic measurements are needed:

- i) To check if the hearing aid is within the standard limits.
- ii) To find the quality of the hearing aid.
- iii) So as to help in research work which requires precise/ accurate values. These values can be got only with electroacoustic measures.
- iv) So as to check the aid after repairs.
- v) To compare 2 or store hearing aids.

3.a) H.F.A SSPL - Average of 1 KHz, 1.6 KHz, and 2.5 KHz values of SSPL-90. It is the acronym for high frequency average saturation sound pressure level.

b) Gain - The amount of dB by which the SPL developed by the receiver exceeds that developed in a free field at the face of the Microphone.

c) RTG (or Reference Test gain) - is an Electroacoustic Characteristic which is established using an input SPL of 60 dB, by adjusting the gain control so that the average of 1 KHz, 1.6 KHz and 2.5 KHz gain values are equal to HPA SSPL-90-17 + 1 dB.

d) Frequency response - is the response got across various frequencies with the gain control in the reference test position and with an input sound pressure level of 60 dB.

e) Harmonic distortion - results when new frequencies are generated that are whole number multiples of the original or fundamental frequency, and that are not part of the input signal.

- f) Equivalent input noise level (L_n) - is the internal noise of the hearing aid even when it is switched off.
- g) Effect of battery drain - on working of the hearing aid.

44. Environmental tests -

- i) Humidity - (a) Dry heat (b) Damp heat.
- ii) Temperature
- iii) Atmospheric pressure
- iv) Vibration test (in magnetic field set up)
- v) Impact
- vi) Bump.

5.(i) Acoustic feedback - which is because of-poor receiver and earmold coupling.

- Broken or cracked earmolds.

These are referred to as direct leakage. It is overcome by using plastic washers so as to bring about good contacts between the earmold end receiver, rubbing vaseline to decrease the squeal as a result of improper mold fitting; replacing the cracked mould by a new mold.

- Poor isolation of microphone and receiver which is referred to as indirect leakage. This is overcome by increasing the distance between the two or placing a rubber tube at the microphone opening.

- (ii) Mechanical feedback - as a result of wearing-off of the rubber cushions which the hearing aid components may be mounted. So as to prevent this, the old rubber cushions may be replaced or, the microphone and receiver can be mounted perpendicular to each other to dampen the total vibrations,
- (iii) Magnetic feed back - results from the coupling between the magnetic fields of the receiver and the telephone coil or magnetic microphone. The magnetic field from the receiver can spill over to the microphone or telecoil. This can be reduced by using non-magnetic microphones and improved receiver designs.
- (iv) Electronic feed back - There are two forms: (a) Electrostatic feed back which is caused by a capacitive coupling from the output to the input stages of the amplifier. It sounds like a hiss. (b) Electrical oscillation which results from inadequate decoupling of battery and amplifier circuits. As battery voltage decreases, impedance increases and causes the amplifier circuit to oscillate. A sound like that of a low frequency motor boating is produced. It may be stopped by changing the battery and improving decoupling and also making the circuit impervious to battery voltage changes.

6. By changing the earmold characteristics, the SSPL curve can be modified. For eg. if the earmold has venting, SSPL-90 has to be lowered so as to prevent the feedback which may be produced indirectly.
7. (i) Loudness based measurements - The principle of this technique to ensure maximum output level is high enough to avoid limiting the speech signal when the user is listening at his/her preferred listening level.
 (ii) Threshold based measurements - Principle is to protect the user from potentially intolerable output levels from the aid. Hence it does not exceed loudness discomfort level.
 (iii) SSPL 90 curve may be obtained either by real ear or by coupler measurements.
3. More than one recording can be got on the same graph. This is required when one has to compare the electro-acoustic measurements of two or more hearing aids and earmolds.

AUDIOGRAM AND AMPLIFICATION. I

1. "TACTILE".
2. Can be recommended to (a) hearing loss cases with persistent ear discharge. (b) Atresia and other congenital

malformations of the external ear.

3. (i) As the temporal structure is got from frequencies till 1 KHz, we can perceive voicing information (200-300 Ms) and the first formants.
 - (ii) This enables us to perceive and track speech rhythm.
 - (iii) The tactile sense helps us to identify the environmental sounds due to the characteristic rhythm and low frequency elements.
 - (iv) It is helpful in controlling the wearer's speech rhythm - loudness and pronunciation.

4. (i) It does not have cosmetic appeal
 - (ii) Its size and weight come in the way of the user's comfort.
 - (iii) It cannot be used in noisy environment.
 - (iv) It requires more power to bring about the tactile sense in the user.
 - (v) It cannot be used for frequencies above 1 KHz.

5. In this type of amplification system, the signals are fed to the user via tactile sensation instead of the auditory mode. The user perceives the vibration from sounds. The tactile sense gathers information about sound signals by recognising certain features. This tactile aid is only a temporal analyser. The frequency components are perceived indirectly as a result of changes in the temporal properties. This cannot be used for frequencies above 1 KHz.

6. The vibrator can be placed either on the wrist, behind the ear or tied around the waist.

AUDIOGRAM AND AMPLIFICATION - II

1. Bone conduction hearing aids, and CROS hearing aids.
2. These hearing aids do not require the placement of earmold in the poor ear or the discharging ear. In case of BC hearing aid, the signals are fed into the ear via bone conduction by placing the BC-vibrator behind the ear. In case of the CROS hearing aid, the signals on the poor-ear side is picked up by a Microphone on that side and the amplified signal is given to the better ear.
3. Amplifying a conductive loss case is different from that of sensori-neural hearing loss case in the following ways:
 - (i) Gain - half gain rule of amplification can be used in case of sensori-neural(SN) hearing loss. Eg. 50 dB loss improves with 25 dB average use gain. However in conductive loss cases the use gain corresponds to 90% - 100% of the hearing loss.
 - (ii) Saturation and SPL - This is greater for conductive loss cases as these patients have larger dynamic range than the SN hearing loss cases.

- (iii) Frequency response and range - need to be greater for conductive losses.
 - (iv) Earmolds - as high gain is required to amplify conductive loss, well fitting molds with no venting is recommended unlike in case of SN hearing loss cases where venting is preferred.
 - (v) Acceptance of hearing aids - usually easier with conductive hearing loss accept faster than those with SN hearing loss.
4. (i) Amplification is suggested when medical intervention is not possible (when the patient has high blood pressure, active infection in the ear or other active diseases which may decrease the general health).
- (ii) When there is no improvement in the hearing ability in spite of surgery.
- (iii) If the patient has Mixed loss (because even with surgery, the condition does not get better).
- (iv) When the patient himself does not wish to undergo the surgery.
5. Individuals with conductive hearing loss have greater communication problems than SN hearing loss with recruitment. This is due to the difference in loudness at comparable sensation levels. The former group hears only at 10 dB SL. So the latter group tends to do better without rather than with amplification.

AUDIOGRAM AND AMPLIFICATION - III

1. It is preferred to amplify the low frequency signals.
2. Auditory and vibro-tactile.
3. Frequency transposition is the shifting or coding of speech in such a way that high frequency sounds are represented in the auditory range of ears with low frequency residual hearing.
4. For this left-cornered hearing loss case, the speech information of high frequencies is transposed to low frequency so as to make it audible. The transposed signals are superimposed on the conventionally amplified sound to create a new sound pattern. This may be represented as follows:

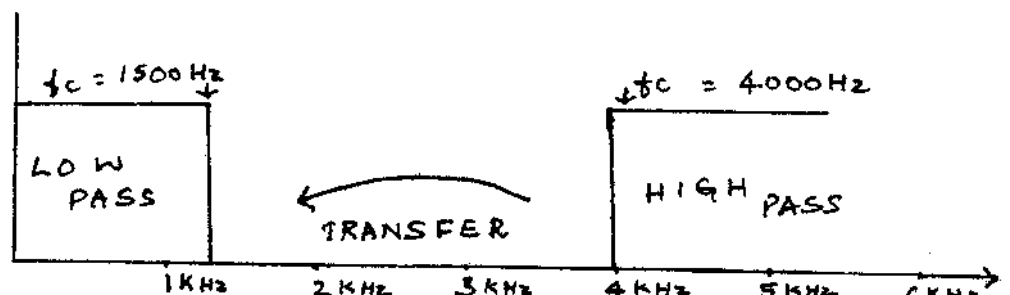

- 5.(1) Due to the low frequency emphasis, there is an upward spread of masking effect that decreases the speech discrimination ability. (ii) This phenomenon also causes tolerance problem. (iii) The users complain of distortion of the amplified signals.

AUDIOGRAM AND AMPLIFICATION - IV

1. Amplification is not suggested at this stage.

2. Contra lateral routing of signals.
3. Open molds are found to be useful; if not vented molds or molds with dampers. These molds bring about better high frequency amplification.
4. In such a case, the right ear is preferred to be amplified. It follows the criteria; if the loss in the better ear is better than 60 dB, the poorer ear is fitted with amplification system.

AUDIOGRAM AND AMPLIFICATION - V

1. Body level hearing aids; and high CROS hearing aids.
2. These hearing aids are selected because they give high frequency emphasis and these can be used in bilateral cases.
3. Yes. Earmolds that have vents or dampers so as to result in high frequency emphasis. Non-occluding molds are used when CROS hearing aids are recommended.

A STEP IN REHABILITATION PROCEDURE:

1. This figure shows the placement of a cotton plug in the ear canal in the process of taking an ear impression. Cotton needs to be placed so as to prevent tapering of the impression material into the ear. So the cotton plug offers resistance to the material.

2. Otoscope, cotton-string, earlight (to push cotton in) syringe or paper cone, scissors, cap or lid (to hold the impression material in place in the ear).

3. Three types of molds can be got using different Materials. They are hard, soft and composite molds. Materials for Hard molds - Acrylic and Lucite.

Soft molds - PVC (Polyvinyl chloride) for tubing
Polythene and Silicon rubber.

There are instant materials. But these are exothermic and also expensive. Cold cure acrylic is one such instant material.

4. (i) Venting can be done. (ii) Placing acoustic foam in the vent to solve the feedback problem, (iii) Decreasing the diameter of the canal or tapering the edges of the canal to get a deep, comfortable fit. (iv) Only the canal tip can be tapered to decrease low frequency and barrel effect. (v) Length of the canal can be changed, (vi) The occluding area two can be taken care of. (vii) Colouring of the earmold - to colourless or cloudy or pink or light-dark brown, (viii) Trimming excess material from the canal tip.

5. Hard mold

Soft mold

Advantages

Gives good support to the receiver of the hearing aid.

Flexible and elastic due to which it can adapt to all movements of the ear canal and can fit well.

Has low specific gravity.

Disadvantages:

There is a foreign body sensation in the ear.

Warm and humid air gets trapped in the area between earmold and ear drum.

Highly polished earmolds slip out of position during chewing and speaking movements.

In powerful hearing aids chances of feedback are more.

ASSESSMENT PROCEDURE

1. The picture shows the process of selection of hearing aids.
2. (i) Prescriptive techniques based on thresholds, most comfortable level (MCL) and bisection of range between the threshold and un-comfortable level.
 - (ii) Comparative or selective techniques based on speech reception - discrimination abilities.
 - (iii) Combined technique - a combination of prescriptive and selective techniques.
3. (i) Degree and type of hearing loss, (ii) Amount of distortion in the hearing aid. (iii) Tolerance levels and the dynamic range. (iv) The environment in which the user lives or works, (v) Motivation and attitude of the user, (vi) Medical problems that contra indicate or indicate temporary use of the hearing aid. (vii) Communicative demands.

4. Procedures vary across age depending on the factors:

(i) Language level - in children as the vocabulary is comparatively lesser than adults, pictures may be used for evaluation.

(ii) Ability to concentrate on the same task. The tester can evaluate over a long period of time in case of adults as they will be in a position to continue the same task for a lengthy duration unlike children who may lose interest after some time.

(iii) Instructions - The procedure should involve simple instructions in case of children, so complex techniques are not used with this group of population.

(iv) Physical properties of pediatric ears - soft molds are needed for the tender ears.

The variation in procedures can be seen in the following illustration:

<u>Age</u>	<u>Technique</u>
Less than 9 months	Observation of the child
0 - 4 years	Sound effect recognition test, behavioural observation.
Less than 3-4 years	Tangible reinforcement operant conditioning audiometry
More than 3 years	Visual reinforcement audiometry.
4-6 years	Word intelligibility picture identification, NU - 6

6-12 years

PBK.

5. Air-conduction and bone-conduction thresholds speech tests un-comfortable level, acoustic reflex threshold, tympanometry.
6. (i) About the hearing aid and the accessories Which have been prescribed to the user (use and maintenance), (ii) the use of amplification (iii) The hazards of over-amplification and how it can be prevented. (iv) How he can modify the listening situation (for eg. Asking the speaker to speak slowly and enabling him to lip read the speaker asking the speaker to paraphrase if he fails to understand, reducing the extra noise such as radio and television While he is listening to others) • (v) The use of assistive listening devices.

MODES OF AMPLIFICATION

1. Figure-A represents monaural listening condition while Figure-B binaural listening condition.

<p>2. <u>Monaural</u></p> <p>Does not provide too much sound; hence is useful in cases with tolerance problem. Enhances localization. Easy to manipulate due to lesser number of controls. Maintenance costs are lesser.</p>	<p style="text-align: right;"><u>Binaural</u></p> <p>It has the ability to squelch the background noises. Enhances localization. Using this there is a summation of energy at threshold and supra threshold levels. Overcomes head shadow effect. Better discrimination of speech. There is an ease of listening. Better sound quality and spatial balance.</p>
---	--

MonoauralBinaural

3.(1) User fails to get any clues about localization of sound.

(ii) With amplification being given to only one ear, the other ear may become a dead ear (if user fails to use alternately)

(iii) It lacks all the points mentioned as the merits of binaural listening conditions.

(i) User takes longer time to get adjusted to the hearing aids as compared to monoaural listening condition.

(ii) Is cumbersome as it involves manipulation of too many controls.

4. Pseudobinaural hearing.

Here the amplified signal is carried to the ears through a 'Y' cord. So, it is used with binaural symmetrical hearing loss cases. Both ears get the equal amount of signal. It is not considered as a binaural condition because the amplified signal is collected through only one cord from the hearing aid. This single cord then splits so as to give the output to the 2 ears.

5.a) Decrease the volume in this condition as compared to monoaural. This is because, the binaural summation results in a gain of 3 dB.

b) Do not change the hearing aids especially in case of asymmetrical hearing losses.

e) Keep both the hearing aids at the same level. Usually they are separated by a distance of 6-8".

d) Set the volume controls of the two hearing aids such that both ears receive the signals at the same loudness level.

- e) The cords should not be criss-crossed. That is, the right ear cord should be connected to the right hearing aid and the left ear cord to left hearing aid.
6. All groups of subjects with binaural hearing impairment (symmetrical or asymmetrical) do better with two hearing aids than one. However subjects with symmetrical hearing loss get significant hearing advantages in terms of speech discrimination and localisation enhancement from binaural hearing aids.

If a person with binaural hearing loss can accept speech delivered through hearing aids at an intensity level which is at least 20 dB above his speech detectability threshold at each ear, then such a person will get maximal benefit from Binaural amplification.

HEARING AID MAINTENANCE

1. a) Battery tester/voltmeter; (b) Forced air earmold cleaner; (c) Toothbrush and soft brush/ (d) Magnifying glass; (e) Alcohol and cotton swab? (f) Hearing aid stethoscope and adapter; (g) Pipe cleaners.

2. Battery tester: Is used to ascertain if a cell has the voltage needed for a particular hearing aid.

Forced air earmold cleaner - Is used to remove moisture from the earmold and the tubings after they have been

washed. One can also find if there are any obstacles in the passage of sound.

Toothbrush and soft brush - While the former is used in washing of an earmold, the latter is used in cleaning dust from the switches and the microphone.

Magnifying glass - To get a clear and better look of the tiny parts of the hearing aid. Is especially useful with FCBs.

Alcohol - Used to clean the battery contacts when corrosion occurs.

Stethoscope and adaptor - Enables one to listen only to the amplified sounds of the/aid as both ears of the listener are occluded.

Pipe cleaners - Is used to remove wax from earmolds.

6. One can find these materials in a hearing aid maintenance kit.
4. Hearing aid maintenance program needs to be carried out so as to ensure continued maximum performance of a hearing aid. The causes of the malfunction can be identified easily and quickly, at times may also be resolved.
5. It may be done under two categories: (a) Daily visual inspection and listening check (of the battery, earmold, tubing, receiver, cord, switches and the hearing aid case).

(b) Periodic electroacoustic measurements - usually the user is suggested to get his/her hearing aid thoroughly checked once in six months. This is especially in case of young-school going children.

ASSISTIVE LISTENING DEVICES

1. Tills is a silent-page alerting system.
2. It is a battery operated system used for the hearing impaired persons. It has a sensory transmitter which is placed near the sound source and a receiver that is worn on the hand of hearing individual's wrist. The transmitter sends a radio signal to the receiver which vibrates. The user identifies the sound source by means of a coded light.
3. Some of the advantages include:
 - (i) It is wireless, hence it can be used anywhere in a residence;
 - (ii) it is light weight;
 - (iii) it is portable.
4. ALD is a hearing device that helps a person in varied environments to improve his/her hearing ability. ALDs are used along with the hearing aids. It however may be used even by the normal population, people with mild losses, with severe speech comprehension problem, with tolerance problem.

5. (i) Alerting devices and systems, (ii) Auditory trainers/ personal frequency modulator systems. (iii) Direct-audio-input hearing aids/systems. (iv) Personal amplifiers, (v) Public address type assistive listening system (vi) TDD or TTY systems, (vii) Telecaption decoders (viii) Telephone amplifying devices (ix) Television listening systems or devices (x) Vibrotactile aids and devices.

Frequency modular hearing aids are commonly and preferably used in classroom amplification.

Infra-red systems are used for large area amplification.

Hardwire systems which are one of the oldest types of ALDs are used for interpersonal communication at small gatherings.

Induction loops however are used in big auditoriums.

Telephone aids which may be inserted between the handset and base is used either with aided or unaided ears.

ERA IN HEARING INSTRUMENTS - II

1. The hearing instrument being discussed here is a digital hearing aid.
2. (i) It demonstrates flatter and broader frequency response, (ii) It has a broader dynamic range, (iii) It has better S/N ratio by reducing the background noise (iv) Also, it has lower harmonic distortion.

3. The digital processor is like a computer chip. It acts as an amplifier and converts information into binary digits. Using this component precise tuning can be done.
- 4.(i) Large amount of power is needed for the digital signal processing of signals. (ii) Continuing need for circuit miniaturization is a problem with this.

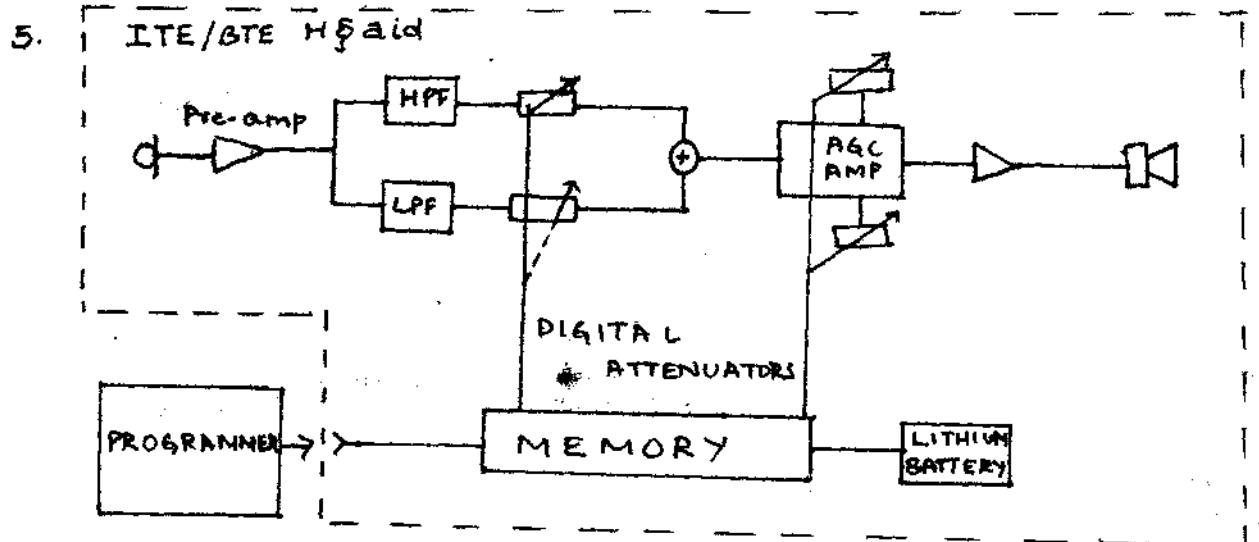

BIBLIOGRAPHY

- Buerkli, O.N. (1987): "The directional Microphone advantage". Hearing Instruments, 38, 8, 34-38.
- Burris, P.D.(1989)x "Getting back to the basis: Post-fitting problem solving". Hearing instruments, 40, 1, 8-13.
- Campos, C.T.(1985): "Cochlear implants: responsibility, challenge, opportunity", Hearing instruments, 36, 6, 6-7.
- Cox, R.M. (1985) : "The structured approach to hearing aid selection". Ear and Hearing, 6, 5, 226-232.
- Dreve Otoplastik GmbH, "Product catalogue", West Germany.
- Frisch-Labor Systems, Product catalogue, West Germany (i) Contact earmold with its impression, (ii) Frissosil silicone impression material.
- Harford, S., Leijon. A., and Liden, G.(1983) : "A simplified real ear technique for verifying the maximum output of a hearing aid". Ear and Hearing, 4, 3, 130-135.
- Hodgson, E. and Skinner, MW (1981)i "Hearing assessment and use in audlologlcal habilitation" 2nd. Edn. Chap.2, Development of the hearing aid industry, 7-18, Baltimore, Williams and Wilkins.
- Hodgson and Skinner, M.W.(1981): "Hearing assessment and use in audiological habllitaton" (2nd edn), Chap-3, Physical characteristics of hearing aid, 19-42, Williams and Wilkins, Baltimore.
- Hodgson and Skinner, MW. (1981): "Hearing assessment and use in audiological habilitation (2nd ed). *Chap -4*, Electroacoustic characteristics of hearing aids, 44-71, Williams and Wkins, Baltimore.
- Hodgson and Skinner, M.W.(1981): "Hearing assessment and use in audiological "habllitation" (2nd Edn.) *Chap.5*, Earmolds, 73-114, Williams and Wilkins, Baltimore.
- Indu, V.(1989): "Assistive listening devices for the deaf; A review". An Independent Project submitted as a part of fulfilment of M.Sc., (Speech and Hearing) to the University of Mysore.

(ii)

- Jyothi, N.(1989): "Earmolds: A review of literature". Independent project submitted as a part of fulfilment of M.Sc.,(Speech and Hearing) to the University of Mysore.
- Keith, R.W.(1980): "Audiology for the Physician"(Ed.) Chap.11, Hearing aids (Rosser, R.J. and I.J.Gerling), 239, Williams and Wilkins, Baltimore.
- Keith, R.W.(1980): "Audiology for the physician" Chap.12. Habilitation of hearing impaired children (Agnes Ling Philips) 267, Williams and Wilkins.
- Loanenbruck and Madele (1981): "Hearing aid dispensing for audiologists: A guide for clinical service" Chap. Business aspects of hearing aid dispensing, 31.63, Grune and Stratton, New York.
- Loanenbruck and Madele (1981): "Hearing aid dispensing for audiologists A guide for clinical service" Chap. Technical aspects of hearing aid dispensing, 63-108, Grune and Stratton, Hew York.
- Loanenbruck and Madele (1981) : "Hearing aid dispensing for audiologists A guide for clinical service". Chap. Clinical aspects of hearing aid dispensing, 109-132,Grune and Stratton, New York.
- Lundborg, T., Sward, T., Lindsterm, B. (1990): "Experiences with classic CROS hearing aids in unilateral deafness" Chap. Earmolds and associated problems, 242-254.
- Markides, A. (1977): "Binaural hearing aids", Chap.1 Advantages of Binaural over monoaural hearing, 1-14, Academic Press, London.
- Markides, A. (1977) :"Binaural hearing aids- Chap-2. Binaural hearing aids, 15-28, Academic Press, London.
- Markides, A. (1977): "Blnaural hearing aids"Chap.10, Main summary, discussion and conclusion,190-209, Academic Press,London.
- Oliveira, J., Kriewall, J., Bantli and Hovort, C.V. (1985): The 3M cochlear implant systems or house design. Hearing instruments, 36, 6, 11-25.

(iii)

- Pehringer, J.L. (1986): "Insights into the application and marketing of ALDS". Hearing Instruments, 37, 7, 46-50.
- Pollack, M.C.(1980):"Amplification for the hearing impaired" (2nd ed). Chap-1 - History and development of hearing aids (Kenneth Berger), 1-17, Grune and Stratton, New York.
- Pollack, M.C. (1980) :Amplification for the hearing impaired" (2nd ed) Chap-2 - Electroacoustic characteristics (Pollack, M.C), 21-86, Grune and Stratton, New York.
- Pollack, M.C.(1980): "Amplification for the hearing impaired " (2nd ed) .Chap- 3, Earmold technology and acoustics, (Pollack, M.C. and Morgan, R), 91-140, Grune and stratton. New Jersey.
- Pollack, M.C.(1980): "Amplification for the hearing impaired" (2nd ed). Chapt-7, special applications of amplification (Pollack, M.C.), 225-300.
- Pollack, M.C.(1987): "Contemporary and future output limiting and noise deduction systems". The Hearing Journal, 40, 3, 22-29.
- Roeser and Downs (1981): "Auditory disorders in school children: Law identification, remediation". Chap-13, Maintenance of personal hearing aids (Musket, C.H.) 229, Thieme Stratton, New York.
- Roeser and Downs (1981): "Auditory disorders in school children, Law identification, remediation" Chap-16, Amplification systems for the hearing impaired student in the educational environment, (Pimentel, R.G.), 273, Thieme stratton. New York.
- Ross, M., and Bloomgen (1990): "Earmold modification techniques". Hearing Instruments, 41,1, 20-23.
- Rubin, M. (1975): "Hearing aids currant developments and concepts". Chap- Current development in hearing aids, 3-50, UniversityPark Press, Maryland.
- Rubin, M. (1975):"Hearing aids current developments and concepts" Chap. Electroacoustical standards, 53-87 University Park Press, Maryland.
- Rubin, M. (1975):"Hearing aids: Current developments and concepts Chap. Hearing aids for infants 93-137, University Park Press, Maryland.

(iv)

- Sammeth, C.A. (1989): "From vacuum tubes to digital microchips". Hearing Instruments 40,10, 9-12.
- Sandlin, E., and Andersen, H. (1989): "Development of a remote controlled programmable hearing system". Hearing Instruments, 40, 4, 33.
- Schermacher, M.T., Melanesia, B.B. (1973): "Manual for interpreting audiologic tests" Chap. Programmed audiograms, 33-116, Louisiana State University School of Medicine, Dept. of Otorhinolaryngology and Biocommunication.
- Skinner, M.W. (1988): "Hearing aid evaluation" Chap-4, Measuring sounds for hearing aid: Hearing aid, 78, Prentice Hall, Englewood Cliffs, New Jersey.
- Skinner, M.W.(1988) : "Hearing aid evaluation" Chap-7, Criteria for prescribing maximum acoustic output - SSPL, 90, 192, Prentice Hall, Englewood cliffs, New Jersey.
- Skinner, M.W.(1988): "Hearing aid evaluation" Chap-8, Prescription of a hearing aid and earmold, 207, Prentice Hall, Englewood Cliffs, New Jersey.
- Skinner, M.W. (19):"Hearing aid evaluation" Chap-9, Measuring a successful fit, 265, Prentice -Hall, Englewood Cliffs, New Jersey.
- Srinivas, N.C.(1987) : "A question bank on hearing aids" An Independent Project submitted as a part of fulfilment of M.Sc., (Speech and Hearing) to the University of Mysore.
- Staff, W.I.(1988): "Development of a programmable BTE hearing instrument". Hearing Instruments, 39, 8, 22-66.
- Suchitha (1990): "Guide for the hearing aid user". An Independent Project submitted as a part of fulfilment of M.Sc., (Speech and Hearing), to the University of Mysore.

(v)

Venkovius, T. and Mendora, L. (1985) : "Digital amplification perspectives". Hearing Instruments, 140, 1, 23-24.

Yanick, P., and Friefeld (1978) : "Application of signal processing concept to hearing aidg", Chap-3. A critical review of current hearing aids. Research needs, 45, Grune and Stratton Inc, New York.

Yanik, P. and Friefeld (1978): "Application of signal processing concept to hearing aids", Chap-6, The electroacoustic dimensios of hearing aids, 125, Grune and Stratton, New York.