

PROJECT REPORT

Development of some auditory related cognitive tests: Assessment of cognitive reserve in individuals with older adults

AIISH Research Fund Project No. SH/CDN/ARF-AUD-9/ 2018 - 2019

Authors

Prof. Ajith Kumar U (PI)

Prof. Hemanth N (Co-PI)

Table of content

<i>Abstract.....</i>	<i>4</i>
<i>Chapter-1 Introduction</i>	<i>6</i>
Background.....	6
Need for the Study	9
Aim of study	11
Objectives of study	11
<i>Chapter-2 Method</i>	<i>12</i>
2.1 Participants.....	12
Acceptable noise level (ANL)	13
System Architecture	14
Software	15
Stimulus preparation platform	15
2.3.1.1. Testing environment platform.....	18
Hardware.....	20
Assessing the listening effort.....	22
Stimuli and generation of noise	22
Procedure	22
2.4.1.1. Stimulus Preparation to assess Listening Effort in the Software	22
2.4.1.1. Presentation of stimuli	23
2.4.1.3. Analyses of listening effort	24
<i>Chapter-3 Results.....</i>	<i>26</i>
Repeat and recall scores of listening effort test	26
Relationship between age and listening effort.....	27
Relationship between acceptable noise level and listening effort	29
Predicting listening effort from Age and ANL.....	30
To relate and predict the listening effort after controlled the level of the annoyance towards noise in the participants	31
<i>Chapter-4 Discussion</i>	<i>36</i>
<i>Reference</i>	<i>40</i>
<i>APPENDIX -1</i>	<i>43</i>

List of Figures

Figure- 1 represents software and hardware architect to assess listening effort	14
Figure-2 depicts the assignment of SNR for the selected speech and noise files. The number of selected files of speech and noise corresponding to the SNR is seen in the table.....	15
Figure-3 represents the project setting for listening effort.....	16
Figure-4 represents the window for primary task.....	19
Figure-5 represents the window for secondary task	20
Figure-6 represents the architect of the audio router, which receives the input from the sound card of the laptop, and its output is delivered through the loudspeakers.....	21
Figure-7. Repeat and recall scores at 0 dB SNR and 4 dB SNR of the dual-task paradigm to account for listening effort.....	27
Figure- 8. Scatter plot showing the relationship between age and recall score at 0 dB SNR (less favorable) and 4 dB SNR (relatively favorable).	28
Figure- 9. Scatter plot showing the relationship between ANL and recall score at 0 dB SNR (less favorable) and 4 dB SNR (relatively favorable).	29
Figure-10. A 3 D scatter plot showing the relationship between age (x-axis) and ANL (z-axis) on the recall score (y-axis) at 0 dB SNR (less favorable) and 4 dB SNR (relatively favorable).....	31
Figure-11. Scatter plot showing the relationship between the residue of recall score and the residue of annoyance value after controlled the factor 'age' in less favorable condition.....	32
Figure-12. Scatter plot showing the relationship between the residue of recall score and the residue of annoyance value after controlled the factor 'age' in relatively favorable conditions.....	34

Abstract

Objectives: The study aimed to investigate the listening effort in individuals with older adults who have/had a varied level of annoyance towards the noise. The objectives of the study were a) to develop listening effort software, b) to determine the relationship between listening effort and age; and annoyance towards the noise at less favorable and relatively favorable conditions c) to predict the listening effort from age alone, and ANL alone and combination of age and ANL d) to find the relationship between listening effort and ANL, when the factor age was controlled and vice versa and e) to predict the listening effort from ANL when the factor age was controlled.

Study Design: We have used a correlative research design. A total of fifty native Kannada speaking adults in the age range of 41-68 years (mean age: 54.28 years; age range is 27 years) have participated in the study. We evaluated the participant's acceptable noise level while listening to speech. Furthermore, the listening effort was evaluated using a dual-task paradigm at 0 dB SNR (less favorable condition) and 4 dB SNR (relatively favorable condition). The repeat and recall score were obtained in each of the conditions.

Results: A mild negative correlation was found between the listening effort and age at 0 dB SNR and 4 dB SNR. Regression model revealed that the listening effort increases by 0.6 % at 0 dB SNR and 0.5 % at 4 dB SNR, in every one-year advance in age. A moderate, negative correlation between listening effort and ANL was observed, irrespective of SNRs. The listening effort increases by 0.9 % at 0 dB SNR and 0.7 % at 4 dB SNR in every one dB change in the value of ANL. At each of the SNRs, we have found no relationship between the

listening effort and the age when their annoyance towards noise was controlled using a partial correlation. Nevertheless, at 0 dB SNR and at 4 d BSNR, a moderate and a mild negative correlation were noted respectively, between the listening effort and the annoyance towards the noise, when the factor 'age' was controlled using partial correlation. The listening effort increases by 0.8 % at 0 dB SNR and 0.6 % at 4 dB SNR in every one dB increase in the value of ANL.

Conclusion: Listening effort increases with the advance in age, and its effect is more in less favorable condition than relatively favorable conditions. However, if the annoyance towards noise is controlled, the impact of age on listening effort was diminutive. On the other way of after controlling the factor 'age,' a listening effort found to be related to the level of annoyance. Furthermore, the listening effort was predicted from the ANL to a moderate degree.

Chapter-1 Introduction

Background

A few older adults with normal hearing have little difficulty in understanding speech in quiet listening, but it inflates when competing for noise shares a similar spectrum of speech (Schneider et al. 2002). It infers that although have/ had normal peripheral hearing mechanism, additional factors such as working memory, attention, processing contributes to difficulties in speech understanding among older adults, especially, in adverse listening condition (Akeroyd, 2008). Larsby et al. (2005) has reported a significant perceived effort in understanding speech among older adults than younger adults with normal hearing in the cognitive tests (semantic decision making, lexical decision making, and name matching) when administered in each of the modalities (text, auditory and audio-visual).

Furthermore, it is more disrupting when the noise is temporally varied (ICRA and Hagerman) than speech babble noise through delivered at + 10 dB SNR. Older adults with normal hearing use more cognitive resources just to attend to speech, with decreased resources available for consequent and successive tasks (Tun et al., 2009; Gosselin, 2011) With evidence from previous research the cognitive decline with age begin as early as 45 years (Singh- Manoux et al., 2012; Degeest et al., 2015). Vaughan et al. (2006) have reported that the listening effort is a predictable factor for speech recognition in noise among older adults only if the audibility is controlled. Thus, it is reasonable to evaluate auditory listening effort, in addition, to the assessment of speech perception in noise.

Sarampallis et al. (2009) and Desjardins and Doherty (2013) who have proclaimed that dual-task paradigm objectively measures the listening effort, which assesses available resources for the perception of speech. Desjardins & Doherty (2013) investigated the effort in listening in older adults and younger adults with normal hearing using speech recognition in noise task. The results revealed that older adults found to have put more effort into listening than younger adults. These findings empirically deduce why older adults feel challenging to follow speech and or avoid an unfavorable listening environment. Older adults often have self-reported more listening effort (increased attention and concentration) to attend to speech. The attributed reason would be explained adequately from the capacity theory of attention developed by Kahneme (1973) who emphasized that older adult listeners give major chunk of their reserve for just to attend speech and an available limited reserve is utilized for subsequent processing of storing information into memory, solving ambiguity by contextual cues and finally generating a quick response to speech. The previous theory is substantiated by the research report of Ruder, Lunner, Behens, Thoren, and Ronnberg (2012) who have observed that the older adults took more time for processing speech stimulus on the dual-task paradigm (recognition as primary task and recall as a secondary task) which assess the listening effort. The previous researchers have reported that their study participants had recognized the word with effort but unable to recall the recognized word at a later period. It indicates that more cognitive resource is allocated for initial processing of speech perception, leaving fewer resources for subsequent recall. The possible reason could be from two sources of distortions that led to more listening effort. The first source of distortion is an unclear speech, especially in noise conditions, in which inherent cues are partly lost and distorted,

which intern increases cognitive demand (Ronnberg, 2003). The second source of distortion is an unclear speech impinges on the listener's ear reaches the brain and further distorted by neural asynchronicity in older adults. Finally, the resultant speech does not represent what the brain is tuned to process. Thus, in the perception stage brain works harder and struggles to interpret the signal, thereby leads to communication breakdown. It is evident that incomprehension, the subsequent process of the message has to be integrated with the retained processing of initial parts of messages for later recall to follow the message. This processing may sometimes (background noise) exceed the capacity limits of working memory. The outcome of it would either end up in slowdown in communication and or commit errors. Thus, listening effort refers to an essential aspect of the cognitive resource, which is necessary for speech perception.

Till date, cognitive resource through listening effort is not examined on individuals who show annoyance towards the noise. The annoyance towards noise is objectively tested using an acceptable noise level (ANL). In this test, a running speech at a most comfortable level (MCL) was presented with noise. The listener's ability to put up background noise while listening to speech was objectively assessed to obtain background noise level (BNL). The difference between MCL and BNL was calculated to achieve ANL in dB. The range of ANL, as reported by Nabelek, Freyaldenhoven, Tampas, Burchfield, and Muenchen (2006), is from 2 to 27 dB. Plyler, Alworth, Rossini, and Mapes (2011) have reported that the ANL can range from -3.5 to 27 dB on average. In contrast, Freyaldenhoven, Plyler, Thelin, Nabelek, and Muenchen (2008) have reported that the ANL values range from -2 to 18 dB.

While there is the quantum number of research that exists on the listening effort in aging, the present study included evaluation of annoyance towards noise in older adults for whom listening effort may vary, to the best of our knowledge, not yet been explored extensively. Furthermore, the relationship between aging and the ANL on listening effort are not as well understood. It is hypothesized that irrespective of advance in age, one who was unable to put up with noise may experience higher effort in listening than who can put up with noise. This is because of pertinent operations in cognitive mechanism are unable to accomplish effectively due to annoyance towards the noise, and the products of primary and asymptotes (earlier) processing may no longer be available when recent (later) processing is complete. In our study, the auditory related dual-task paradigm is adopted to assess listening effort, which is developed by Pichora –Fuller et al. (1995) is computerized for ease of administering on the participants of the study. Further, the developed dual-task paradigm is used to assess the cognitive reserve from the cohort of older adult individuals who shows annoyance level towards the noise.

Need for the Study

Older adults find it challenging to recognize speech in quiet listening condition but significant difficulty observed in a less favourable situation. Tun et al. (2009), Gosselin and Gagne (2011), Desjardins, and Doherty (2013) have suggested that older adults face more effort in listening to speech. For understanding speech other than bottom-up mechanisms, a top-down involvement is necessary to decode speech. With this juncture, we can say cognition is an integral part of listening. The influence of cognition on speech perception

has been focused on in the recent past. In older adults, due to temporal asynchrony or impaired frequency selectivity delivers a distorted input to the brain. Besides, a secondary distortion from background noise further increases cognitive demand on listening effort, especially those who are annoyed towards the noise. Unfortunately, the signal does not represent what the brain has evolved to process. Thus, more amount of cognitive resource is required for attending and segregating noise from speech to interpret the signal received from the cochlea. It means the brain struggles hard in allocating a resource of cognitive ability for speech perception.

It is often that listening in the quiet condition is seldom. Older adults are relatively annoyed/ disrupted in listening to speech in noise than other individuals. It is speculated that individuals who are annoyed/disturbed with noise perhaps require more cognitive resources for selective attention and segregation of noise from speech. Nevertheless, it requires empirical evidence to prove the speculation mentioned above. To the best of our knowledge, no study assesses cognitive reserve in older adults who show varied annoyance towards the noise. Thus, the study necessitates determining how they utilize cognitive resource in their reserve for listening to speech. To objectively assess the auditory listening effort we have used the dual-task paradigm. There is no available software to administer this test in the clinic. Thus, the dual-task paradigm is computerized, such that the developed application software can be used as a standardized tool to assess the cognitive reserve meant for perception of speech. The procedural variability in administering and documenting an error in the outcome can be minimized. The developed test is

administered to assess cognitive reserve available to decode speech on individuals with older adults who have had a varied level of annoyance towards the noise.

Aim of the study

To investigate the listening effort in individuals with older adults has/ had a varied level of annoyance towards the noise.

Objectives of the study

- a) To develop listening effort software using the dual-task paradigm
- b) To determine the relationship between age and listening effort in less favorable (0 dB SNR) and relatively favorable conditions (4 dB SNR).
- c) To determine the relationship between acceptable noise level and listening effort in less favorable (0 dB SNR) and relatively favorable conditions (4 dB SNR).
- d) To determine the relationship between age and listening effort after controlled the factor ANL in the participants of the study at 0 dB SNR and 4 dB SNR.
- e) To predict the listening effort from age after controlled the factor ANL in the participants of the study at 0 dB SNR and at 4 dB SNR.

Chapter-2Method

2.1 Participants

A total of fifty native Kannada speaking adults in the age range of 41-68 years (mean age: 54.28 years; age range is 27 years) have participated in the study. All participants had a normal peripheral hearing in both ears, indicated by pure tone thresholds of 15 dB HL or less between the octave frequencies of 250 to 2 kHz Hz; and < 25 to 30 dB HL from above 2 kHz to 8 kHz. All of them had normal middle ear status suggested by 'A' type tympanogram with reflexes present. They had clinically normal transient evoked otoacoustic emissions (TEOAE) purporting normal outer hair cell functioning. During case history, it was informally ascertained that none of the individuals had any history of exposure to noise, under prolonged medication for any associated problems, psychological and neurological issues. Written informed consent was taken from the participants before the data collection. The study adhered to Ethical guidelines for bio-behavioral research involving human subjects, All India Institute of Speech and Hearing, Mysuru. All the tests were carried out in an air-conditioned sound-treated room. The ambient noise level was within permissible limits ANSI S3.1-1991 (American National Standard Institute, 1991). In addition to the conventional audiological evaluation, each participant was measured for annoyance towards noise using acceptable noise level, and furthermore, listening effort was assessed using dual task paradigm. The values of ANL; and scores of primary and secondary tasks of the listening effort are given in APPENDIX-1.

Acceptable noise level (ANL)

Acceptable noise level evaluates listeners' reactions to a background noise level while listening to speech. For the measurement of ANL, the method given by Nabelek, Tucker, and Letowski (1991) was adopted. The participant was made to sit comfortably on a chair in front of the loudspeaker of the audiometer that was located at 1 m distance and 45° Azimuth from the participant. The following instruction was given to establish the most comfortable level (MCL) on study participant. *“You will listen to a story through the loudspeaker. The loudness of the story will be varied. First, the intensity will be turned up until it is too loud and then turned down until it is too soft. Then the level is adjusted. You have to indicate the level at which the loudness of the story is most comfortable for you”*. The recorded Kannada passage was routed through the auxiliary input of the audiometer to the loudspeaker at the level of speech recognition threshold. Gradually, the level was adjusted in 5 dB-steps up to the level of Most Comfortable Level (MCL) and then in smaller steps size of +1 and -2 dB, until the MCL of the participant was established reliably. These steps were repeated twice, and the MCL obtained was averaged. After determining the MCL, a speech shaped noise was introduced at 30 dB HL. The level of the speech noise was increased in 5 dB-steps initially, and then in 2 dB-steps, to a point at which the participant willing to accept the noise without becoming tired or fatigued while listening to and following the passage. The maximum level at which he/she could accept or put up with the noise without becoming tired is considered as the Background Noise Level (BNL). The level of the speech noise was adjusted until the participant can 'put-up-with' the noise while following the story. These steps were repeated, and the BNL obtained from two trials was averaged. The

ANL quantifies the acceptable level of background noise and is calculated as the difference between MCL (dB HL) and BNL (dB HL) (Nabelek, Tucker, Letowski, 1991). The mean ANL value from the participants of the study accounts to 2.1 dB, minimum ANL value is -7 dB, and the maximum value is 13 dB, and the range of ANL value is 20 dB.

System Architecture.

We developed application software and assembled the audiorouter hardware to assess the listening effort in clients (Figure-1). The developed application software can be loaded into a laptop/ Personal system. The output from the sound card of the laptop is driven as input into an eight-channel relay station. The loudspeakers assigned to deliver the speech and the noise signals are reconnected to the relay station.

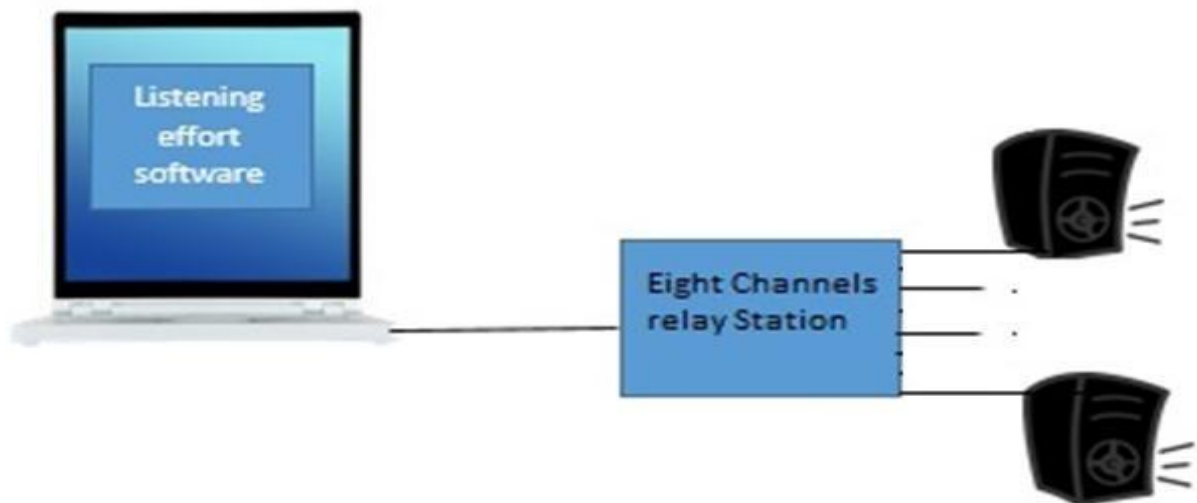

Figure- 1 represents software and hardware architect to assess the listening effort.

Software

The software for the listening effort was written in C# (sharp) on top of a Windows 7 operating system. The software has two platforms. In platform-1, an option is provided for stimulus preparation, and in platform-2, the testing environment is constructed.

Stimulus preparation platform

We have provided two windows in which stimuli are added, and settings in the project are prepared. After demographic entry, the SNRs are assigned to the selected multiple speech files and noise files. The list of the files (speech and noise) added is displayed in the table next to the settings (Figure-2). It mentions the SNR, noise type, speech count (number of speech files), and noise count (number of noise files).

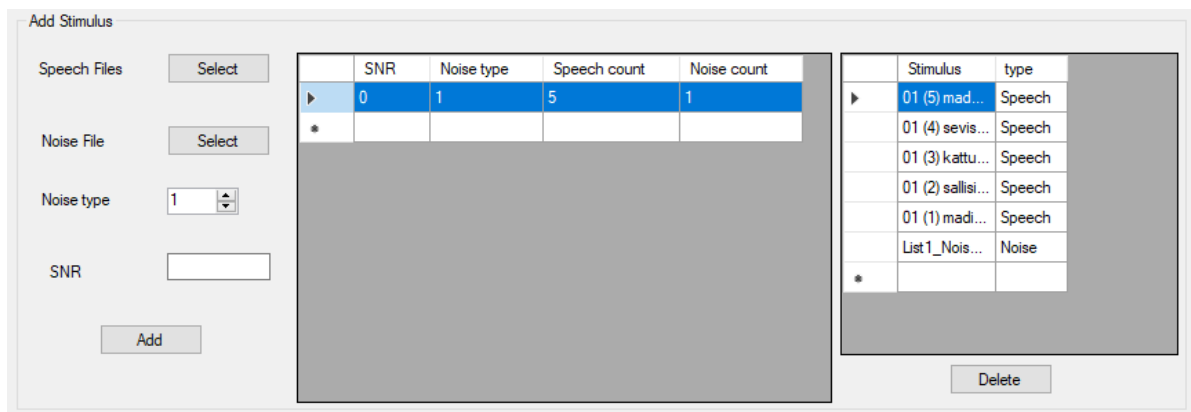

Figure-2 depicts the assignment of SNR for the selected speech and noise files. The number of selected files of speech and noise corresponding to the SNR is seen in the table.

3. Inter-block Interval (IBI) is the duration between the end of the first block and the start of the next block. Block is expressed in msec in which duration of each stimulus in primary task (repeat) plus the ISIs duration collectively called as a block. This is the period where the client has to recall the words. Hence, ensure sufficient time has been allotted here.
4. The audio router should be selected to deliver the speech and noise to the assigned loudspeakers. If it is unchecked, then stimuli (speech and noise) are delivered through headphone [right ear – speech/ noise ; left ear –speech/ noise ; right / left ear - speech + noise]
5. Mix sentence and noise: If it is unchecked, the speech and noise are delivered separately in the assigned loudspeakers at desired SNRs else both the speech and the noise are delivered to the same assigned loudspeaker.
6. Instructions
 - a. Message for the primary task (Repeat Message): The client is asked to repeat the last word of the sentence after the end of every presentation.
 - b. Message for the secondary task (Recall Message): The client is asked to recall the recognized words (free recall manner) as soon as hears the audio beep.
7. Stimulus Presentation Order: The order of the presentation of stimuli concerning the SNR and noise type. It is represented as 'SNR.Noise type'. E.g., 3.1 (SNR-3, Noise type). The order of stimuli in a project can be randomized. The order of the presentation of the stimuli can be changed using the option 'Change order'. If an option 'Counterbalanced' is used then the order of presentation of stimuli assigned to corresponding SNR are randomized across clients. In otherwise to

maintain the order of presentation constant across all the study participants in a project, the box 'Non- counterbalanced' has to be checked in, which is essential to assess the auditory fatigue in a client.

The following options must be selected for evaluating the listening effort among clients.

2.3.1.1. Testing environment platform

The Dual-Task Paradigm test window opens when the 'Start Test' is clicked on. To begin the test, user has to click on the 'Begin' button. The test window shows the order of the presentation of the different SNRs at the top. The name for the speech and noise files that are being played, the recall number, the block number, and the SNR are also shown. These settings are displayed both in the primary and in the secondary task (Figures 4 and 5). The test instruction for the tester is displayed soon after the presentation of each stimulus. After the client's response in the primary task, the researcher/ clinician has to 'Click Right' for the correct response and 'Click Wrong' for the incorrect answer and 'do not click' if there is no response.' *[Note: The below window is only for the tester. The name of the speech file can be saved as the last word such that it is displayed for verification of correct or incorrect responses given by the client]*

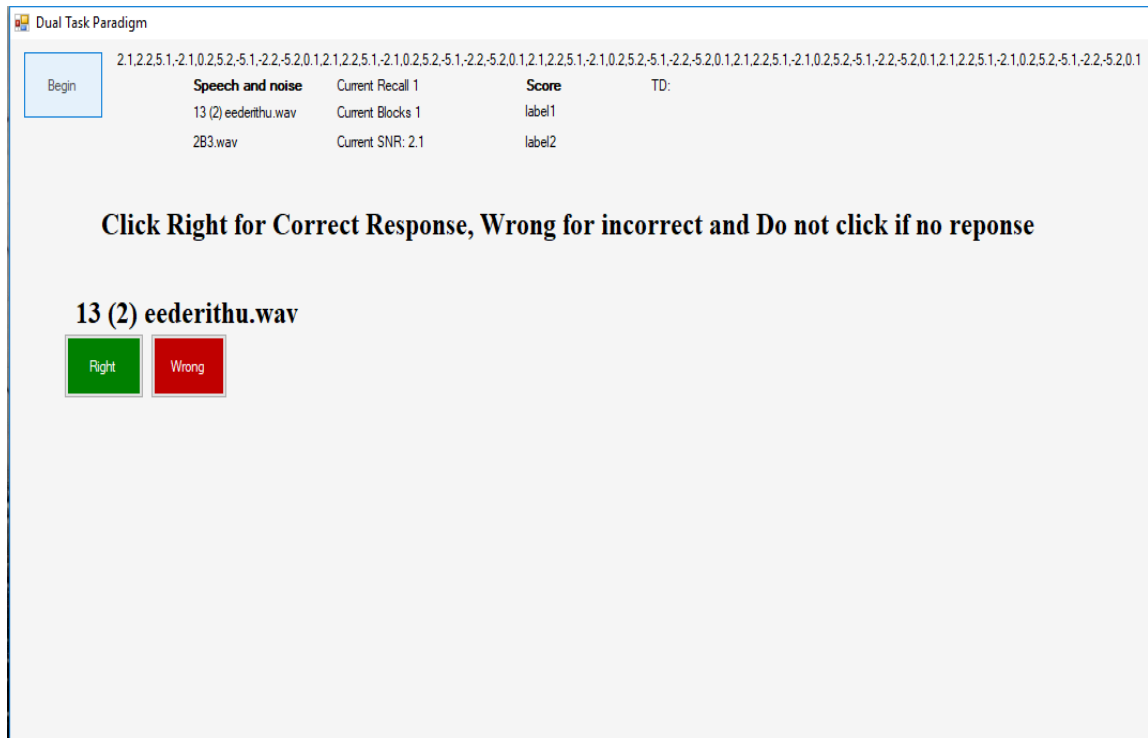

Figure-4 represents the window for the primary task.

In the secondary task, an audio beep is heard as a cue. Then the client has to remember and recall the recognized words of the primary task in a free recall manner. The instruction for the tester is displayed soon after the end of the block. For each of the stimuli in the block, the corresponding options are displayed, such as 'Click Right' for correct recall and 'Click Wrong' for incorrect recall and 'do not click' if the client unable to recall either the recognized or not recognized word.

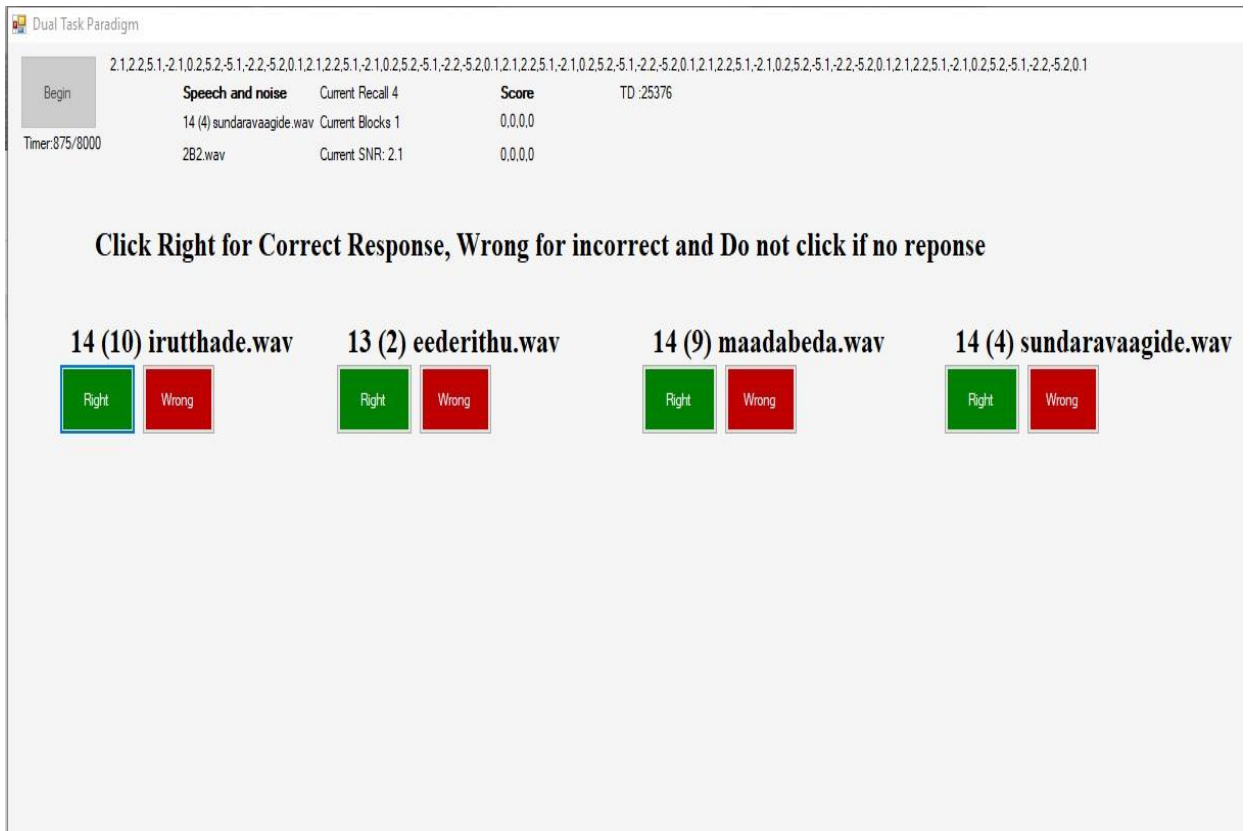

Figure-5 represents the window for the secondary task.

Hardware

The built-in sound card reliably represents the digital output in stereo (2 tracks) mode with a sampling rate of 48 kHz. The output of the sound card is fed into the eight channels audio router (Figure-6). An audio-router is hardware that is used to dynamically deliver the stimuli (speech and noise) through the loudspeakers positioned at different azimuths. The audio router comprised of 8 channel 2 AMP solid state relay board which control eight loads of up to 2 amps each at 120V or 240V AC with an operating voltage of 5 V. The Input control of sound card has two state of operations such as normally closed (NC [0 V to <2.5 V]) and normally opened (NO [>2.5. V to 20 V]). The input signal voltage is set to 5 V in the channels (on) where the noise and speech tracks are assigned. The channels in

the relay board are said 'off' when the voltage is set at 0 V where no tracks (noise and speech) of the signal are assigned. The output from the audio router is delivered to the assigned loudspeakers. The frequency response of Genelec loudspeaker is 23 Hz to 40 kHz (-6 dB) with a ± 1 dB (29 Hz to 20kHz), which can produce the maximum SPL of 113 dB with an inbuilt amplifier power [150W Bass + 120W Midrange + 120W Treble]. In our present study, the signals are presented at the participant's most comfortable level.

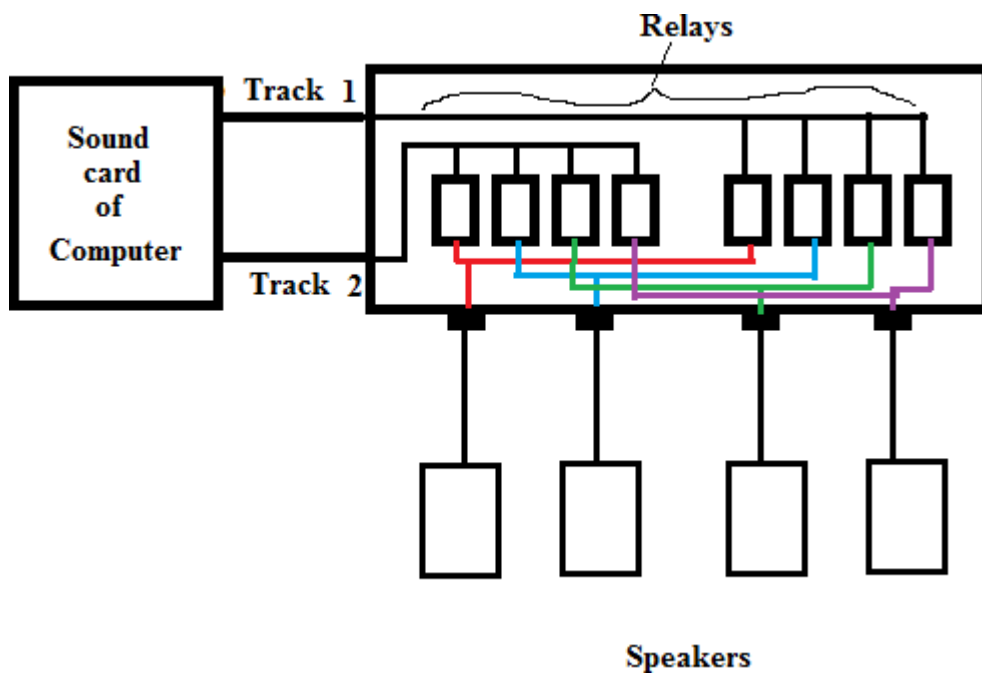

Figure-6 represents the architect of the audio router, which receives the input from the sound card of the laptop, and its output is delivered through the loudspeakers.

Assessing the listening effort

Stimuli and generation of noise

Twenty four lists of standardized Kannada sentences were used as the target stimuli in the dual-task paradigm to assess listening effort (Geetha et al., 2014). Each list consisted of ten sentences. The noise used was speech shaped noise, and it was prepared using MATLAB (version- 2013b). The sentences were concatenated. The speech spectrum was performed for every 100 msec (short bin) and summated to derive its long-term average speech spectrum (LTASS). White noise was passed through Infinite impulse response (IIR) filter and fed to inverse filtering to derive the long term average spectrum similar to the spectral characteristics of target sentences used in the study.

Procedure

The procedure for the dual-task paradigm to assess listening effort was adopted from Pichora-Fuller et al. (1995). It consists of two tasks- primary and secondary. The primary task required the participant to repeat the last word of the sentence. In the secondary task, the participant had to recall all the words repeated in a block. In the present study, each block consisted of five sentences.

2.4.1.1. Stimulus Preparation to assess Listening Effort in the Software

The listening effort software was loaded in the HP laptop has an Intel (R) Core (TM) i5 processor, a 4 RAM, and a 64-bit operating system with the standard sound card. A new project was created in the software. The target Kannada sentences were loaded as the 'Speech files.' The speech shaped noise generated was uploaded as the 'Noise file' with

'Noise Type 1'. The target sentences were mixed at two SNRs- 0 dB SNR (120 sentences) and 4 dB SNR (120 sentences). This resulted in a total of 240 target sentences.

The recall number was set to '5', and hence there were five sentences in every block. The number of blocks per SNR was 24 (Number of sentences/ Recall number). Therefore, the total number of blocks was 48. The duration between every sentence in the primary task was considered as the 'inter-stimulus interval' (ISI). It was set to 3000 ms. The inter-block interval (IBI) was the duration between the presentation of two consecutive blocks, and it was set to 10000 ms. Random order of presentation of SNR was generated by the software for the first participant. This order was followed for the rest of the participants (non-counter-balanced). A calibrated 1 kHz tone generated was presented at 65 dB SPL. The volume of the laptop is increased until the output through the loudspeaker (Genelec) reads 85 dB SPL in the sound level meter.

2.4.1.1. Presentation of stimuli

The stimuli were presented through loudspeakers. Three loudspeakers positioned at 0°, +45°, and -45°, kept 1 m away from the participant. At 0° azimuth, a target standardized Kannada sentences was delivered and the speech shaped noise was presented through the loudspeaker positioned at +45°, and -45°. At participant's most comfortable level (MCL) (See procedure of MCL in ANL section) the listening effort was determined at 0 dB SNR (less favorable condition) and 4 dB SNR (relatively favorable condition). Each participant was instructed that the sentences would be presented in multiple blocks, and each block would contain five sentences. They were instructed to repeat the last word of every sentence presented (primary task). They were also

encouraged to guess the words if they were uncertain. Participants were asked to remember their responses as they would have to recall the same later. After the presentation of five sentences, an audio beep (pure tone of 200 ms) was played. This was an indication for the participant to recall the words repeated (secondary task). The order of recall was not considered. The tester documented the repeat and recall responses of the participants in the software.

2.4.1.3. Analyses of listening effort

A score of 1, -1, and 0 were awarded for correct, incorrect, and no response, respectively, for the primary and the secondary tasks. With five sentences in each of the 24 blocks (block count per SNR), the maximum repeat score per SNR was 120. Similarly, for the recall task, the maximum score per block was 5 (irrespective of the order). This was true for every block of each SNR. Scores were represented as a) Repeat scores and the b) Recall scores. The following formula was used to convert the raw score into a percentage then into arcsine units.

Primary Task - Repeat score

Raw score = Σ Sum of scores in each block

Percentage score = $\text{Raw score} / (\text{Recall} * \text{Block count}) * 100$

Secondary Task - Recall Score

Raw score = Σ (Recall score/Recall count of each block)

Percentage score = $(\text{Raw score} / \text{Block count}) * 100$

The primary task and the secondary task scores, in percentage, were converted into rationalized arcsine unit transform with the excel (Hoen, 2015) before statistical analysis to stabilize the error variance. The formulae are given below.

$$AU = ASIN(\sqrt{S / (N+1)}) + ASIN (\sqrt {(S+1)/(N+1)}) \text{ -----(1)}$$

AU: the score transformed to arcsine units.

S: 'score': the cell in the excel sheet containing your number of correct responses.

N: 'number': the cell in the excel sheet containing the number of trials that were performed.

$$RAU = (46,47324337 * AU) - 23 \text{ -----(2)}$$

AU: the cell in the excel sheet containing scores transformed to arcsine units using (1).

Chapter-3 Results

The effort of noise on listening effort using the dual-task paradigm was assessed upon the participants of the study within the age range of 41 to 68 years (range 27 years) in whom their annoyance towards noise was also accounted. The obtained ANL value and the listening effort [primary task (repeat score) and the secondary task (recall score)] at two conditions [0 dB SNR – less favorable condition and 4 dB SNR – relatively favorable condition] from the participants of the study were subjected to Statistical package for social science SPSS (version-21). The results under each of the objectives are given below.

Repeat and recall scores of listening effort test

A dependent samples test was conducted to compare the repeat and recall score obtained at 0 dB SNR and at 4 dB SNR. The results revealed a significantly reduced repeat score at 0 dB SNR than at 4 dB SNR ($t(49) = -11.22, p=0.000$). Similarly, a reduced recall score was noted at 0 dB SNR than at 4 dB SNR, which was found significant ($t(49) = -18.53, p=0.000$). On the comparison between repeat and recall scores at each of the SNRs, it was observed that when the repeat score was less, their recall score was also found to be less (at 0 dB SNR), and vice versa (4 dB SNR). It purports that the performance in the primary task (repeat) showed the amount of effort that the participants of our study 'put in' in the secondary task (recall). On average, 6 % in the recall score and 16 % in the repeat score were reduced when the listening condition was changed from relatively favorable (4 dB SNR) to less favorable conditions (0 dB SNR). Listening effort was calculated as the change

in a participant's performance on the secondary task (Pichora-Fuller & Singh, 2006). Thus in the rest of the results, only recall call was considered to document the listening effort. We have used listening effort and recall scores interchangeably.

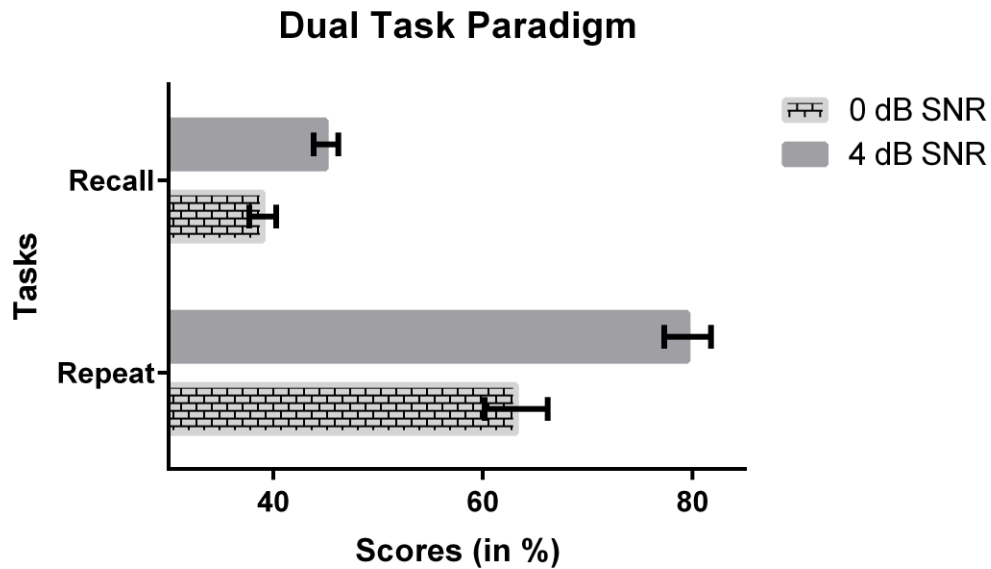

Figure-7. Repeat and recall scores at 0 dB SNR and 4 dB SNR of the dual-task paradigm to account for listening effort.

Relationship between age and listening effort

A Pearson product-moment correlation coefficient analyses were used to examine the relationship between the age and recall scores at 0 dB SNR and 4 dB SNR. Results indicated an mild negative correlation between the age and the scores on the listening effort at 0 dB SNR, [$r(49) = -0.412$, $N=50$, $p = 0.003$], and at 4 dB SNR, [$r(49) = -0.383$, $N=50$, $p = 0.006$]. This suggests that listening effort increases (recall score reduces) in advanced with age in less favorable (0dB SNR) and relatively favorable (4 dB SNR) conditions (Figure 8).

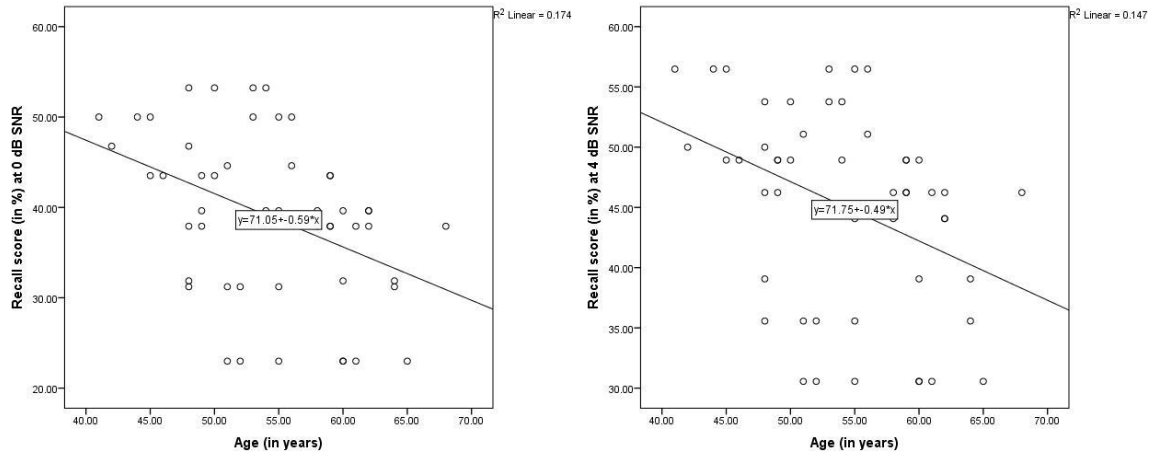

Figure- 8. Scatter plot showing the relationship between age and recall score at 0 dB SNR (less favorable) and 4 dB SNR (relatively favorable).

A simple linear regression was carried out to investigate the relationship between age and recall scores at 0dB SNR and 4 dB SNR. The ANOVA helps us to decide whether the regression line does any better at prediction. The prediction is significant, and so we would conclude that in this case, our regression line is significantly better at predicting the recall score from age at 0 dB SNR [$F(1, 48) = 10.14, p = .003$] and at 4 dB SNR [$F(1, 48) = 8.27, p = .005$]. R^2 is 0.174 and 0.147 at 0dB SNR and 4 dB SNR, respectively, suggesting that about 17 % and 14 % of the variation in the listening effort can be accounted for by this variable's relationship with the age. The slope coefficient for recall score was -0.590 at 0 dB SNR and -0.492 at 4 dB SNR, so the listening effort increases by 0.6 % at 0dB SNR and 0.5 % at 4 dB SNR in every one-year advance in age by the participants of the study (Figure 8). Equation to predict listening effort or otherwise recall score from the age is given by the formula $y = a + b(x)$ ($a=71.05; b=-0.590$) at 0dB SNR and ($a=71.72; b=-0.492$) at 4 dB SNR.

Relationship between acceptable noise level and listening effort

A Pearson product-moment correlation coefficient was computed to assess the relationship between recall score and the amount of annoyance towards the noise can put up with (ANL). There was a negative correlation between the two variables, [$r = -0.547$, $n = 49$, $p = 0.000$] at 0 dB SNR and [$r = -0.467$, $n = 49$, $p = 0.000$] at 4 dB SNR, respectively. A scatterplot summarizes the results (Figure 9) Overall, there was a moderate, negative correlation between listening effort and ANL, irrespective of SNRs. It infers that the recall score reduces with an increase in ANL at each of the SNRs.

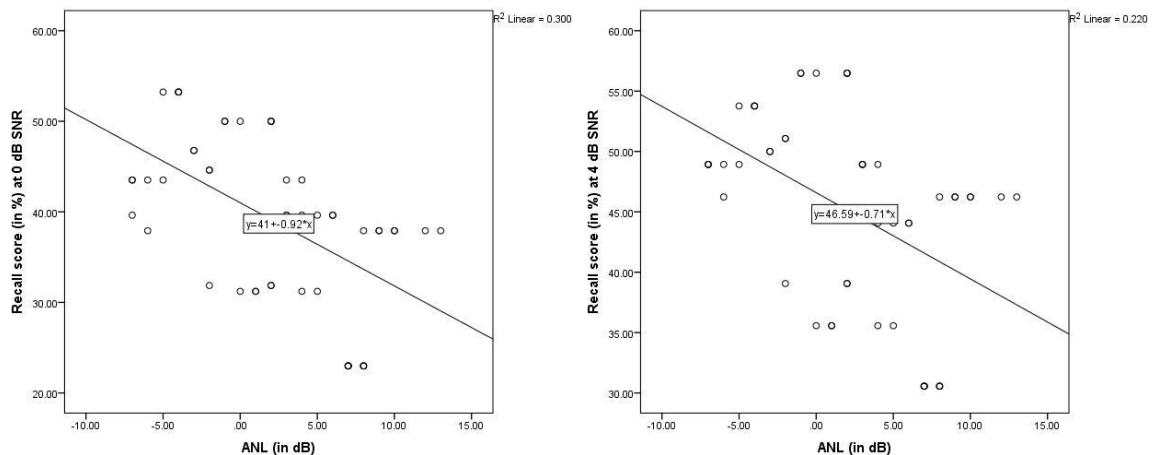

Figure- 9. Scatter plot showing the relationship between ANL and recall score at 0 dB SNR (less favorable) and 4 dB SNR (relatively favorable).

A simple linear regression was carried out to investigate the relationship between ANL and recall scores at 0dB SNR and 4 dB SNR. The ANOVA helps us to decide whether the regression line does any better at prediction. The prediction is significant, and so we would conclude that in this case, our regression line is significantly better at predicting the recall

score from age at 0 dBSNR [$F(1, 48) = 20.54, p = 0.000$] and at 4 dB SNR [$F(1, 48) = 13.51, p = 0.001$]. R^2 is 0.300 and 0.227 at 0 dB SNR and 4 dB SNR, respectively, suggesting that about 30 % and 22 % of the variation in the listening effort can be accounted for by this variable's relationship with the ANL. The slope coefficient for the recall score was -0.919 at 0 dBSNR and -0.714 at 4 dBSNR, so the listening effort increases by 0.9 % at 0dBSNR and 0.7 % at 4 dB SNR in every one dB change in the value of ANL (Figure 9). Equation to predict listening effort or otherwise recall score from the age is $y = a + b(x)$ ($a=41.05; b = -0.919$) at 0 dB SNR and ($a=46.58; b = -0.714$) at 4 dB SNR.

Predicting listening effort from Age and ANL

A multiple regression analysis was conducted to examine the relationship between age and ANL on the listening effort for the less favorable and relatively favorable conditions. Irrespective of condition, as can be seen from Figures 10 the age and the ANL is negatively correlated with the score of listening effort, indicating that those with advanced age and higher scores on ANL tend to have reduced recall score or otherwise effort in listening is more. The multiple regression model with two predictors (age and ANL) to predict the listening effort produced $R^2 = 0.557, F(2, 49) = 10.55, p = 0.000$ for 0 dB SNR and $R^2 = 0.484, F(2, 49) = 7.176, p = 0.002$ for 4 dB SNR, respectively. An about 50 % and 48 % of the variation in the listening effort can be accounted for by this variable's relationship with the age and the ANL for 0dB SNR and 4 dB SNR, respectively. The slope coefficient for the recall score was -0.182 for age and -0.785 for ANL at 0 dBSNR, so the listening effort increases by 0.2 % accounted from age and 0.8% considered from ANL. Whereas the slope coefficient at

4 dB SNR for recall score was -0.195 for age and -0.571 for ANL, so the listening effort increases by 0.2 % accounted from age in every one-year advances in age and 0.6 % considered from annoyance towards noise for every one dB change in the values of ANL. Equation to predict listening effort or otherwise recall score from the age and ANL is $y = a + b_1(x_1) + b_2(x_2)$ ($a = 50.59$; b_1 (age) = -0.182 and b_2 (ANL) = -0.785) at 0 dB SNR and ($a = 56.86$; $b_1 = -0.195$ (age) and $b_2 = -0.571$ (ANL)) at 4 dB SNR.

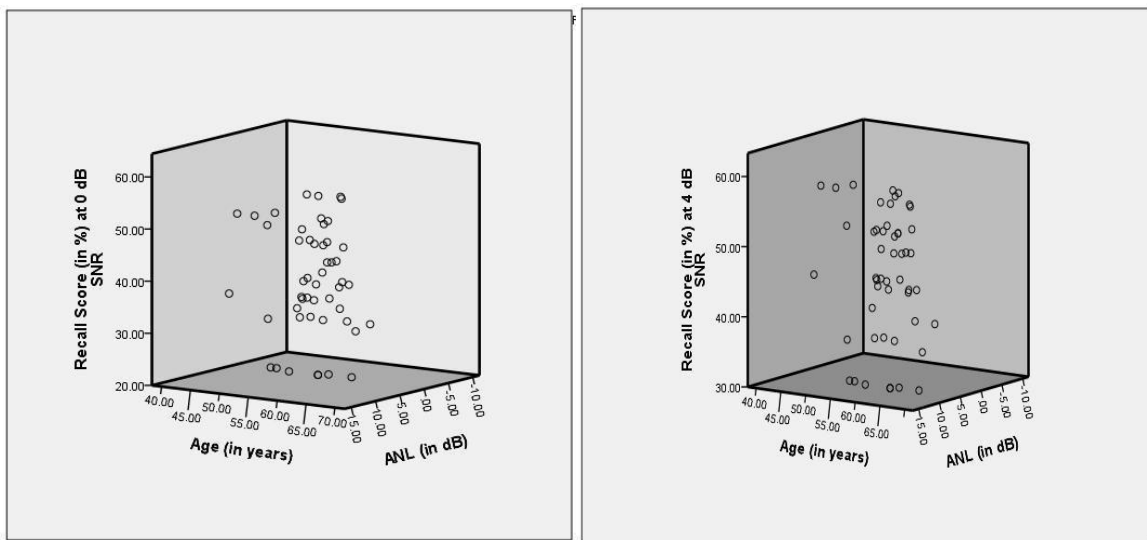

Figure-10. A 3 D scatter plot showing the relationship between age (x-axis) and ANL (z-axis) on the recall score (y-axis) at 0 dB SNR (less favorable) and 4 dB SNR (relatively favorable).

To relate and predict the listening effort after controlled the level of the annoyance towards noise in the participants

At 0 dB SNR – less favorable condition

A partial correlation was administered to determine the relationship between an individual's recall score and age while controlling their annoyance towards the noise

(ANL). A result revealed that there was no relationship between recall score and age [$r(47) = -0.121, N=50, p= 0.408$] when ANL was controlled. However, zero-order correlation revealed a moderate, negative relationship between listening effort and age [$r(48) = -0.418, N=50, p= 0.003$], indicating the recall reduces (listening effort increases) with advances in age.

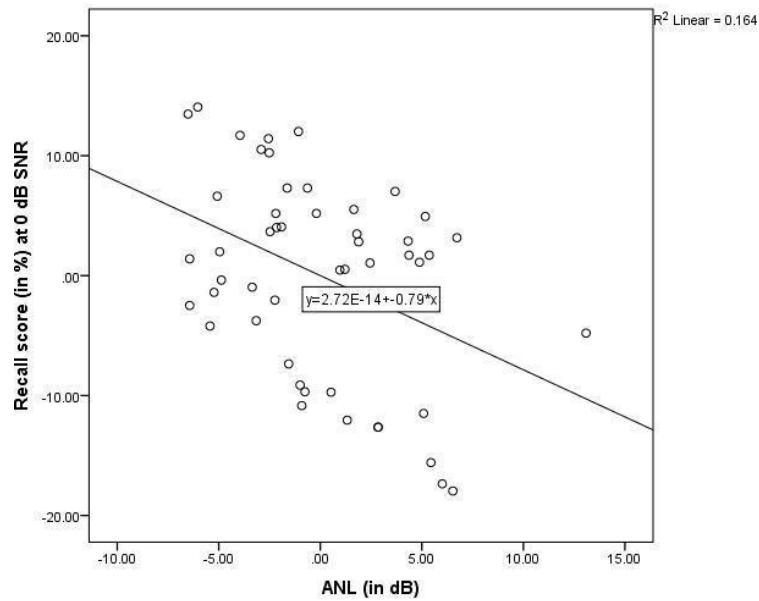

Figure-11. Scatter plot showing the relationship between the residue of recall score and the residue of annoyance value after controlled the factor 'age' in less favorable condition.

Furthermore, a partial correlation was run to evaluate the relationship between an individual's recall score and ANL while controlling the factor 'age.' Results revealed that there was a moderate, negative correlation between recall score and annoyance towards the noise (ANL) [$r(47) = -0.405, N=50, p= 0.004$] when age was controlled, indicating an increase in ANL values increase the effort in listening. A residue of what is leftover on controlling the variable 'age' is scatter plotted with ANL and recall score is depicted in

Figure 11. Besides, a linear regression was administered on the residue of the ANL and the listening effort after controlled the factor 'age.' The prediction is significant, and so we would conclude that in this case, our regression line is significantly better at predicting the recall score from an individual's annoyance towards noise [$F(1, 49) = 9.422, p = 0.004$]. R^2 is 0.164, suggesting that about 16 % of the variation in the listening effort can be accounted for by this variable's relationship with the annoyance when the factor 'age' was controlled. The slope coefficient for the recall score was -0.785, so the listening effort increases by 0.8 % in every one dB increase in ANL by the participants of the study. Equation to predict listening effort or otherwise recall score from the ANL is $y = a + b(x)$ ($a = 1.27; b = -0.78$).

At 4 dB SNR – relatively favorable condition

A partial correlation was administered to determine the relationship between an individual's recall score and age when controlled the factor ANL. A result revealed that there was no relationship between recall score and age [$r(47) = -0.135, N=50, p= 0.354$] when 'ANL' was controlled. However, zero-order correlation revealed a mild, negative correlation between listening effort and age [$r(48) = -0.383, N=50, p= 0.006$], indicating the recall reduces (listening effort increases) with advances in age.

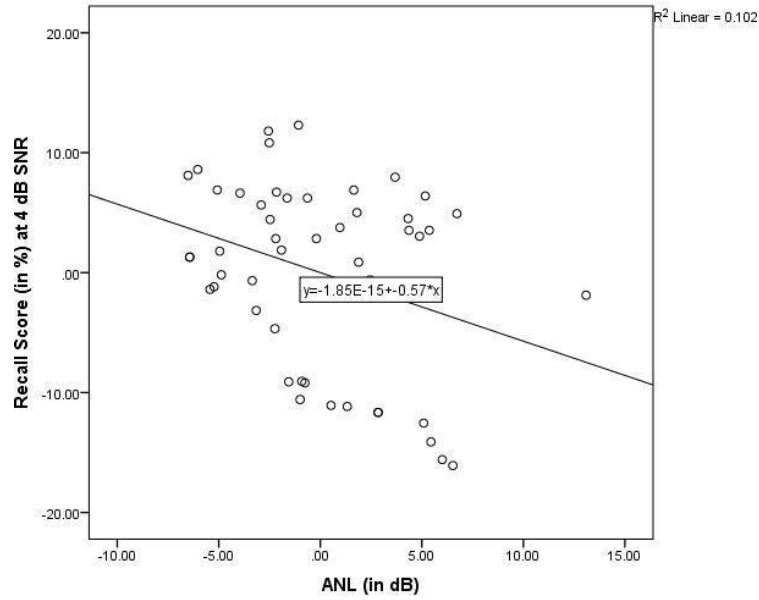

Figure-12. Scatter plot showing the relationship between the residue of recall score and the residue of annoyance value after controlled the factor 'age' in relatively favorable conditions.

Furthermore, a partial correlation was run to evaluate the relationship between an individual's recall score and ANL while controlling the factor 'age.' Results revealed that there was a mild, negative correlation between recall score and annoyance towards the noise (ANL) [$r(47) = -0.319, N=50, p = 0.025$] when the factor 'age' was controlled, indicating that the increase in ANL values increases the effort in listening. A residue of what is leftover on controlling variable 'age' are scatter plotted with the ANL and the recall score is depicted in Figure 12. In addition, a linear regression was administered on the residue of the ANL and the listening effort after controlled the factor 'age.' The prediction is significant, and so we would conclude that in this case, our regression line is significantly better at predicting the recall score from an individual's annoyance towards noise [$F(1, 49) = 5.446, p = 0.024$]. R^2 is 0.102, suggesting that about 10 % of the variation in the

listening effort can be accounted for by this variable's relationship with the annoyance when the factor 'age' was controlled. The slope coefficient for the recall score was -0.571, so the listening effort increases by 0.6 % in every one dB increase in the ANL by the participants of the study. Equation to predict the listening effort or otherwise recall score from the ANL is $y = a + b(x)$ ($a = 1.01$; $b = -0.57$).

Chapter-4 Discussion

In the clinic, we have heard that older adults complaining of unable to follow speech in adverse listening condition and middle-age people often shows grievance on speech being unintelligible, especially in adverse listening condition. When the noise distorts the essential cues, the cognitive reserve at higher centers uses most of the resources to compensate for the loss of information that occurred at the peripheral system, which makes the listening more effortful. The listening effort increases with the advance in age, and its effect is more when listening condition changes from favorable to less favorable condition. It was found, a mild negative correlation and be able to predict the listening effort by 17 % at 0 dB SNR and 14 % at 4 dB SNR from the age. A mild negative correlation was found, and the listening effort increases by 0.6 % at 0 dB SNR and 0.5 % at 4 dB SNR in every one-year advance in age by the participants of the study. This is because of the age of the participants deployed in our study ranged within 41- 68 years. The age-related cognitive and sensory decline starts at the age of 40 years and above (McCoy et al., 2005; Tun et al., 2008; Wingfield & Tun, 2001; Singh-Manoux et al. (2012)). Thus, a mild negative correlation was observed in listening effort with advances in age. The findings of the present study are partly consensus with the previous reports of Desjardins & Doherty, (2013) Gosselin & Gagné, (2011); and Tun, McCoy, & Wingfield, (2009) who have reported that older adults found to have increased listening effort than younger adults. From Figures 8 and 9, it is clear that the listening effort has equivocal scores within the age range from 45 to 60 years. The study participants had normal to near normal lower-level sensory processes as a function of advanced in the age, which is reflected in their audiogram. Those individuals who have got lower scores on listening effort is because of reduced attention,

working memory, and processing speed. Consequently, when listening condition is less favorable, a higher level of cognitive load is required to decipher the information to compensate for the peripheral processing due to loss of information where cues are buried in noise. Thus, the listening becomes more effortful, which was reflected in the score of recall score. When we analyzed the pattern of recall scores in those individuals who have received reduced recall scores, it was found that they can recall a few initial words (primacy effect) and the last word (recency effect) but finds it difficult to recall the middle words (asymptote). The results on the pattern of recall are in consonance with the research report of Lunner et al. (2016). The attributed reason could be a more cognitive resource is available to segregate the noise from speech. With the available resource, they could have managed to rehearse a few initial words and put it in the short term memory for later recall and left with relatively less or no reserve to recall the words of the middle order, which were recognized in the primary task.

A moderate, negative correlation was found between listening effort and ANL, irrespective of SNRs. The listening effort increases by 0.9 % at 0 dB SNR and 0.7 % at 4 dB SNR in every one dB change in the value of ANL. The result suggests that individuals' differences in ability to put up with noise are likely to affect listening effort when the listening conditions are unfavorable. In individuals who are unable to put up with noise takes a significant chunk of a cognitive resource than their counterpart to segregate the noise from speech. A smaller reserve is left in them to do successive tasks, such as putting the attended words into short memory, rehearsing it for later recall and consequently attaching meaning to it.

Nevertheless in individuals who are able to put up with more noise are good at allocating the mental

resource to segregate the noise from speech, and the available resources are utilized to do the successive cognitive tasks to follow the speech effortlessly. It purports that those individuals who have less annoyance towards noise mitigate the detrimental effects of difficult listening conditions.

After controlling the factor 'ANL' using partial correlation, it was found no relationship between the recall score and the age. This was true for each of the SNRs. However, at 0 dB SNR, a moderate, and at 4 dB SNR, a mild, negative correlation was noted between the listening effort and the annoyance towards the noise, when controlled the factor 'age.' The listening effort increases by 0.8 % at 0 dB SNR and 0.6 % at 4 dB SNR in every one dB increase in the ANL by the participants of the study. It infers that annoyance of noise is the predictive component of listening effort rather than the age of study cohort. This is because the input signals loss the important cues elicit the mismatch between what is heard and representation of those words in the mental lexicon. In individuals who are unable to withstand, noise recruits more resources in storage and process the input signal in their short term memory to resolve the mismatch. With no time a successive word arrives and left with less time available for a rehearsal for later recall. This process continues, but at some juncture, the cognitive resource is unable to expend the available limit such that they recalled either the initial or final words but finds it difficult to remember the words in the middle order leads to effortful listening. The above-explained phenomenon is more pronounced linearly with every one dB increase in annoyance towards the noise.

Conclusions

Irrespective of advance in age, one who was unable to put up with noise may experience higher effort in listening than who can put up with noise. This is because major cognitive resources are utilized just to attend to the target speech and segregate the noise. A minimal reserve available for pertinent operations in cognitive mechanism are unable to accomplish effectively due to annoyance towards the noise, and the products of primary and asymptotes (earlier) processing may no longer be available when recent (later) processing is complete.

Implication

Cognitive functions are essential for speech communication. Listening effort found to be the best possible test to assess cognitive function meant for speech perception with less time in routine clinical practice. Annoyance towards noise has a moderate relation with listening effort when the age factor was controlled. The listening effort in the study cohort made to understand better the complaints about speech recognition in noise indicated by middle-aged and older adults.

Reference

- Akeroyd, M. A. (2008). Are individual differences in speech reception related to individual differences in cognitive ability? A survey of twenty experimental studies with normal and hearing-impaired adults. *Int J Audiol*, 47 Suppl 2:S53-71. doi: 10.1080/14992020802301142.
- capacity may influence perceived effort during aided speech recognition in noise. *J Am Acad Audiol*, 23(8), 577-89. doi: 10.3766/jaaa.23.7.7.
- Degeest, S., Keppler, H & Corthalsa, P. (2015). The Effect of Age on Listening Effort *Journal of Speech, Language, and Hearing Research*, 58, 1592–1600.
- Desjardins, J. L., & Doherty, K. A. (2013). Age-related changes in listening effort for various types of masker noises. *Ear & Hearing*, 34, 261–272.
- Freyaldenhoven, M. C., Plyler, N. P., Thelin, W. J., & Muenchen, A. R., (2008). Acceptance of Noise Growth Patterns in Hearing Aid Users. *J Speech Lang Hear Res*, 51 (1), 126-35.
- Geetha, C., Sharath, K. S., Manjula, P., & Pavan, M (2014). Development and standardisation of the sentence identification test in the Kannada language. *Journal of Hearing Science*, 4, 18- 26
- Gosselin, P., & Gagné, J. P. (2011). Older adults expend more listening effort than young adults recognizing speech in noise. *Journal of Speech, Language, and Hearing Research*, 54, 944–958
- Hoen, M. (2015). Using the rationalized arcsine unit transform with excel. technical report Retrieved from. https://www.researchgate.net/publication/272676356_Using_the_rationalized_arc_sine_unit_transform_with_Excel/citation/download.
- Kahneman, D. (1973). *Attention and effort*. Englewood Cliffs, NJ: Prentice-Hall.
- Larsby, B., Hällgren, M., Lyxell, B., & Arlinger, S. (2005). Cognitive performance and perceived effort in speech processing tasks: effects of different noise backgrounds in normal-hearing and hearing-impaired subjects. *Int J Audiol*, 44(3), 131-43.
- Lunner, T., Rudner, M., Rosenbom, T., Ågren, J., & Ning Ng, H, E. (2016). Using Speech Recall in Hearing Aid Fitting and Outcome Evaluation Under Ecological Test Conditions. *Ear and Hearing*, 37 (1), 145S–154S.

- McCoy, S. L., Tun, P. A., Cox, L. C., Colangelo, M., Stewart, R. A., & Wingfield, A. (2005). Hearing loss and perceptual effort: Downstream effects on older adults' memory for speech. *The Quarterly Journal of Experimental Psychology: Human Experimental Psychology*, 58(A), 22–33.
- Nabelek, A. K., Freyaldenhoven, M.C., Tampas, J. W., Burchfiel, S.B., & Muenchen, R. A. (2006). Acceptable noise level as a predictor of hearing aid use. *J Am Acad Audiol*, 17(9), 626-39.
- Nabelek, A. K., Tucker, F. M., & Letowski, T. R. (1991). Toleration of Background Noises: Relationship With Patterns of Hearing Aid Use by Elderly Persons. *J Speech Hear Res*, 34 (3), 679-85.
- Pichora-Fuller, M. K., & Singh, G. (2006). Effects of age on auditory and cognitive processing: Implications for hearing aid fitting and audiologic rehabilitation. *Trends in Amplification*, 10, 29–59.
- Pichora-Fuller, M. K., Schneider, B. A., & Daneman, M. (1995). How young and old adults listen to and remember speech in noise. *The Journal of the Acoustical Society of America*, 97, 593–608.
- Plyler, P. N., Alworth, N. L., Rossini, T. P., & Mapes, E. K. (2011). Effects of Speech Signal Content and Speaker Gender on Acceptance of Noise in Listeners With Normal Hearing. *Int J Audiol*, 50 (4), 243-8.
- Rönnerberg, J. (2003). Cognition in the hearing impaired and deaf as a bridge between signal and dialogue: A framework and a model. *Int J Audiol*, 42 Suppl 1, S68–S76.
- Rudner, M., Lunner, T., Behrens, T., Thorén, E.S., & Rönnerberg, J. (2012). Working memory
- Sarampalis, A., Kalluri, S., Edwards, B., & Hafter, E. (2009). Objective measures of listening effort: Effects of background noise and noise reduction. *Journal of Speech, Language, and Hearing Research*, 52, 1230–1240.
- Schneider, B. A., Daneman, M., & Pichora-Fuller, M. K. (2002). Listening in aging adults: from discourse comprehension to psychoacoustics. *Can J Exp Psychol*, 56(3), 139-52.
- Singh-Manoux, A., Kivimaki, M., Glymour, M. M., Elbaz, A., Berr, C., Ebmeier, K. P., . . . Dugravot, A. (2012). Timing of onset of cognitive decline: Results from Whitehall II prospective cohort study. *BMJ*, 344, 1–8.

- Singh-Manoux, A., Kivimaki, M., Glymour, M. M., Elbaz, A., Berr, C., Ebmeier, K. P., . . .
Dugravot, A. (2012). Timing of onset of cognitive decline: Results from Whitehall II
prospective cohort study. *BMJ*, 344, 1–8.
- Tun, P. A., Benichov, J., & Wingfield, A. (2008). Effortful processing of spoken sentences in
younger and older adults: Effects of age and hearing. Paper presented at The
Cognitive Aging Conference, Atlanta, GA.
- Tun, P. A., McCoy, S., & Wingfield, A. (2009). Aging, hearing acuity, and the attentional costs
of effortful listening. *Psychology and Aging*, 24, 761–766.
- Vaughan, N., Storzbach, D., & Furukawa, I. (2006). Sequencing versus non-sequencing
working memory in understanding of rapid speech by older listeners. *J Am Acad
Audiol*, 17, 506–518.
- Wingfield, A., & Tun, P. A. (2001). Spoken language comprehension in older adults:
Interactions between sensory and cognitive change in normal aging. *Seminars in
Hearing*, 22, 287–301.

APPENDIX -1

Table representing the participant's age and ANL with the data of primary and secondary task scores of listening effort at 0 dB SNR and 4 dB SNR

SI No.	Age (Years)	ANL (dB)	Recall - 0 dB SNR (%)	Recall- 4 dB SNR (%)	Repeat - 0 dB SNR (%)	Repeat - 4 dB SNR (%)
1	51.00	-2.00	44.61	51.07	91.67	90.83
2	46.00	-7.00	43.52	48.93	56.67	87.50
3	49.00	-7.00	39.63	48.93	45.83	85.00
4	61.00	7.00	22.99	30.56	31.67	52.50
5	60.00	8.00	22.99	30.56	31.67	52.50
6	51.00	7.00	22.99	30.56	31.67	52.50
7	59.00	9.00	37.92	46.24	77.50	86.67
8	68.00	13.00	37.92	46.24	77.50	86.67
9	62.00	6.00	39.63	44.06	76.67	86.67
10	52.00	.00	31.22	35.57	54.17	70.00
11	48.00	-2.00	31.87	39.06	20.83	46.67
12	48.00	12.00	37.92	46.24	77.50	86.67
13	44.00	2.00	50.00	56.48	82.50	93.33
14	59.00	4.00	43.52	48.93	56.67	87.50
15	56.00	2.00	50.00	56.48	82.50	93.33
16	42.00	-3.00	46.78	50.00	84.17	90.83
17	55.00	5.00	39.63	44.06	76.67	86.67
18	41.00	2.00	50.00	56.48	82.50	93.33
19	62.00	4.00	39.63	44.06	76.67	86.67
20	60.00	8.00	22.99	30.56	31.67	52.50
21	59.00	3.00	43.52	48.93	56.67	87.50
22	51.00	1.00	31.22	35.57	54.17	70.00
23	54.00	3.00	39.63	48.93	45.83	85.00
24	49.00	-6.00	37.92	46.24	77.50	86.67
25	55.00	1.00	31.22	35.57	54.17	70.00
26	59.00	10.00	37.92	46.24	77.50	86.67
27	58.00	6.00	39.63	44.06	76.67	86.67
28	50.00	-4.00	53.22	53.76	88.33	94.17
29	48.00	-3.00	46.78	50.00	84.17	90.83
30	65.00	7.00	22.99	30.56	31.67	52.50
31	49.00	-7.00	43.52	48.93	56.67	87.50
32	56.00	-2.00	44.61	51.07	91.67	90.83
33	53.00	-1.00	50.00	56.48	82.50	93.33
34	60.00	2.00	31.87	39.06	20.83	46.67
35	48.00	-4.00	53.22	53.76	88.33	94.17
36	60.00	3.00	39.63	48.93	45.83	85.00
37	45.00	-6.00	43.52	48.93	56.67	87.50
38	52.00	7.00	22.99	30.56	31.67	52.50
39	54.00	-4.00	53.22	53.76	88.33	94.17
40	55.00	8.00	22.99	30.56	31.67	52.50
41	53.00	-5.00	53.22	53.76	88.33	94.17

42	45.00	-1.00	50.00	56.48	82.50	93.33
43	64.00	5.00	31.22	35.57	54.17	70.00
44	62.00	8.00	37.92	46.24	77.50	86.67
45	58.00	9.00	37.92	46.24	77.50	86.67
46	55.00	.00	50.00	56.48	82.50	93.33
47	61.00	10.00	37.92	46.24	77.50	86.67
48	50.00	-5.00	43.52	48.93	56.67	87.50
49	48.00	4.00	31.22	35.57	54.17	70.00
50	64.00	2.00	31.87	39.06	20.83	46.67
Mean	54.28	2.180	39.00	45.03	63.18	79.55
Minimum	41.00	-7.00	22.99	30.56	20.83	46.67
Maximum	68.00	13.00	53.22	56.48	91.67	94.17
Range	27.00	20.00	30.24	25.92	70.84	47.50