

# MULTIDIMENSIONAL ANALYSIS OF VOICE OF THE HEARING IMPAIRED

REGISTER No. : M. 9402

Aparna M

A DISSERTATION SUBMITTED IN FULFILMENT  
FOR THE DEGREE OF

M.Sc. [SPEECH AND HEARING]  
TO THE UNIVERSITY OF MYSORE  
MYSORE

ALL INDIA INSTITUTE OF SPEECH AND HEARING  
Mysore - 570 006

MAY 1996

*DEDICATED*

*with Love and Gratitude to  
Daddy and Mummy.*

## **CERTIFICATE**

This is to certify that the Dissertation entitled  
MULTIDIMENSIONAL ANALYSIS OF VOICE OF THE HEARING-IMPAIRED  
is the bonafide work in partial fulfilment for  
final year M.Sc, (Speech and Hearing) of the student with Reg.No. M9402.

Mysore  
May 1996

  
Dr.(Miss) S. Nikam  
Director  
All India Institute of  
Speech and Hearing'  
Mysore 570 006

## **CERTIFICATE**

This is to certify that the dissertation entitled  
MULTI-DIMENSIONAL ANALYSIS OF VOICE OF THE HEARING-IMPAIRED  
has been prepared under my supervision and guidance.

Mysore  
May 1996



**Dr. N.P. Nataraja**  
Professor and HOD  
Dept. of Speech Science  
All India Institute of  
Speech and Hearing  
Mysore 570 0006

## **DECLARATION**

This dissertation is the result of result of my own study undertaken under the guidance of Dr. N.P. Nataraja, Professor and HOD. Speech Sciences, All India Institute of Speech and Hearing, Mysore, and has not been submitted earlier at any University for any other Diploma or Degree.

Mysore  
May 1996

Reg. No.M9402

## ACKNOWLEDGEMENTS

I wish to extend my sincere gratitude to; My guide and teacher, Dr. **N. P. NATARAJA** profession and Head, department of Speech Sciences, All India Institute of Speech and Hearing, Mysore, for his personal commitment, guidance, and help, for his patience and understanding during the course of this study.

My sincere, thanks are due to Dr. **S. NIKAM, Director**, All India Institute, of Speech and Hearing, Mysore, for giving me the permission and opportunity to take up this study.

My sincere thanks to all my subjects for without which this study would'nt have been done.

**Amma and Daddy** - who have, borne, all the, pains to give me the best comforts this would can ever think of and who are responsible to make me what I am today.

**Raksha and Yasmeen** - You two are terrific and terrible. Thanks a million for putting up with me, being a source of constant support for heightening my spirits. When ever I felt low, A "Big Big Thankyou".

**Sudhir and Sohan** - thanks for your helping touches.

**Sneha and Deepti** - thanks a lot for putting me out of those bad times and making the good times even better. friends like you are like pearls - rare and precious.

*Divya, Sheeja and Shoba - who sailed in an easy kind of joy with me and shared my woes and fun together, thanks for spending your time with me for my analysis, without which I would have never got through.*

*Sridevi mam and Rajeev - thanks a lot for helping me out with the computers.*

*Pinto, I may not tell you many a time, how much you mean to me but I hope you know. You will always have a special place, in my heart. Need I say more*

*I thank all my classmates for being a moral booster and for being more fun than a barrel full of monkeys.*

*Sudhakar - thanks a lot for doing all the typing job in time..*

*Last but not the least, I thank all those people who have directly or indirectly helped me to complete this dissertation.*

**TABLE OF CONTENTS**

CHAPTERS	PAGE NO.
1. INTRODUCTION	1 - 6a
2. REVIEW OF LITERATURE	7 - 76
3. METHODOLOGY	77 - 85
4. RESULTS AND DISCUSSION	86 - 151
5. SUMMARY AND CONCLUSION	152 - 156
6. BIBLIOGRAPHY	
7. APPENDIX - A	



## LIST OF GRAPHS

- (1) Shows the mean fundamental frequency measures for normal and hearing impaired subjects for the vowel /a/.
- (2) Shows the mean fundamental frequency measures for normal and hearing impaired subjects for the vowel /i/.
- (3) Shows the mean fundamental frequency measures for normal and hearing impaired subjects for the vowel /u/.
- (4) Shows the mean intensity measures for normals and hearing impaired subjects for the vowel /a/.
- (5) Shows the mean intensity measures for normals and hearing impaired subjects for the vowel /i/.
- (6) Shows the mean intensity measures for normals and hearing impaired subjects for the vowel /u/.
- (7) Shows the mean EGG measurements for normals and hearing impaired subjects for the vowel /a/.
- (8) Shows the mean EGG measurements for normals and hearing impaired subjects for the vowel /i/.
- (9) Shows the mean EGG measurements for normals and hearing impaired subjects for the vowel /u/.
- (10) Shows the mean pitch perturbation measures for normals and hearing impaired subjects for the vowel /a/.
- (11) Shows the mean pitch perturbation measures for normals and hearing impaired subjects for the vowel /i/.
- (12) Shows the mean pitch perturbation measures for normals and hearing impaired subjects for the vowel /u/.
- (13) Shows the mean amplitude perturbation measure for normals and hearing impaired subjects for the vowel /a/.
- (14) Shows the mean amplitude perturbation measure for normals and hearing impaired subjects for the vowel /i/.
- (15) Shows the mean amplitude perturbation measure for normals and hearing impaired subjects for the vowel /u/.
- (16) Shows the mean "S" ratio for normals and hearing impaired subjects for the vowels /a/, /i/ and /u/.

## LIST OF TABLES

Page No.

Table - 1	: shows the mean and standard deviation of mean fundamental frequency of phonation in hearing impaired and normal males and females for the vowels /a/, /i/ and /u/.	90
Table - 2	: shows the t-values and significant difference frequency of phonation in hearing impaired and normal males and females for the vowels /a/, /i/ and /u/.	91
Table - 3	: shows the mean and standard deviation of maximum fundamental frequency of phonation in hearing impaired and normal males and females for the vowels /a/, /i/, and /u/.	94
Table - 4	: shows the t-values and significant difference for maximum fundamental frequency of phonation in hearing impaired and normal males and females for the vowels /a/, /i/ and /u/.	94
Table - 5	: shows the mean and standard deviation of minimum fundamental frequency of phonation in hearing impaired and normal males and females for the vowels /a/, /i/, and /u/.	95
Table - 6	: shows the t - values and significant difference in minimum and fundamental frequency of phonation in hearing impaired and normal males and females for the vowels /a/, /i/, and /u/.	96
Table - 7	: shows the mean and standard deviation for range of fundamental frequency in phonation of the vowels /a/, /i/ and /u/.	98
Table - 8	: shows the t-values and significant difference for range of fundamental frequency of phonation of the vowels /a/, /i/ and /u/.	98
Table - 9	: shows the mean and standard deviation of speed of fluctuations in hearing impaired and normal males and females for the vowels /a/, /i/ and /u/.	101
Table - 10	: shows the t-values and significant difference for the speed of fluctuations in hearing impaired and normal males and females for the vowels /a/, /i/ and /u/.	102

Table - 11:	shows the mean and standard deviation for extend of fluctuation in frequency in hearing impaired and normal males and females for the vowels /a/,/i/ and /u/.	104
Table - 12:	shows the t-values and significant difference for the extend of fluctuation in frequency in hearing impaired and normal males and females for the vowels /a/,/i/ and /u/.	105
Table - 13:	shows the mean and standard deviation of mean intensity for phonation in hearing impaired and normal males and females for the vowels /a/,/i/ and /u/.	108
Table - 14:	shows the t-values and significant difference of mean intensity for phonation in hearing impaired and normal males and females for the vowels /a/,/i/ and /u/.	108
Table - 15:	shows the mean and standard deviation of maximum intensity for phonation in hearing impaired and normal males and females for the vowels /a/,/i/ and /u/.	110
Table - 16:	shows the t-values and significant difference for maximum intensity for phonation in hearing impaired and normal males and females for the vowels /a/,/i/ and /u/.	111
Table - 17:	shows the mean and standard deviation for minimum intensity for phonation in hearing impaired and normal males and females for the vowels /a/,/i/,and /u/.	113
Table - 18:	shows the t-values and significant difference for minimum intensity for phonation hearing impaired and normal males and females for the vowels /a/,/i/ and /u/.	113
Table - 19:	shows the mean and standard deviation for range of intensity for phonation in hearing impaired and normal males and females for the vowels /a/,/i/ and /u/.	116
Table - 20:	shows the t-values and significant difference for range of intensity for phonation in hearing impaired and normal males and females for the vowels /a/,/i/ and /u/.	116
Table - 21:	shows the mean and standard deviation for the speed of fluctuation in hearing impaired and normal males and females for the vowels /a/,/i/ and /u/.	118

Table - 22:	shows the t-values and significant difference for the speed of fluctuations in intensity for phonation in hearing, impaired and normal males and females for the vowels /a/, /i/ and /u/.	119
Table - 23:	shows the mean and standard deviation for the extent of fluctuations in intensity for phonation in hearing impaired and normal males and females for the vowels /a/, /i/ and /u/.	121
Table - 24:	shows the t-values and significant difference for the extend of fluctuations in intensity for phonation in hearing impaired and normal males and females for the vowels /a/, /i/ and /u/.	121
Table - 25:	shows the mean and standard deviation for the open quotient in hearing impaired and normal males and females for the vowels /a/, /i/ and /u/.	124
Table - 26:	shows the t-values and significant difference for open quotient in hearing impaired and normal males and females for the vowel /a/, /i/ and /u/.	125
Table - 27:	shows the mean and standard deviation for the speed quotient in the hearing impaired and normal males and females for the vowels /a/, /i/ and /u/.	127
Table - 28:	shows the t-values and significant difference for the speed quotient for the hearing and normal males and females for the vowels /a/, /i/ and /u/.	128
Table - 29:	shows the mean and standard deviations for the speed index in the hearing impaired and normal males and females for the vowels /a/, /i/, and /u/.	130
Table - 30:	shows the t-values and significant difference for the speed index in the hearing impaired and normal males and females for the vowels /a/, /i/ and /u/.	131
Table - 31:	shows the mean and standard deviation of "S" ratio in hearing impaired and normal males and females for the vowels /a/, /i/ and /u/.	132
Table - 32:	shows the t-values and significant difference "S" ratio in hearing impaired and normal males and females for the vowels /a/, /i/ and /u/.	134

Table - 33:	shows the mean and standard deviation of jitter ratio in hearing impaired and normals males and females for the vowels /a/, /i/ and /u/.	136
Table - 34:	shows the T-value and significant difference for the Jitter Ratio for the hearing impaired and normal males and females for the vowels /a/, /i/ and /u/.	136
Table - 35:	shows the mean and standard deviation (SD) for Directional Perturbation factor impaired and normal male and female for the vowels /a/, /i/ and /u/.	138
Table - 36:	shows the T-value and significant difference of Directional perturbation factor Hearing Impaired and normal males and females for the vowels /a/, /i/ and /u/.	139
Table - 37:	shows the mean and Standard deviation of relative average perturbation factor for hearing impaired and normal males and females for the vowels /a/, /i/ and /u/.	141
Table - 38:	shows the t-value and significant difference for relative average perturbation factor in the hearing impaired and normal males and females for the vowels /a/, /i/ and /u/.	141
Table - 39:	shows the mean and Standard deviation of Shimmer (dB) in the hearing impaired and normal males and females for the vowels /a/, /i/ and /u/.	143
Table - 40:	shows the t-value and significant difference for Shimmer (dB) in the Hearing Impaired and normal males and females for the vowels /a/, /i/ and /u/.	144
Table - 41:	shows the mean and standard deviation (SD) for Directional Perturbation factor impaired and normal male and female for the vowels /a/, /i/ and /u/.	145
Table - 42:	shows the T-value and significant difference of Directional perturbation factor Hearing Impaired and normal males and females for the vowels /a/, /i/ and /u/.	146

Table - 43: shows mean and standard deviation (SD) for amplitude perturbation quotient in Hearing Impaired and Normal males and females for the vowels /a/, /i/ and /u/ 148

Table - 44: shows t-values and significant difference of amplitude perturbation quotient in Hearing Impaired and Normal males and females for the vowels /a/, /i/ and /u/. 148

## INTRODUCTION

"Nature as we often say, makes nothing in vain, and man is the only animal whom she has endowed with the gift of speech. And whereas mere voice is but an indication of pleasure or pain, and is therefore found in other animals, the power of speech is intended to set-forth the expedient and inexpedient, and therefore likewise the unjust. And it is a characteristic of man that he alone has any sense of good and evil, of just and unjust and the like, and the association of living beings who have this sense makes a family and a state."

ARISTOTLE, POLITICS

There are probably no more accurate gauges of a person's emotional, mental and physical well-being than voice and speech. Speech is an integral part of the total personality revealing the speaker's environment, social contrasts and education, and other aspects such as dress or grooming, are external but speech is inherent (MULGRAVE, GILMAN, PRONOVOST, 1954).

Speech is acquired through hearing and normally controlled through hearing. Hearing is important for good speech. It is the means by which sounds are learned, articulation is directed and inflection is controlled.

Hearing validates the speaker's accuracy of expression through speech. Voice bring the carrier wave of speech will be one of the aspects affected by the hearing-impairment. MONSEN, ENGETHRETSON AND VEMULA (1979) have stated that "deafness" even profound deafness does not prevent an individual from producing voice. However, hearing impairment does affect the control of voice production. When a hard of

hearing person speaks his voice calls attention to itself than to the content of speech.

The voice is normally monitored by ones auditory feedback, which is affected in the hearing-impaired individuals. GILBERT and CAMPBELL (1983) have reported that . . . . "the auditory feedback may have a potential role in modulating laryngeal phonatory output reflexively mediated through brainstem.

Most of the studies on the voice of the hearing-impaired, in the past years were based on subjective evaluation where a normal listener has been used to analyze the quality of voice. Comparatively, very few objective studies have been conducted to quantify the voice quality of the hearing-impaired.

#### AIM OF THE STUDY

The present study aims at an multidimensional analysis of voice which incorporates many parameters for the evaluation of the voice signals of the hearing-impaired children. The multidimensional approach consisted of -

- (i) The fundamental frequency measures
- (ii) The intensity measures
- (iii) ElectrogloTTographic measures and
- (iv) Pitch and amplitude perturbation measures.



HYPOTHESIS:

I. It was hypothesized that "there is no significant difference between the hearing-impaired and normal males and females in terms of parameters of voice".

Auxiliary Hypothesis:

A.1) Mean fundamental frequency:

There is no significant difference between normal and hearing-impaired males and females for mean fundamental frequency.

2) Maximum fundamental frequency:

There is no significant difference between normal and hearing-impaired males and females for maximum fundamental frequency.

3) Minimum fundamental frequency:

There is no significant difference between normal and hearing-impaired males and females for minimum fundamental frequency.

4) Range of fundamental frequency:

There is no significant difference between normal and hearing-impaired males and females for range of fundamental frequency.

5) The speed of fluctuations in frequency/sec:

There is no significant difference between normal and hearing-impaired males and females for the speed of fluctuations in frequency for one second.

6) Extent of fluctuations in frequency:

There is no significant difference between normal and hearing-impaired males and females for extent of fluctuations in frequency.

B.1) Mean Intensity:

There is no significant difference between normal and hearing-impaired males and females for mean intensity.

2) Maximum Intensity:

There is no significant difference between normal and hearing-impaired males and females for maximum intensity.

3) Minimum Intensity:

There is no significant difference between normal and hearing-impaired males and females for minimum intensity.

4) Range of intensity:

There is no significant difference between normal and hearing-impaired males and females for range of intensity.

5) The speed of fluctuations in intensity/sec:

There is no significant difference between normal and hearing-impaired males and females for the speed of fluctuations in intensity for one second.

6) Extent of fluctuations in intensity:

There is no significant difference between normal and hearing-impaired males and females for the extent of fluctuations in intensity.

II. It was hypothesised that "there is no significant difference between males and females, in terms of EGG parameters".

Auxiliary Hypothesis :

a) Open Quotient (OQ) :

There is no significant difference between normal and hearing-impaired males and females for the open quotient.

b) Speed Quotient (SQ) :

There is no significant difference between normal and hearing-impaired males and females for the speed quotient.

c) Speed Index (SI) :

There is no significant difference between normal and hearing-impaired males and females for the Speed Index.

d) "S" Ratio (SR) :

There is no significant difference between normal and hearing-impaired males and females for the "S" Ratio.

III. It was hypothesised that "there is no significant difference between normals and hearing-impaired males and females in pitch and amplitude perturbation measures".

Auxiliary Hypothesis : A. Pitch Perturbation Measures :

1) Jitter ratio (JR) :

There is no significant difference between normal and hearing-impaired males and females for the Jitter Ratio.

2) Directional perturbation factor for frequency (DPF-Freq) :

There is no significant difference between normal and hearing-impaired males and females for the Directional perturbation factor.

3) Relative Average Perturbation (Three point) (RAP) :

There is no significant difference between normal and hearing-impaired males and females for the Relative Average Perturbation.

B. Amplitude Perturbation Measures :

1) Shimmer (dB) [S(dB)] :

There is no significant difference between normal and hearing-impaired males and females for the Shimmer (dB).

2) Directional perturbation factor for amplitude (DPF-Amp) :

There is no significant difference between normal and hearing-impaired males and females for the Directional perturbation factor.

3) Amplitude Perturbation Quotient (APQ) :

There is no significant difference between normal and hearing-impaired males and females for the Amplitude Perturbation Quotient.

## REVIEW OF LITERATURE

"Man's need for communication with his fellowmen is possibly the greatest need and the fulfillment of his other needs and desires is largely dependent upon, or at the last greatly facilitated by his ability to satisfy his basic one".

(LOUISE TRACY, 1970)

Speech is normally controlled through hearing. Nowhere, is this clearly shown than in the way a baby learns\* to talk. All he needs is time. Time for added experiences, time to learn new words through hearing them and time to master vocal control by hearing his own speech (CARHART, 1970).

The speech of the deaf differs from that of normals in all regards (BLACK, 1971). In all studies of speech of the hearing-impaired, attention is drawn to the fact that, to a greater or lesser degree, the hearing-impaired individuals do not produce speech as well as those who hear (MOSEN, 1974).

MOSEN (1978) states that the knowledge of speech production abilities of hearing-impaired individuals is in many ways of potentially greater value its educators than knowledge of an individuals hearing ability.

Speech is acquired through hearing and normally controlled through hearing. From birth (even before this), every human baby shares with animals, birds, reptiles, .... an ability to respond to sound. Hearing plays a vital role in the acquisition of speech.

Production of speech requires simultaneous and coordinated use of respiratory, phonatory, articulatory and resonatory system controlled by the nervous system. This act of producing and understanding of speech is so complex that some feedback mechanisms seems likely. Auditory feedback, along with other feedback mechanisms like tactile, kinesthetic and proprioceptive, help in regulating speech production. Auditory feedback is the most important and its importance is obvious in case of delayed speech and language with hearing loss. Also when speech and language problem occurs, hearing evaluation in first recommended in diagnosis.

According to FAIRBANKS (1954), auditory feedback mechanism is an integral part of a neural servomechanism controlling voice production. One of the most viable theories in speech and hearing science describing the interaction between speech perception and production was

given by FAIRBANKS (1954). He presented his concept in the form of a model as shown in Fig.1. This model is based on operational principles rather than anatomical structures (It contains terms like "controller unit", "motor", "generator", and "sensor" rather than brain, lungs, larynx and ear respectively). The principle of closed cycle control was used in the model. Any self-regulating systems that controls its own performance to achieve a goal, is a closed cycle system. Another principle is that of negative feedback, which is basic to correcting the performance of an homeostatic system.

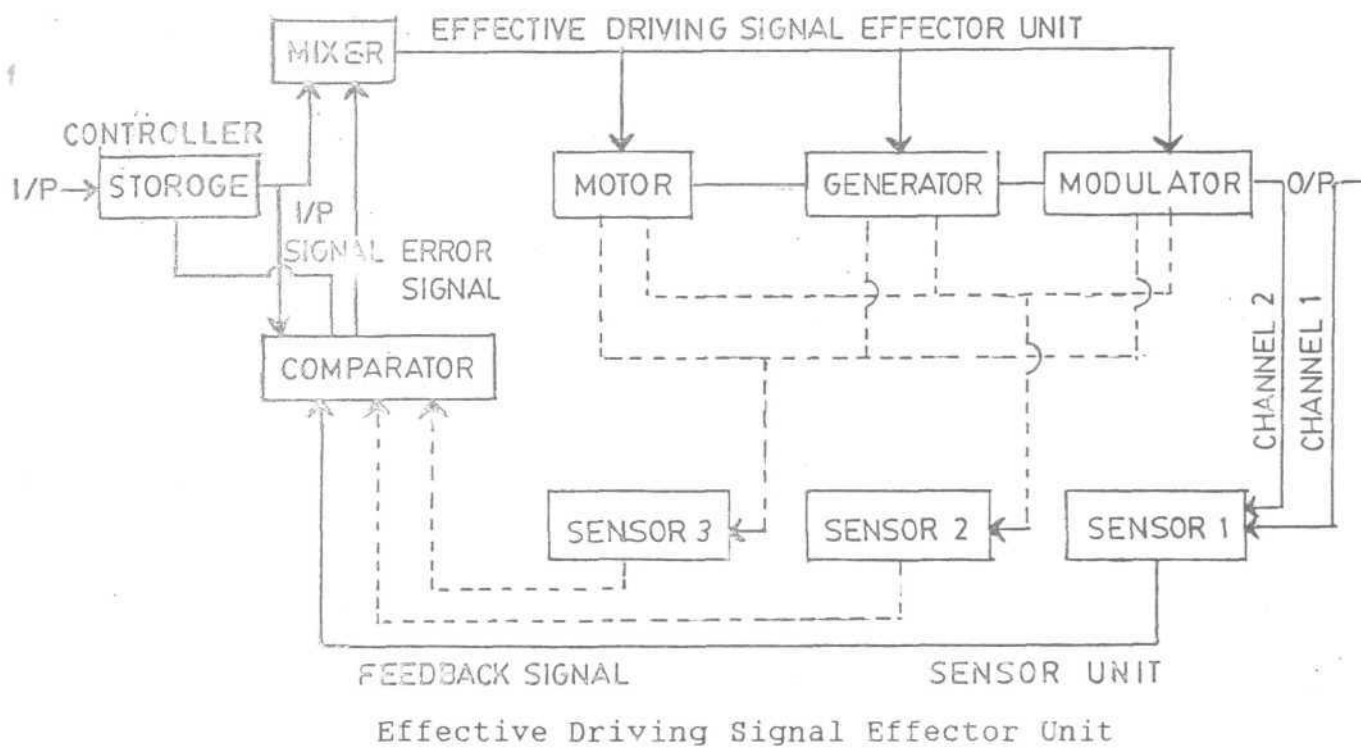

Fig.1: Model of a closed cycle control system for speaking. Input consists of instructions to the Effector unit for

production of a sound. The sensor unit feeds back output information that is compared with original instructions to determine corrections, if any, that are needed.

(FROM : Fairbanks, G., Systematic research in experimental phonetics I.A. theory of the speech mechanism as a serrosystem, JSHD, 19, 136, 1954).

Manipulation of the model reveal that mistakes like substitutions, distortions, omissions, demonstrably caused by component deficiencies.

Some of the important inferences from the model are : first, to disrupt auditory, tactile, or kinesthetic feedback would be to disrupt speech output. Second, set points (articulatory targets) to guide sound production are established initially by open cycle control when the child acquires the speech patterns of his culture. Third, once the set points that cultural norms are stabilized, child can guide future speech performance automatically by closed-cycle control. Conversely, if he stabilizes the set points that do not match cultural standards, he must be either unable or unwilling to discriminate and correct the differences between his defective performance and acceptable sound production.



Auditory mechanism provides feedback to the speaker only after the utterances has been made, so that one can only correct the error. However, audition is used to sharpen the speech sound target, and if speakers listen to themselves, to catch errors (BORDEN AND HARRIS, 1980).

The speech of the hearing-impaired individual is not a viable instrument for communication. A native listener may understand about one word in every 5 produced by a hearing-impaired, while an experienced listener's (E.g. teachers of the hearing-impaired) ability to understand the speech of the hearing-impaired seems to be clearly superior (MANGAN, 1961; MARKIDES, 1970; SMITH, 1975; and MONSEN, 1978). Acquired hearing-impairment will have little immediate effect on the intelligibility of the speech, but after a period of hearing-impairment, certain sounds deteriorate along with voice/ as one of the most important feedback instrument (i.e. hearing) is impaired.

The National Technical Institute for the Deaf, U.S.A., which carefully measured the communication skills of each of its student upon initial enrollment, has found that among its entering students 90% could use their residual hearing

to some extent but only 10% knew how to do so to their best advantage; 56% had speech that can be understood only by a trained listener, 85% were far below the average hearing college student in the ability to read or to write expressive English, and 65% in social situations in which that was the only means of receiving information (JOHNSON, 1976).

The involvement of speech due to hearing-impairment varies considerably according to the type, severity, age of onset of hearing impairment, and many such factors. The speech of a person with a hearing-impairment before learning to speak (pre-lingually), will present defects in voice and articulation. A person with acquired hearing-impairment (post-lingually), is likely to present defects of voice, but no appreciable difficulty with articulation. If the impairment of hearing is sufficiently severe, both voice and articulatory difficulties are likely. Therefore, hearing-impairment can be said to have causal relationship to certain types of voice and articulation disorders (EISENBERG, KASTEIN and SCHNEIDERMAN, 1958).

The investigators have described the voice quality of the hearing-impaired as monotonous, lacking accent, rhythm,

poor resonance, poor carrying power and unnatural qualities (tense, breathy, harsh, throaty etc.). CALVERT (1962) has identified more than fifty-two different adjectives to describe the quality of the voice of the hearing-impaired. Voice quality deviations have been found to accompany hearing losses of 45 dB HL and greater (SILVERMAN, 1960), with the great degree of abnormality of speech being greater in persons with more severe losses (HUDGINS and NUMBERS, 1942).

Descriptions of the speech of hearing-impaired individuals have, for the most part been based on perceptual evaluations or subjective evaluations. Studies of HUDGINS and NUMBERS (1942), MANGAN (1961), NOBER (1967), MARKIDES (1970), SMITH (1975), McGARR (1978) and GEFNER (1980), have described the speech of the hearing-impaired individuals by using a normal listener as an analytical tool. They used the terms such as hypernasality, hyponasality, gross misarticulations, faulty stress and faulty intonation to describe the speech of hearing-impaired. These confusions may be the results of subjective methods used in the past to evaluate the speech of the hearing-impaired individuals.

In a clinical set-up, clinician listens to the speech of the hearing-impaired individuals and judge it as segmental errors, such as omission of consonants, substitution of one phoneme for another moderate distortion to severe distortions and insertion of adventitious sounds or as suprasegmental errors, such as improper intonations, improper rhythm and other prosodic features.

Studies also have attempted to measure the overall intelligibility of hearing-impaired individuals (HUDGINS and NUMBERS, 1942; MANGAN, 1961; MARKIDES, 1970; SMITH, 1975; MONSON, 1978; McGARR, 1981; and RAVISHANKAR, 1985.

However, according to MONSEN (1976 b), the usefulness of the normal listener as an analytical tool has limitations

- (i) some sounds that the hearing-impaired individual may produce are simply not classifiable as a variant of any phoneme.
- (ii) Since each phoneme is signaled by a variety of cues, confusion matrices do not tell us the exact cause of the confusion.

These observations underline the importance of objective measurements of different parameters of speech. Several studies have employed objective measurements to describe the speech of the hearing-impaired.

With the advent of high technology it is now possible to develop a great variety of training displays designed to convey information about many aspects of speech. Acoustic analysis has been considered as the basic tool in the investigation of speech of the hearing-impaired. Analysis of acoustic parameters such as fundamental frequency, intensity, waveform, or acoustic spectrum and their time related variations have been considered to be useful in drawing a voice profile.

HIRANO (1981) has pointed out that the acoustic analysis of voice signal may be one of the most attractive methods of assessing phonatory function or laryngeal pathology because it is non-invasive and provides objective and quantitative data, many acoustic parameters, derived by various methods have been reported to be useful in differentiating between the pathological and the normal voice (CRYSTAL and JACKSON, 1970; VON LEDEN and KOIKAN,

1970; KOIKE, 1973; NATARAJA, 1986; and PINTO AND TITZE, 1990).

The acoustical parameters can be divided into fundamental frequency measurements, intensity measurements and spectral measurements.

#### A. Fundamental Frequency Related Measurements

- (i) Fundamental frequency in phonation
- (ii) Fundamental frequency in speech
- (iii) Fundamental frequency in reading
- (iv) Frequency range in phonation
- (v) Frequency range in speech
- (vi) Jitter (pitch perturbation)
- (vii) Extent of fluctuation in fundamental frequency in phonation
- (viii) Speed of fluctuation in fundamental frequency

#### B. Intensity Related Measurements

- (i) Intensity range in phonation
- (ii) Intensity range in speech
- (iii) Shimmer (amplitude perturbation)
- (iv) Extent of fluctuation in intensity
- (v) Speed of fluctuation in intensity

#### c. Spectral Parameters

- (i) Alpha ratio : Ratio of intensities between 0-1 KHz and above 1-5 KHz
- (ii) Beta ratio : Ratio of intensities of harmonics and the noise is 2-3 KHz
- (iii) Frequency of first formant.

HANSON, GARRATT and WARD (1983) suggested that majority of phonatory dysfunctions are associated with abnormal and irregular vibrations of the vocal folds. These irregular vibrations leads to the generation of random acoustic energy i.e. noise, fundamental frequency and intensity variations. This random energy and aperiodicity of fundamental frequency is perceived by the human ears as hoarseness. The aerodynamic parameters measure the respiratory airflow. They do not provide adequate information regarding the voice and its production. Whereas spectral parameters are more appropriate in quantifying the phonatory functions. However, spectral measurements are complex to obtain and the instrumentation is highly sophisticated and expensive. Hence, for clinical purposes these measurements are not desirable. Although intensity related measurements are useful in describing the phonatory function and are relatively easy to measure, the values are highly variable. So, they have reduced reliability. Among the various intensity related measurement, the measurements of intensity variation are very useful in early identification and assessment of severity of voice disorder. They are :

- (i) Amplitude perturbation (Shimmer)
- (ii) Extent of fluctuation in intensity
- (iii) Speech of fluctuation in intensity

A few studies of these acoustic parameters have been carried out for the normals in the Indian population (KUSHAL RAJ, 1984; RASHMI, 1985; RAJANIKANTH, 1986).

#### FUNDAMENTAL FREQUENCY

The fundamental frequency often loosely called the pitch of the voiced speech sounds varies considerably in the speech of a given speaker and the average or characteristic fundamental frequency varies over speakers.

Of the three major attributes of voice the underlying basis of speech, namely pitch, loudness and quality, "... both quality and loudness of voice are mainly dependent upon the frequency of vibration. Hence it seems apparent that frequency is an important parameter of voice" (ANDERSON, 1961).

Pitch is the psychophysical correlate of frequency. Although pitch is often defined in terms of puretones, it is clear that noise and other aperiodic sounds have more or less definite pitches. The pitch of a complex tone, according to STEVENS and DAVIS (1935) depends upon the



frequency of its dominant component, that is, the fundamental frequency in a complex tone. PLOMP (1967) states that even in a complex tone, where the fundamental frequency is absent or weak, the ear is capable of perceiving the fundamental frequency based on periodicity of pitch.

EMRICKSON (1959) is of the opinion that the vocal folds are the ultimate determiners of pitch. The same general structure of the folds seems to determine the range of frequencies that one produces. The factors determining the frequency of vibration of any vibrator are mass, length and tension of the vibrator. Thus, mass length and tension of the vocal cords determine the fundamental frequency of voice.

There are various objective methods to evaluate the Fundamental Frequency of the Vocal Cords. Stroboscopic Procedures, High Speed Cinematography, Electrolottography, Ultrasonic Recordings, Stroboscopic Laminagraphy (STROL), Cepstrum Pitch Detection; Digit Pitch, the 3M Plastiform Magnetic Tape Viewer, Spectrography, Pitch computer, the High Resolution Signal Analyzer Frequency Meter, Visipitch,

Vocal II, Computer with Speech Interface unit and Software and other.

Voice of a new born has been found to be around 400 Hz (GROTZMANN and PLATEAU, 1905, INDIRA, 1982). The fundamental frequency drops slightly during the first three weeks or so, but then increases until about the fourth month of life, after which it stabilizes over a period of five months.

The fundamental frequency values are distinguished by sex only after the age of eleven years, although small sex difference might occur before that age (KENT, 1976).

Studies on Indian population have shown that, in males, the lowering in fundamental frequency is gradual till the age of 10 years, after which there is a sudden marked lowering in the fundamental frequency, which is attributed to the changes in the vocal apparatus at puberty. In the case of females, a gradual lowering of fundamental frequency is seen (GEORGE, 1973; USHA, 1979; GOPAL, 1980; KUSHAL RAJ, 1983).

Average fundamental frequency decreases with increasing age until adulthood for both males and females. The average drop of  $F_0$  in females is roughly 75 Hz (from about 270-300 Hz to about 200-225 Hz) from prepubescence to adulthood. For males the drop over the same period is likely to be about 150 Hz (275-300 Hz to 100-150 Hz) about 100 Hz of which may occur abruptly as a result of the adolescent voice break (CURRY, 1940; FAIRBANKS, 1940).

Several investigators have noted that deaf speakers have a relatively high average pitch or to speak in falsetto voice (ANGELOCCI, KOPP and HOLBROOK, 1964; BOONE, 1966; ENGLEBERG, 1962; MARTONY, 1968). There is some evidence that this problem is greater among the teen-agers than in for preadolescent age group and that it is particularly troublesome for adolescent boys (BOONE, 1966). ANGELOCCI, KOPP and HOLBROOK (1964) suggest not only that fundamental frequency of deaf are higher than that of hearing-impaired speakers on the average, but also that the average fundamental frequency for different speakers spans of wider range.

Deaf speakers often tend to vary the pitch much less than do hearing speakers and the resulting speech has been

described as flat or monotone (CALVERT, 1962; HOOD, 1966; MORTON, 1968).

The study of fundamental frequency has important clinical implications. COOPER (1974) has used spectrographic analysis, as a clinical tool to describe and compare the  $F_0$  and hoarseness in dysphonic patients before and after vocal rehabilitation. JAYARAM (1975) found a significant difference in habitual frequency measures between normals and dysphonics.

RAJANIKANTHA (1986) studied the fundamental frequency of phonation and found a significant difference in fundamental frequency for the two groups was seen between males and females. A significant difference between the two sexes was also seen. The  $F_0$  for vowel /a/ was lowest when compared with /i/ and /u/, which varied indifferent age groups for both males and females.

There are also a few Indian studies done on the acoustical parameters in the hearing-impaired population (by MANJULA, 1986; RAJANIKANT, 1986; ARUN, 1995 and OTHERS).

Hence, there is a need for the study of acoustic parameters in the speech of the hearing-impaired. This will not only help in understanding the speech of hearing-impaired but also helps in deciding the goals in therapy and increasing the effectiveness of therapy.

McCLUMPHA (1966) showed that velopharyngeal function in hearing-impaired speakers ranged from no closure to normal closure on the speech samples studied. GILBERT (1975) reported a variety of airflow patterns and air pressure patterns were identified as being characteristic of speech of hearing-impaired individuals. HOLBROOK and CROWFORS (1970) AND BOONE (1966) found that hearing-impaired individuals exhibited higher than normal fundamental frequency values, while THORNTON (1964) reported essentially normal speaking frequencies for hearing-impaired speakers.

There have been a few attempts to describe the speech of the hearing-impaired individuals acoustically using the sound spectrograph. Acoustic analysis of hearing-impaired speech permits a finer a grained considerations of some aspects of both correct and incorrect productions that would be possible using methods applied in the subjective procedures (OSBERGER and McGARR, 1982).

CALVERT (1962) found that the mispronunciation of voiced and voiceless stop consonants was principally a durational error, and that deaf speakers distorted systematic differences of duration, associated with the phonetic environment.

ANGELOCCI, KOPP and HOLBROOK (1964) and MONSEN (1976 c) showed that the vowel formants of deaf individuals tend to be more centralized than those of normal speakers.

MONSON (1974) from his study of durational aspects of vowel production of deaf individuals concluded that the vowel production characteristics of the deaf subjects account in part for the low intelligibility of consonants in the speech of the deaf individuals.

MONSEN (1976 d) showed that in the speech of the hearing-impaired subjects the second formant transitions may be reduced both in time and frequency. At the transition onset, the second formant was found to be near to its eventual target frequency than in the speech of the normal subjects.

GILBERT (1978) found differences in voice onset time (VOT) between the hearing-impaired and normal individuals. Perhaps the most detailed study in this area has been conducted by MONSEN (1976 a). MONSEN (1976 a) through spectrographic analysis of the production of English stop consonants concluded that the deaf child does not simply make errors in speaking, but instead realizes sounds in accordance with a deviant phonological system.

MONSEN (1979) examined mean fundamental frequency, duration, mean period to period changes in intensity and fundamental frequency, spectral energy ratio above and below 100 Hz and intonation contour in the speech of the hearing-impaired individuals. The type of intonation contour appeared to be the most important characteristic separating the better from the poorer speakers. The hearing-impaired subjects produced four different types of deviant intonation contours.

#### FUNDAMENTAL FREQUENCY IN SPEECH

In evaluation of the  $F_0$  in phonation, may not represent the true fundamental frequency used by an individual in

speech. Hence, it becomes important to evaluate the speaking fundamental frequency. The fundamental frequency in speech is estimated subjectively by matching or it is determined objectively with a pitch meter or digipitch. For more precise measurement, Fo histograms are obtained with the aid of a computer.

Many investigators have studied the speaking fundamental frequency as a function of age and in various pathological conditions. The age dependent variations of speaking fundamental frequency decreases with age upto the end of adolescence. A marked lowering takes place during adolescence in men.

GILBERT and CAMPBELL (1980) studied the speaking fundamental frequency in three groups (4-6 years, 8-10 years, and 16-25 years) of hearing-impaired individuals, and reported that the values were higher in the hearing-impaired group when compared to values reported in the literature for normally hearing individuals of the same age and sex.

MURRY (1978) studying the fundamental frequency in speech characteristics of 4 groups of subjects, namely vocal



fold paralysis, benign mass lesion, cancer of the larynx and normals noted that the parameters of mean fundamental frequency in speech failed to separate the normals from the three groups of pathologic subjects.

In a parallel study, HURRY and DOHERTY (1980) reported that along with other voice production measures such as directional and magnitudinal perturbation, the fundamental frequency in speech improved the discriminate function between normal voices and malignancy of the larynx.

SAWASHIMA (1968) reported a raise in mean fundamental frequency in speech in cases of sulcus vocalis and a fall in mean fundamental frequency in speech in cases of polypoid vocal folds and virilism. Very high mean fundamental frequency in speech values results from disturbances of mutation in males. At present mean  $F_0$  in speech is measured as a clinical test value (HIRANO, 1981).

NATARAJA and JAGADESH (1984) measured fundamental frequency in phonation, reading, speaking and singing and also the optimum frequency in thirty normal males and thirty normal females. They observed that the fundamental frequency

increased from phonation to singing with speaking and reading in between. Hence, fundamental frequency has to be measured under different conditions in evaluation of voice disorders i.e., it may not be enough if one considers are condition to determine the mean fundamental frequency used by the case for evaluation of voice.

BOHME and HECKER (1970) reported the age dependent variations of mean speaking fundamental frequency in normals indicates that mean speaking fundamental decreases with age upto the end of adolescence. A marked lowering takes place during adolescence in mean. In advanced age, it becomes higher in becomes higher in men but is slightly lower in women.

A study of mean modal fundamental frequency in reading in 200 young black adults between 18-29 years, showed lower mean modal fundamental frequencies (i.e. 110.15 Hz in males and 193.10 Hz in females) when compared to similar white population studied by FITCH and HOLBROOK (1970).

HOLLIEN AND SHIPP (1972) present data on the man speaking fundamental frequency in 175 males talker ranging

in age from 29-89 years mean frequency levels by age decade show a progressive lowering of speaking fundamental frequency from age 20-40 with a rise in level from age 60 through the 80s. In the 20-29 years range the mean frequency is reported to be 120 Hz. This value (120 Hz) obtained for the 20-29 year olds agrees.

- (i) Best with the data reported by HANLEY (N=27, median frequency = 128 Hz) for a population of about the same size and age.
- (ii) Reasonably well for a larger and younger group studied by HOLLEN and JACKSON (N=157, Mean frequency = 128 Hz, Mean age = 21 years), and
- (iii) Poorest (but still not in conflict) with studies by PROVROUEST (N=6, mean frequency = 132 Hz) and HILHOUR (N=24, Mean frequency = 132 Hz).

The results indicated by MICHEL, HOLLIN and MOORE (1965), studying the speaking fundamental frequency characteristics of 15-, 16-, and 17- years old girls, in order to determine the age at which adult female speaking fundamental frequencies are established, show that females attain adult speaking fundamental frequency by 15 years of age.

RASHMI (1985) in her study reports that there is very little change in the speaking fundamental frequency (SFF) as a function of age in males upto the age of 14 years at which age a sudden decrease in SFF in the females with increase in age.

In the hearing-impaired speakers, due to lack of proper feedback, an inability to control the SFF is seen. MECKFESSEL (1964) and THORNTON (1964) reported SFF data for 7- and 8- years old hearing-impaired speakers that were higher than values for normally hearing speakers.

MECKFESSEL (1964) and THORNTON (1964) reported SFF values in post-puberscent hearing-impaired males that were higher than those obtained for normally hearing post-puberscent males, while values obtained by GREEN (1356) were similar to those for normal hearing males. For hearing-impaired females, GREEN (1956) reported higher values than for normal hearing females, while ERMOVICK (1965) and GRUENEWALD (1966) reported values that were similar.

Thus, the review of literature shows that the measurement of Fo both in phonation and speaking is

important in assessing the neuromuscular functioning and diagnosis and treatment of voice disorders. However, the present study is also considering the measurement of fundamental frequency in phonation as it would be helpful in assessing and in therapy.

A discrepancy, then exists as to whether or not there are differences in speaking fundamental frequency values between normal hearing and hearing-impaired speakers of the same age.

Another factor that may influence speaking fundamental frequency is the method of communication. Oral versus total communication. GREEN (1956) studied the effects of these two methods of communication on 8-12 years and 6-21 years old speakers and found that the differences between the two schools were not statistically significant. But the study by GILBERT and CAMPBELL (1980) in their population of children between 4-6 years and 8-10 years showed that the hearing-impaired children from the oral school for the deaf had speaking fundamental frequencies which were closer to values exhibited by normal hearing speakers than that in the total communication school as shown below:

	Mean speaking 4-6 years	fundamental frequency 8-10 years
Normal hearing speakers	280.62	264.83
Hearing-impaired (Oral school)	316.30	281.21
Hearing-impaired (Total communication school)	351.85	362.58

The difference between schools may be explained in part by the work of POLLACK (1964). The hearing-impaired child trained in total communication expressed himself/herself through signs, finger spelling and speech. POLLACK (1964) stated that when conflicting or competing "attention tendencies" are present (attending to correct "production of signs and finger spelling, as well as voice production, one "tendency" receives most of the attention at the expense of the others. It may be assumed therefore that the child's concentration on the correct production of signs and finger spelling detracts from his or her ability to self-monitor his or her voice through the aid of residual hearing. At an oral school, there is greater emphasis on speech training than at a total communication school.

RAJANIKANTH (1986) studied the speaking fundamental frequency and found a significant difference between males

and females and also between the two age groups as a function of age. When compared with the normals, the hearing-impaired in general showed a higher speaking fundamental frequency.

#### FREQUENCY RANGE IN PHONATION AND SPEECH

Humans are capable of producing a wide variety of acoustic signals. The patterned variations of pitch over linguistic units of differing length (syllables, words, phrases) yield in critical prosodic features namely intonation (FREEMAN, 1982).

Variations in fundamental frequency and the extent of range used also relate to the intent of the speaker (FAIRBANKS and PRONOVAST, 1939). More specifically, the spread of frequency range used corresponds to the mood of the speaker, that is, as SKINNER (1936) reports, cheerful animated speech exhibits greater range than serious, thoughtful speech.

HUDSON and HOLBROOK (1981) studied the fundamental vocal frequency range in reading, in a group of young black adults, age range from 18-29 years. Their results

a mean range from 81.95 - 158.50 Hz in males and from 139.05 Hz to 266.10Hz in females. Compared to a similar white population studied by FITCH and HOLBROOK (1970), the black population had greater mean frequency ranges. FITCH'S (1970) white subjects showed a greater range below the mean model than above. This behaviour was reversed for the black subjects. HUDSON (1981) pointed out that such patterns of vocal behaviour may be important clues which alert the listener to the speaker's racial identity.

During speech, using a normal phonatory, mechanism, a certain degree of variability in frequency is expected and indeed is necessary. Too limited or too wide variation in frequency is an indication of abnormal functioning of the vocal system. However, even if an individual has frequency range within normal limits he may still use little inflection during speech. An octave and a half in males and two octaves in females is considered normal.

NATARAJA (1986) found that the frequency range did not change much with age i.e. in the age range 16-45 years. He also found that females showed a greater frequency range than males in both phonation and speech. GOPAL (1986) from a study of normal males from 16-65 yers, reported slightly



lower frequency range in speech. Thus, review indicates that it is important to have extensive data on the pitch variations, before it can be applied to the clinical population.

HANSON, GARRATT and WARD (1983), suggested that majority of phonatory dysfunctions are associated with abnormal and irregular vibrations lead to the generation of random acoustic energy, i.e. noise, fundamental frequency and intensity variations. This random energy and a periodicity of  $F_0$  is perceived by human ears as hoarseness. Hence, the spectral, intensity and  $F_0$  parameters are more appropriate in quantifying phonatory dysfunctions. The frequency related parameters are the most rugged and sensitive in detecting anatomical and sensitive in detecting anatomical and physiological changes in the larynx (HANSON, GARRATT and WARD, 1983).

Cycle to cycle variation in fundamental frequency is called pitch perturbation or jitter. Presence of small amount of perturbation in normal voice has been know (MOORE, VON LEDEN, 1958; VON LEDEN et al. 1960). A periodic

laryngeal vibratory pattern have been related to the abnormal voice (CARHART, 1983, 1941, BOWLER, 1964).

BAER (1980) explains vocal jitter as inherent to the method of muscle excitation based on the neuromuscular model of the fundamental frequency and muscle physiology. He has tested the model using EMG from cricothyroid muscle and voice signals, and claims neuromuscular activities as the major contributor for the occurrence of perturbation.

WYKE (1969), SORENSEN, HORII and LEONARD (1980) have reported the possible role of laryngeal mucosal reflex mechanism in  $F_0$  perturbation. This view of possible role of laryngeal mucosal reflex findings gets support from the studies where deprivation or reduction of afferent information from the larynx induce by anesthetizing the laryngeal muscles. This might reduce the laryngeal mucosal reflex (WYKE, 1967, 1969) and in turn increase the jitter size in sustained phonation (SORENSEN et al. 1970).

HEIBERGER and HORII (1982) also say that mucosal receptors in the larynx are important in maintaining the laryngeal tension particularly in sustaining high frequency

tone. They stated that "the physiological interpretation of Jitter in sustained phonation should probably include both physical and structural variations and myoneurological variations during phonation.

A number of high speed laryngoscopic motion pictures reveal that the laryngeal structures (the vocal folds) were not totally symmetries. Different amounts of mucous accumulation on the surface of the vocal folds during vibration. In addition turbulent airflow at the glottis also causes some perturbation. Limitations of laryngeal servo mechanism through the articulation myolitic mucosal reflex system (GOULD and OKAMURA, 1974; WYKE, 1967) may also introduce small perturbations in laryngeal muscle tone. Even without consideration of reflex mechanism, the laryngeal muscle tone have inherent perturbation due to the time staggered activities, which exist in any voluntary muscle contractions.

VONLEDEN et. al (1960) reported that the most frequent observation in the pathological conditions it that there is a strong tendency for frequency and rapid changes in the regularity of vibratory pattern. The variations in the vibratory pattern are accompanied by transient pressure

changes across the glottis which are reflected acoustically in disturbance of the fundamental frequency and amplitude patterns. Hence, pitch perturbation and amplitude perturbation values are greater in pathological conditions.

WILCOX (1978), WILCOX and HORII (1980) reported that a greater magnitude of jitter occurs with advancing age which they attributed to the reduced sensory contribution from laryngeal mechanoreceptor. However, these changes in voice with age may also be due to physical changes associated with respiratory and articulatory mechanism. These perturbation are related parameters in pitch and amplitude can be measured. There are different algorithms for the measurement of pitch perturbations. Some of them are -

(i) Absolute Jitter/sec/or Jita

$$\text{Jita} = \frac{1}{N-1} \sum_{i=1}^{N-1} \left( T_o^{(i)} - T_o^{(i+1)} \right)$$

Where,  $T_o^{(i)}$ ,  $i=1, 2, \dots, N$  - extracted pitch period data.  
 $M=Per$ , No.of extracted pitch periods.

(ii) Jitter percent or Jitt

$$\text{Jitt} = \frac{\frac{1}{N-1} \sum_{i=1}^{N-1} \left( T_o^{(i)} - T_o^{(i+1)} \right)}{\frac{1}{N} \sum_{i=1}^N T_o^{(i)}}$$

Where,  $T_o^{(i)}$ ,  $i=1, 2, \dots, N$  - extracted pitch period data  
 $N=per$ , No. of extracted pitch periods.

(iii) Pitch Period Perturbation Quotient (%)

$$PPQ = \frac{\frac{1}{N-4} \sum_{i=1}^{N-4} \frac{1}{5} \sum_{r=0}^4 \left( \frac{T_o^{(1+r)}}{T_o^{(i+2)}} - 1 \right)}{\frac{1}{N} \sum_{i=1}^N \frac{T_o^{(i)}}{T_o}}$$

(iv) Smoothed Pitch Period Perturbation Quotation (%)

$$SPPQ = \frac{\frac{1}{N-Sf+1} \sum_{i=1}^{N-Sf+1} \frac{1}{Sf} \sum_{r=0}^{Sf-1} \left( \frac{T_o^{(i+r)}}{T_o^{(i+m)}} - 1 \right)}{\frac{1}{N} \sum_{i=1}^N \frac{T_o^{(i)}}{T_o}}$$

Where,  $T_o^{(i)}$ ,  $i=1, 2, \dots, N$  extracted pitch period data  $N=PER$ .  
 No. of extracted pitch periods.

(v) Co-efficient of  $F_o$  variation (%)

$$VFO = \frac{\sigma}{F_o} = \frac{\sqrt{\frac{1}{N} \sum_{i=1}^N \left( \frac{F_o^{(i)}}{F_o} - \frac{1}{N} \sum_{i=1}^N \frac{F_o^{(i)}}{F_o} \right)^2}}{\frac{1}{N} \sum_{i=1}^N \frac{F_o^{(i)}}{F_o}}$$

Where,  $Fo = \frac{1}{N} \sum_{i=1}^N Fo^{(i)}$ , and

$$Fo^{(i)} = \frac{1}{To^{(i)}} - \text{Period to period } Fo \text{ value}$$

$To^{(i)}$ ,  $i=1, 2, \dots, N$  extracted pitch period.

$N=per$ , No.of extracted pitch periods.

(vi) Relative Average Perturbation (%)

$$RAP = \frac{\frac{1}{N-2} \sum_{i=2}^{N-1} \left( \frac{To^{(i-1)} + To^{(i)} + To^{(i+1)}}{3} - To^{(i)} \right)}{\frac{1}{N} \sum_{i=1}^N To^{(i)}}$$

Where,  $To^{(i)}$ ,  $i=1, 2, \dots, N$ , extracted pitch period data.

$N = PER$  No.of extracted pitch periods.

LIEBERMAN (1963) found that pitch perturbation in normal voice never exceeded 5 msec in the steady state portion of sustained vowels. Similar variations in fundamental periodicity of the acoustic wave form have been measured by FAIRBANKS (1940).

IWATA and VONLEDEN (1970) reported that the 95% confidence limits of pitch perturbation in normal subjects ranged from -0.19 to +0.2 msec. Several factors have been

found to effect the values of jitter such as age, sex, vowel produced, frequency and intensities.

HIGGINS and SAXMAN (1989) reported higher values of frequency perturbation in males than females. Gender difference may exist not only in magnitude, but also in the variability of frequency perturbation. SORENSON and HORII (1983) reported that normal female speakers have more jitter than normal male speakers. This result contradicts the findings of HIGGINS and SAXMAN (1989). ROBERT and BAKEN (1984) reported higher jitter values in males and females. They attributed this difference to Fo. When the Fo increases the percentage of jitter values decreases.

ZEMBLIN (1962) has reported greater jitter values for /a/ than /i/ and /u/ showed lowest value. This result is supported by the studies of WILCOX (1978) and LINVILLE and KARABIC (1987). JOHNSON and MICHEL (1969) reported greater jitter value of high vowels than vowels in 12 English vowels. WILCOX and HORII (1980) reported that /u/ was associated with significantly smaller jitter (0.55%) than /a/ and /i/ (0.68% and 0.69% respectively).

SORENSEN and HORII (1983) studied the vocal jitter during sustained phonation of /a/, /i/ and /u/ vowels. The result showed that jitter values were low for /a/ with 0.71% high for /i/ with 0.96% and intermediate for /u/ with 0.86%. LINVILLE and KORABIC (1987) have found that intraspeaker variability tend to be greatest on the low vowel /a/, with less variability on high vowels /i/ and /u/. The values of the measures of jitter are dependent upon the vowels produced during sustained phonation and also the frequency and intensity level of the phonatory sample and also the type of phonatory imitation and termination.

RAMIG (1980) postulated that jitter values should increase when subjects are asked to phonate at a specific intensity, and or as long as possible.

The extent and speed of fluctuation in frequency and intensity are also one of the fundamental frequency and intensity variation measurements. The fluctuations in frequency and intensity in phonation sample may indicate the physiological (neuro muscular) or pathological changes in the vocal mechanism.



KIM, KAKITA and HIRANO (1982) have analyzed Japanese /u/, /o/, /e/, /a/ and /i/ vowels. This was earlier analyzed by Imaizumi (1980) using the spectrography in 10 voices of patients with recurrent laryngeal nerve paralysis and 10 normals to obtain the following acoustic parameters.

The acoustic parameters obtained from the spectrographs were  
(i) Extent of fluctuation in fundamental frequency

The extent of fluctuation as defined as the percent score of the ratio of the peak to peak value of fluctuation ( $\Delta F_0$ ) to the mean fundamental frequency ( $F_0$ ).

(ii) Speed of fluctuation in fundamental frequency

This has been defined as the peak to peak value in decibels measured on an average amplitude display.

(iii) Extent of fluctuation in intensity

This has been defined as the peak to peak value in decibels measured on an average amplitude display.

(iv) Speed of fluctuation in intensity

This was defined as the number of positive peaks on an amplitude display within 1 sec. Peaks of 3 dB or greater from adjacent though have been counted.

The results of this study have indicated that among the acoustic parameters studied significant differences were found between the control and the diseased group in terms of fluctuation of fundamental frequency. VANAJA (1986), THARMAR (1991) and SURESH (1991) have reported that as the age increases there was increase in fluctuations in frequency and intensity of phonation and this difference was more marked in females.

NATARAJA (1986) has found that speed of fluctuation in fundamental frequency and extent of fluctuation in intensity parameters were sufficient to differentiate the dysphonics from the normals. He has given definition for extent and speed of fluctuation in fundamental frequency and intensity. They are mentioned below:

The extent of fluctuation in frequency was defined as the mean of fluctuation in fundamental frequency in phonation of one second.

The fluctuations in frequency was defined as variations + 3 Hz and beyond in fundamental frequency.

The speed of fluctuation in frequency was defined on the number of fluctuations in fundamental frequency a phonation of one second.

The extent of fluctuation in intensity was defined on the means of fluctuations in intensity in a phonation of one second.

Fluctuation in intensity was defined as variations + 3dB and beyond in intensity.

The speed of fluctuation in intensity was defined as the number of fluctuations in intensity in phonation of one second.

Cycle to cycle variation of amplitude is called intensity perturbation or shimmer. These perturbations in amplitude can be measured using several parameters. These are different algorithm for measurement of amplitude perturbations. Some of them are given below :

(i) Shimmer in dB/or Sh dB

$$\text{Sh dB} = \frac{1}{N-1} \sum_{i=1}^{N-1} 20 \log \left[ \frac{A^{(i+1)}}{A^{(i)}} \right]$$

Where,  $A^{(i)}$ ,  $i=1, 2, \dots, N$  - extracted peak to peak amplitude data

$N$  - No.of extracted impulses.

(ii) Shimmer Percent (%) or Shim

$$\text{Shim} = \frac{\frac{1}{N-1} \sum_{i=1}^{N-1} A^{(i)} - A^{(i+1)}}{\frac{1}{N-1} \sum_{i=1}^N A^{(i)}}$$

Where,  $A^{(i)}$ ,  $i=1, 2, \dots, N$  - extracted peak to peak amplitude data

$N$  - No.of extracted impulses.

(iii) Amplitude Perturbation Quotient (%) - APQ

$$\text{APQ} = \frac{\frac{1}{N-4} \sum_{i=1}^{N-4} \frac{1}{5} \sum_{r=0}^4 A^{(i+r)} - A^{(i+2)}}{\dots}$$

Where,  $A^{(i)}$ ,  $i=1, 2, \dots, N$  - extracted peak to peak amplitude data

$N$  - No.of extracted impulses.

(iv) Smoothed Amplitude Perturbation Quotient (%) (SAPQ)

$$SAPQ = \frac{\frac{1}{N-Sf+1} \sum_{i=1}^{N-Sf+1} \frac{1}{Sf} \sum_{r=0}^{Sf-1} A^{(i+r)} A^{(i+m)}}{\frac{1}{N} \sum_{i=1}^N A^{(i)}}$$

Where,  $A^{(i)}$ ,  $i=1, 2, \dots, N$  - extracted peak to peak amplitude data

$N$  - No.of extracted impulses

$Sf$  - Smoothing factor

(v) Co-efficient of Amplitude Variation (%) VAM

$$VAM = \frac{\frac{1}{N} \sum_{i=1}^N \left( \frac{1}{N} \sum_{i=1}^N A^{(i)} - A^{(i)2} \right)}{\frac{1}{N} \sum_{i=1}^N A^{(i)}}$$

Where,  $A^{(i)}$ ,  $i=1, 2, \dots, N$  extracted peak to peak amplitude data

$N$  - No.of extracted impulses

Shimmer in any given voice is dependent at least upon the modal frequency level, the total frequency range and the SPL relative to each individual voice. MICHEL and WENDAHAL (1971) and RAMIG (1980) postulated that shimmer values should increase when subjects are asked to phonate at a specific intensity and/or as long as possible.

KITAJIMA and GOULD (1976) studied vocal shimmer during sustained phonation in normal subjects and patients with laryngeal polyps. They found the value of vocal shimmer ranging from 0.04 dB to 0.21 dB in normals and from 0.08 dB to 3.23 dB in the case of vocal polyps. Although, some overlap between the two groups was observed they noted that the measured value may be an useful index in screening for laryngeal disorder or for diagnosis of such disorder and differentiation between the two groups.

Vowel produced and sex are the two factors affecting shimmer values as reported in the literature. SORENSEN and HORII (1983) reported that normal female speakers have less shimmer than normal male speakers. WILCOX and HORII (1980) reported that shimmer values were different for different vowels. SORENSEN and HORII (1983) studied the vocal shimmer during sustained phonation of /a/, /i/ and /u/ vowels. The results showed that shimmer values were lowest for /u/ with 0.19 dB, highest for /a/ with 0.33 dB and intermediate for /i/ with 0.23 dB. These results were supported by HORII (1980).

HIGGINS and SAXMAN (1989) investigated within subject variation of 3 vocal frequency perturbation indices over

multiple session for 15 female and 5 male young adults (pitch perturbation quotient and directional perturbation factor). Co-efficient of variation for pitch perturbation quotient and directional perturbation factor were considered indicative of temporal stability of these measures, while jitter factor and pitch perturbation quotient provided redundant information about laryngeal behaviour. Also jitter factor and pitch perturbational quotient varied considerably within the individual across sessions, while directional perturbation factor was a more temporarily stable measure.

VENKATESH et al. (1992) reported Jitter Ratio (JR), Relative Average Perturbation, 3 point (RAP 3), Deviation from Linear Trend (DLT), Shimmer in dB (SHIM) and Amplitude Perturbation Quotient (APQ) to be most effective parameters in differentiating between normal males, normal females and dysphonic groups. They added that in the clinical application, Shimmer is most effective parameter and act like a quick screening device and in pitch perturbation measures like jitter ratio(JR), relative average perturbation (3 point) and DLT are most useful in differentiating laryngeal disorders.

SRIDHARA (1986) studied glottal waveforms of young normal males and females. The results are given below in the table (a) and (b).

Table (a)

	Mean Values of Jitter (in msec)		
	/a/	/i/	/u/
Males	0.065	0.11	0.067
Females	0.058	0.03	0.048

Table (b)

	Mean Values of Shimmer (in msec)		
	/a/	/i/	/u/
Males	0.033	0.066	0.15
Females	0.07	0.37	0.44

Based on the review of studies it can be inferred that pitch and amplitude perturbation measurements and extent and speed of fluctuation in frequency and intensity can effectively be used in detect in and differentiating laryngeal pathologies and also differentiating normal males, normal females and pathological groups.

#### ELECTROGLOTTOGRAPHY

The acoustic analysis of voice-HIRAND (1981) states that "this may be one of the most attractive method for



assessing phonatory function or laryngeal pathology because it is non-invasive and provides objective, and quantitative data.

Many acoustic parameters derived by various methods, have been reported to be useful in differentiating between the pathological voice and normal voice. But HANSON et al. (1983) reported that the acoustical measurements do not necessarily have a direct physiological correspondence to abnormal glottal activity.

The aerodynamic aspects of phonation is characterized by four parameters mainly subglottal pressure, supraglottal pressure, glottal impedance and volume velocity of the airflow at the glottis (HIRANO, 1981). These measurements also have been reported to be related to listeners rating of deviant voice dimensions (HANSON ET AL. 1983).

Measurements that can be related to the normal physiology and patho - physiology of normal behaviour are highly described. Since phonatory dysfunction, usually manifests as a result of abnormal oscillatory movements, the measurement and analysis of the vibratory pattern of vocal

folds has the potential to provide detailed information on the pathophysiology of the vocal folds during phonation (HANSON et al. 1983).

The study of vibratory movements has drawn a lot of interest of researchers recently. Several methods have been developed with the object of visualizing the rapid movements of vocal folds.

#### Methods of Studying Vocal Fold Vibrations

The vocal cords vibrate at around 100-300 Hz during normal conversation and even at higher levels during singing. Observation of such vibrations require special methods. The following are some of the methods used to study vocal fold vibration.

- (i) Stroboscopy
- (ii) Ultra - sound glottography
- (iii) Ultra -high speed photography
- (iv) Inverse - filter method
- (v) Photo - electric glottography (PGG)
- (vi) Electroglottography (EGG)

Stroboscopy - SCHONHA (1960) was the first one to make extensive and pioneering studies with the use of a modern

laryngo-stroboscopy. In this technique, the light source of the stroboscopy emits intermittent cycles when the flashes are emitted at the same frequency as that of the vocal fold vibration. A sharp and clear still image of the vocal fold is observed, when the flashes are emitted at frequencies slightly less than the frequency of vocal fold vibration, giving rise to a systematic phase delay of the consecutive light flashes, a slow motion effect is produced (HIRANO, 1981). Stroboscopy does not give any objective reading but is entirely dependent on the investigators subjective impression of slow motion.

Ultra-sonic Glottography - This was first described by HERSCH (1964) makes use of short ultra-sound pulses generated by electrically excited ultrasound transducer with a repetition frequency of about 10 MHz (HOMER et al. (1973). The transducer probe place on the thyroid lamina, and reflected ultra-sound pulse will be picked up by a transducer, visualized as a curve on a cathode ray oscilloscope.

Ultra High Speed Photography - The technique involves photographing the vibrating movements of vocal cords by a

special camera at a speed of about 4,300 frames per second (HALLEN et al. 1977).

The larynx can be viewed directly in a small mirror suitably positioned for back in the mouth. By illuminating the vocal cords with a high intensity light beam, FRAMSWORTH was able to make movies of vocal cord motion of 4000 frames/sec.

This method is invasive and hence requires a great deal of co-operation from the subject. It is not only expensive but also consumes a lot of space and time.

Anatomical anomalies of pharynx and larynx may cause problem to photographers. But the advantage with this method is that it facilitates frame-by-frame analysis of various parameters of the vibration of vocal cords.

Inverse Filter Method - It is an acoustic procedure in which the inverse of the lip radiation and the vocal tract spectra contributions are used to remove the acoustic effects of the supraglottal vocal tract leaving the glottal volume flow.

The more abnormal the voice the more direct to choose inverse fitter parameters. This method was first described by MILLER (1959), SONDHI (1975). But a signal having larger fitter value, the inverse will be the poorest choice of techniques.

Photo-electric Glottography (PGG) - This is a technique (SONESSON, 1959 and 1960) in which light, being transilluminated through the skin of the neck, is allowed to pass through the glottis and is picked up by light conductive rod introduced into the mouth. When the vocal folds vibrate, the glottis is alternately closed and opened and the intensity of the light alternately varies, corresponding to the actual glottal area. The light conducting rod is connected to a multiplier phonetube, and onto a cathode-ray oscilloscope. A curve is then obtained which corresponds to the vibration of vocal cords.

This method is better than stroboscopy because graphical display is possible and better than ultra-high speed photography because it is economical. This method does not allow conclusions concerning the vibratory movements of one single vocal fold according to HOMER et al. (1973).

Photos electric glottography unlike electroglottography gives more information during the open portion of the glottal cycle (HANSON et al. 1983).

Electro-Glottography (EGG) - this is a technique in which the transverse electrical impedance varies with opening and closing of the glottis, and results in variation of the electrical current in phase with the vibratory phases of the vocal folds, resulting in glottogram (Lx).

The EGG, however, appears, to be considerably affected by artifacts, including variation in the impedance between the electrodes and the skin, vertical displacement of the relation to electrodes, conditions of cervical structures other than glottis, and so on. It is difficult to determine the extent to which the contact area of the vocal fold contributes to the output signal of EGG.

Discussing about the various parameters of voice, MICHEL and WENDAHAL (1971) state that "glottal wave form cannot be easily defined as some of the other parameters". Basically however, an index of glottal wave form may be obtained by calculating,

- (i) the opening time of the vocal folds
- (ii) the closing time of the vocal folds
- (iii) the open time
- (iv) the close time, all during a single vibratory cycle.

Different workers, give different descriptions of the glottal waveforms. For example, HIRANO (1981) divides one vibratory cycle into two major phases, the open phase and the closed phase. Open phase is further divided into the opening and closing phase.

MOORE and THOMPSON (1965) state that the following two conditions are present for normal phonation -

- (i) All the three phases for vibratory cycle i.e. opening phase, closing phase and closed phase.
- (ii) The motion of the two cords tend to be relatively synchronics and equal in amplitude during voicing, regarding frequency of excitation, perturbation in vibration, etc.

It makes use of motion induced vibration in the electrical impedance between two electrodes placed on the skin of the neck. The electrodes are placed above the thyroid laminae. A weak, high frequency voltage of 0.5 - 10

MHz is applied into one electrode and the other electrode picks up the electrical current passing through the larynx. The transverse electrical impedance varies with the opening and closing of the glottis, and result in a variation of the electric current in phase with the vibratory phases of the vocal fold.

The technique was first reported by FABRE (1957).

LECLUSE and his co-workers (1975, 1977) recorded EGG simultaneously with stroboscopic images, and related the EGG recording to the glottal images.

FOURLIN (1975) made simultaneous recordings of EGGs and airflow velocity curves for different modes of phonation and described the method to interpret the electroglottograms. He also emphasized that fundamental period of vocal fold vibration could be determined quite accurately using EGG.

In contrast to PGG whose output signal reflects the size of the glottal area during the open phase, the output signal of EGG convey information about the contrast area of the vocal folds (KOSTER and SMITH, 1970). So, EGG could be



useful for investigating the glottal condition during the closed phase.

However, various quotient and index can be calculated using the measurements of duration of different phases of vibratory cycle in order to study the glottal waveforms.

TIMCKE, VON LEDEN and MOORE (1958) expressed the relative duration of the phases of vibratory cycle in terms of quotients. Since then various quotients and indices have been derived using the measurements of duration of different phases of the vibratory cycle in order to study the glottal wave form.

(i) Open Quotient (OQ) - OQ is defined as the ratio of the open phase to the total period of vibration. i.e.

$$OQ = \frac{\text{Open phase}}{\text{Total duration of the cycle}}$$

There is a relationship between OQ and the fundamental frequency of vocal fold vibrations. OQ has been found to increase with increase in fundamental frequency (TIMCKE, 1957).

TIMCKE (1957 and 1960) observed an increase in OQ with falling intensity and decrease in OQ with raising intensity. But LUSCHINGER (1956) stated that OQ was practically independent of sound intensity (i.e. OQ was 0.66 and 0.86 at two pitch levels of 327 and 325 Hz at 65 phones. And 0.66 and 0.62 for these pitch levels at 80 phones).

TIMCKE further states that OQ was larger with open phase being larger. The value of OQ was 1.0 when there was no complete glottal closure.

It has been demonstrated mathematically (FLANAGAN, 1958) and experimentally (VAN den BERG, ZANTEMA and DOORENBELL, 1957; TIMCKE, VON LEDEN and MOORE, 1950) that the vocal intensity increases along with efficiency of the glottal generator, as the OQ decreases, i.e., as the fraction of the glottal cycle during which the glottis is open, becomes smaller. A smaller OQ describes a condition in which strong, short glottal pulses excite the vocal tract to resonate high harmonics, the sharper the puff, the richer the glottal wave in the high frequency components or high harmonics characterize acoustically powerful efficient vocal tones.

TIMCKE et al. (1958) illustrated the relationship between OQ and the period of vibration between OQ and the period of vibration with respect to vocal intensity.

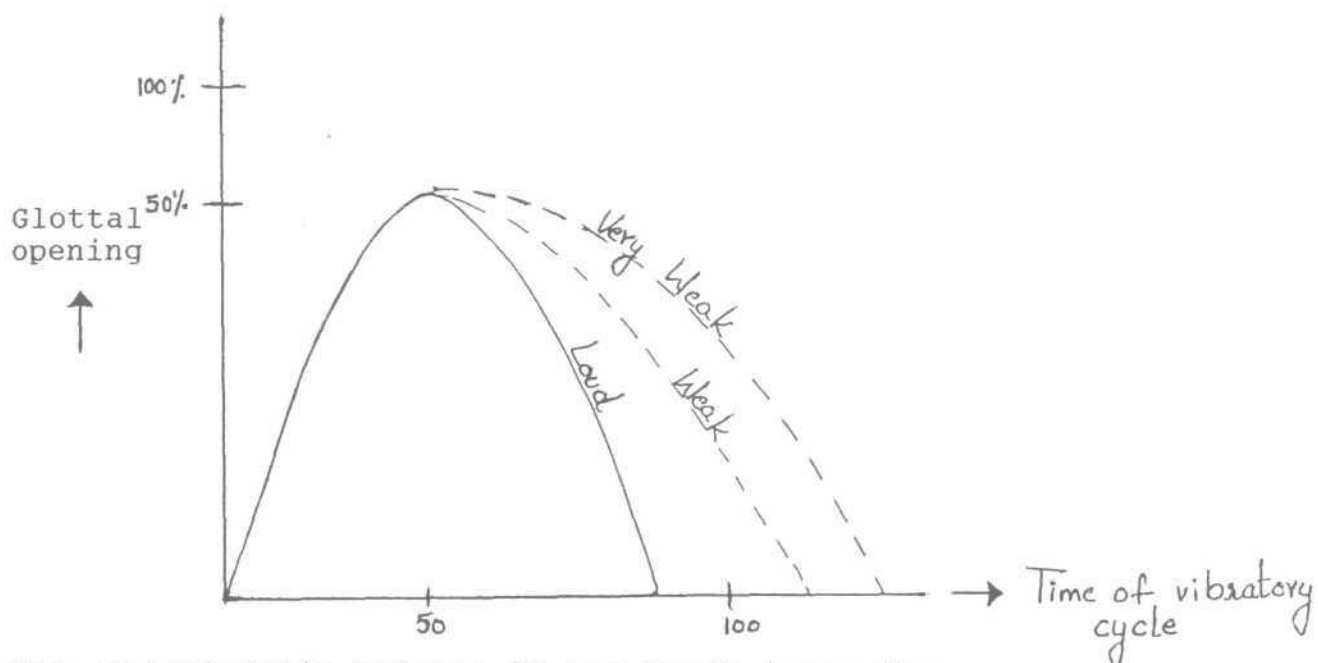

Fig. Relationship between OQ and vocal intensity.

In the above figure, the opening phase was stable with loudness change. Loudness was a function of closing phase only at low frequency. At high frequency, muscles of exhalation help in increasing the intensity.

(ii) Speed Quotient (SQ) or Velocity Quotient (VQ)

The time relationships between the opening and closing phase of each vibrator in speech quotient, according to

LUSCHINGER (1965). The SQ was proportional to vocal intensity, but was not influenced by the changes in pitch, register, vocal type, or sex. During phonation, the vocal folds close faster than when they open. As the loudness increased the lateral displacement of the vocal folds also increased, as they were blown more vigorously apart (TIMCKE et al. 1958). For trained voices, less lateral displacement and a longer period of closure than for untrained, was reported by FLETCHER (1954). The value of SQ given by TIMCKE et al. (1958) was 1.17.

(iii) "S" ratio (SR)

SR is the ratio of contact phase to open phase. In normals, it is around 0.657, where as it is 0.608 in dysphonics.

(iv) Jitter and Shimmer (J&S)

Jitter and Shimmer are physical correlates of rough or hoarse voice (according to MOORE and THOMPSON, 1965; MICHEL, 1966; COLEMAN and WENDAHAL, 1967). A method of quantifying of normal and abnormal voice is to measure the differences

between the period of each successive cycle. This is jitter, which is expressed either in milliseconds or in percentage. Jitter is the extent of rapid abrupt change in adjacent periods of the fundamental frequency wave (IWATA and VON LEDEN, 1970). HORIGUDU, HOJI, BAER and GOULD (1986) have speculated a relation between jitter analysis of EGG wave forms and the degree of hoarseness (SPEARMAN's rank correlation coefficient  $V_s=0.73$   $p<0.0005$ ).

DEJONCKERE, LEBACQ (1985) made an attempt to quantify the shape of electroglottography signal. The purpose of their work was to provide an answer to the following question.

Can a single EGG parameter be easily and systematically quantified in order to show a possible difference between subjects with a characteristic pathology such as vocal nodules and normals?

In order to answer the question, they measured the quotient "S" for each curve. The "S ratio" is the ratio between the upper half of the cycle i.e., closed half and the lower half of the cycle i.e. open half.

Fig.

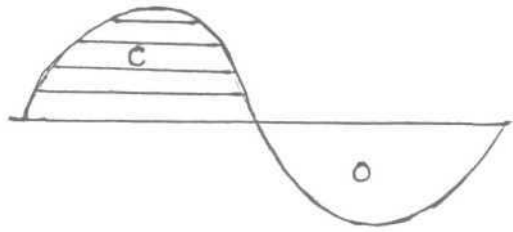

$$SR = \frac{\text{Closed half}}{\text{Open half}} = \frac{C}{O}$$

They concluded saying that, in case of pathological subjects the "S ratio" is much lower compared to normals (pathological subjects 0.4073 and normals 0.6569).

They also showed that mean value of "S ratio" significantly different and high among normals and vocal nodules cases. This is to say, that contact area is reduced in cases of vocal nodules conditions and this reduced vocal fold contact is an etiologic factor of vocal nodules.

KITZING and SONNENSON (1974) studied 20 young females during normal phonation using EGG and found that the values for open quotient (OQ) speed quotient (SQ) and rate quotient (RQ). For low pitch the values were 0.63, 1.1, 2.3 and for

high pitch it was 0.77, 1.1, 1.7 respectively. For weak intensity the values were 0.83, 1.1 and 1.5 and for strong intensity it was 0.70, 1.1, 2.1.

They concluded that -

- \* OQ increases as pitch increases and intensity decreases.
- \* SQ increases as intensity increases but ....influenced by pitch.
- \* RQ increases as intensity and pitch decreases.

DEJONKERE and LEBACQ (1985) - State that abnormal EGG has been considered in 5 different ways:

- (i) Pitch characteristic (too high or too low) KITZING (1979).
- (ii) Vibration irregularity (Jitter) demonstrated by histogram KITZING, 1979; FOURCIN, 1981.
- (iii) Spectral features of the signal in cases of diplophonia DEJONEKE and LEBACQ, 1983.
- (iv) Morphology of the waveform Van MICHEL, 1967.
- (v) Spectral analysis of the waveform KELMAN, 1981.

CHILDERS et al. (1990) conducted a study in order to correlate vocal fold physiology and electroglottography. They selected few parameters such as;

- (i) The instant of the opening of the glottis.
- (ii) The instant of the closing of the glottis.
- (iii) The instant of maximum opening of the glottis and compared between normal larynges and patents with disorders. They also made measurements using synchronized ultra high speed laryngeal films and EGG wave form collected from normals and pathological voices. Their research findings suggested that;
  - (a) Specific EGG features are associated with certain gross vibratory characteristics of both normal and pathologic voices (LEE and CHILDERS, 1989; PINTO, CHILDRENS and LALWANI, 1989). Although supporting data are still limited, even subtle vibratory characteristics appear to be reflected by the EGG wave form (HICKS, BAE, CHILDERS and MOORE, 1987).
  - (b) The EGG is confirmed as useful for analysis synthesis purposes, as well as for modeling laryngeal behaviour (CHILDERS et al. 1986).

Unfortunately the limitations include -

- (i) EGG - based voice performance impression (such as Fo, loudness, quality factors etc.) confirm what the clinician already can hear or can measure in the other way,



- (ii) The EGG reveals little about voice quality, for example, a breathy voice may have an EGG similar to that of a voice the complete glottal closure (CHILDERS and KRISH NAMURTHY, 1987).
- (iii) The EGG cannot recognize some significant features of vocal fold physiology. Photographic evidence reveals that the vocal fold can vibrate with many variation in the amount and region of contact, and with change in fold contours and do not involve contact. Because the EGG is designed to monitor vocal fold contact (not movement per se), it is unable to monitor these non-contact types of vibratory patterns.
- (iv) The wave form is not in a form that can be understood or communicated.

Variations in fundamental frequency (period) and amplitude of successive glottal pulses and referred as Jitter and Shimmer respectively. Because of their minute nature, their measurements were time consuming and difficult, and normative data on jitter and shimmer have been slow to accumulate. Excessive amounts of jitter and shimmer have been implicated as an indication of laryngeal dysfunction, however and also together with spectral noise

components, as acoustic correlates of rough or hoarse voice quality (HEIBERER and HORII, 1982).

In case of orally voice the laryngeal waveform typically shows pairs of vocal contact separation sequence in which a small peak precedes a long peak, both occurring with considerable temporal irregularities. The small peak has a relatively slower onset than the long and the width of large peak indicates a very long closure duration.

FOURCIN (1981), using Fx histograms, was able to differentiate between laryngitis and normals. He has described about the age and the possible effects of smoking using Fx histograms.

He has also studied pathological subjects like recurrent laryngeal nerve palsy, laryngeal carcinoma and vocal polyp. Discussing about the use of laryngographic studies he states that studying of Lx wave form is useful function but also helpful in therapy.

KELMAN (1981) adopted a methodology similar to the present study and he obtained the following results for vowel /u/ 12 cycle (154 Hz) produced by a male and vowel /i/

14 cycle (204 Hz) produced by a female. He did find consistent difference in the result obtained from different vowels. In this study the majority of phonation requires between 7-16 cycles, for the amplitude to become steady. His data showed that the male subjects took significantly longer time than the female subjects to attain steady amplitude. These probably reflect higher fundamental frequency for female and also greater mass and inertia of male vocal folds.

In recent years electroglottography (EGG) has often been used to identify various vibratory modes of the vocal folds thus giving a more precise notion of the vocal register. The two main laryngeal mechanisms (Mechanism I, Heavy or chest register and Mechanism II, high or falsetto register) has clearly identified EGG traces, ASKENFELT, 1981; KITZING, 1982, LECTUSE, 1977.

SRIDHARA (1986) studied laryngeal waveforms in 30 young normal females and males using /a/, /i/ and /u/ vowels. He has reported the following values for different parameters of laryngeal waveforms.

(i) Open Quotient

Sex	Mean Values of OQ		
	/a/	/i/	/u/
Male	0.69	0.71	0.72
Female	0.74	0.72	0.71

(ii) Speed Quotient

Sex	Mean Values of SQ		
	/a/	/i/	/u/
Male	1.98	1.74	1.79
Female	2.25	2.28	2.30

(iii) Speed Index

Sex	Mean Values of SI		
	/a/	/i/	/u/
Male	0.398	0.247	0.266
Female	0.377	0.361	0.362

(iv) "S Ratio"

Sex	Mean Values of SR		
	/a/	/i/	/u/
Male	1.13	1.12	1.11
Female	1.13	1.10	1.09

Amplitude perturbation or amplitude variation from cycle to cycle is shimmer, expressed in dB. HORIGUDU, HAJI, BAER and GOULD (1986) found that shimmer was more sensitive to laryngeal pathology than jitter. Both jitter and shimmer differentiate extremely and moderately hoarse voice, but only shimmer could differentiate between moderately and slightly hoarse voice.

Jitter and Shimmer have been found to be useful in differentiating normal from abnormal voice by KOIKE, 1969, 1973; MICHEL et al. 1973; HORII, 1978, 1979 and others. In fact LIBERMAN (1963). MONTGOMERY et al. (1970) have reported early detection of laryngeal pathology using shimmer and/or jitter.

A comfortable level, average jitter is 1% or less in phonation. Different values of jitter and shimmer as reported by different investigators.

Jitter 0.6% (Jakob, 1968) and  
0.5% (Horii, 1982)

Shimmer 0.1 dB (Koike, 1969; Gould and Kitajoma, 1976), and  
0.5 dB (Horii, 1982)

Jitter and Shimmer differences have been shown to exist among different vowels by HORII (1982). Normative data from WILCOX and HORII (1960) have shown that /u/ was associated with significantly smaller jitter (0.55%) than /a/ and /i/ for which the value is 0.68% and 0.69% respectively.

JOHNSON and MICHEL (1969) have reported a higher jitter for high vowels than for low vowels. It has also been reported that when subjects were asked to phonate at a

special intensity and/or as long as possible, jitter and shimmer values increased.

HORII (1982) observed that vocal fry was characterized by greater jitter and shimmer values than in modal phonation i.e. 2.5 Vs. 0.9% of jitter, 1.15 Vs. 0.48 dB of shimmer respectively.

MOUSEN, ENGBRETSON and VEMULA (1979) have found the rate of jitter to be higher for hearing-impaired. For normals, jitter rate tended to be closer to the maximum period-to-period change, while for hearing-impaired maximum period-to-period change was greater than average jitter.

MONSEN et al. (1979) found that in most of the hearing-impaired, the average shimmer was between 0.02 to 0.06 dB (which is also the normal range) but a few had double this amount. The larger amounts of jitter and shimmer constituted an incipient form of diplophonia, or at least were related to diplophonia in cause.

There are divergent results pointing to the complexity of the relationship among a larger number of variables that

affect vocal production. Studies are needed to determine the variables and their interaction in voice production (PERKINS, 1982).

The nature of sound generated by vibration of vocal folds can be specified in terms of acoustic and psychoacoustic terms. These (fundamental frequency, spectrum, time related variables) are useful in drawing a voice profile as they provide objective and quantitative data.

Norms of acoustic parameters have been given, for Indian population, by KUSHALRAJ (1984), RASHMI (1985), VANAJA (1986) and SRIDHARA (1986). Sridhara has given normative data for the parameters measured on EGG. A study of the acoustic parameters in the hearing-impaired was done by RAJANIKANTH (1986). Such information is useful in providing therapy goal and to check the effectiveness of a technique.

The normative values given by SRIDHARA (1986) using EGG for the vowels /a/, /i/ and /u/ are :

OQ was found to be 0.52 in males and females.

SQ was 1.84 in males and 2.17 in females being (significant at 0.001 level).

SI was 0.29 in males and 0.03 in females (the difference between males and females being (significant at 0.05 level)).

S ratio was 1.12 in both females and males, jitter value was 0.06 msec. in males and 0.046 msec. in females (difference significant at 0.05 level).

The Review of Literature so far indicates that most of the studies are on subjective evaluation (i.e. listener as an analyzer) (HUDGINS and NUMBERS, 1942; PENN, 1958; COLVER, 1962; MORTONY, 1965; NOBER, 1967; MARKIDES, 1970; SMITH, 1975; McGARR, 1978; GEFNER, 1980).

Thus, the review of literature indicates that the study of vocal cord vibration using EGG provides a very useful information in understanding the physiology of both normal and abnormal voice productions. Such an information will be of great help in the diagnosis and treatment of voice disorders.

Further, as GILBERT (1984) states that this is a non-invasive method, it neither disrupts phonation nor requires uncomfortable illuminating and photographic equipment to be positioned in the vocal tract. Moreover, laryngography



leaves the subject unencumbered for continuous speech and other monitoring procedures.

From the review, it is clear that there is no much literature available on multidimensional measurements of voice of the hearing-impaired. Thus, the purpose of this study was to use a multidimensional voice analysis for the hearing-impaired. The different parameters taken were as follows:

I.[A] Fundamental Frequency Measures:

- (1) Mean fundamental frequency
- (2) Maximum fundamental frequency
- (3) Minimum fundamental frequency
- (4) Range of fundamental frequency
- (5) The number of fluctuation in frequency/sec.
- (6) Extent of fluctuation in frequency.

[B] Intensity measures

- (1) Mean intensity
- (2) Maximum intensity
- (3) Minimum intensity
- (4) Range of intensity
- (5) The number of fluctuation in intensity/sec.
- (6) Extent of fluctuation in intensity.

## METHODOLOGY

The present study is aimed at examining the various parameters of voice of hearing impaired children using multidimensional analysis of voice. The multidimensional analysis consisted of the fundamental frequency and intensity and related parameters, electroglottographic measures and pitch and amplitude perturbation measures. It was decided to use phonation(/a/, /i/ and /u/) for the purpose of analysis.

### SUBJECTS:

Twelve hearing-impaired children (6 males and 6 females) in the age range of 5-9 years were selected for the study. Their hearing pure tone threshold levels (HTL) ranged from 70-90 dB. The subjects had normal intelligence, and normal speech mechanism. These children were selected from AIISH Therapy Clinic, who were under going speech and language therapy. No attempt was made to include only the good speakers or to exclude the particularly poor speakers. (Details of these subjects are given in Appendix-A).

Twelve subjects having normal hearing and with no known history of speech & or hearing problem served as control group. These two groups were matched for age, sex and intelligence except on hearing sensitivity. This group also had normal speech mechanism.

## SPEECH SAMPLES FOR ANALYSIS:

Phonation of vowels /a/, /i/ and /u/, three times each, for five seconds by each subject were used as voice samples for the study.

## INSTRUMENTATION:

The following instruments were used for the study:

- (1) Mic- Ahuja ADC - 535 m
- (2) Electrolaryngograph (Kay Elemetrics Corporation)
- (3) PC-AT computer based on Intel 80386 microprocessor and Intel 80387 NDP.
- (4) VSS - 12 bit ADC and DAC data output and input cord with SIU (Speech Interface Unit).
- (5) VSS- software programme for pitch and intensity analysis.

The instruments were arranged as shown in the block diagram:

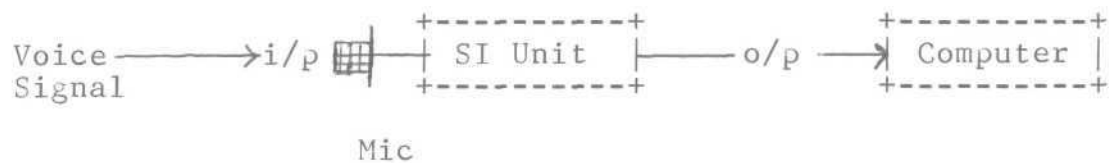

Figure 1: Block diagram showing arrangement of instruments for the purpose of recording and analysis of voice of the subjects .

All the instruments were calibrated prior to the experiments as per the instructions given in the manual of instruments.

#### EXPERIMENT I:

The purpose of this part of the study was to analyze the voice to obtain fundamental frequency and intensity and related parameter in normal and hearing impaired individuals using the computer programme "Inton analysis" to obtain the following parameters-

##### (A) Fundamental Frequency Measures:

- 1) Mean fundamental frequency
- 2) Maximum fundamental frequency
- 3) Minimum fundamental frequency
- 4) Range of fundamental frequency
- 5) Speed of fluctuation in frequency
- 6) Extent of fluctuations in frequency

##### (B) Intensity Measures:

- 1) Mean intensity
- 2) Maximum intensity
- 3) Minimum intensity
- 4) Range of intensity
- 5) Speed of fluctuations in intensity
- 6) Extent of fluctuations in intensity

## PROCEDURE:

The subject was seated comfortably. Then the subject was given the following instructions:-

"Now we are going to record your voice. Please start saying /a/ using your usual or natural pitch and loudness and continue it till I say stop. We will do this three times." The instructions were given in Kannada (as all the subjects tested knew Kannada), supplemented by tactile cues and demonstration for the hearing-impaired subjects. Subjects were also wearing hearing aids.

The microphone was kept 6 inches away from the mouth of the subject. The output of the microphone was fed to the Speech Interface unit, which was interfaced with the computer which had AD/DA card and programmes to record and store the acoustic signal on the hard disk. As each subject phonated, the voice signal was recorded on the computer at a sampling rate of 16 KHz. The level indicators on the Speech Interface unit was used to monitor the intensity level to avoid any distortion in recording. The phonation signal of approximately five secs was recorded and stored in the hard disk of the computer, which was used for analysis at a later stage. Each subject of both the groups, produced vowel /a/ three times each and all the samples were

recorded and stored. Similarly three productions of vowel /i/ and three productions of vowel /u/ by each subject of both the groups were recorded and stored on the computer hard disk.

The analysis was done using the programme "Inton analysis" (VSS, Bangalore) The analysis yielded the following parameters -

(A) Fundamental Frequency Measures:

- 1) Mean fundamental frequency
- 2) Maximum fundamental frequency
- 3) Minimum fundamental frequency
- 4) Range of fundamental frequency
- 5) Speed of fluctuation in frequency
- 6) Extent of fluctuations in frequency

(B) Intensity Measures:

- 1) Mean intensity
- 2) Maximum intensity
- 3) Minimum intensity
- 4) Range of intensity
- 5) Speed of fluctuations in intensity
- 6) Extent of fluctuations in intensity

## EXPERIMENT II:

The purpose of this part of the stud/ was to analyze the vocal fold movement during phonation in hearing-impaired and normal individuals using electroglottography. The parameters selected for the purpose were:

- (1) Open Quotient (OQ)
- (2) Speed Quotient (SQ)
- (3) Speed Index (SI)
- (4) "S" ratio

## PROCEDURE:

The subjects were seated comfortably in front of the instruments. The two electrodes were placed on the two thyroid alae. The position of the electrodes were adjusted until clear laryngeal waveform appeared on the screen, when the subject phonated. Artifacts such as, variations in the impedance between the electrodes and the skin, vertical displacement of larynx in relation to electrodes etc., were avoided.

Each subject, was given the following instructions. "Now I am going to put this band around your neck like this (demonstration) then, please say, /a/ in your usual or natural pitch and loudness as soon as I say 'start' and continue it till I say stop".

## **CERTIFICATE**

This is to certify that the dissertation entitled  
MULTI-DIMENSIONAL ANALYSIS OF VOICE OF THE HEARING-IMPAIRED  
has been prepared under my supervision and guidance.

Mysore  
May 1996

Dr. N.P. Nataraja  
Professor and H O D  
Dept. of Speech Science  
All India Institute of  
Speech and Hearing  
Mysore 570 0006



II. Electroglographic measures.

- (1) Open Quotient
- (2) Speed Quotient
- (3) Speed Index

III. Pitch and amplitude perturbation measures:

- (1) Jitter ratio (JR)
- (2) Directional perturbation factor for frequency (DPF-Frequency)
- (3) Relative average perturbation (RAP-3 point)
- (4) Shimmer [S(dB)]
- (5) Directional perturbation factor for amplitude (DPF-amplitude)
- (6) Amplitude perturbation quotient (APQ).

The above hypothesis were tested as follows.,

Twelve hearing-impaired and twelve normal hearing subjects, (six males and six females) with a age range of five to nine years respectively, served as subjects. Three productions of /a/, /i/ and /u/ were recorded and analysed using computer, to obtain the above mentioned parameters. The results have been presented and discussed.

#### IMPLICAT IONS OF THE STUDY:

- 1) The study is hoped to provide information about the effect of hearing impairment on the normal production.
- 2) It is hoped that information gained from the multidimensional analysis would help in adding to the existing therapeutic techniques.
- 3) It provides information regardiung the phonatory mechanism in hearing impaired individuals.

#### LIMITATIONS OF THE STUDY:

- 1) The study was limited to the age group of 5-9 years and the number of subject used is less.
- 2) The study is only limited to only certain aspects of voice.
- 3) All degrees and types of hearing loss subjects were not studied.

## **CERTIFICATE**

This is to certify that the dissertation entitled

**MULTI-DIMENSIONAL ANALYSIS OF VOICE OF THE HEARING-IMPAIRED**

has been prepared under my supervision and guidance.

Mysore  
May 1996

**Dr. N.P. Nataraja**  
Professor and HOD  
Dept. of Speech Science  
AH India Institute of  
Speech and Hearing  
Mysore 570 0006

## CERTIFICATE

This is to certify that the dissertation entitled  
**MULTI-DIMENSIONAL ANALYSIS OF VOICE OF THE HEARING-IMPAIRED**  
has been prepared under my supervision and guidance.

Mysore  
May 1996

**Dr. N.P. Nataraja**  
Professor and HOD  
Dept. of Speech Science  
All India Institute of  
Speech and Hearing  
Mysore 570 0006

## **CERTIFICATE**

This is to certify that the Dissertation entitled  
MULTIDIMENSIONAL ANALYSIS OF VOICE OF THE HEARING-IMPAIRED  
is the bonafide work in partial fulfilment for  
final year M.Sc, (Speech and Hearing) of the student with Reg.No. M9402.

Mysore  
May 1996

All

Dr.(Miss) S. Nikam  
Director  
India Institute of  
Speech and Hearing'  
Mysore 570 006

## **CERTIFICATE**

This is to certify that the dissertation entitled  
**MULTI-DIMENSIONAL ANALYSIS OF VOICE OF THE HEARING-IMPAIRED**  
has been prepared under my supervision and guidance.

Mysore  
May 1996

**Dr. N.P. Nataraja**  
Professor and HOD  
Dept. of Speech Science  
All India Institute of  
Speech and Hearing  
Mysore 570 0006

## **CERTIFICATE**

This is to certify that the Dissertation entitled  
MULTIDIMENSIONAL ANALYSIS OF VOICE OF THE HEARING-IMPAIRED  
is the bonafide work in partial fulfilment for  
final year M.Sc, (Speech and Hearing) of the student with Reg.No. M9402.

Mysore  
May 1996

Dr.(Miss) S. Nikam  
Director  
All India Institute of  
Speech and Hearing  
Mysore 570 006

## **CERTIFICATE**

This is to certify that the Dissertation entitled  
MULTIDIMENSIONAL ANALYSIS OF VOICE OF THE HEARING-IMPAIRED  
is the bonafide work in partial fulfilment for  
final year M.Sc, (Speech and Hearing) of the student with Reg.No. M9402.

Mysore  
May 1996

Dr.(Miss) S. Nikam  
Director  
All India Institute of  
Speech and Hearing'  
Mysore 570 006



## **CERTIFICATE**

This is to certify that the Dissertation entitled  
MULTIDIMENSIONAL ANALYSIS OF VOICE OF THE HEARING-IMPAIRED  
is the bonafide work in partial fulfilment for  
final year M.Sc, (Speech and Hearing) of the student with Reg.No. M9402.

Mysore  
May 1996

Dr.(Miss) S. Nikam  
Director  
All India Institute of  
Speech and Hearing'  
Mysore 570 006

## **DECLARATION**

This dissertation is the result of result of my own study undertaken under the guidance of Dr. N.P. Nataraja, Professor and HOD. Speech Sciences, All India Institute of Speech and Hearing, Mysore, and has not been submitted earlier at any University for any other Diploma or Degree.

Mysore  
May 1996

Reg-

No.M9402

## DECLARATION

This dissertation is the result of result of my own study undertaken under the guidance of Dr. N.P. Nataraja, Professor and HOD. Speech Sciences, All India Institute of Speech and Hearing, Mysore, and has not been submitted earlier at any University for any other Diploma or Degree.

Mysore  
May 1996

Reg.

No.M9402

## **DECLARATION**

This dissertation is the result of result of my own study undertaken under the guidance of Dr. N.P. Nataraja, Professor and HOD. Speech Sciences, All India Institute of Speech and Hearing, Mysore, and has not been submitted earlier at any University for any other Diploma or Degree.

Mysore  
May 1996

Reg- No.M9402

## **DECLARATION**

This dissertation is the result of result of my own study undertaken under the guidance of Dr. N.P. Nataraja, Professor and HOD. Speech Sciences, All India Institute of Speech and Hearing, Mysore, and has not been submitted earlier at any University for any other Diploma or Degree.

Mysore  
May 1996

Reg- No.M9402



### Electrodes

Figure 2: The Block diagram of instruments used for obtaining electroglottogram and its analysis.

The signal from the laryngograph was fed to the computer through the Speech Interface unit. As each subject phonated the voice signal was recorded on the computer at a sampling rate of 16 KHz. The level indicators on the Speech Interface unit was used to monitor the intensity level to avoid any distortion in recording. The phonation signal of approximately five secs was recorded and stored on the harddisk of the computer, which was used for analysis at a later stage. Each subject of both the groups, produced vowel /a/ three times each and the same was recorded and stored. Similarly three productions of vowel /i/ and three productions of vowel /u/ were produced by each subject of both the groups and were recorded and stored on the computer hard disk. The display of the glottal waveform was obtained and was used to measure different parameters. The display (on the computer monitor) of the glottal waveform in terms of time (in milli seconds) on the X-axis and amplitude of the signal (in millivolts) on y-axis. The time at any given point could be measured by moving the cursor horizontally.

Time at Cursor : 224.59 msec

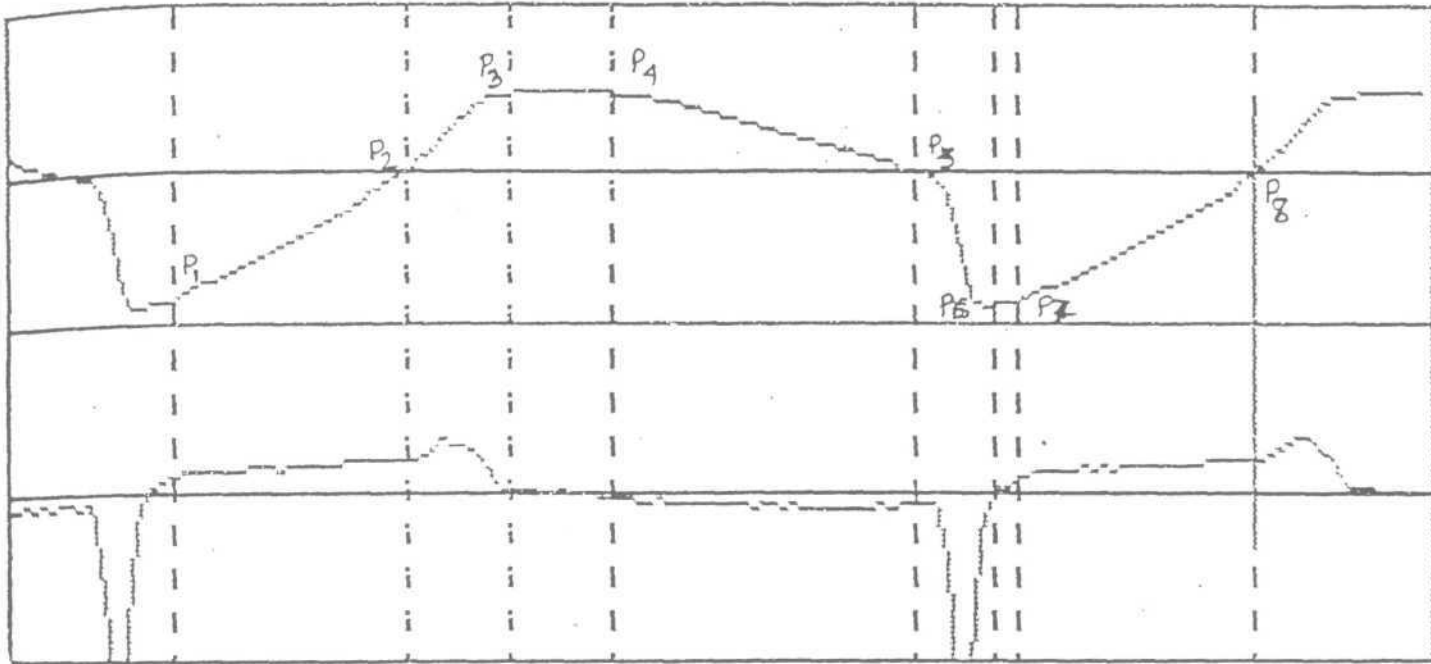

208.00 msec

227.00 msec

Accept the points marked (Y/N)   
mark Point 8

FIG.2: SHOWING DIFFERENT PHASES OF VIBRATORY CYCLE IN msec.

P<sub>3</sub> - P<sub>1</sub> = opening period

P<sub>6</sub> - P<sub>3</sub> = Open period

P<sub>6</sub> - P<sub>4</sub> = closing period

P<sub>7</sub> - P<sub>6</sub> = closed period

P<sub>2</sub> - P<sub>8</sub> = period of the vibratory cycle

P<sub>5</sub> - P<sub>2</sub> = Base of the open phase

P<sub>8</sub> - P<sub>5</sub> = Base of the contact phase

From the display of the waveforms of the recorded signal ten successive cycles of glottal waveform were selected for further analysis. Each cycle was analysed at different points by moving the cursor, to obtain the duration of different phases of vocal fold vibration. After marking different points in each cycle, different parameters of the laryngeal wave form were calculated by the computer and the results were displayed. Thus for each subject

- (1) Open Quotient (OQ)
- (2) Speed Quotient (SQ)
- (3) Speed Index (SI)
- (4) "S" ratio

were obtained for all the productions of /a/, /i/, and /u/.

#### EXPERIMENT III:

The purpose of this part of the study was to analyse the pitch and amplitude perturbation during phonation in normal and hearing-impaired individuals. The voice samples of /a/, /i/, and /u/ of all subjects recorded for Experiment II i.e., using Electrolottograph was used for this experiment also. By analysing the voice signal using 'Jitshim' programme (VSS, Bangalore) the following parameters were obtained.



(A) Pitch Perturbation Measures

(1) Jitter ration (JR)

(2) Directional Perturbation factor for frequency (DPF - fq.)

(3) Relative Average Perturbation (Three point) (RAP-3 point).

(B) Amplitude Perturbation Measures

(1) Shimmer (dB) [S.(dB)]

(2) Directional Perturbation factor for Amplitude (DPF-Amp)

(3) Amplitude Perturbation Quotient (APQ)

STATISTICAL ANALYSIS:

The data was further subjected to statistical analysis using "Epistat" Programme to obtain descriptive and inferential information. Mann - whitney 'U' test was used to compare the groups for significance of difference.

## RESULTS AND DISCUSSIONS

The present study aims at multidimensional evaluation of the voice of the Hearing Impaired children. This study was carried out as follows.

(A) Determining the difference between normal and hearing-impaired children in terms of the parameters of fundamental frequency and intensity of voice of vowels /a/, /i/ and /u/. The fundamental frequency parameters studied were;

- (i) Mean fundamental frequency (FO)
- (ii) Maximum fundamental frequency in phonation (Max FO)
- (iii) Minimum fundamental frequency in phonation (Min FO)
- (iv) Range of fundamental frequency (Range FO)
- (v) Speed of fluctuations in fundamental frequency (Flu/sec)
- (vi) Extent of fluctuation in fundamental frequency (Ext/flu)

The intensity parameters studied were

- (i) Mean intensity (Mean AO)
- (ii) Maximum intensity (Max AO)
- (iii) Minimum intensity (Min AO)
- (iv) Range of intensity (Range AO)
- (v) Speed of fluctuations in intensity (Flu/sec)
- (vi) Extent of fluctuations in intensity (Ext/flu AO).

Determining the difference between normals and hearing impaired children in terms of parameters of EGG measures for

vowels /a/, /i/ and /u/. The EGG parameters studied were as follows;

- (i) Open Quotient (OQ)
- (ii) Speed Quotient (SQ)
- (iii) Speed Index (SI)
- (iv) "S" Ratio

C. Determining the difference between normal and hearing impaired children in terms of frequency and amplitude and perturbation measures. The frequency perturbation measures studied were;

- (i) Jitter Ratio (JR)
- (ii) Directional Perturbation Factor for frequency (DPF-Freq)
- (iii) Relative Average Perturbation (RAP)

These parameters were studied for both males and females. The mean, and standard deviation of all the parameters for both males and females of both the groups were calculated. The significance of differences between the males and females were also determined, using the 'EPISTATE' software.

The results and discussion of each of the parameters are given here.

Fundamental frequency measures:

- (1) Mean Fundamental Frequency (FO)

The means and the standard deviation of Fundamental frequency of vowels /a/, /i/, and /u/ for both hearing

impaired and normal males and females and provided in Table-1 and 2 along with significance difference between males and females for each group.

The normal male indicated a mean Fundamental frequency of 266.79 Hz, 272.42 Hz and 288.22 Hz for the vowels /a/, /i/ and /u/ respectively. The hearing impaired males showed a mean Fundamental frequency of 291.73 Hz, 300.06 Hz and 286.22 Hz for /a/, /i/ and /u/ respectively. Thus the hearing impaired males showed a higher mean values which is evident from the study of Graphs 1, 2 and 3.

However, there was no significant difference between hearing impaired males and normal males statistically.

The normal female group indicated a mean of 289.03 Hz, 287.45 Hz and 298.50 Hz for the vowels /a/, /i/, and /u/ respectively. The Hearing Impaired females showed high mean values i.e., 349, 354.99 Hz and 343.11 Hz for /a/, /i/ and /u/. Thus the Hearing Impaired females also showed a higher value for the vowels /a/, /i/ and /u/ than the normal females.

The normals showed a range of 266.79 Hz to 290.32 Hz where as the Hearing Impaired showed a greater range of fundamental frequency i.e., 291.23 Hz to 360 Hz.

The Table-2 shows the t-values. According to which no differences between normal males and normal females and normal males and Hearing Impaired males were found. But,

significant difference was seen between normal females Vs Hearing Impaired females and Hearing Impaired males Vs Hearing Impaired females in terms of fundamental frequency of voice. Thus, there was significant difference between Hearing Impaired and normals in Fundamental frequency. Therefore the auxiliary hypothesis (1) Stating that, there is no significant differences between Hearing Impaired and Normal males and femals in mean fundamental frequency, is rejected.

These results agree with that of reports by several investigators (AUGELOCCI, KOOP & HOLBROOK, 1964, BOONE, 1966; ENGELBERG 1962; MORTONY 1968) who have noted that deaf speakers do have a relatively higher average pitch or to speak in falsetto voice.

The difference in Fundamental frequency between vowels in some deaf speakers, as found in this study, also been reported by Angelocci, Kopp and Holbrook(1964). They attribute this type of abnormal pitch to efforts by deaf speakers to differentiate vowels by varying FO and amplitude rather than frequency and amplitude of formants. "In physiological terms, he is achieving vowel differentiation by excessive laryngeal variation with only minimal articulatory variation".

Thus the study of fundamental frequency in males and females in the normal and Hearing Impaired group have showed the following results-(i) In males there was no significant difference between the groups.

(ii) The females showed significant difference between the two groups.

(iii) The significant difference was observed between Hearing Impaired males and females in fundamental frequency

(iv) The fundamental frequency for vowel /a/ was lowest in comparison with /i/ & /u/ which were variable in different age groups for both males and females.

Tabel - 1: Shows the mean and standard deviation (SD) of mean fundamental frequency of phonation in Hearing Impaired and normal males and females for the vowels /a/, /i/ and /u/.

Vowels	/a/		/i/		/u/	
	Mean	SD	Mean	SD	Mean	SD
N - M	266.79	17.73	277.42	18.14	288.22	14.98
HI - M	291.73	53.77	300.06	63.53	286.22	61.05
N - F	289.03	30.97	287.45	28.29	288.50	36.64
HI - F	349.00	29.82	354.99	37.56	343.11	36.50

Table - 2: Shows the t-value and significant difference (Sig D) for fundamental frequency of phonation in Hearing Impaired normal males and females for the vowels /a/, /i/ and /u/.

	N-M Vs N-F	N-M Vs HI-M	N-F Vs HI-F	HI-M Vs HI-F
/a/ t-value	2.45	1.02	4.07	3.73
Sig-D	-	-	+	+
/i/ t-value	1.22	.75	2.67	1.87
Sig-D	-	-	-	-
/u/ t-value	.54	7.51	1.52	2.5
Sig-D	-	-	+	-

## 2) Maximum fundamental frequency (Max FO):

Table-3 and 4 provide the mean and standard deviation of maximum fundamental frequency for vowels /a/, /i/, and /u/ for both males and females and the significance of the difference between the two groups.

The normal males showed a mean of 287.60 Hz, 270.98 Hz and 303.5 Hz for the vowels /a/, /i/ and /u/ respectively. The Hearing Impaired males showed a mean of 310.19 Hz, 350.36 Hz and 334.63 Hz. Thus the Hearing Impaired males showed a higher mean value, which is also shown in groups 1, 2 and 3. However there was no significant difference between normal males and Hearing impaired males, statistically in terms of maximum fundamental frequency in phonation.

The normal females showed a mean of 303.58Hz 305.5 Hz and 303Hz for the vowels /a/, /i/ and /u/ respectively. The Hearing Impaired females also showed higher mean values of Maximum Fundamental frequency, i.e., 294.23 Hz, 428.74 Hz, 384.73 Hz. Thus the Hearing Impaired females also showed higher values for the vowels /a/, /i/ and /u/, which were statistically significant. Normals showed a range of 287.60 Hz to 305.43 Hz but the Hearing Impaired showed a higher range i.e., 294.23 Hz to 390.34 Hz. Thus auxiliary hypothesis to i.e. there is no significant difference between normal and Hearing Impaired males and females for maximum fundamental frequency has been rejected.

Table-4 shows that there was no significant difference for normal males Vs Normal females and Normal males Vs Hearing Impaired males. But significant difference was seen between Normal females Vs Hearing Impaired females and Hearing Impaired males Vs Hearing Impaired females. Thus, there is significant difference between Hearing Impaired and normals in maximum fundamental frequency only between the female groups. Thus auxiliary hypothesis to i.e. there is no significant difference between normal and Hearing Impaired males and females for maximum fundamental frequency has been rejected.

There was a significant difference between the two groups of females at 0.5 level for /a/, /i/ and /u/. Thus the hypothesis stating that there is no significant difference



between females of the two groups is rejected. Thus, maximum fundamental frequency in females showed a significant difference between the two groups.

Unlike the normal population the Hearing Impaired subjects showed higher maximum fundamental frequency. This may be due to improper control of the phonatory systems.

Based on the results of Maximum fundamental frequency in males and females of both the groups the following conclusions were drawn —

- (i) There was a significant difference between the two groups of females and not between the males of the two groups
- (ii) Significant difference was observed between Hearing Impaired males and Hearing Impaired females for the vowel /a/
- (iii) Among the 3 vowels, the mean of the maximum fundamental frequency of /i/ was the highest followed by /u/ sound /a/. The results of this study is similar to results of study by Rashmi (1985) who reported that maximum fundamental frequency was greatest for /i/ followed by /u/ and /a/ in normal subjects. This may be due to the fact that the vowel /a/ was produced at a frequency to the natural or optimum frequency of the subject than vowels /i/ and /u/ which were produced at a more higher frequency. Thus the results indicate that the Hearing Impaired individuals were not using

the respiratory and/or phonatory mechanisms efficiently.

**Table 3:** Shows the mean and standard deviation (SD) of maximum fundamental frequency of phonation in Hearing Impaired and normal males and females for the vowels /a/, /i/ and /u/.

Vowels	/a/		/i/		/u/	
	Mean	SD	Mean	SD	Mean	SD
N - M	287.60	23.21	270.98	20.66	303.53	46.74
HI - M	310.19	56.85	350.36	94.36	334.63	86.52
N - F	303.58	31.05	305.51	33.44	303	47.36
HI - F	294.23	46.18	428.74	48.54	384.73	42.38

**Table-4:** Shows the t-value and significant difference (Sig D) for maximum fundamental frequency of phonation Hearing Impaired and normal male and females for the vowels /a/, /i/ and /u/.

	N-M Vs N-F	N-M Vs HI-M	N-F Vs HI-F	HI-M Vs HI-F
/a/ t-value	1.23	1.29	3.97	5.02
Sig-D	-	-	+	+
/i/ t-value	2.62	1.89	2.94	1.71
Sig-D	-	-	+	-
/u/ t-value	1.85	1.19	58.99	2.50
Sig-D	-	-	-	-

3) Minimum Fundamental Frequency (Min FO): The minimum FO in phonation is defined as the minimum frequency in the steady portion of phonation.

Tables - 5 provides the mean and standard deviation of minimum fundamental frequency for vowels /a/, /i/ and /u/ for both males and females of normal and Hearing Impaired groups respectively.

Table 5: Shows the mean and standard deviation (SD) for minimum fundamental frequency of phonation in Hearing Impaired and normal males and females for the vowels /a/, /i/ and /u/.

Vowels	/a/		/i/		/u/	
	Mean	SD	Mean	SD	Mean	SD
N - M	249.63	28.42	252.99	13.45	184.96	93.86
HI - M	250.51	21.78	253.57	73.45	198.53	73.42
N - F	264.36	31.30	251.79	36.35	245.44	27.16
HI - F	255.79	83.20	245.99	100.23	289.52	64.28

**Table 6:** Shows the t-value and significant difference for minimum fundamental frequency of phonation in Hearing Impaired and normal males and females for the vowels /a/, /i/ and /u/.

	N-M Vs N-F	N-M Vs HI-M	N-F Vs HI-F	HI-M Vs HI-F
/a/ t-value	0.89	0.90	0.79	0.64
Sig-D	-	-	-	
/i/ t-value	4.85	0.23	0.93	0.40
Sig-D	-	-	-	-
/u/ t-value	0.89	0.60	1.03	2.62
Sig-D	-	-	-	+

Normal males showed a mean minimum fundamental frequency of 249.63 Hz; 252.99 Hz and 184.96 Hz for the vowels /a/, /i/ and /u/ respectively. The Hearing Impaired males showed a mean of 250.51 Hz and 253.57 Hz and 198.53 Hz. Thus the Hearing Impaired showed, as depicted in graphs 1, 2 and 3 showed, lower minimum fundamental frequency. However, statistically there was no significant difference between normal males and Hearing Impaired males for all the three vowels in terms of minimum fundamental frequency.

The normal females showed a mean of 264.36 Hz; 251.79 Hz and 245.44 Hz for the vowels /a/, /i/ and /u/ respectively. The Hearing Impaired females showed means of 255.79 Hz; 245.99 Hz and 289.52 Hz. Thus the Hearing Impaired females

showed mean values which were similar to normals. Further, this observation was substantiated by the statistical analysis, i.e., there was no significant difference between the two groups of females for /a/, /i/. Only a significant difference was seen for /u/ at 0.05 level in terms of mean minimum fundamental frequency in phonation in females.

The study of Table 5 shows higher mean values for Hearing Impaired female group. Further, the statistical analysis showed that there was significant difference between the normal females and Hearing Impaired females.

Thus the auxiliary hypothesis stating that there is a significant difference between normal and Hearing Impaired males and females for minimum fundamental frequency was rejected.

Further a comparison of normal males and females showed statistically there was no significant difference whereas the males and females of the hearing impaired group showed significant difference for vowel /u/ only. Thus the hypothesis stating that there is no significant difference in terms of minimum fundamental frequency between males and females of both groups is accepted.

#### 4) Range of fundamental frequency in phonation (Range F<sub>0</sub>):

The fundamental frequency range of the phonation is defined as the difference between maximum and minimum fundamental frequency in phonation.

**Table 7:** Shows the mean and standard deviation (SD) for range of fundamental frequency of phonation in Hearing Impaired and normal males and females for the vowels /a/, /i/ and /u/.

Vowels	/a/		/i/		/u/	
	Mean	SD	Mean	SD	Mean	SD
N - M	37.98	37.37	34.34	16.68	71.46	54.68
HI - M	163.44	31.39	123.71	146.24	96.19	144.52
N - F	39.21	35.24	53.77	50.55	31.14	22.23
HI - F	54.26	96.49	115.65	101.62	156.72	78.79

**Table 8:** Shows the t-value and significant difference for range of fundamental frequency for phonation in Hearing Impaired and normal males and females for the vowels /a/, /i/ and /u/.

	N-M Vs N-F	N-M Vs HI-M	N-F Vs HI-F	HI-M Vs HI-F
/a/ t-value	0.04	1.51	2.71	2.90
Sig-D	-	-	+	-
/i/ t-value	0.59	2.10	1.30	0.14
Sig-D	-	-	-	-
/u/ t-value	0.94	1.58	1.98	0.96
Sig-D	-	-	-	+

Tables 7 & 8 show the mean and standard deviation for range of fundamental frequency for phonation in Hearing

Impaired and normal males and females for the vowels /a/, /i/, and /u/ and the significance of the difference between the groups.

Normal males showed a mean range of 37.98 Hz; 34.34 Hz and 71.46 Hz for the vowels /a/, /i/ and /u/. The Hearing Impaired males showed a mean range of 163.44 Hz; 123.71 Hz and 96.19 Hz with greater means of frequency range for the vowels /a/, /i/ and /u/ than normal males as shown in Graphs 1,2 and 3 .

Further there was statistically significant difference between the Hearing Impaired and normal males for all the three vowels in frequency range. Normal females and Hearing Impaired females also showed statistically significant difference for all the three vowels (Table -8).

The study of Table 8 shows that the normal males and females there was no significant difference for the three vowels in terms of frequency range. The females and the males of the Hearing Impaired group also showed no significant difference for the vowels /a/ and /i/ only interms of frequency range.

Thus the hypothesis stating that there is no significant difference between males and females of the normal group in terms of frequency range in phonation is accepted. Similarly the hypothesis stating that there is no significant

difference between the males and females of the hearing impaired group is also accepted.

The review of literature on frequency range showed no studies with reference to the Hearing Impaired population. However, when compared with studies on normal population (Rashmi 1985), the Hearing Impaired population showed a large difference due to wide variations in the frequency range in each individuals production. This may be because of two reasons, one, even in the stable production of vowels due to large intensity variations in phonation, there are simultaneous variations in the pitch. Secondly, the presence of frequent pitch breaks, sometimes, towards lower frequency and sometimes higher, resulted in a wider frequency range. Thus, showing the inability of Hearing Impaired individuals to produce the vowels with steady pitch and intensity like normals.

This also shows that there is lack of laryngeal control in this population, which persists due to lack of auditory feed-back, and thus results in inappropriate variation in speech and rendering it unintelligible.

Hence focus on stabilizing the appropriate pitch as a part of therapy would be essential.

Thus the hypothesis stating that there is no significant difference between the normals and Hearing Impaired in terms



of frequency range, with reference to both males and females is rejected.

5) The Speed of Fluctuations in Fundamental Frequency (Flu/sec):

The speed of fluctuations in fundamental frequency is defined as the number of fluctuations in fundamental frequency in phonation for one second.

Table 9: Shows the mean and standard deviation of speed of fluctuations in Hearing Impaired and normal males and females for the vowels /a/, i/ and /u/.

Vowels	/a/		/i/		/u/	
Group	Mean	SD	Mean	SD	Mean	SD
N - M	11.89	5.87	10.34	3.95	8.15	3.41
HI - M	17.11	6.02	17.41	7.89	21.98	11.53
N - F	10.54	5.68	9.54	4.21	9.69	3.52
HI - F	23.84	12.62	29.69	7.24	20.31	11.49

**Table 10:** Shows the t-value and significant difference for the speed of fluctuations in Rearing Impaired normal males and females for the vowels /a/, /i/ and /u/.

	N-M Vs N-F	N-M Vs HI-M	N-F Vs HI-F	HI-M Vs HI-F
/a/ t-value	0.29	3.06	2.77	1.15
Sig-D	-	+	+	-
/i/ t-value	0.33	2.88	4.49	2.90
Sig-D	-	+	+	+
/u/ t-value	0.83	1.86	1.65	0.29
Sig-D	-	-	+	-

Table 9 shows the mean and standard deviation for the speed of fluctuations in fundamental frequency for phonation in Hearing Impaired and normal males and females for the vowels /a/, i/ and /u/

The normal males showed a mean fluctuation of 11.89 Hz; 10.34 Hz and 8.15 Hz for the vowels /a/, i/ and /u/ and Table 10 shows the results of statistical comparison of different groups for significance of difference.

The normal males showed a mean fluctuation of 11.89 Hz; 10.34 Hz and 8.15 Hz for vowels /a/, /i/ and /u/, whereas, the Hearing Impaired males showed a mean of 17.11 Hz; 17.41

Hz and 21.98 Hz. Statistically, there was a significant difference between normal males and Hearing Impaired males for the vowels /a/, /u/ and /i/. This difference is also shown by the Graphs 1, 2 and 3.

The normal females showed a mean of 10.54 Hz; 9.54 Hz and 9.69 Hz. The Hearing Impaired females showed higher mean values for the speed of fluctuation per sec. The mean values for females of Hearing Impaired group were 23.84 Hz, 29.69 Hz and 20.31 Hz. The study of Table 10 shows that as per the statistical analysis there was significant difference between normal females and Hearing Impaired females.

Thus the auxiliary hypothesis 5 stating that there is no significant difference between normal and Hearing Impaired males and females for the speed of fluctuation in frequency has been rejected.

Further a statistical analysis for significance of difference between males and females of normal group as well as the hearing impaired group showed that there was no significant difference between the two in terms of speed of fluctuations in phonation. Thus the hypothesis stating that there is no significant difference between males and females of normal and also hearing impaired groups has been accepted.

The review of literature shows no study on the speed of fluctuations in the hearing impaired population. Hence the present study cannot be compared with others. The results of

this part of the study thus further confirms the inability of the hearing impaired to control the laryngeal system during phonation and speech.

**6) Extent of fluctuations in fundamental frequency (Ext/flu):**

The extent of fluctuations in fundamental frequency is defined as variations  $\pm 3$ Hz and beyond in fundamental frequency in a given phonation .

**Table - 11:** Shows the mean and standard deviation for extent of fluctuations in frequency in hearing impaired and normal males and females for the vowels /a/, /i/ and /u/.

Vowels Group	/a/		/i/		/u/	
	Mean	SD	Mean	SD	Mean	SD
N - M	7.06	2.19	5.66	0.39	7.07	5.15
HI - M	37.95	1.60	48.47	1.44	10.91	20.89
N - F	11.89	3.12	5.83	4.20	11.98	15.02
HI - F	25.24	21.84	48	31.38	22.96	12.37

**Table - 12:** Shows the t-values and significant difference for the extent of fluctuations in frequency in hearing impaired and normal males and females for the vowels /a/, /i/ and /u/.

	N-M Vs N-F	N-M Vs HI-M	N-F Vs HI-F	HI-M Vs HI-F
/a/				
t-value	3.22	1.03	3.27	3.51
Sig-D	-	+	+	+
/i/				
t-value	5.90	1.77	3.10	0.80
Sig-D	+	+	+	-
/u/				
t-value	0.94	0.29	2.31	1.09
Sig-D	-	-	+	-

Tables 11 & 12 provide the mean and standard deviation for the extent of fluctuations in Fundamental frequency for phonation in hearing impaired and normal males and females for the vowels /a/, /i/ and /u/ and the significance of the difference between the groups respectively.

The normal males showed a mean extent of fluctuations of 7.06 Hz; 5.66 Hz & 7.07 Hz for the vowels /a/, /i/ and /u/. The Hearing Impaired males showed a mean of 37.95 Hz; 48.47 Hz & 10.91 Hz. Thus, the Hearing Impaired males showed higher mean values than the normal group as seen in Graphs 1, 2 and 3.

This was further supported by the statistical analysis that is the normal males showed extent of fluctuations in fundamental frequency in phonation which was significantly lower than that of Hearing Impaired males.

The normal females showed a mean of 11.89 Hz; 5.83 Hz and 11.98 Hz for vowels /a/, /i/ and /u/ respectively. The Hearing Impaired females showed higher mean values that is 25.24 Hz; 48 Hz and 22.96 Hz for /a/, /i/ and /u/ respectively. Thus, the normal females showed lower extent of fluctuations in fundamental frequency when compared to hearing impaired. This is also evident from the Graphs 1, 2 and 3. Statistical analysis also showed that the difference was significant i.e., the Hearing Impaired females had significantly higher extent of fluctuations than the normal females.

The study of table 12 shows that there is significant difference between normal males Vs Hearing Impaired males for the vowels /a/ and /i/ respectively. Further, the statistical analysis shows that there is significant difference between the normal females and the Hearing Impaired females. This can be attributed to the fact that the Hearing Impaired lack the laryngeal control thus, leading to inappropriate variations in phonation.

The study of Table 12 shows that the normal males and females there was no significant difference for the three vowels in terms of extent of fluctuations in fundamental

## FUNDAMENTAL FREQUENCY /a/

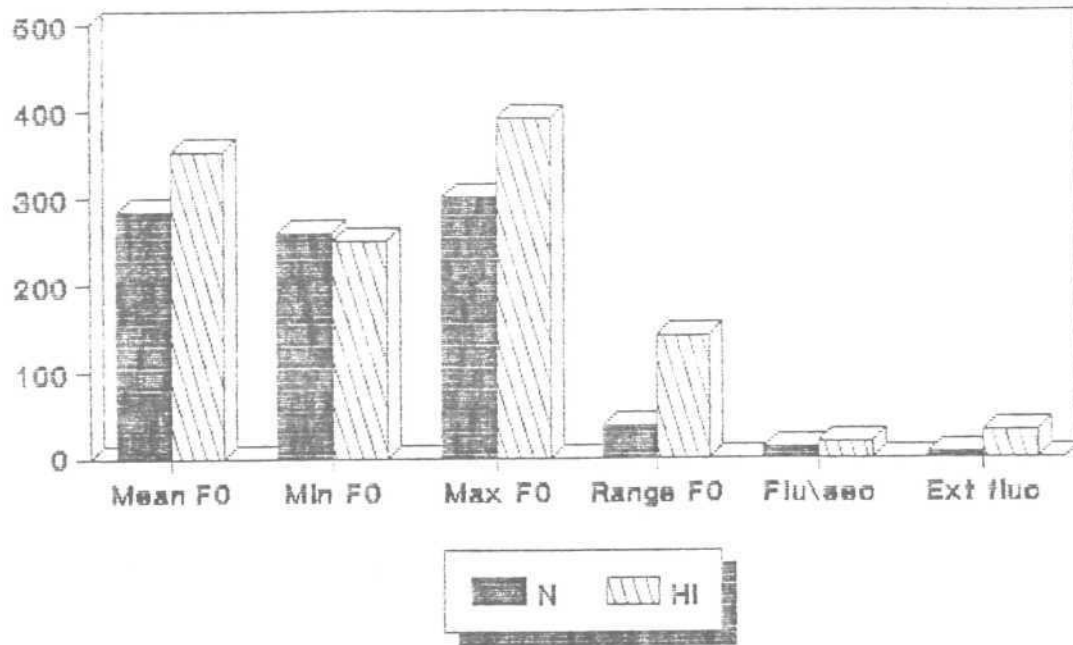

Graph-1: Shows the mean Fundamental Frequency measures for normals (N) and hearing-impaired (HI) subjects for the vowel /a/.

## FUNDAMENTAL FREQUENCY /i/

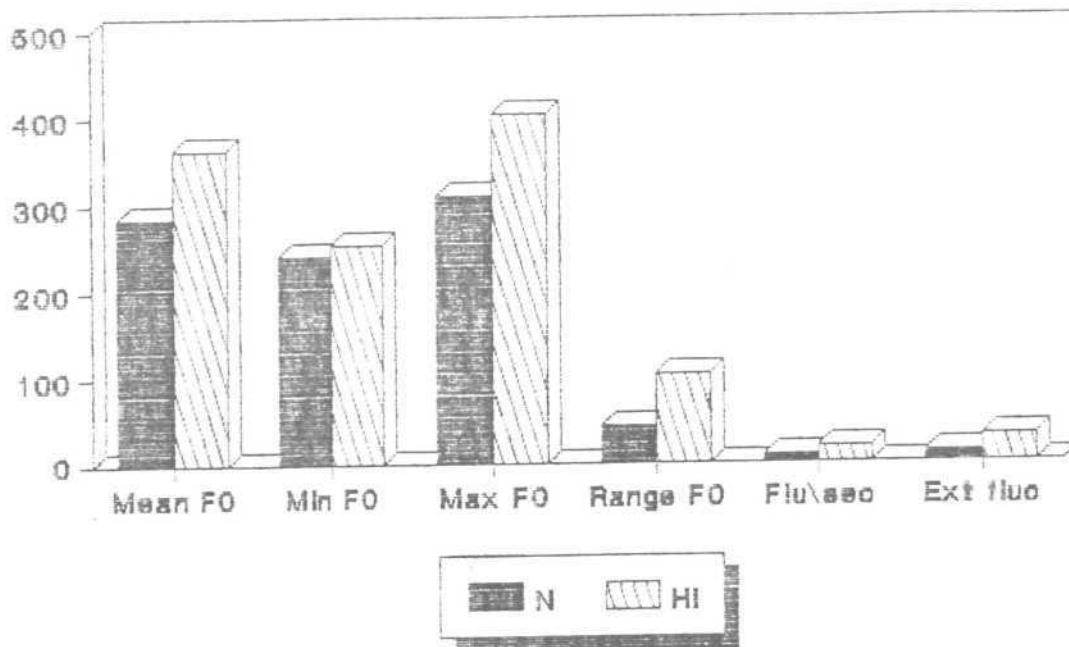

Graph-2: Shows the mean Fundamental Frequency measures for normals (N) and hearing-impaired (HI) subjects for the vowel /i/.



## FUNDAMENTAL FREQUENCY /u/

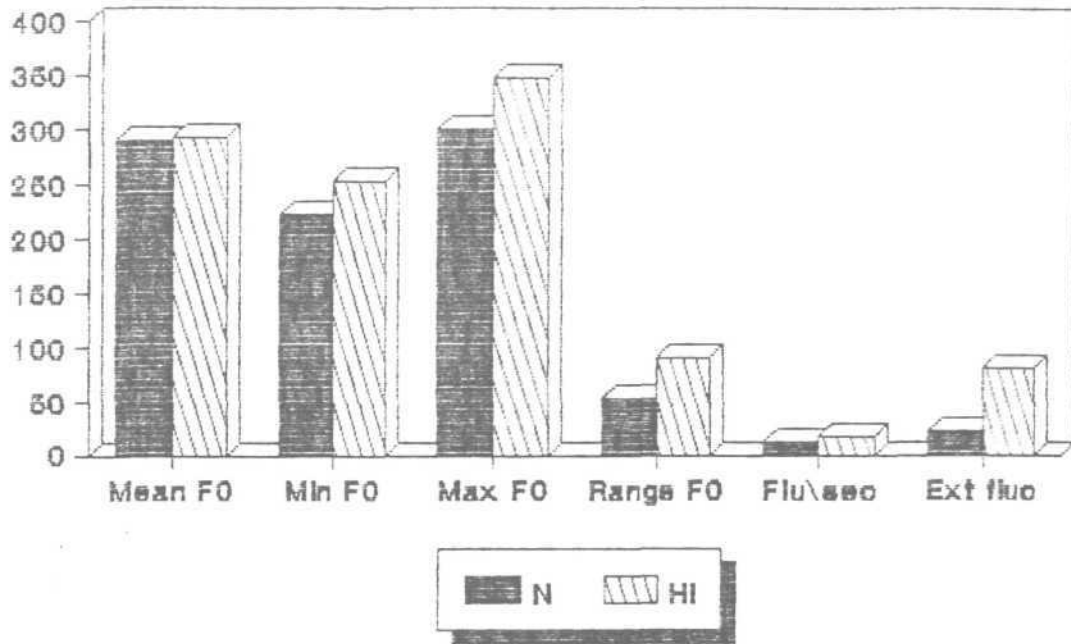

Graph-3: Shows the mean Fundamental Frequency measures for normals (N) and hearing-impaired (HI) subjects for the vowel /u/.

frequency except for vowel /i/. The females and the males of the Hearing Impaired group also showed no significant difference except for for the vowel /a/ in terms of extent of fluctuations in fundamental frequency .

Thus the hypothesis stating that there is no significant difference between males and females of the normal group in terms of extent of fluctuations in fundamental frequency in phonation is accepted. Similarly the hypothesis stating that there is no significant difference between the males and females of the hearing impaired group in terms of extent of fluctuations in fundamental frequency is also accepted.

Intensity Measures :

(1) Mean Intensity in Phonation (Mean A<sub>0</sub>) :

Mean intensity level is defined as the mean amplitude of the steady portion of the phonation.

**Table 13:** Shows the mean and standard deviation (SD) of mean intensity for phonation in hearing impaired and normal males and females for the vowels /a/, /i/ and /u/.

Vowels	/a/		/i/		/u/	
Group	Mean	SD	Mean	SD	Mean	SD
N - M	46.66	8.71	52.53	7.24	53.39	18.83
HI - M	45.81	7.28	36.87	7.06	45.75	7.89
N - F	44.46	4.35	49.58	10.05	44.62	4.17
HI - F	42.18	9.86	45.53	16.42	44.11	6.86

**Table 14:** Shows the t-values and significant differences for mean intensity of the phonation in hearing impaired and normal males and females for the vowel /a/, /i/ and /u/.

	N-M Vs N-F	N-M Vs HI-M	N-F Vs HI-F	HI-M Vs HI-F
/a/ t-value	0.53	0.76	0.55	0.56
Sig-D	-	-	-	-
/i/ t-value	0.52	1.52	2.75	1.30
Sig-D	-	-	+	+
/u/ t-value	0.88	1.66	3.83	0.78
Sig-D	-	-	+	-

Tables 13 and 14 indicate the mean and standard deviation of the mean intensity in phonation of vowels /a/, /i/ and /u/ and significance of the difference between the means of each group respectively.

The normal males showed a mean intensity of 46.66 dB, 52.53 dB and 53.39 dB respectively for vowels /a/, /i/ and /u/, where as the hearing impaired males showed a mean of 45.81 dB; 36.87 dB and 45.75 dB.

The normal females showed a mean intensity of 44.46dB ; 49.58dB and 44.62dB for the vowels /a/, /i/ and /u/, where as the hearing impaired females showed a mean intensity of 42.18dB , 45.53dB and 44.11dB as shown in Graphs 4, 5 and 6.

There was no significant difference between hearing impaired and normal males for the vowels /a/, /i/ and /u/. There was no significant difference for /i/ and /u/ but /a/ did show significant difference in case of females of normal and hearing impaired groups. Thus accepting the hypothesis (i) that "there is no significant difference between males of normal and hearing impaired and females of the normal and hearing impaired groups with reference to mean intensity level in phonation". This may be due to control introduced while recording to avoid distortion of the signal recorded.

Further a statistical analysis for significance of difference between males and females of normal group showed that there was no significant difference between the

two in terms of the minimum intensity in phonation. Similarly in the hearing impaired group the comparison between the males and females showed that there was no significant difference between the two in terms of the mean intensity in phonation except for vowel /i/. Thus the hypothesis stating that there is no significant difference between males and females of normal and also hearing impaired groups in terms of the mean intensity in phonation has been accepted.

**(2) Maximum Intensity in Phonation :**

It is defined as the maximum intensity measured in the study portion of phonation.

**Table 15:** Shows the mean and standard deviation of maximum intensity for phonation in Hearing Impaired and Normal males and females for the vowels /a/, /i/ and /u/.

Vowels	/a/		/i/		/u/	
	M	SD	M	SD	M	SD
N-M	54.29	5.60	55.45	5.95	49.41	17.47
HI-M	49.96	6.66	51.81	5.50	53.08	5.54
N-F	51.69	5.04	53.96	6.49	54.82	5.82
HI-F	45.82	7.12	32.43	3.91	51.82	6.92

**Table 16:** Shows the T-values and significant difference for maximum intensity for phonation in Hearing Impaired and Normal males and females for the vowels /a/, /i/ and /u/.

	N-M Vs N-F	N-M Vs HI-M	N-F Vs HI-F	HI-M Vs HI-F
/a/ t-value	0.91	0.01	0.27	0.55
Sig-D	-	-	-	-
/i/ t-value	0.33	0.98	3.94	3.94
Sig-D	-	-	+	+
/u/ t-value	0.72	0.51	13.31	13.30
Sig-D	-	-	+	+

Tables 15 & 16 shows the mean and standard deviation of maximum intensity for phonation in hearing impaired and normal males and females for the vowels /a/, /i/ and /u/ and the significance of the difference between the means of each group.

The normal males showed the mean maximum intensity of values of 54.29dB ; 55.45dB and 49.41dB for the vowels /a/, /i/ and /u/. Where as the hearing impaired males showed a mean of 49.96dB , 51.81dB & 53.08dB.

The normal females showed a maximum intensity of 51.69dB; 53.96dB and 54.82dB for the vowels /a/, /i/ & /u/, where as the hearing impaired females showed the maximum intensity of 45.82dB , 32.43dB & 51.92dB as shown in Graphs 4, 5 & 6.

There was no significant difference between hearing impaired males and normal males for the vowels /a/, /i/ & /u/. However there was significant difference between hearing impaired females and normal females for the vowels /a/, /i/ & /u/ for maximum intensity.

However, there were individual variations as compared with normals. probably indicating the lack of control in monitoring the intensity of phonation. The hearing impaired had mean intensity which ranged from 30.96dB to 51.39dB.

Further a statistical analysis for significance of difference between males and females of normal group as well as the hearing impaired group showed that there was no significant difference between the two in terms of the maximum intensity in phonation. Thus the hypothesis stating that there is no significant difference between males and females of normal and also hearing impaired groups in terms of the maximum intensity in phonation has been accepted.

3). **Minimum intensity:** It is defined as the minimum intensity of the steady portion of phonation.

**Table 17:** Shows the mean and standard deviation (SD) for minimum intensity for phonation in Hearing Impaired and normal males and females for the vowels /a/, /i/ and /u/.

Vowel	/a/		/i/		/u/	
	M	SD	M	SD	M	SD
N-M	32.35	14.83	43.16	9.20	46.83	10.94
HI-M	33.35	15.32	31.55	8.44	35.49	9.52
N-F	31.10	9.72	34.17	16.56	41.40	13.84
HI-F	28.18	9.72	44.87	7.32	33.43	12.84

**Table 18:** Shows the t-value and significant difference for minimum intensity for phonation in Hearing Impaired and normal males and females for the vowels /a/, /i/ and /u/.

	N-M Vs N-F	N-M Vs HI-M	N-F Vs HI-F	HI-M Vs HI-F
/a/ t-value	0.13	0.56	0.39	1.17
Sig-D	—	—	—	—
/i/ t-value	1.15	0.98	0.27	1.01
Sig-D	—	—	—	—
/u/ t-value	0.53	1.67	0.91	0.50
Sig-D	—	—	—	—



Tables 17 & 18 show the mean and standard deviation for minimum intensity for phonation in Hearing Impaired and normal groups, both males and females for the vowels /a/, /i/ and the results of statistical analysis regarding /u/ and significance of the difference between the means of different groups, respectively.

Normal males showed a minimum intensity of 32.35 dB; 43.16dB and 46.83 dB for the vowels /a/, /i/ and /u/. Where as the Hearing Impaired males showed a mean of 31.55 dB; 33.35 dB and 35.49 dB for /a/, /i/ and /u/ respectively.

Mean minimum intensities of 31.10 dB; 34.17 dB and 41.40 dB were seen in the phonateion of normal females. Where as the Hearing Impaired females showed a mean minimum intensities of 28.18 dB; 44.87 dB and 33.43 dB for /a/, /i/ and /u/. Graphs 4, 5 and 6 depict these results.

No studies were available to the present investigator regarding the minimum intensity for the Hearing Impaired populations.

The study of the Table 18 shows that there is no significant difference between the normal males and Hearing Impaired males. Further the statistical analysis showed that there was no significant difference between the normal females and Hearing Impaired females.

Thus the axillary hypothesis stating that there is no significant difference between normal and Hearing Impaired and males with reference to the minimum intensity has been accepted. Further the hypothesis stating that there is no significant difference in terms minimum intensity between females of normal and hearing impaired groups has been accepted, as shown by the Table-18.

A statistical comparison of females and males of the normal group interms of minimum intensity shows that there is no significant difference between the two. Similarly the females and males of the Hearing impaired group also showed no significant difference between the two.

Thus the hypothesis stating that there is no significant difference, in terms of minimum intensity, between the females and males of both the normal as well as hearing impaired groups was accepted.

#### 4) . Range of Intensity in phonation (Range A<sub>o</sub>) :

This has been defined as the difference between maximum and minimum intensity in phonation.

**Table 19:** Shows the mean and standard deviation (SD) for range of intensity for phonation in Hearing Impaired and normal males and females for the vowels /a/, /i/ and /u/.

Vowel	/a/		/i/		/u/	
Group	M	SD	M	SD	M	SD
N-M	20.62	14.83	20.79	9.20	13.78	10.94
HI-M	17.53	11.36	18.53	10.99	18.00	6.64
N-F	21.24	9.71	8.63	16.56	9.57	13.84
HI-F	23.87	2.81	18.78	4.34	19.65	15.00

**Table 20:** Shows the t-value and significant difference for range of intensity for phonation in Hearing Impaired and normal males and females for the vowels /a/, /i/ and /u/.

	N-M Vs N-F	N-M Vs HI-M	N-F Vs HI-F	HI-M Vs HI-F
/a/ t-value	0.87	0.32	5.07	1.23
Sig-D	–	–	+	–
/i/ t-value	1.39	1.43	8.33	0.84
Sig-D	–	–	+	–
/u/ t-value	0.47	0.99	3.34	0.24
Sig-D	–	–	+	–

Table 19 shows the mean and standard deviation for range of intensity for phonation in Hearing Impaired and normal, (both males and females) for the vowels /a/, /i/ and /u/.

The normal males showed a mean range of 20.62dB; 20.79dB 13.78dB where as, the Hearing Impaired males showed a mean of 17.53dB; 18.53dB and 18.00dB for /a/, /i/ and /u/ respectively. The range varied from a minimum of 31.10dB to a maximum of 51.69dB in males of hearing impaired group.

Mean ranges of 21.24dB; 16.56dB; 13.84dB and 23.87dB; 18.78dB; 19.65dB were presented by the females of normals and Hearing impaired respectively. These results are shown in the Graphs 4, 5 & 6 also.

Further a study of Table-20 showed that there was significant difference for only between normal females and females of Hearing Impaired for the vowels /a/, /i/ and /u/.

However the individual variations were wider (4-24 dB) in Hearing Impaired group as compared with normals, indicating the lack of control in monitoring the intensity of phonation. This factor i.e., monitoring intensity during phonation and thus in speech, must also be considered during therapy with Hearing Impaired individuals.

The study of Table-20 shows that there is no significant difference between normal males and females in terms of intensity range. A comparison of males and females

of Hearing Impaired group showed that there was no significant difference between two for three vowels /a/, /i/ and /u/ in terms of intensity range. Thus the hypothesis stating that there is no significant difference between the males and females of normal as well as hearing impaired groups was accepted.

#### 5). Speed of fluctuation (Flu/sec):

The speed of fluctuation in intensity was defined as the number of fluctuations in intensity in phonation of per second.

**Table 21:** Shows the mean and standard standard deviation (SD) for the speed of fluctuation in intensity for phonation in Hearing Impaired normal males and females for the vowels /a/, /i/ and /u/.

Vowel	/a/		/i/		/u/	
Group	M	SD	M	SD	M	SD
N-M	20.62	3.63	20.79	4.63	13.78	3.01
HI-M	17.83	5.49	18.83	4.86	18.00	6.77
N-F	21.24	5.93	16.56	2.44	13.84	2.02
HI-F	23.87	5.82	18.78	0.93	19.65	6.33

Table 22: Shows the t-values and significant difference for the speed of fluctuations in intensity for phonation in Hearing Impaired and normal males and females for the vowels /a/, /i/ and /u/.

	N-M Vs N-F	N-M Vs HI-M	N-F Vs HI-F	HI-M Vs HI-F
/a/ t-value	0.55	1.02	0.83	0.72
Sig-D	-	-	-	-
/i/ t-value	1.79	1.54	12.01	0.88
Sig-D	-	-	+	-
/u/ t-value	0.12	1.96	11.13	0.82
Sig-D	-	-	+	-

Tables 21 & 22 indicate the mean and standard deviation for the speed of fluctuation in intensity for phonation in Hearing Impaired and normal males and females for the vowels /a/, /i/ and /u/ and the significance of the differences between the groups respectively.

The normal males showed mean fluctuations of 20.62dB; 20.79dB and 13.7dB and the Hearing Impaired males showed mean of 17.83dB; 18.83dB and 18dB respectively. There was no statistically significant difference between these two groups. Graphs 4, 5 and 6 also depict the difference between groups.

Normal and Hearing Impaired females showed mean fluctuations of 21.24 dB, 16.56dB and 13.84 dB and the

Hearing Impaired females showed mean values of 23.87dB, 18.78dB and 19.65dB respectively for /a/, /i/ and /u/. Thus the Hearing Impaired females showed higher fluctuation for the vowels /a/, /i/ and /u/ than normal females. There was significant difference between Hearing Impaired females and normal females except for /a/.

Thus the hypothesis stating that there is no significant difference between normal males and males of the hearing impaired group for the speed of fluctuations in intensity has been accepted. Further the hypothesis stating that there is no significant difference between the females of the hearing impaired group and the normal group in terms of speed of fluctuations in intensity has been rejected.

The females and males of normal group did not show statistically significant difference as depicted in Table-22. Further the study of Table-22 also shows that there is no significant difference between the males and females of the hearing impaired population in terms of speed of fluctuations

Thus the hypothesis stating that there is no significant difference between normal males and females for the speed of fluctuations in intensity has been accepted. Further the hypothesis stating that there is no significant difference between the males and females of the hearing impaired group in terms of speed of fluctuations in intensity has been accepted.

6). **Extent of fluctuation in intensity (Ext flu):**

**Table 23:** Shows the mean and standard deviation for the extent of fluctuation in intensity of a phonation in Hearing Impaired and normal males and females for the vowels /a/, /i/ and /u/.

Vowel	/a/		/i/		/u/	
Group	M	SD	M	SD	M	SD
N-M	3.72	2.74	1.91	1.83	2.76	1.86
HI-M	3.40	0.55	3.70	0.18	3.94	1.09
N-F	3.46	1.40	3.58	2.44	2.34	1.84
HI-F	3.94	0.62	3.56	0.29	3.50	0.81

**Table 24:** Shows the t-values and significant difference for the extent of fluctuation in intensity for phonation in Hearing Impaired and normal males and females for the vowels /a/, /i/ and /u/.

	N-M Vs N-F	N-M Vs HI-M	N-F Vs HI-F	HI-M Vs HI-F
/a/ t-value	0.21	0.29	2.75	0.83
Sig-D	—	—	+	—
/i/ t-value	1.24	2.18	16.97	0.96
Sig-D	—	—	+	—
/u/ t-value	3.00	2.12	1.21	0.72
Sig-D	—	—	—	—



Tables 23 and 24 provide the mean and standard deviation for the extent of fluctuation in intensity for phonation in Hearing Impaired and normal males and females for the vowels /a/, /i/ and /u/ and the significant of the difference between the groups respectively. Further the means are depicted in Graphs 4, 5 and 6 respectively.

Normal males showed a mean extent of fluctuation of 3.72dB; 1.99dB and 2.76dB for the vowels /a/, /i/ and /u/. The Hearing Impaired males showed a mean of 3.40dB; 3.70dB and 3.94dB for the vowels /a/, /i/ and /u/ respectively. Statistically, there was no significant difference between males of the two groups. The extent of fluctuation in intensity were relatively less than fluctuation in fundamental frequency.

The normal females showed a mean of 3.46dB; 3.58dB and 2.34dB for the vowels /a/, /i/ and /u/, whereas the Hearing Impaired showed mean of 3.94dB; 3.56dB and 3.50dB for /a/, /i/ and /u/ respectively. There was significance difference for the vowels /a/, /i/ and no significant difference for /u/ between the females of the two groups.

Thus the hypothesis stating that there is no significant difference between the normal and Hearing Impaired males for the extent of fluctuation in intensity has been accepted. However, the hypothesis stating that there is no significant difference between normal females and hearing impaired

females for the extent of fluctuations in intensity has been rejected except for /u/.

The study of Table-24 females and males of normal group did not show statistically significant difference in terms of extent of fluctuations in intensity.

Further it also shows that there is no significant difference between the males and females of the hearing impaired population in terms of extent of fluctuations in intensity.

Thus the hypothesis stating that there is no significant difference between normal males and females for the extent of fluctuations in intensity has been accepted. Further the hypothesis stating that there is no significant difference between the males and females of the hearing impaired group in terms of extent of fluctuations in intensity has also been accepted.

Thus, the hypothesis (I) has been rejected i.e., there is no significant difference between normals and Hearing Impaired males and females in the fundamental frequency and intensity measures of vowels /a/, /i/ and /u/.

## INTENSITY PARAMETERS /a/

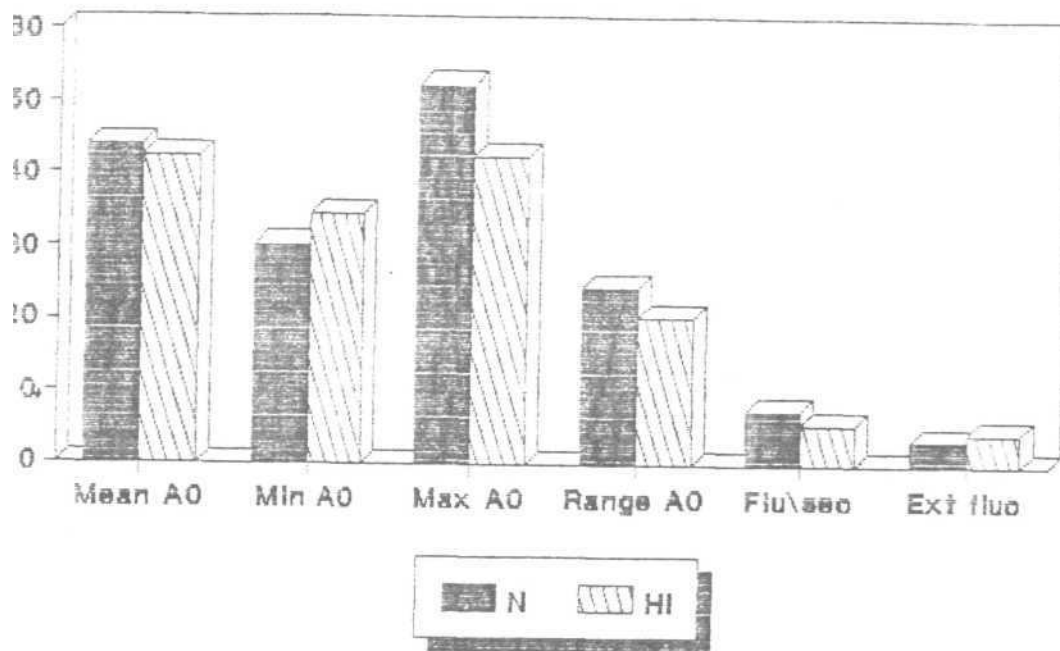

Graph-4 Shows the mean Intensity Measures for normals (N) and hearing-impaired (HI) subjects for the vowel /a/.

## INTENSITY PARAMETERS /i/

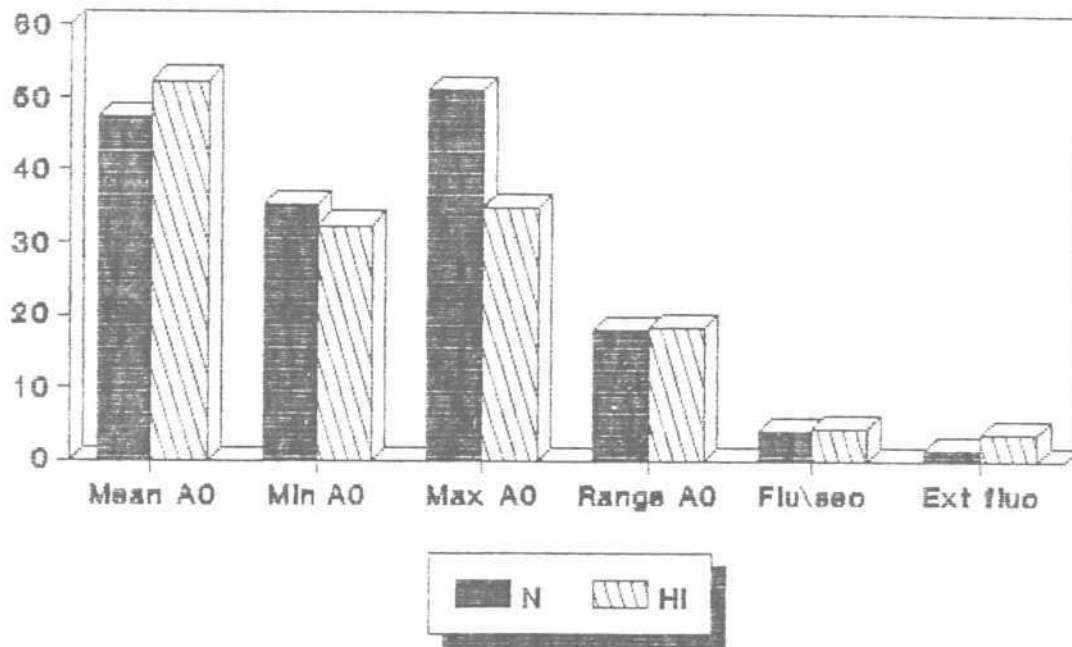

Graph-5 Shows the mean Intensity Measures for normals (N) and hearing-impaired (HI) subjects for the vowel /i/.

## INTENSITY PARAMETERS /u/

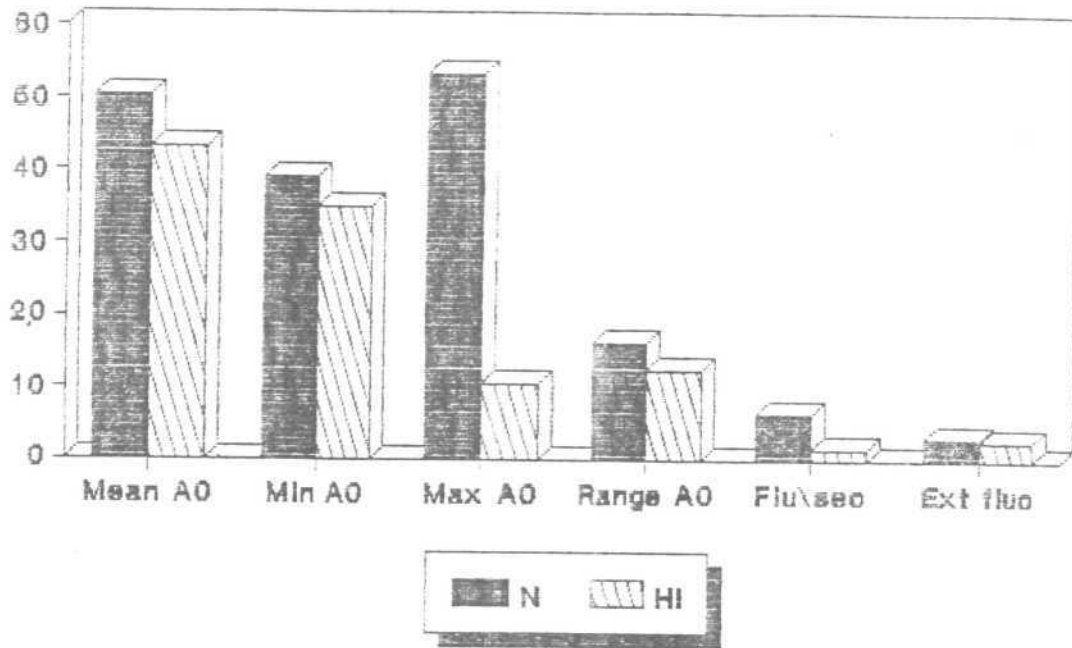

Graph-6 Shows the mean Intensity Measures for normals (N) and hearing-impaired (HI) subjects for the vowel /u/.

**EGG MEASURES:**

1) **Open Quotient (OQ)** : Open Quotient is the ratio between the open phase to the total vibratory cycle.

$$OQ = \frac{\text{Open Phase}}{\text{Vibratory period}}$$

**Table 25:** Shows the mean and standard deviation for open quotient in Hearing Impaired and Normal males and females for the vowels /a/, /i/ and /u/.

Vowels	/a/		/i/		/u/	
Group	M	SD	M	SD	M	SD
N-M	0.58	0.46	0.66	0.47	0.74	0.65
HI-M	0.40	0.10	0.36	0.66	0.61	0.82
N-F	0,68	0.94	0.69	0.51	0.68	0.49
HI-F	0.37	0.10	0.36	0.75	0.52	0.43

**Table 26:** Shows the T-values and significant difference for the open quotient in Hearing Impaired and Normal males and females for the vowels /a/, /i/ and /u/.

	N-M Vs N-F	N-M Vs HI-M	N-F Vs HI-F	HI-M Vs HI-F
/a/ t-value	0.32	3.92	2.86	0.47
Sig-D	—	—	+	—
/i/ t-value	8.14	1.23	3.43	0,84
Sig-D	—	—	+	—
/u/ t-value	1.04	0.27	0.28	0.23
Sig-D	—	—	—	—

Open Quotient in normal males showed a mean of .58; .66 and .74 for the vowels /a/, /i/ and /u/ with a standard deviation of 0.46; 0.47 and 0.65. The hearing impaired showed a mean of .40; 0.36 and 0.61 with a standard deviation of 0.10, 0.66 and 0.82 for the vowels /a/, /i/ and /u/ as shown in Table25 and Graphs 7, 8 and 9.

The statistical analysis showed significant differences for between the normals males and hearing impaired males for the vowel /a/ only.

In normal female subjects, the OQ for the vowels /a/, /i/ and /u/ showed a mean of 0.68; 0.94 and 0.68 respectively with a standard deviation of 0.94; 0.51 and 0.49. The hearing impaired females showed a mean OQ of .37; .36 and .52 as shown in Tables 25 Graphs 7, 8 and 9 respectively.

There was significant differences between the Hearing Impaired females and normal females for the vowels /a/ and /i/ only and not for /u/.

In general it can be said that the OQ in hearing impaired was lower than in normal subjects in both males and females. This implies that in the hearing impaired the duration of the vibratory cycle for which the glottis is open was less than in normals.

It was observed that there was no significant difference between normal males and females. Further the statistical analysis showed that there was no significant difference between Hearing Impaired males and Hearing Impaired females.

Thus the Auxiliary Hypothesis stating the there is no significant difference between males and females of normal and Hearing Impaired groups in terms of open quotient has been accepted.

Timcke et al., (1950) stated that, "a small OQ describes a condition in which strong, short glottal pulses excite the vocal tract to resonate high harmonics; the sharper the puff, the richer the glottal wave in the high frequency components of high harmonics characterize acoustically powerful efficient vocal tones. The presence of the number of harmonics need to be studied in the light of the above report and findings of the present study.



**Speed index (SI):**

Speed index is obtained by

$$SI = \frac{\text{Opening phase} - \text{Closing phase}}{\text{Opening phase} + \text{Closing phase}}$$

$$\text{that is } SI = \frac{SQ - 1}{SQ + 1}$$

**Table 27:** Shows the mean & standard deviation (SD) for the speed index in the hearing impaired & normal males & females for the vowels /a/, /i/ & /u/.

Vowels	/a/		/i/		/u/	
Groups	M	SD	M	SD	M	SD
N-M	0.46	0.14	0.36	0.80	0.38	0.57
HI-M	0.38	0.23	0.43	0.94	0.49	0.82
N-F	0.48	0.81	0.35	1.59	0.49	0.92
HI-F	0.37	0.07	0.83	0.71	0.51	0.04

**Table 28:** Shows the t-value and significant difference for the speed index in the hearing impaired & normal males & females for the vowels /a/, /i/ and /u/.

	N-M Vs N-F	N-M Vs HI-M	N-M Vs HI-F	HI-M Vs HI-F
/a/ T-Value	.66	.86	.97	.41
Sig-D-		-	-	-
/i/ T-value	.58	1.06	.77	1.62
Sig-D-		-	-	-
/u/ T-Value	1.24	.61	1.30	.75
Sig-D-		-	-	-

Normal males showed a mean of .46; .36 and .38 for the vowels /a/, /i/ and /u/ respectively. The hearing impaired males showed a mean of 0.38; 0.43 and 0.82, as shown in Table 29 and Graphs 7,8 and 9.

Statistical/ there was no significant difference between males of the two groups for the vowels /a/, /i/ & /u/.

In normal females the SI for the vowels /a/, /i/ and /u/ showed a mean of 0.4; 0.35 and 0.49 respectively. Their standard deviations were 0.81; 1.59 and 0.92. The hearing impaired - females showed a mean of 0.38; .83 and 0.51 with a standard deviation of 0.07; 0.07 and 0.04 respectively. There was no statistical/ significant difference between females

the two groups for all the three vowels /a/, /i/ & /u/ as shown in Tables 28 and graphs 7, 8 and 9.

It was observed that there was no significant difference between normal males and hearing impaired males in terms of Speed index. Further the statistical analysis showed that there was no significant difference between Hearing Impaired females and normal females in terms of Speed Index.

Thus the Auxiliary Hypothesis stating that there is no significant difference between males of normal and Hearing Impaired groups in terms of speed Index has been accepted. Further, the Hypothesis stating that there is no significant difference between females of normal and Hearing Impaired groups in terms of Speed Index has also been accepted.

It was observed from the study of Table-27 that there was no significant difference between normal males and females. Further the statistical analysis also showed that there was no significant difference between Hearing Impaired males and Hearing Impaired females in terms of Speed Index.

Thus the hypothesis stating that there is no significant difference between males and females of normal and Hearing Impaired groups in terms of speed Index has been accepted.

3) **Speed Quotient (SQ)** : Speed Quotient is the ratio between the opening time to the closing time in a vibratory cycle i.e.,

$$SQ = \frac{\text{Opening Time}}{\text{Closing time}}$$

**Table 29:** Shows the mean and standard deviation (SD) for the speed quotient (SQ) for in the hearing impaired and normal males and females for the vowels /a/, /i/ & /u/.

Vowels	/a/		/i/		/u/	
Groups	M	SD	M	SD	M	SD
N-M	2.19	1.44	1.34	1.79	1.79	1.66
KI-M	1.65	0.86	1.69	0.09	2.08	0.83
N-F	2.40	1.83	2.3	1.32	2.58	0.95
HI-F	1.93	0.58	1.78	1.07	1.22	0.95

**Table 30:** Shows the T-value and significant difference for the speed quotient (SQ) for the hearing impaired and normal males and females for the vowels /a/, /i/ and /u/.

	N-M Vs N-F	N-M Vs HI-M	N-M Vs HI-F	HI-M Vs HI-F
/a/ T-Value Sig-D	.69 —	1.97 —	6.99 —	.64 —
/i/ T-value Sig-D	38 —	1.98 —	.86 —	.26 —
/u/ T-Value Sig-D	.53 —	1.27 —	1.02 —	1.27 —

SQ in normal males indicated a mean of 2.19; .86 and 1.79 for the vowels /a/, /i/ & /u/ with a standard deviation 1.44; 1.34 and 1.66. The hearing impaired males showed a mean of 1.65; 1.69 and 2.08 with a standard deviation of 0.86; 0.09 and 0.83 for the vowels /a/, /i/ & /u/ as shown in Tables 29 and graphs 7, 8 and 9.

The statistical analysis showed no significant differences between the two groups for all the vowels /a/, /i/ and /u/.

In normal females, the SQ for the vowels /a/, /i/ and /u/ showed a mean of 2.40; 2.3 and 2.58 with a standard deviation of 1.83; 1.32 and 0.95. The hearing impaired

females showed a mean of 1.93; 1.78 and 1.22 with a standard deviation of 0.58; 1.07 and 1.22. There was no statistically significant difference between the females of the two groups.

Thus the hypothesis stating that there is no significant difference between males of normal and the hearing impaired groups in terms of speed quotient is accepted. Similarly the hypothesis stating that there is no significant difference between females of normal and the Hearing Impaired groups in terms of Speed quotient is also accepted.

Table 30 shows that there is no significant difference between normal males and normal females in terms of speed quotient. Further statistical analysis shows that there is also no significant difference between the Hearing Impaired males and Hearing impaired females with reference to speed quotient.

Thus the hypothesis stating that there is no significant difference between normal males and females of normal group in terms of speed quotient is accepted. Similarly the the hypothesis that there is no significant difference between males and females of the Hearing Impaired groups is also accepted.

These findings, that there is no significant between the SQ in the hearing impaired and normal subjects, may be because the loudness of phonation between the two groups may be comparable and study by Timcke et al., (1958) has revealed

that "as the loudness increased the lateral displacement of the vocal folds also increased, as they were blown more vigorously apart".

#### 4) "S" Ratio (SR) :

$$SR = \frac{\text{Area occupied by contact phase (C)}}{\text{Area occupied by open phase (O)}}$$

**Table 31:** Shows the mean and Standard deviation (SD) for S-ratio hearing impaired and normal males and females for the vowels /a/, /i/ and /u/.

Vowels	/a/		/i/		/u/	
Groups	M	SD	M	SD	M	SD
N-M	1.13	0.10	1.14	0.13	1.15	0.12
HI-M	1.05	0.26	1.23	0.32	1.03	0.26
N-F	1.08	0.16	1.09	0.06	1.14	0.13
HI-F	1.06	0.43	1.08	0.35	1.07	0.32

**Table 32:** Shows the t-value and significant difference for the "S" Ratio for the hearing impaired and normal males and females for the vowels /a/, /i/ and /u/.

	N-M Vs N-F	N-M Vs HI-M	N-M Vs HI-F	HI-M Vs HI-F
/a/ T-Value	.34	.65	.35	.43
Sig-D	—	—	—	—
/i/ T-value	.59	.73	.25	.39
Sig-D	—	—	—	—
/u/ T-Value	.39	.93	.48	.43
Sig-D	—	—	—	—

The normals males showed a mean of 1.13; 1.14; and 1.15 with the standard deviation of 0.10; 0.13 and 0.12. The hearing impaired males showed a mean of 1.05; 1.23 and 1.03 with the standard deviation of 0.26; 0.32 and 0.26 as shown in Table 31.

There was no statistically significant difference between the two groups that is the hearing impaired males and normal males for the vowels /a/, /i/ and /u/ as shown in Table 32.

In normal females the mean values were 1.08; 1.09 and 1.14 with a standard deviation of 0.16; 0.06 and 0.13 for /a/, /i/ and /u/ respectively. The hearing impaired females



## EGG PARAMETERS /a/

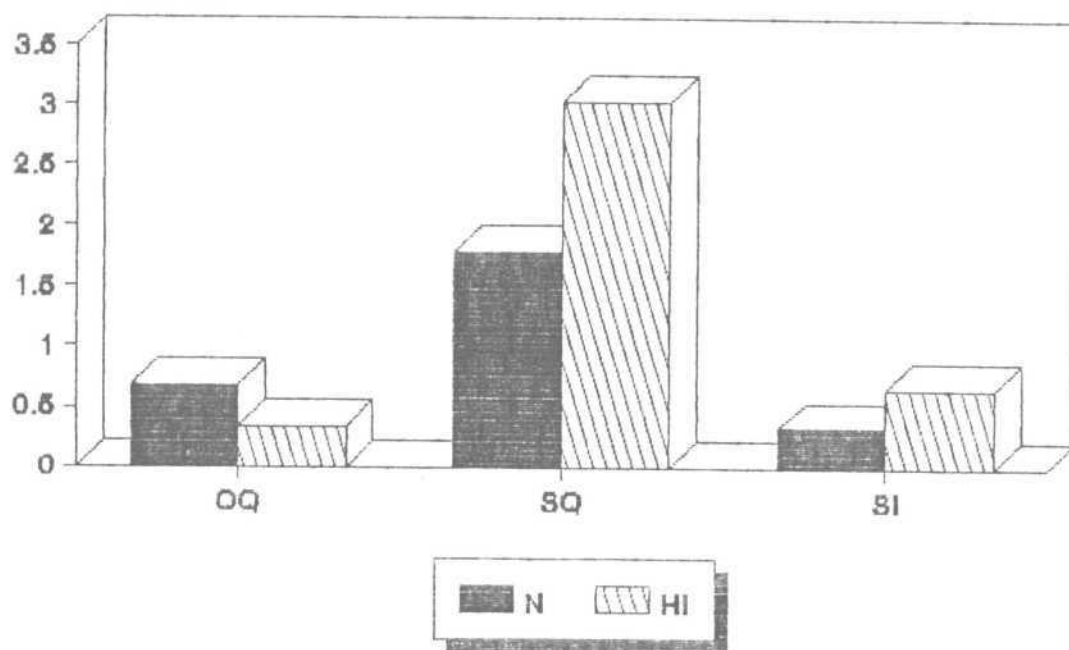

Graph-7 Shows the mean EGG Measurements for normals (N) and hearing-impaired (HI) subjects for the vowel /a/.

## EGG PARAMETERS /i/

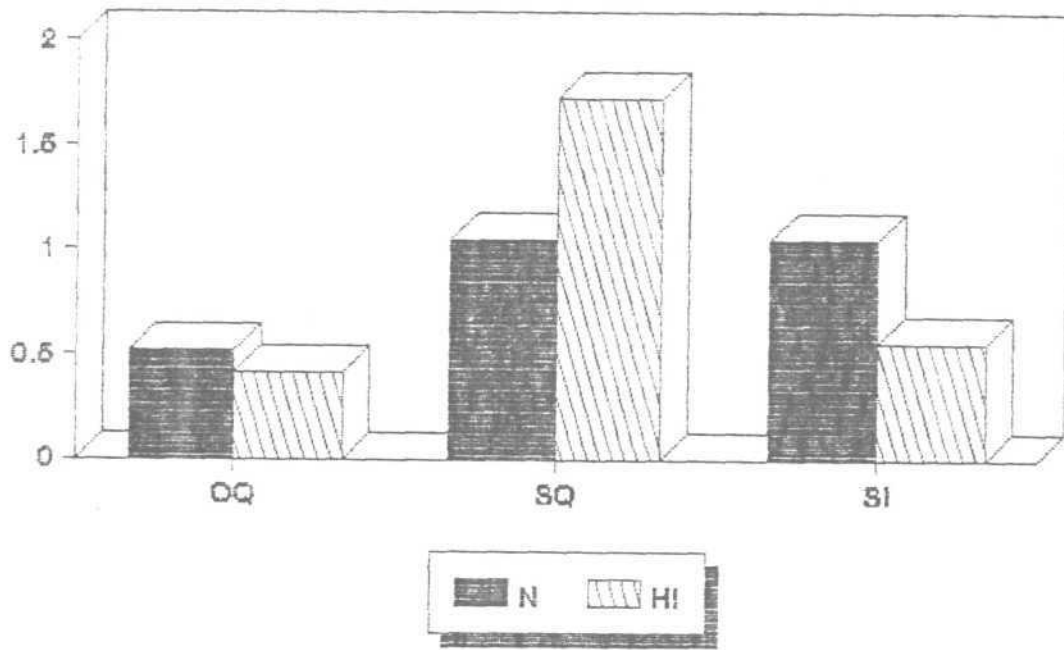

Graph-8 Shows the mean EGG Measurements for normals (N) and hearing-impaired (HI) subjects for the vowel /i/

## EGG PARAMETERS /u/

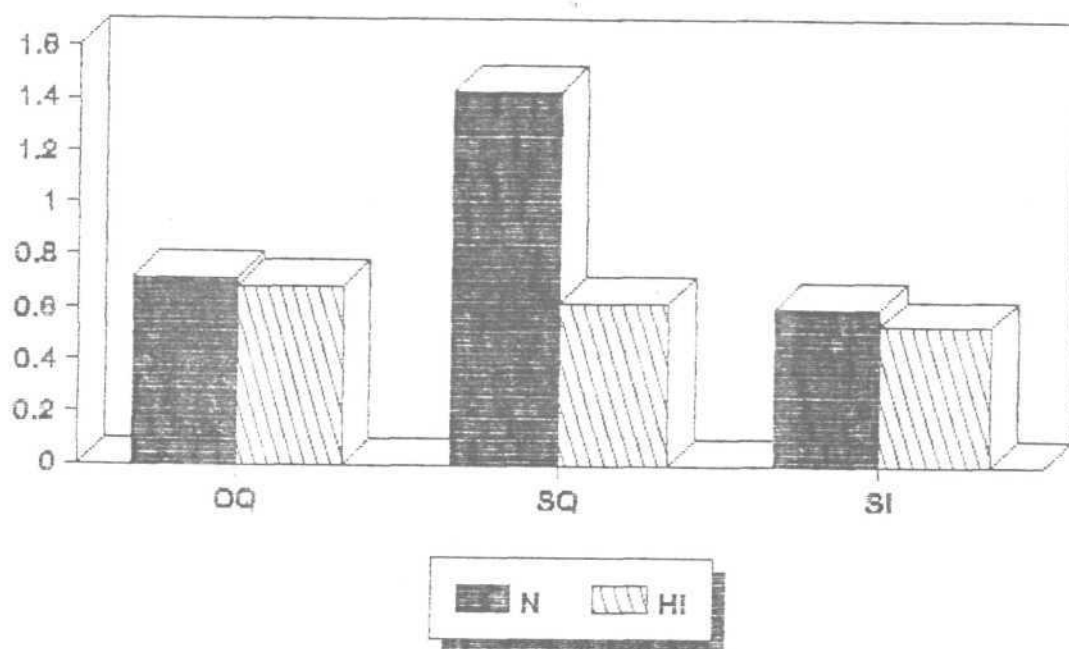

Graph-9 Shows the mean EGG Measurements for normals (N) and hearing-impaired (HI) subjects for the vowel /u/.

### Means of "S" Ratio

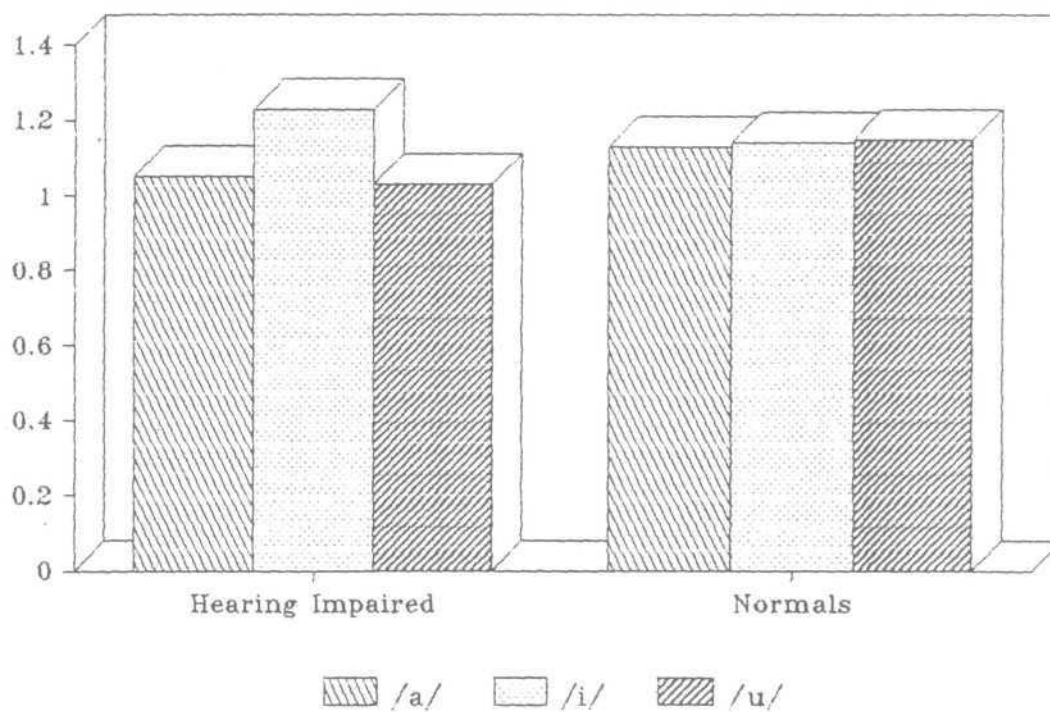

showed a mean value of 1.06; 1.08 and 1.07 with the standard deviation of 0.43; 0.35 and 0.32 as shown in Table 31.

Statistical analysis showed that there was no significant difference between the hearing impaired females and normal females for all the three vowels . Thus, the hypothesis stating that there is no significant difference in terms of "S" Ratio between the females of normal and the hearing impaired group is accepted.

A comparison of normal males and females showed statistically no significant difference. The Hearing Impaired groups also showed no significant difference for all the three vowels. Thus, the hypothesis stating that there is no significant difference in terms of "S" Ratio between males and females for both the groups is accepted.

Frequency and Amplitude Perturbation measures :

Frequency Perturbation measures :

1) Jitter ratio (JR): Jitter is the cycle to cycle variation in the period that occurs during sustained phonation at constant level.

**Table 33:** Shows mean and standard deviation (SD) for Jitter ratio in hearing impaired and normal as and female for the vowels /a/, /i/ and /u/.

Vowels	/a/		'i/		/u/	
Groups	M	SD	M	SD	M	SD
N-M	10.34	0.19	18.34	0.13	18.59	0.03
HI-M	33.31	0.30	25.32	0.30	58.61	0.19
N-F	12.39	0.05	18.49	0.04	19.28	0.02
HI-F	43.21	0.13	52.31	0.11	68.31	0.07

**Table 34:** Shows the T-value and significant difference for the Jitter Ratio for the hearing impaired and normal males and females for the vowels /a/, /i/ and /u/.

	N-M Vs N-F	N-M Vs HI-M	N-M Vs HI-F	HI-M Vs HI-F
/a/				
T-Value	.63	4.89	3.89	.89
Sig-D	–	+	+	–
/i/				
T-value	.43	4.39	3.57	.89
Sig-D	–	+	+	–
/u/				
T-Value	.83	4.39	5.93	1.34
Sig-D	–	+	+	–

Jitter Ratio in normal males indicated a mean of 10.37; 18.34 and 18.59 with a Standard deviation of 0.19; 0.14 and 0.03 for the vowels /a/, /i/ and /u/ and the hearing impaired males showed a mean of 33.31; 25.32 and 58.61 with a standard deviation of 0.30; 0.30 and 0.19 as shown in Table 33.

Statistical analysis indicated that there was a statistically significant difference between the Hearing Impaired males and normal males. Thus the hypothesis stating that there is no significant difference between the males of the normal and hearing impaired in terms of jitter ratio is rejected.

The normal females showed a mean jitter ratio of 12.39; 18.49 and 19.28 with a standard deviation of 0.05; 0.04 and 0.02 for the vowels /a/, /i/ & /u/. The hearing impaired females showed higher means of 43.21; 52.31 and 68.31 with a standard deviation of 0.059; 0.042 and 0.023. respectively as shown in Table 33 and Graphs 10, 11 and 12.

Again, there was a statistically significant difference between females of the Hearing Impaired and normal for the vowels /a/, /i/ and /u/ in terms of jitter ratio as shown in Table 34. Thus the hypothesis stating that there is no significant difference between the females of the normal and hearing impaired in terms of jitter ratio is rejected.

The study of Table 34 also shows that there was no significant difference between normal males and normal females in terms of jitter ratio. Therefore the hypothesis

stating that "there is no significant difference between normal males and females for the Jitter Ratio " has been accepted.

Table 34 also shows that there was no significant difference between males and normal females of heraring impaired group in terms of jitter ratio . Therefore the hypothesis stating that "there is no significant difference between normal males and females for the Jitter Ratio" has been accepted.

2) Directional Perturbation Factor for frequency (DPF Frequency):

It takes into account the direction and not the magnitude. It is defined as the percentage of the total number of differences in frequency for which there is a change in algebraic sign.

Table 35: Shows the mean and standard deviation (SD) for Directional Perturbation factor impaired and normal male and female for the vowels /a/, /i/ and /u/.

Vowel	/a/		/i/		/u/	
	M	SD	M	SD	M	SD
N-M	64.45	0.129	67.38	0.60	58.13	0.54
HI-M	57.58	0.53	63.64	0.79	76.92	1.17
N-F	70.16	0.70	58.13	0.60	64.50	0.45
HI-F	57.41	0.06	53.41	0.57	71.79	0.31



**Table 36:** Shows the T-value and significant difference of Directional perturbation factor Hearing Impaired and normal males and females for the vowels /a/, /i/ and /u/.

	N-M Vs N-F	N-M Vs HI-M	N-F Vs HI-F	HI-M Vs HI-F
/a/ t-value	0.43	0.49	0.34	1.25
Sig-D	-	-	-	+
/i/ t-value	0.32	0.85	0.41	0.33
Sig-D	-	-	-	-
/u/ t-value	0.43	0.75	1.35	0.41
Sig-D	-	-	-	-

Directional Perturbation Factor in normal males showed a mean of 66.29; 71.89 and 69.97 for the vowels /a/, /i/ and /u/ with a standard deviation of 0.30; 0.30 and 0.193 as shown in Table 35.

There was no significant difference between males of the two groups for vowels /a/, /i/ and /u/ in terms of Directional Perturbation Factor as shown in Table 36 and graphs 10, 11 and 12.

The normal females showed a mean of 69.58; 69.65 and 68.75 with a standard deviation of 0.063; 0.048 and 0.043. where as the hearing impaired females showed a mean Directional Perturbation Factor of 66.68; 75.99 and 71.52

respectively. Their standard deviations were 0.154; 0.123 and 0.070 as shown in Table 35.

There was again no significant difference between the hearing impaired females and normals females for the vowels /a/, /i/ and /u/ in terms of Directional Perturbation Factor as shown in Table 36 and graphs 10, 11 and 12.

Further the study of Table 36 showed that there was no significant difference between males and females of the hearing impaired group for the vowels /a/, /i/ and /u/ in terms of Directional Perturbation Factor .

No statistically significant difference between the the females and males of the normalgroup for the vowels /a/, /i/ and /u/ in terms of Directional Perturbation Factor was found as shown in Table 36.

(iii) Relative Average Perturbation (3 point) (RAP -pt):

It is defined as a comparative average of change at three different points.

**Table 37:** Shows the mean and Standard deviation of relative average perturbation factor for hearing impaired and normal males and females for the vowels /a/, /i/ and /u/.

Vowels	/a/		/i/		/u/	
Groups	M	SD	M	SD	M	SD
N-M	0.05	0.04	0.03	0.04	0.24	0.02
HI-M	0.02	0.02	0.09	0.02	0.80	0.81
N-F	0.02	0.19	.16	0.18	0.07	0.04
HI-F	0.16	0.21	.20	0.25	0.07	0.06

**Table 38:** Shows the t-value and significant difference for relative average perturbation factor in the hearing impaired and normal males and females for the vowels /a/, /i/ and /u/.

	N-M Vs N-F	N-M Vs HI-M	N-M Vs HI-F	HI-M Vs HI-F
/a/ T-Value	.54	.54	.52	.83
Sig-D	-	-	-	-
/i/ T-value	.55	.52	.53	.35
Sig-D	-	-	-	-
/u/ T-Value	.83	.54	.52	.84
Sig-D	-	-	-	-

Relative average perturbation in normals showed a mean of 0.05; 0.08 and 0.24 with a standard deviation of 0.043; 0.45 and 0.021. The Hearing impaired males showed a mean of 0.02; 0.04 and 0.80 with a standard deviation of 0,021; 0.023 and 0.81 for the vowels /a/, /i/ and /u/ as shown in Table 37 and Graphs 10, 11 and 12 respectively.

There was no significant difference between the two groups i.e. the Hearing impaired males and normal males for all the three vowels /a/, /i/ and /u/ as shown in Table 38. Therefore the hypothesis stating that there is significant difference between the normal males and the males of the hearing impaired males with reference to relative average perturbation is accepted.

The normal females showed a mean of 0.02, 0.16 and 0.07 with a Standard deviation of 0.19; 0.18 and 0.04. The Hearing impaired females showed a mean of 0.16; 0.21 and 0.25 for the vowels /a/, /i/ and /u/ with a standard deviation of 0.21, 0.25 and 0.06 as shown in Table 37 and Graphs 10,11 and 12. Further the study of Table 38 showed that there was no significance difference between the Hearing Impaired females and normals in terms of relative average perturbation for all the vowels studied. Thus the hypothesis stating that there is no significant difference between the females of the two groups has been accepted.

## PITCH PERTUB. MEASURES /a/

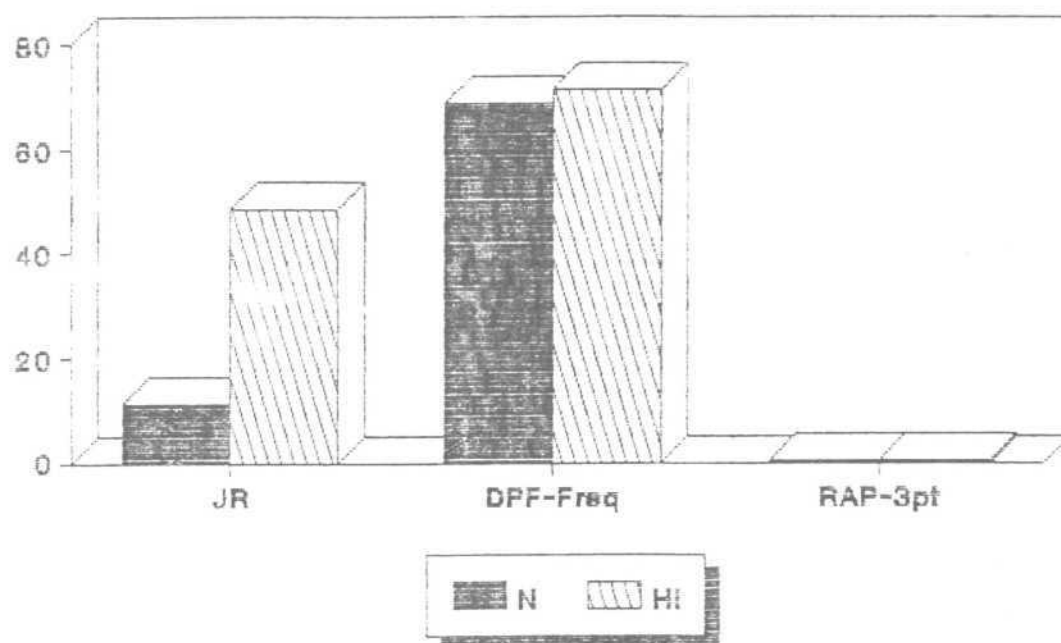

Graph-10 Shows the mean Pitch Perturbation Measures for normals (N) and hearing-impaired (HI) subjects for the vowel /a/.

## PITCH PERTUB. MEASURES /i/

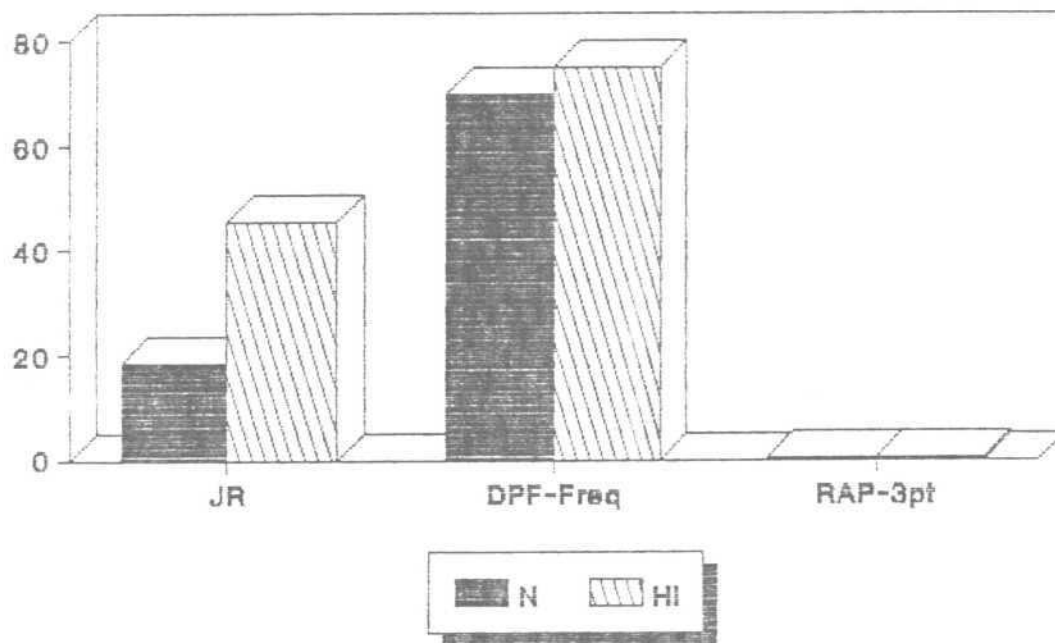

Graph-11 Shows the mean Pitch Perturbation Measures for normals (N) and hearing-impaired (HI) subjects for the vowel /i/.

## PITCH PERTUB. MEASURES /u/

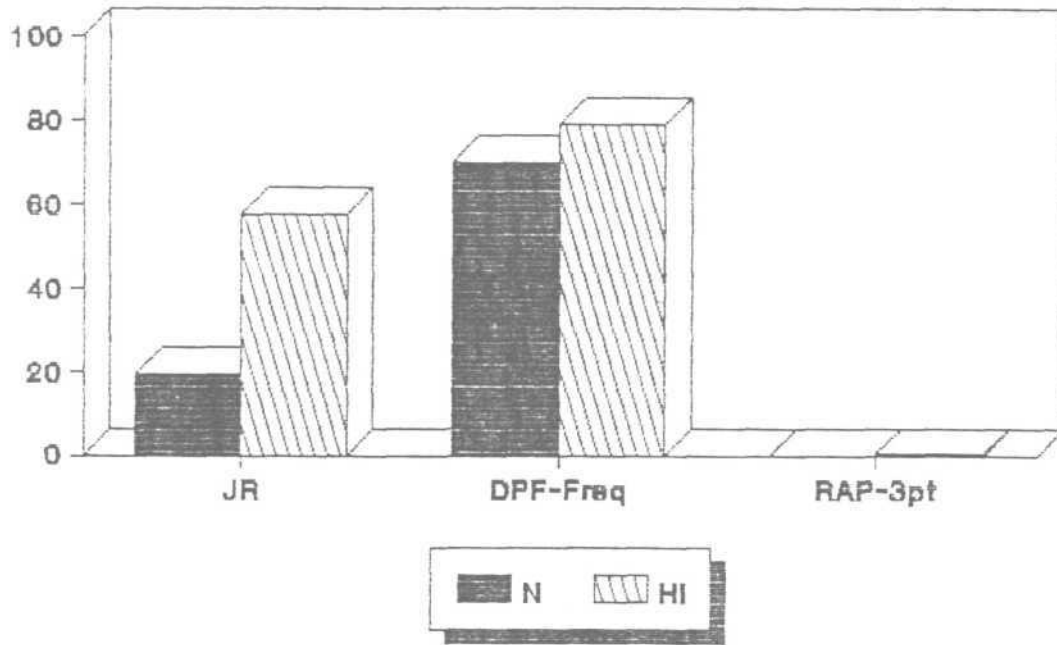

Graph-12 Shows the mean Pitch Perturbation Measures for normals (N) and hearing-impaired (HI) subjects for the vowel /u/.

The normal males and females also showed no significant difference in terms of relative average perturbation. Thus the hypothesis stating that there is no significant difference between the females and the males of the normal group has been accepted.

As it can be made out from Table-38 there was no significant difference between the Hearing Impaired females and males for the vowels /a/, /i/ and /u/ in terms of relative average perturbation. Thus the hypothesis stating that there is no significant difference between the females and the males of the hearing impaired group has been accepted.

Amplitude Perturbation measures :

i) Shimmer (dB) : It is defined as cycle to cycle variation in the amplitude that occurs during phonation at constant level.

Table 39: Shows the mean and Standard deviation of Shimmer (dB) in the hearing impaired and normal males and females for the vowels /a/, /i/ and /u/.

Vowels	/a/		/i/		/u/	
	M	SD	M	SD	M	SD
N-M	.35	0.15	.41	0.60	.42	0.54
HI-M	2.03	0.43	5.32	0.78	6.32	1.16
N-F	.34	0.70	.51	0.60	.52	0.44
HI-F	0.32	0.70	8.38	0.57	9.54	0.31



Table 40: Shows the t-value and significant difference for Shimmer (dB) in the Hearing Impaired and normal males and females for the vowels /a/, /i/ and /u/.

	N-M Vs N-F	N-M Vs HI-M	N-M Vs HI-F	HI-M Vs HI-F
/a/ T-Value Sig-D-	.34	8.53 +	9.35 +	3.85 +
/i/ T-value Sig-D-	.81	7.83 +	8.35 +	4.21 +
/u/ T-Value Sig-D-	.82	5.63 +	10.39 +	3.28 +

i) Shimmer (dB) : It is defined as cycle to cycle variation in the amplitude that occurs during phonation at constant level.

The normal males showed a mean of 0.35; 0.41 and 0.42 with a Standard Deviation of 0.15; 0.60 and 0.54 respectively. The Hearing Impaired males showed a mean of 2.03; 5.32 and 6.32 with a standard deviation of 0.43; 0.78 and 1.16 for the vowels /a/, /i/ and /u/ as shows in Table 39.

There was significant difference between the Hearing Impaired males and normal males for the vowels /a/, /i/ and /u/ as shows in Table 40 and Graphs 13, 14 and 15.

The normal females showed a mean of 0.34; 0.51 and 0.52 with a standard deviation of 0.701; 0.60 and 0.44. The Hearing Impaired females showed a mean of 0.32; 8.38 and 9.54 with a standard of 0.70; 0.57 and 0.31 for the vowels /a/, /i/ and /u/ as shows in Table 39.

There was significant difference between the Hearing Impaired females and normal females for the vowels /a/, /i/ and /u/ as shown in table 40 and Graphs 13, 14 and 15.

ii) Directional Perturbation Factor of Amplitude (DPT -amp)

Directional Perturbation Factor of Amplitude takes into account only the percentage of the total number of differences in amplitude for which there is change in algebraic sign.

Table 41: Shows the mean and standard deviation (SD) for Directional Perturbation factor impaired and normal male and female for the vowels /a/, /i/ and /u/.

Vowel	/a/		/i/		/u/	
	M	SD	M	SD	M	SD
N-M	64.45	0.129	67.38	0.60	58.13	0.54
HI-M	57.58	0.53	63.64	0.79	76.92	1.17
N-F	70.16	0.70	58.13	0.60	64.50	0.45
HI-F	57.41	0.06	53.41	0.57	71.79	0.31

Table 42: Shows the T-value and significant difference of Directional perturbation factor Hearing Impaired and normal males and females for the vowels /a/, /i/ and /u/.

	N-M Vs N-F	N-M Vs HI-M	N-F Vs HI-F	HI-M Vs HI-F
/a/ t-value	0.43	0.49	0.34	1.25
Sig-D	-	-	-	+
/i/ t-value	0.32	0.85	0.41	0.33
Sig-D	-	-	-	-
/u/ t-value	0.43	0.75	1.35	0.41
Sig-D	-	-	-	-

Normal males indicated a mean Directional Perturbation Factor of Amplitude of 64.45; 67.38 and 58.13; with an standard deviation of 0.129; 0.603 and 0.54. The Hearing Impaired males showed a mean of 57.58; 63.64 and 76.92 with a standard deviation of 0.532; 0.79 and 1.18 for the vowels /a/, /i/ and /u/ respectively as shown in Table 41 and Graphs 13, 14 and 15.

There was no significant difference between the Hearing Impaired males and normal males for the vowels /a/, /i/ and /u/ as shown in Table 42. Therefore the hypothesis stating that there is significant difference between the males of the normal and the hearing impaired groups in terms of Directional Perturbation Factor of Amplitude is accepted.

The normal females showed a mean of 70.16; 58.13 and 64.50 for the vowels /a/, /i/ and /u/ with a standard deviation of 0.60; 0.61 and 0.45. The Hearing Impaired females showed a mean of 57.41; 53.41 and 71.79 with a standard deviation of 0.06; 0.58 and 0.32 and 71.79 with a SD of 0.06; 0.58 and 0.32 for the vowels /a/, /i/ and /u/ as shown in Table 41 and Graphs 10, 11 and 12 .

There was no significant difference between the females of the two groups in terms of Directional Perturbation Factor for the vowels /a/; /i/ and /u/ as shown in Table 42. Thus the hypothesis stating that there is no significant difference between the females of the normal and the hearing impaired groups in terms of Directional Perturbation Factor of Amplitude is accepted.

Further the study of Table-42 also indicated that there was no significant difference between the females and males of the normal group in terms of Directional Perturbation Factor for the vowels /a/, /i/ and /u/ . Thus the hypothesis stating that there is no significant difference between the females and males of the normal group in terms of Directional Perturbation Factor of Amplitude is accepted.

The males and the females of the hearing impaired group showed no significant difference in terms of Directional Perturbation Factor for the vowels /a/, /i/ and /u/ as shown in Table 42. Thus the hypothesis stating that there is no significant difference between the females and the males

of the hearing impaired groups in terms of Directional Perturbation Factor of Amplitude is accepted.

i) Amplitude Perturbation Quotient (APQ):

Table 43: Shows mean and standard deviation (SD) for amplitude perturbation quotient in Hearing Impaired and Normal males and females for the vowels /a/, /i/ and /u/.

Vowel	/a/		/i/		/u/	
	M	SD	M	SD	M	SD
N-M	3.54	0.14	2.18	0.70	2.32	0.54
HI-M	7.29	0.34	6.97	0.82	6.37	1.15
N-F	2.82	0.91	3.32	0.60	2.21	0.42
HI-F	11.63	0.63	6.46	0.54	15.32	0.25

Table 44: Shows t-values and significant difference of amplitude perturbation quotient in Hearing Impaired and Normal males and females for the vowels /a/, /i/ and /u/.

	N-M Vs N-F	N-M Vs HI-M	N-F Vs HI-F	HI-M Vs HI-F
/a/				
t-value	0.34	1.32	2.46	0.43
Sig-D	-	+	+	-
/i/				
t-value	0.39	1.38	2.32	0.28
Sig-D	-	+	+	-
/u/				
t-value	0.65	2.36	2.84	1.35
Sig-D	-	+	+	-

The normal males indicated a mean Amplitude Perturbation Quotient of 3.54; 2.18 and 2.32 with standard deviations of 0.14; 0.72 and 0.54 for the vowels /a/, /i/ and /u/. The Hearing Impaired males showed higher means i.e., 7.29; 6.97 and 6.37 for /a/, /i/ and /u/ respectively. They had standard deviations of 0.34; 0.82 and 1.15 as shown in Table 43 and graphs 13, 14 and 15 .

There was significance difference between the Hearing Impaired males and normal males for all the vowels /a/, /i/ and /u/ as shown in Table 44. Thus the hypothesis stating that there is no significant difference between the males of the hearing impaired and the normal male groups in terms of Amplitude Perturbation Quotient is rejected.

The normal females showed a mean of 2.82, 3.32 and 2.21 with a standard deviation of 0.69; 0.60 and 0.42 for all the three vowels /a/, /i/ and /u/. The Hearing Impaired females showed a mean of 11.63; 6.46 and 15.32 with a SD of 0.6;; 0.54 and 0.25 for /a/, /i/ and /u/ respectively as shown in Table 43.

There was significant difference between the Hearing Impaired females and normal females for the vowels /a/, /i/ and /u/ as shown in Table 44. Thus the hypothesis stating that there is no significant difference between the females of the hearing impaired and the normal female groups in terms of Amplitude Perturbation Quotient is rejected.

Further stud/ of Table -44 showed that there was no significant difference between the Hearing Impaired females and males for the vowels /a/, /i/ and /u/ . Thus the hypothesis stating that there is no significant difference between the females and males of the hearing impaired in terms of Amplitude Perturbation Quotient is accepted.

There was no statistically significant difference between the females and males of the normal group for the vowels /a/, /i/ and /u/ as shown in Table 44 . Thus the hypothesis stating that there is no significant difference between the females and males of the normal group in terms of Amplitude Perturbation Quotient is accepted.

## AMP. PERTUB. MEASURES /a/

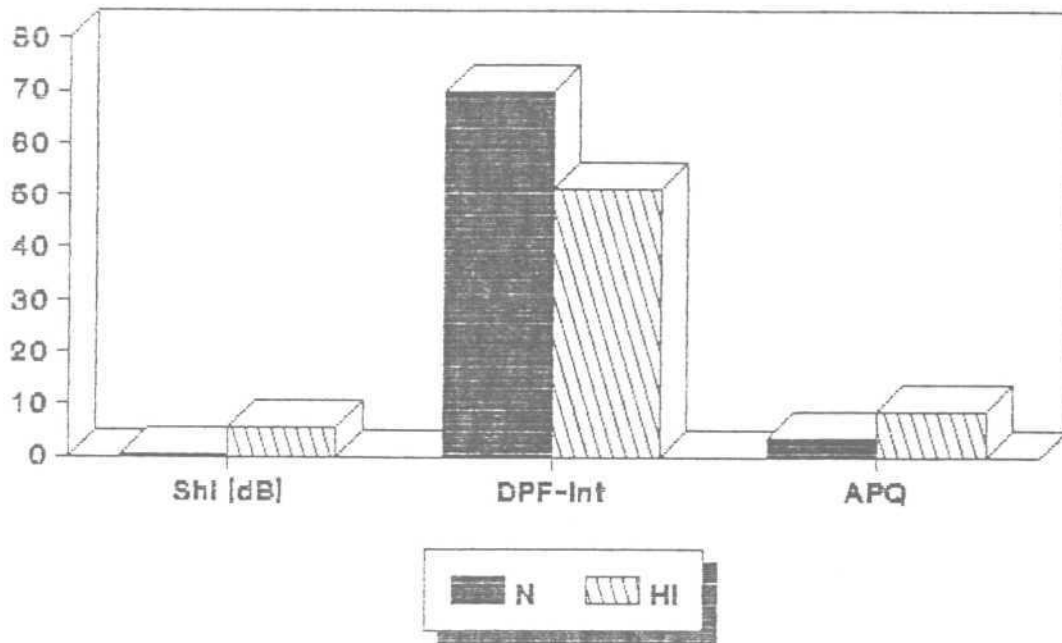

Graph-13 Shows the mean Amplitude Perturbation Measures for normals (N) and hearing-impaired (HI) subjects for the vowel /a/.



## AMP. PERTUB. MEASURES /i/

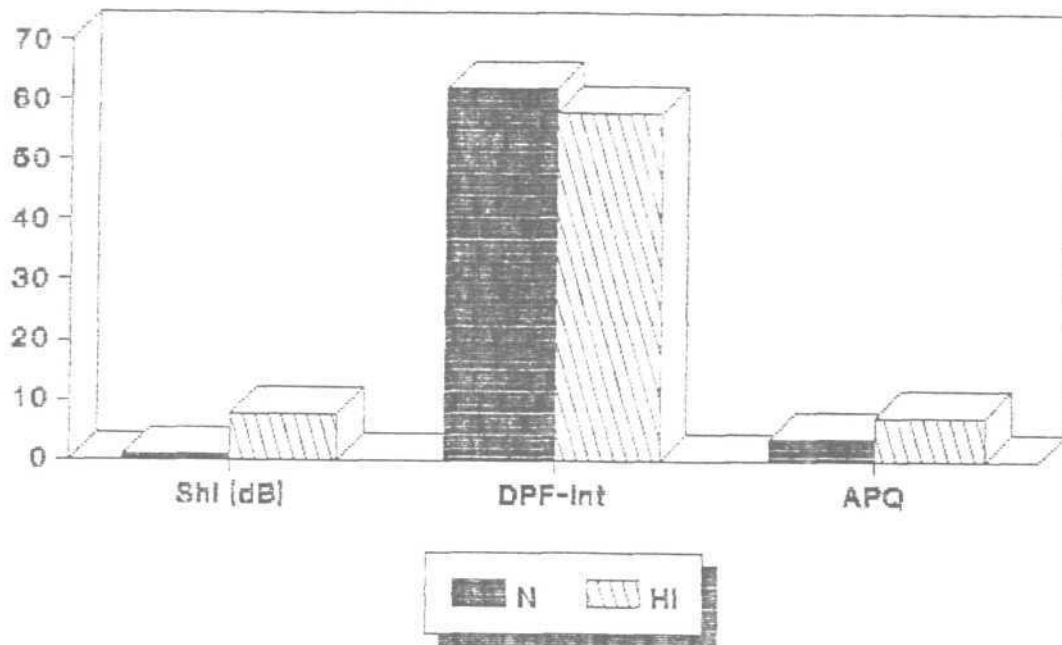

Graph-14 Shows the mean Amplitude Perturbation Measures for normals (N) and hearing-impaired (HI) subjects for the vowel /i/.

## AMP. PERTUB. MEASURES /u/

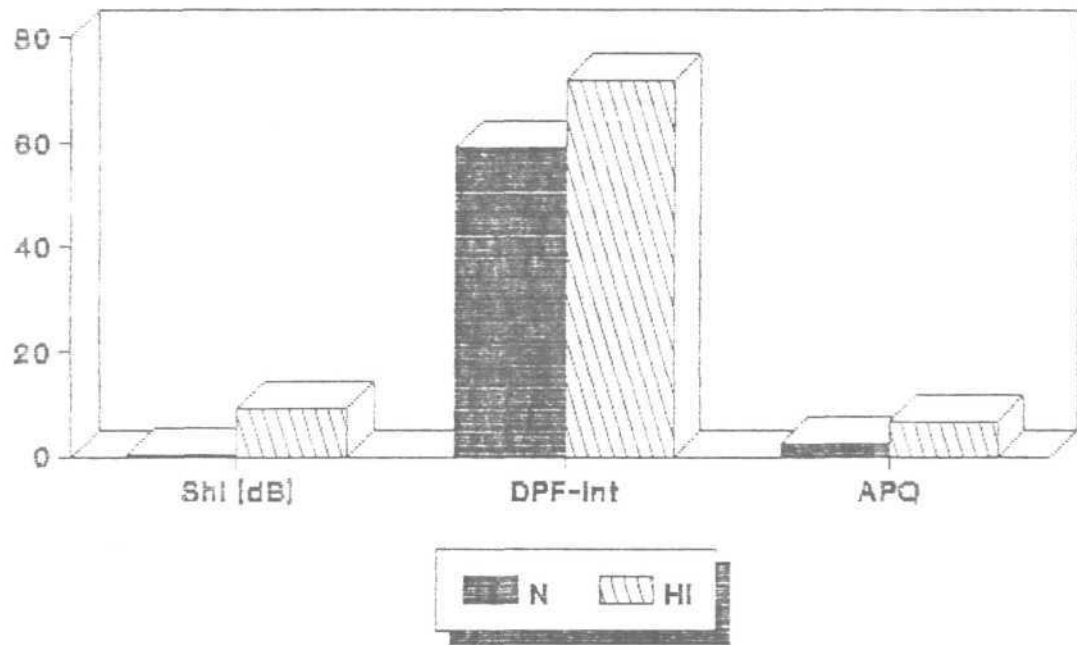

Graph-15 Shows the mean Amplitude Perturbation Measures for normals (N) and hearing-impaired (HI) subjects for the vowel /u/.

A comparison of the results of present study with that of normals of a similar age group (Rashmi, 1985;) showed that in general the hearing impaired population showed a clear cut difference away from that of the normals. It has been either increased (eg. fundamental frequency. Speaking fundamental frequency, frequency range in phonation and speech) or decreased. (eg. Rise and Fall time of phonation of vowels). In normals all the above parameters controlled by a proper coordination between the respiratory, phonatory and resonatory system and also by the finer control of laryngeal movement. Thus it can be seen that the hearing-impaired lack these controls in monitoring their voice and speech.

The measurement of these parameters would help the clinician in better understanding of the processes of speech in hearing impaired and in thus describe their speech in better terms.

So by concentrating on these parameters in therapy and by a proper feedback of these parameters by the different modes in hearing impaired can be helped in achieving voice and speech closer to the normals and thus probably, at the same time, increase the intelligibility of their speech to the 'person on the street'.

The results of the present investigation have shown the possibilities of describing the speech and voice of speech disorders, including speech and voice of hearing impaired. It is hoped that this would stimulate further investigation on similar lines.

### SUMMARY AND CONCLUSION

"Deafness, even profound deafness, does not prevent an individual from producing voice. However, the loss of hearing does affect the control of voice production, and when people listen to the speech of deaf person, a typical reaction is that the speakers voice sound "abnormal".

(MOSEN et al 1976 )

In order to investigate the effect of hearing impaired of vocal fluctuation, it is necessary to observe the vocal parameters. Therefore, the present study, was used to investigate.

Twelve subjects ( 6 males and 6 females ) of the age range of 5-9 years were selected for the study. All the subjects and HTL of 76-90 dB with no significant associated problems. Twelve normal subjects were used as the control group.

The following parameters were studied for the vowels /a/. /i/ and /u/ produced three times each by each subject of both the groups.

- 1) The frequency and intensity measures
- 2) The EGG measures
- 3) Pitch and amplitude perturbation measures.

From the statistical analysis of the data the following conclusions were drawn -

1. There was significant difference between hearing impaired and normals in the mean fundamental frequency for the vowel /a/, /i/ and /u/, normals showing lower fundamental frequency than the hearing impaired group.
2. There was a significant difference between the hearing impaired and normal males and females in the maximum fundamental frequency. The hearing impaired showed larger maximum fundamental than the normal group.
3. There was statistical difference between the hearing impaired and normal males and females for all the three vowels in terms of frequency range.
4. There was significant difference between the normal females and hearing impaired females whereas the normal males and females showed no significant difference between normal males and females for minimum fundamental frequency.
5. There was significant difference between normal females and hearing impaired females, whereas the difference between males and females of normal group as well as hearing impaired group showed there that was no significant difference between the two in terms of speed of fluctuations.

1. There was significant difference between hearing impaired and normals in the mean fundamental frequency for the vowel /a/, /i/ and /u/, normals showing lower fundamental frequency than the hearing impaired group.
2. There was a significant difference between the hearing impaired and normal males and females in the maximum fundamental frequency. The hearing impaired showed larger maximum fundamental than the normal group.
3. There was statistical difference between the hearing impaired and normal males and females for all the three vowels in terms of frequency range.
4. There was significant difference between the normal females and hearing impaired females where as the normal males and females showed no significant difference between normal males and females for minimum fundamental frequency.
5. There was significant difference between normal females and hearing impaired females, where as the difference between males and females of normal group as well as hearing impaired group showed there that was no significant difference between the two in terms of speed of fluctuations.

impaired females showed higher fluctuations than the other groups.

12. There was no significant difference between the males of the two groups. There was significant difference between the females of the two groups. The extent of fluctuation in intensity were relatively less than fluctuation in fundamental frequency.
13. There was significant difference between the normal males and hearing impaired males for the vowel /a/ only for open quotient and females of both the groups showed significant difference. The open quotient in hearing impaired was lower than in normal subjects in both males and females.
14. There was no significant difference seen between males and females of both the groups for the speed index.
15. There was no significant difference between the normals and hearing impaired males and females for the speed quotient.
16. The "S" ratio also showed no significant difference between the males and females of both the groups.
17. There was significant difference between females of the hearing impaired and normal group. The males of both groups showed no significant difference in terms of jitter ratio.

18. There was no significant difference between males and females of the two groups in terms of directional perturbation factor.
19. There was also no significant difference between the males and females of both the groups i.e., the hearing impaired and normal in terms of relative amplitude perturbation.
20. There was significant difference between the males and females of both the group for all the three vowels /a/, /i/ and /u/ in terms of shimmer.
21. There was no significant difference between the males and females of both the groups for all the three vowels in terms of directional perturbation factor of amplitude.
22. There was significant difference between normal and hearing impaired males and females for all the three vowels /a/, /i/ and /u/ in terms of amplitude perturbation quotient.

Recommendations:

1. To investigate on a larger sample of difference groups, varying degrees and types of hearing loss and different age of onsets.
2. Other parameters could be included to make it more multidimensional.
3. To observe the effect of modifying the deviant parameters on the improvement of voice quality in the hearing impaired individuals.



## BIBLIOGRAPHY

- Adams, L. (1955). Cited in Healey, E.C. (1982). Speaking fundamental frequency characteristics of stutterers and non-stutterers. *Journal of Communication Disorders*, 15, (21-29).
- Ainsworth, W.A. (1972). Duration as a cue in the recognition of synthetic vowels. *Journal of Acoustical Society of America*, 51, 648-651.
- Ainsworth, W.A. (1981). Duration as a factor in the recognition of synthetic vowels. *Journal of Phoniatrics*, 9, 333-343.
- Anderson, V. (1961). *Training the speaking voice*. Oxford University, New York.
- Angelocci, A.A. (1962). Some observations on the speech of deaf. *The Volta Review*, 64, 403-405.
- Angelocci, A.A., Kopp, G.A., and Holbrook, A. (1964). The vowel formation of deaf and normal hearing. 11-14 Year Old Boys. *Journal of Speech and Hearing Disorder*, 29, 156-170.
- Arends, N., Povel, D., Van Os, E., and Speth, L. (1990). Predicting voice quality of deaf speakers on the basis of glottal characteristics. *Journal of Speech and Hearing Research*, 33, 116-122.
- Arnold and Luschinger (1965). *Voice-speech-language, clinical communicology : Its physiology and pathology*. Wordsworth Publishing Co. Inc, California.
- Asp, C.W. (1975). *Measurement of aural speech perception and oral speech production of the hearing-impaired. Measurement procedures in speech, hearing and language*. Ed.S.Singh, Baltimore, University Park Press.
- Baer, T. (1980). *Vocal fitter - A neuromuscular explanation. Transcripts of the eighth symposium of the care of the professional voice, voice foundation*, New York, 19-22.
- Balasubramanian, T. (1981). Duration of vowels in Tamil. *Journal of Phoniatrics*, Vol.9, 151-161.

- Balaseo, S. (1953). Influence of force of articulation of consonants on vowel duration. *Journal of Acoustical Society of America*, 25, 1015-1016.
- Benda (1949). Cited in Winberg, B., and Zlatin, M. Speaking fundamental frequency characteristics of 5 and 6 year old children with Mongolism. *Journal of Speech and Hearing Research*, 13 (2), 1970, 418-425.
- Black, J.W. (1971). *Speech pathology for the deaf, speech for the deaf, speech for the deaf child : Knowledge and use.* Ed. L.E.Connor, Washington. D.C., A.G.Bell Association for Deaf, 154-169.
- Bohme, G., and Hecker,G. (1970). Gerontologische Untersuchungen Uber stimmumfang und sprechstimmlage. *Folia Phoniatica*, 22, 176-184.
- Bonne, D.R. (1966). Modification of the vowels of deaf children. *the Volta Review*, 68, 686-694.
- Boone, D.E. (1983). *The voice and voice therapy.* 3rd Edn. Prentice Hall Inc., Engle wood Cliffs, New Jersey.
- Boothroyd, A. (1970). Concept and control of fundamental frequency in the deaf An experiment using a visible display. Paper presented at the International Congress on Education of the Deaf. Stockholm, Sweden.
- Boothroyd, A., and Dackor, M. (1972). Control of voice pitch by the deaf : An experiment using a visible speech. *Audiology*, 11, 343-353.
- Borden and Harris (1980). *Speech Science Primer : Physiology, Acoustics and Perception.* Williams and Wilkins, Baltimore.
- Bowler, N.W. (1964). A fundamental frequency analysis of harsh vocal quality. *Speech Monograph*, 31, 124-134.
- Calvert, D.R. (1962). Speech sound duration and surdsonant error. *The Volta Review*, 64, 401-403.
- Chandrasekhar, K.R. (1987). *Electroglottography in dysphonics.* Unpublished Master's Dissertation submitted to the University of Mysore, Mysore.

- Chen, M. (1970). Vowel length variation as a function of the voicing of the consonant environment. *Phonetics*, 22, 129-159.
- Childres, D.G., Smith, A.M., and Moore, G.P. (1984). Relationships between electroglottography, speech and vocal cord contact. *Folia Phoniatica*, 36, 105-118.
- Colton, R.H., and Corker, H.S. (1968). Perceived in the speech of the deaf. *Journal of Speech and Hearing Research*, 11, 553-559.
- Cooper, M. (1974). Spectrographic analysis of fundamental frequency and hoarseness before and after vocal rehabilitation. *Journal of Speech and Hearing Disorders*, 39, 286-296.
- Cotton, R.H., et al. (1983). Evaluating vocal fold function. *The Journal of Otolaryngology*, 12, 291-294.
- Cotz. Cited in Rashmi, M. Acoustic aspects of the speech of children. Unpublished Master's Dissertation, submitted to the University of Mysore, Mysore.
- Cowan, J. (1936). Pitch and intensity characteristics of stage speech. *Archives Speech. Supplement 1*, 7-85.
- Curry, E.T. (1944). The pitch characteristics of the adolescent male voice. *Speech Monograph*, 7, 48-52.
- Davis, H. (1935). Cited in Stevens, S.S., and Davis, H. *Hearing its psychology and physiology*. Chapman Hall, New York, 1938.
- Dejonckere, P.H., and Lebacqz, J. (1985). Electroglottograph and vocal nodules. *Folia Phoniatica*, 37, 195-200.
- Deliyski. Cited in Rashmi, M. Acoustic aspects of the speech of Children. Unpublished Master's Dissertation submitted to the University of Mysore, Mysore.
- Elliott, L.L. and Nicrnoeller, A.F. (1970). The role of hearing in controlling voice fundamental frequency. *International Audiology*, 9, 47-52.
- Engbretson, Monsen, Vemula (1979). Some effects of deafness on the generation of voice. *Journal of Acoustical Society of America*, Vol. 66(6), 1680-1690.

- Fant, G. (1960). Acoustic sounds theory of speech production. Mouton, The Hague.
- Fletcher, S.G., Dagenais, P.A., and Critz-Crosby, P. (1991). Teaching vowels to profoundly hearing-impaired speakers using glossometry. *Journal of Speech and Hearing Research*, 34, 943-956.
- Fletcher, S.G. and Daly, D.A. (1976). Nasalance and utterance of hearing-impaired speakers. *Journal of Communication Disorders*, 9, 63-73.
- Forner, L.L., and Hixon, T.J. (1977). Respiratory kinematics in profoundly hearing-impaired speakers. *Journal of Speech and Hearing Research*, 20, 373-408.
- Fourcin, A. (1981). Laryngographic assessment of phonatory function. *ASHA Reports*, II Reprint, Chap.10, 116-128.
- Geffner, D. (1980). Feature characteristics of spontaneous speech production in young deaf children. *Journal of Communication Disorder*, 13, 443-454.
- Gilbert and Campbell (1978). Voice onset time in the speech of hearing-impaired. *Folia Phoniatica*, Vol.30 (2), 67-81.
- Gopal, N.K. (1986). Acoustic analysis of the speech in normal adults. An Unpublished Master's Dissertation submitted to the University of Mysore, Mysore.
- Gulian, Hinds, Nimmo-Smith (1986). Modifications in deaf children's vowel production : Perceptual evidence. *British Journal of Audiology*, 20 (3), 181-194.
- Gulien, E., Hinds, P., Fallside, H.R., and Brooks (1983). Vowel learning and vowel system of deaf children age and feedback related differences. *Journal of Communication Disorder*, 16, 449-469.
- Haji, Baer, Horigudu, Gould (1986). Frequency and amplitude perturbation analysis of EGG during sustained phonation. *Journal of Acoustical Society of America*, 80 (1), 58-62.
- Hanmerberg, B. et al. (1980). Perceptual and acoustic correlates of abnormal voice qualities. *Acta Otolaryngology*, 5-6, 441-451.

Heider, F., Heider, G., and Sykes, J. (1941). A study of the spontaneous vocalizations of fourteen deaf children. *Volta Review*, 43, 10-14.

Higgins, M.B., and Saxman, J.H. (1991). A comparison of selected phonatory behaviors of healthy aged and young adults. *Journal of Speech and Hearing Research*, 34, 1000-1010.

Hirano (1981). *Clinical Examination of voice. Disorders of Human Communication*. 5, Springer Verlagweim, New York.

Hirano, M., Kakita, Y., Matsushita, H., Hiki, S., and Imaizumi, S. (1977). Correlation between parameters related to vocal cord vibration and acoustical parameters in voice disorders. *Pract. Otol. Kyoto*. 70 (5), 393-403.

Holbrook, A., and Crawford, C.H. (1970). Modification of vocal frequency and intensity in the speech of the deaf. *The Volta Review*, 72, 610-611.

Hollein, H., and Copel and, R.H. (1965). Speaking fundamental frequency (Sff) characteristics of Mongoloid girls. *Journal of Speech and Hearing Disorders*, 30, 344-349.

Hollien, H., and Paul, P. (1969). A second evaluation of the speaking fundamental frequency characteristics of post adolescent girls. *Language and Speech*, 12, 119-124.

Hood, R.B., and Dixon, R.F. (1969). Physical characteristics of speech rhythm of deaf and normal hearing speakers. *Journal of Communication Disorder*, 2, 20-28.

Horii, Y. (1982). Jitter and Shimmer differences among sustained vowel phonations. *Journal of Speech and Hearing Research*, 25 (1), 12-64.

Hudgins, C.V., and Numbers, P.C. (1942). An investigation of the intelligibility of the speech of deaf and normal subjects. *Genetic Psychology Monograph*, 25, 289-392.

Itoh, M., Horii, Y., Daniloff, R.G., Binnie, C.A. (1981). Selected aerodynamic characteristics of deaf individuals during various speech and non-speech tasks. *Folia Phoniatica*, 34 (4), 191-209.

- Jones, L. (1967). Deaf voice - A description derived from a survey of the literature. *Volta Review*, 69 (8), 507-508, 539-540.
- Jones, C. (1967). Deaf voice : A description derived from a survey of the literature. *The Volta Review*, 69, 507-508.
- Kelman, S.W. (1981). Vibrating pattern of the vocal folds. *Folia Phonetica*, 33, 73-79.
- Kelman, A.M., Gordon, M.T., Morton, F.M., and Simpson, I.C. (1981). Comparison of methods of assessing vocal function. 33 (1), 51-65.
- Kent, R.D. (1976). Anatomical and muscular maturation of the speech mechanism : Evidence from acoustic studies. *Journal of Speech and Hearing Disorder*, 18, 421-447.
- Kitzing, Sonnesson (1974). A photoglotto graphical study of female vocal folds duration of phonation. *Folia Phoniatica*, 26, 138-149.
- Kitzing, P. (1982). Photo and electroglottographical recoding of the laryngeal vibratory pattern during different register. *Folia Phoniatica*, 34, 234.
- Lane, H., Perkell, J., Svirsky, M., and Webster, J. (1991). Changes in speech breathing following cochlear implant in postlingually deafened adults. *Journal of Speech and Hearing Research*, 34, 526-533.
- Lecluse, Brolaar, Verschuure (1975). The electroglottography and its relation to glottal activity. *Folia Phoniatica*, 27 (3), 215-224.
- Levitt, H. (1971). Speech production and the deaf child in speech for the deaf child : Knowledge and use. L. Connor (Ed.) Washington, D.C., A.G. Bell Association.
- Levitt, H. (1977). Analysis of the acoustic characteristics of deaf speech. NIMDB Grant Proposal No.09252 February.
- Levitt, H. (1978). The acoustics of speech and production, Auditory Management of hearing-impaired children. Eds. T.Giolas and M. Rose, Baltimore, University Park press, 44-115.

Levitt, H., Smith, C.R., and Stromberg, H. (1976). Acoustical articulatory and perceptual characteristics of the speech of the deaf children. In proceeding of the Speech of Communication Seminar. Stockholm Ed. G. Fant (Wiley, New York), 129-139.

Lieberman, P. (1963). some acoustic measures of the fundamental periodicity of normal and pathological larynges. Journal of Acoustical Society of America, 35, 344-353.

Mahshie, J.J. and Conture, E.G. (1983). Deaf speakers laryngeal behavior. Journal of Speech and Hearing Research, 26, 550-559.

Mahshie, J., and Oster, A. (1991). EGG and glottal air flow measurements for deaf and normal hearing speakers.

Maki, J.F., Conkein, J.M., Gustafson, M.S., and Whitehead, B.K.H. (1981). The speech spectrographic display : Interpretation of visuals patterns by hearing-impaired adults. Journal of Speech and Hearing Disorder, 46, 379-387.

Mallard, A.R., Ringel, H.L., and Hori, Y. (1978). Sensory contributions to control of fundamental frequency of phonation. Folia Phoniatica, 30, 199-312.

Manjula, P. (1987). Electroglottography in the hearing-impaired. A Master Dissertation submitted to the University of Mysore, Mysore.

Markides, A. (1970). The speech of deaf and partially hearing children with special reference of factors affecting intelligibility. British Journal of Communication Disorder, 126-140.

Martony, J. (1966). On the correction of voice pitch level for severely hard-of-hearing subjects. American Annals of the Deaf, 11B, 195-202.

Mashie, Conture (1983). Deaf speakers laryngeal behaviour. Journal of Speech and Hearing Research, 26, 550-559.

McGarr, H.S. (1978). Differences between experienced and in experienced listeners in understanding the speech of the deaf. Unpublished Ph.D. Thesis, City University of New York (as mentioned by Gettnee, D. 1980).

Mosen, R.B. (1979). Acoustic qualities of phonation in young hearing-impaired children. *Journal of Speech and Hearing Research*, 22, 270-288.

Mosen, R.B., Engebsetson, A.M., and Vemula, N.R. (1979). Some effects of deafness on the generation of voice. *Journal of Acoustical Society of America*, 66, 1680-1690.

Mosen, R.B. (1980). The oral speech intelligibility of hearing-impaired talkers. *Journal of Speech and Hearing Disorders*, 48, 286-296.

Nataraja, N.P., and Jagadish, A. (1984) Vowel duration and fundamental frequency. Paper presented at the ISHA Conference.

Niceerson, R.S. (1975). Characteristics of the speech of deaf persons. *Volta Review*, 77 (6), 342-362.

Rajanikanth, B.R. (1986). Acoustic analysis of the speech of the hearing-impaired. A Master's Dissertation submitted to the University of Mysore, Mysore.

Robb, M.P., and Pang-Ching, G.K. (1992). Relative timing characteristics of hearing-impaired speakers. *Journal of Acoustical Society of America*, 91, 2954-2960.

Rosh, J.B., Lomte, F., Eyraud, A., Dubreuil, L. (1990). Synchronization of glottography and laryngeal stroboscopy. *Journal of Folia Phoniatica*, 42, 289-295.

Smith et al. (1978). Vocal roughness and Jitter characteristics of vowel produced by esophageal speakers. *Journal of Speech and Hearing Research*, 240-248.

Smith, C.R. (1975). Residual hearing and speech production in deaf children. *Journal of Speech and Hearing Research*, 18 (4), 795-811.

Sridhara, R. (1986). Glottal wave forms in normals. A Master's Dissertation submitted to the University of Mysore, Mysore.

Stathopoulos, Duchan, Sonnenmiep, Bruce (1986). Intonation and pausing in deaf speech. *Folia Phoniatica*, 38 (10).



- McGarr, N.S. (1981). The effect of context on the intelligibility of hearing and deaf children's speech. *Language and speech*, 24, 255-264.
- Merkides, A. (1970). The speech of deaf and partially hearing children with special reference to factors affecting intelligibility. *British Journal of Disorder of Communication*, 5, 126-140.
- Metz, D.E., Whitehead, R.L., and Whitehead, B.H. (1984). Mechanics of vocal fold vibration and laryngeal articulatory gestures produced by hearing-impaired speakers. *Journal of Speech and Hearing Research*, 27, 62-69.
- Miller, J. (1971). Therapy for reduction of continuous phonations in the hard-of-hearing population. *Journal of Speech and Hearing Disorder*, 36, 496-498.
- Monsen, R.B. (1976 d). Second formant transitions of selected consonant vowel combination in the speech of deaf and normal hearing children. *Journal of Speech and Hearing Research*, 19, 279-289.
- Monsen (1979). Acoustic qualities of phonation in young deaf children. *Journal of Speech and Hearing Research*, 22, 270.
- Monsen, R.B., Engebretson, A.M., and Vemula, N.R. (1979). Some effects of deafness on the generation of voice. *Journal of Acoustical Society of America*, 66, 1680-1690.
- Mosen, R.B. (1976 c). Normal and reduced phonological space : The production of English vowels by deaf adolescents. *Journal of Phoniatria*, 4, 189-198.
- Mosen, R., and Later, E. (1975). Comparison of intelligibility with duration and pitch control in the speech of deaf children. *Journal of Acoustical Society of America*, 57, 569 (A).
- Mosen, R.B. (1978). Towards measuring how well hearing-impaired children speak. *Journal of Speech and Hearing Research*, 2, 197-219.
- Mosen, R.B., and Shaughnessy, D.H. (1978). Improvement in vowel articulation of deaf children. *Journal of Communication Disorder*, 11, 417-424.

Titzo, I. and Talkin, D. (1981). Stimulation and interpretation of glottographic waveforms. In Ludlow, C.L., and M.D.Hart (Eds.) Proceedings of the Conference on the assessment of vocal pathology. ASHA Report II, 48-55.

**APPENDEX-A**

---

Subjects	Age/Sex	Av.HTL (ANSI '69) at .5,1KHz & 2KHz	Type of hearing loss
1	5yrs/M	90 dB	S.N hg loss
2	6yrs/F	90 dB	S.N hg loss
3	7yrs/F	90 dB	S.N hg loss
4	6yrs/F	85 dB	Mixed hg loss
5	9yrs/M	90 dB	S.N hg loss
6	7yrs/M	85 dB	Mixed hg loss
7	9yrs/F	90 dB	S.N hg loss
8	7yrs/M	85 dB	Mixed hg loss
9	6yrs/F	90 dB	S.N hg loss
10	7yrs/F	85 dB	S.N hg loss
11	9yrs/M	85 dB	S.N hg loss
12	5yrs/M	85 dB	S.N hg loss

---