

ELECTROGLOTTOGRAPHY IN THE HEARING IMPAIRED

Register No.8507

Manjula P

A Dissertation submitted as part fulfilment for M.Sc,
(Sp. & Hg.) to the University of Mysore.

All India Institute of Speech and Hearing
Mysore - 570 006

MAY 1987

Dedicated to,

All those who are and will be
responsible
for what I will be
tomorrow.

CERTIFICATE

This is to certify that the Dissertation entitled
ELECTROGLOTTOGRAPHY IN THE HEARING IMPAIRED
is the bonafide work done in part fulfilment for Final Year
M.Sc, (Speech and Hearing) of the student with Register
Number 8507.



Dr.M.Nithya Seelan
Director
All India Institute of
Speech and Hearing,
Mysore-6.

CERTIFICATE

This is to certify that the Dissertation entitled
ELECTROGLOTTOGRAPHY IN THE HEARING IMPAIRED
has been prepared under my supervision and guidance.



N. P. Nataraja
Reader and H.O.D.

Dept. of Speech Sciences
All India Institute of
Speech and Hearing,
Mysore-6.

DECLARATION

This Dissertation entitled ELECTROGLOTTOGRAPHY IN THE HEARING IMPAIRED, is my own study done under the guidance of Mr.N.P.Nataraja, Reader and Head of the Department of Speech Sciences, All India Institute of Speech and Hearing, Mysore, and has not been submitted earlier at any University for any other Diploma or Degree.

Mysore.

Date:

Register No.8507

ACKNOWLEDGEMENT

My sincere gratitude to my teacher and guide Mr.N.P.Nataraja, Reader and H.O.D. of Speech Sciences, AIISH, Mysore, for his invaluable guidance throughout the study.

I thank Dr.M.N.Seelan, Director, AIISH, Mysore, for giving me an opportunity to carry out this study at AIISH.

My heartfelt thanks are due to -

- Mr.Venkatesh for his immense help.
- Mrs. Indira Prakash, Mr.Jagadish and Mrs. Savithri for their help.

- My friends Asha, Chandrashekar, Sreedevi, Hemalatha, Bharathi, Latha, Radhika and Sunitha for their timely help and encouragement.

- All those who took it on themselves to inform me whenever they spotted a subject appropriate for my study.

- Mummy, whose concern and moral support I cherish.

- Sudha for her patience and typing skill.

- Last but not least, all my subjects, whose problems inspired me into this study.

TABLE OF CONTENTS

<u>Chapters</u>	<u>Page No.</u>
1. INTRODUCTION	1.1-1.5
2. REVIEW OF LITERATURE	2.1-2.30
3. METHODOLOGY	3.1-3.6
4. RESULTS AND DISCUSSIONS	4.1-4.27
5. SUMMARY AND CONCLUSION	5.1-5.3
6. BIBLIOGRAPHY	
7. APPENDIX	

CHAPTER I

INTRODUCTION

"Hearing is as important to good speech as sight is to good handwriting. it is the means by which sounds are learned, articulation is directed, and inflection controlled". (West, 1947)

Hearing validates the speaker's accuracy of expression through speech. Voice being the carrier wave of speech, will be one of the aspects affected by the hearing impairment. Monsen, Engebretson and Vemula (1979) have stated that "deafness, even profound deafness, does not prevent an individual from producing voice. However, hearing impairment does affect the control of voice production".

Congenitally hearing impaired face a difficult task of learning the intricate and complex respiratory-phonatory-articulatory maneuvers. On an average, one of the five spoken words by a typical hearing impaired speaker is understood by listeners unfamiliar with their manner of speaking (Smith, 1975). Therefore, speech in the hearing impaired is not a viable- instrument for communication and can cause breakdown, frustration in daily communication, for the hearing impaired. When a hard of hearing person speaks, his voice calls attention to itself than to the content of speech. Therefore, this aspect of speech of the hearing impaired have been investigated by many (Hudgins and Numbers, 1942; Markides, 1960; Calvert, 1961; Hood, 1966; Boothroyd et.al. 1974; Nickerson et.al. 1974; Monsen, 1976; Osberger, 1978).

The voice is normally monitored by one's auditory feedback, which is affected in a hearing impaired. Sapir, McLean, and Luscher (1983) have reported that ... "the auditory feedback may have a potential role in modulating laryngeal phonatory output, reflexively mediated through brainstem".

There is a possibility of vocal abuse and vocal nodules in children with hearing loss (Seaman, 1959; Arnold, 1965). Some of the terms used to describe their voice are :

Shrill, Gruff, Monotonous, Hypernasal, Hyponasal, Breathily, Harsh, Hollow and Nonresonant.

Most of the studies on the voice of the hearing impaired, in the past years, were based on subjective evaluations where a normal listener has been used to analyse. (Hudgins and Numbers, 1942; Penn, 1958; Calvert, 1962; Martony, 1965; DiCarlo, 1968; Markides, 1970; Boothroyd et.al. 1974; Nickerson et.al. 1974; Smith, 1976 and 1986; Osberger and McGarr, 1978; Geffner, 1980; and others). Comparatively, very few objective studies have been conducted (Calvert, 1962; McClumpha, 1966; Monsen, 1974 and 1976; Gilbert, 1975; Metz, Whitehead and Mashie, 1982; and Rajanikanth, 1986) and specifically on glottal wave forms in the hearing impaired (Monsen et.al. 1979). To investigate the effect of hearing impairment on vocal functioning, it is necessary to observe the glottal wave form separately from the effects of supralaryngeal structures. It has also been found that analysis of behaviour of vocal cords would provide better understanding of the voice mechanism. Hence, the

present study aims to analyse the parameters of glottal wave forms in the hearing impaired Indian population, using an Electroglottograph (E.G.G.).

Statement of the problem:

To study the effect of the hearing impairment on the parameters of glottogram.

The study is hoped to provide some information about the effects of hearing impairment on the voice production, which inturn would help in the therapy for the hard of hearing subjects.

The hypotheses tested in the study are -

- I There is no significant difference between males and females, both in
 - a) normals and
 - b) hearing impaired groups, in the parameters measured.
- II There is no significant difference in the parameters of the glottogram between the normal and the hearing impaired groups for the vowels /a/, /i/ and /u/.

The parameters were:

- a) Open Quotient (OQ)
- b) Speed Quotient (SQ)
- c) Speed Index (SI)
- d) "S" Ratio (SR)
- e) Jitter (J)
- f) Shimmer (S)

The glottal wave forms in the hearing impaired speakers during the phonation of /a/, /i/ and /u/ using a Electroglottograph and High Resolution Signal Analyser (HRSA) were analysed.

Thirty hearing impaired subjects, fifteen males and fifteen females with a mean age of 23.27 years and 20.77 years respectively, served as subjects. Their hearing level was not less than 70dBHL in the better ear. The parameters included for the purpose of the study were:

1. Open Quotient (OQ)

OQ is the ratio between the open phase to the total vibratory cycle.

$$OQ = \frac{\text{Open phase}}{\text{Vibratory period}}$$

2. Speed Quotient (SQ):

SQ is the ratio between the opening time to the closing time in a vibratory cycle.

$$SQ = \frac{\text{Opening time}}{\text{Closing time}}$$

3. Speed Index (SI):

SI is obtained by -

$$SI = \frac{\text{Opening phase} - \text{Closing phase}}{\text{Opening phase} + \text{Closing phase}}$$

$$\text{i.e.} \quad SI = \frac{SQ - 1}{SQ + 1}$$

4. "S" Ratio (SR):

SR is given by -

$$SR = \frac{\text{Area occupied by contact phase}}{\text{Area occupied by open phase}}$$

5. Jitter (J):

Jitter is the cycle to cycle variation in the period that occurs during sustained phonation at constant level.

6. Shimmer (S):

Shimmer is the cycle to cycle variation in the amplitude that occurs during phonation at constant level.

Limitations of the study:

1. Study was carried out on 30 subjects in the age range 15-40 years and 15-29 years in males and females respectively.
2. Glottal wave forms were investigated only during phonation of vowels.
3. Only six parameters were considered.

One of the most viable theories in speech and hearing science describing the interaction between speech perception and production was given by Fairbanks (1954). Fairbanks presented his concept in the form of a model (fig.1). This model is based on operational principles rather than anatomical structures. (It contains terms like "controller unit", "motor", "generator", and "sensor", rather than brain, lungs, larynx and ear respectively). The principle of closed-cycle control was used in the model. Any self-regulating system that controls its own performance to achieve a goal, is a closed-cycle system. Another principle is that of negative feedback, which is basic to correcting the performance of an homeostatic system.

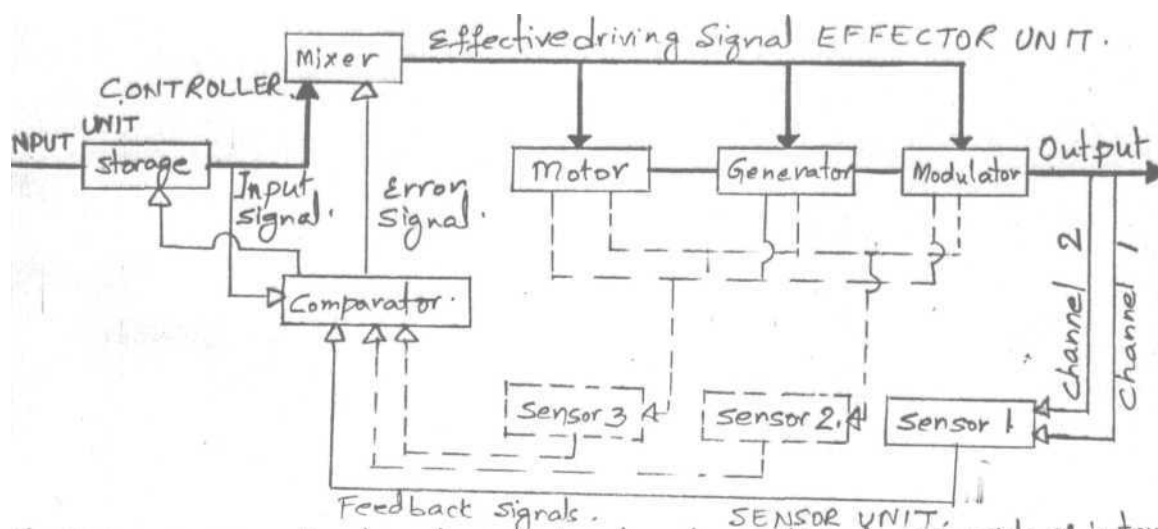

Fig 1: model of a closed cycle control system for speaking. Input consists of instructions to the effector unit for production of a sound. The sensor unit feeds back output information that is compared with original instructions to determine corrections, if any, that are needed.

In the model, the input consists of instructions to the effector unit for production of a sound. The sensor unit feeds back the output information which is compared with the original instructions to determine corrections, if any, that are needed.

*From Fairbanks, G., Systematic research in experimental phonetics

I. A theory of the speech mechanism as a servosystem. JSHD 19, 1

Manipulation of the model reveal that mistakes like substitutions, distortions, omissions, demonstrably caused by component deficiencies.

Some of the important inferences from the model are : First, to disrupt auditory, tactile, or kinesthetic feed back would be to disrupt speech output. Second, set points (articulatory targets) to guide sound production are established initially by open-cycle control when the child acquires the speech patterns of his culture. Third, once the set points that match cultural norms are stabilized, the child can guide future speech performance automatically by closed-cycle control. Conversely, if he stabilizes the set points that do not match cultural standards, he must be either unable or unwilling to discriminate and correct the difference between his defective performance and acceptable sound production.

Auditory mechanism provides feed back to the speaker only after the utterance has been made, so that one can only correct the error. However, audition is used to sharpen the speech sound target, and if speakers listen to themselves, to catch errors. (Borden and Harris, 1980)

The effect on speech and language development and maintenance is one of the most depriving effects of hearing impairment. Hearing impairment affects the voice which is the carrier wave of speech. The literature abounds with references to the voice quality of the hearing impaired.

The speech of the hearing impaired individual is not a viable instrument for communication. A naive listener may understand about one word in every five produced by a hearing impaired, while an experienced listener's (Eg. teachers of the hearing impaired) ability to understand the speech of the hearing impaired seems to be clearly superior (Mangan, 1961; Markides. 1970; Smith, 1975; and Monsen, 1978). Acquired hearing impairment will have little immediate effect on the intelligibility of the speech, but after a period of hearing impairment, certain sounds deteriorate along with voice, as one of the most important feed back instrument (i.e. hearing) is impaired.

The National Technical Institute for the Deaf, U.S.A. which carefully measured the communicative skills of each of its student upon initial enrollment, has found that among its entering students 90% could use their residual hearing to some extent but only 10% knew how to do so to their best advantage; 56% had speech that could be understood by the general public and 21% had speech that can be understood only by a trained listener, 85% were far below the average hearing college student in the ability to read or to write expressive English, and 65% in social situations in which that was the only means of receiving information. (Johnson, 1976)

The involvement of speech due to hearing impairment varies considerably according to the type, severity, age of onset of hearing impairment, and many such factors.

The speech of a person with a hearing impairment before learning to speak (pre-lingually), will present defects in voice and articulation. A person with acquired hearing impairment (post-lingually), is likely to present defects of voice, but no appreciable difficulty with articulation. If

P.T.O.

the impairment of hearing is sufficiently severe, both voice and articulatory difficulties are likely. Therefore hearing impairment can be said to have causal relationship to certain types of voice and articulation disorders (Eisenson, Kastein and Schneiderman, 1958).

Hence, there is a great need for appropriate management in terms of early identification, early intervention, improved elementary and secondary education for the hearing-impaired, increased post secondary opportunities, etc. along with the general needs like properly trained professionals, appropriate teaching techniques, and of sufficient research.

For a successful management of the hearing impaired, detailed research should not only continue but should be accelerated. The varied number of experimental limitations allows for the study of only a few factors at a time. Therefore, the effect of hearing impairment on different areas like voice, speech and language are studied separately.

The investigators have described the voice quality of the hearing impaired as monotonous, lacking accent, rhythm, poor resonance, poor carrying power and unnatural qualities (tense, breathy, harsh, throaty etc. etc.). Calvert (1962) has identified more than fifty two different adjectives to describe the quality of the voice of the hearing impaired. Voice quality deviations have been found to accompany hearing losses of 45dBHL and greater (Silverman, 1960), with the degree of abnormality of speech being greater in persons with more severe losses (Hudgins and Numbers, 1942).

Ling (1975) is of the opinion that ... "the problems related to voice as resulting from too much early emphasis on articulation skills when there has been insufficient attention paid to control of breathing and early vocalization".

Peterson (1967) has stated that ... "A child with hearing impairment may produce the same individual sounds, the quality of his word production differs from that of a child with normal hearing. Distortion of vowel-consonant transition in the formation of words and instability in fundamental frequency appear to be distinctive features of the relatively unintelligible speech. The intelligibility of speech is poor because the speech is composed of correct single element and incorrect transitions".

Engebretson, Monsen and Vemula (1979) from their study concluded that "Hearing impairment does not prevent an individual from merely causing the vocal folds to vibrate for voicing of speech. Other laryngeal functions (like protecting lungs, locking air) are like that of normal individuals in hearing impaired. Similarly individual glottal pulses are like that of normals'. In the sense, the mere generation of a glottal pulse is not hindered or changed by hearing impairment. However, speakers do not produce glottal pulses as isolated entities and they are not perceived that way either.

... Consecutive glottal pulse changes make the effect of hearing impairment apparent, i.e., the hearing impaired do not control the overall tension of the vocal folds in a manner, as evidenced by the common occurrence of period-to-period abnormalities".

Jones (1967) surveyed the literature on the voice/speech of the hearing impaired and summarized the findings as follows:

- Hudgins (1937) reported that the hearing impaired expelled more breath per unit of speech than normals.
- Rawlings (1935) indicated that the speech of the hearing impaired is produced in a breathy manner with excessive breathing movements.
- A series of studies by Voelker (1967) suggested that the durational features of the hearing impaired to be 150% slower than normally hearing. The hearing impaired had much longer pause intervals between phonation, on an average. They took time almost four times greater than normals to say a sentence.
- Mason and Bright (1937) have reported an overall slowness, the rate of the hearing impaired speaker varied greatly within a sentence, whereas the rate of a normally hearing speaker was quite constant.
- Forner and Hixon (1976), Whitehead (1982) have observed two respiratory problems in the hearing impaired. The are:

"1. They initiate phonation at too low level of vital capacity and produce a reduced number of syllables per breath.

2. They mismanage the volume of air by inappropriate valving at the laryngeal level, i.e., 100 cc/syllable, whereas for normals it is 20-40 cc/syllable".

- Scuri (1935) and DiCarlo (1964) reported poor rhythm resulting from inadequate breath control during speech production.
- Angelocci (1964) has concluded that hearing impaired do not have clearly defined vowel target areas in physiologic terms. The hearing impaired speaker apparently achieves vowel differentiation by excessive laryngeal differentiation with only minimal articulatory variations.

Voice onset time (VOT) in hearing impaired subjects has also been submitted for observation by Campbell and Gilbert (1978)... "Voice onset time is an acoustic cue which may be used to evaluate the coordination between the vocal fold activity and articulatory movements. As a group, hearing impaired speakers exhibited longer voice onset time for voiceless stops than their voiced cognates in both pre-and post- vocalic contexts. VOT for hearing impaired were shorter than for normal hearing, which may be due to reduced intraoral pressure during the production of stop consonants. Reduced intraoral pressure would increase the transglottal pressure differential which inturn would decrease the lag in vocal fold vibration activity or the shorter voice onset time may be due to lack of auditory feed back resulting in early onset of laryngeal activity after the release of stop consonant".

Horii (1982) opined that the pre- and post- phonatory abnormal behaviours of the hearing impaired suggested a lack of fine coordination and timing between respiratory and phonatory systems, while the unstable air flow pattern seems to be indicative of spasmodic muscular movements.

Studies on pitch and intonation in the hearing impaired have also been carried out. In normals, fundamental frequency or pitch varies within individuals and between individuals. Average fundamental frequency decreases with age until adulthood for both males and females (from 275-300Hz to about 200-225Hz in females; from 275-300Hz to about 100-150Hz in males). With advancing age, fundamental frequency increases by about 30 to 40Hz ... (Hollien & Shipp, 1972; and Mysak, 1959)

According to Fairbanks (1940), the fundamental frequency in normal speech varied over a range of 1-1 1/2 octaves.

Hearing impaired are apt to have a relatively high average pitch leading to vocal strain or to speak in falsetto voice (Angelocci, Kopp, and Holbrook, 1964; Boone, 1966; and Martony, 1968). The problem was more in teenagers particularly in adolescent boys (Boone, 1966). Also the average fundamental frequency of different speakers spans over a wider range.

Fundamental frequency when measured at the initiation and termination and at the high and low points of each cry in the hearing impaired and normal children, showed a consistently higher fundamental frequency in cries of hearing impaired at all age levels (from 12 months to 4 years), average difference being 120Hz ... (Jones, 1967)

Meckfessel (1964) and Thornton (1964) have reported that the speaking fundamental frequency in post-pubescent hearing impaired males that were higher than those for normally hearing. Ermovick (196b) and Gruemould (1966) have also reported similar results.

Rajanikanth (1986) reported a fundamental frequency of the vowel /a/ in 10-15 year age group to be closer to normal range; whereas for /i/ and /u/, it was much higher than normal hearing subjects. The 15-20 year age group showed a significantly higher fundamental frequency than normal hearing. He also reported frequent pitch breaks towards lower frequencies and sometimes higher, resulting in a wide frequency range. Thus showing an inability to produce the vowel with steady pitch.

In speaking, Rajanikanth (1986) reported that, the fundamental frequency differed between the two age groups in males. In contrast to males, the hearing impaired females showed a larger mean value than normals and also a wide individual variations. This was attributed to the lack of auditory feed back and/or to higher fundamental frequency than normals.

Average fundamental frequency of speech in the hearing impaired increases with the difficulty of the utterance. Production of high pitch requires increased vocal effort (such as increased tension in cricothyroid muscle and increased subglottal air pressure). Willemain and Lee (1971)

hypothesized that the hearing impaired speakers generate high pitched tones as a way of providing kinesthetic cues concerning the onset and progression of voicing. Some unusual pitch variations in the speech of hearing impaired may result from attempts by the speaker to increase the amount of proprioceptive feed back that he receives from the activity of speech organs.

The hearing impaired are unable to control the laryngeal musculature during speech production. According to Isshizaka and Isshiki (1976), variability in phonation is related in part to a tension imbalance between right and left vocal folds, or to inappropriate laryngeal structure positioning ('postural' error in speech production). This leads to perturbations of the vocal fold vibratory cycles and/or spatially and temporally inappropriate vocal fold abductory actions associated with certain segmental devoicing gesture.

Mashie (1984) has reported a unique and abnormally wide glottal opening interfering with temporal scheduling between laryngeal and oral events associated with voiceless stops.

Mashie (1984) also observed that the abductory-adductory gestures appeared to be discontinuous in nature * which may be due to certain inappropriately abstracted suggestions made during speech training of the hearing impaired.

Pitch variations in subjects with hearing loss has been

found to be less when compared to normal hearing, i.e. flat, monotone speech has been observed (Calvert, 1962; Martony, 1968). Sorenson (1974) reported particularly inappropriate pitch breaks or insufficient pitch changes at the end of the sentences. A terminal pitch rise may be more difficult for a hearing impaired to produce than a terminal fall (Pronovost et.al. 1968). Hearing impaired subjects who tend to produce such syllable with equal duration may also generate a similar pitch contour on each syllable. Such speakers fail to indicate variations in stress either by changing the syllable duration or by modifying pitch contours on the syllables.

McGarr and Osberger (1978) evaluated the pitch deviancy of the hearing impaired on a five-point rating scale of perceptual judgement. Results showed that a large number of children received pitch ratings that were either appropriate for their age and sex or differed only slightly from optimal level. Some children showed pitch break or large fluctuations in pitch.

i

t

Pronovost (1968) reported that the hearing impaired tend to increase the vocal effort while trying to increase the pitch.

Fairbanks et.al. (1954) have found that the hearing impaired children produce the vowels (i,I,u) on a higher fundamental frequency than the other vowels of English. In normals, high vowels are produced on a higher fundamental frequency than low vowels, resulting in an inverse

relationship between fundamental frequency and frequency location of first formant of the vowel. Fundamental frequency in hearing impaired for all vowels was higher (Angelocci, 1964) measures of vowel amplitude was also higher in hearing impaired than normals. But range of frequency and amplitude values was greater for normals than for hearing impaired in the formants.

Studies on the loudness of the voice in the hearing impaired have also been conducted. The voice of the hearing impaired is either too loud, or too soft, or with erratic changes in loudness. The way in which the loudness of a speaker's voice is affected by hearing loss depends on the type of hearing impairment. Miller (1968), Berry and Eisenson (1947) have stated that the person with sensorineural hearing loss can be differentiated from a person with conductive hearing loss on the basis of voice. The latter will have a voice which is loud enough for him to hear himself. In this group, regardless of the age of onset of hearing impairment, loudness of voice will be inadequate and the voice also lacks the variety in pitch. The one with sensorineural hearing loss uses a loud voice in order to hear himself.

Several workers have studied the quality of voice in the hearing impaired. Hearing impaired have a distinctive voice quality according to Bodycomb (1946), Boone (1966), Calvert (1962) and many others. However, the exact definition of the term voice quality itself is not clear. Calvert (1962) has listed more than fifty two different adjectives (flat, breathy, nasal, throaty ...) to describe the quality of voice in hearing impaired. Objectively, there is no general characteristic that best typifies the speech of the hearing impaired (Benson, 1957; Smith and Hutchinson, 1976).

Peterson (1946) considered voice quality to be relatively unimportant for speech intelligibility. On the other hand, Adams (1914) pointed that ... "it might have little effect on intelligibility, but plays a very important role in determining whether what a hearing impaired individual is saying will in fact be understood by an unfamiliar listener".

Calvert (1961) reported that the teachers of the hearing impaired subjects could reliably differentiate the voices of the profoundly hearing impaired from normal speakers, provided the speech sample had articulatory movement, such as a diphthong or a CVC syllable. Further, Calvert (1961) has opined that this differentiation is related to articulatory movement over time rather than to .

voice quality per se. Calvert (1961) also noted that the voice of the hearing impaired was identified not only on the basis of relative intensity of the fundamental and the harmonic frequencies, but also by the dynamic factors of speech such as transition gestures, that change one articulatory position into another.

Miller (1968) has speculated that - "the type of hearing loss to be a causative factor for nasalization problems in some i.e., hyponasality may be prevalent among conductive loss individuals, because, the nasal sounds may appear excessively loud to the former, due to bone conduction hearing. Individuals with sensorineural hearing loss, on the other hand, may welcome additional cues provided by nasal resonance and therefore tend to nasalize sounds that should not be nasalized".

Nickerson (1975) elaborated on the above speculation, that ... "the nasality problem is a voice quality problem, it can also give rise to articulatory problem in sounds like m,n,y which may be substituted by b,d,g or vice versa. Timing of velar movement is also important in nasalization".

Breathing can be heard in the voice of the hearing impaired, which may be due to inappropriate positioning of vocal cords and poor control of breathing during speech, i.e., too large a glottal opening. because of failure to close the vocal folds properly, may result in a large expenditure of air and thus produce a voice of poor quality (Hudgins, 1937).

According to Ling (1876) ... "breathy voice quality occurs when there is relatively little tension on the vocal cords, which therefore open and close mainly in response to aerodynamic flow (The Bernoulli effect). In this condition, the glottal pulses which set the supraglottal cavities to resonances have a weak, triangular wave form, the resulting voice spectrum has been found to be weak in upper partials. When more muscle tension is exerted, the vocal cords are less readily parted by subglottal pressure and more readily close in synchrony with Bernoulli force. The glottis in this latter condition opens for less than half of the vibratory cycle (the extent depends on the degree of muscle force), and the resulting glottal pulses, having a sharper onset-offset time, resulting in a voice with strong high frequency components. Spectrum of a breathy voice may have a slope of 16dB/octave, the spectrum of a stronger voice may have a slope of less than 16dB/octave. In the latter, the upper formants of the vowels will be considerably more audible than when the voice is breathy".

Harmonic distribution in the hearing impaired voice would not only show the phonatory behaviour but also the contribution of supraglottal resonators to the voice.

Ling (1976) further has stated that ... "tension of the pharyngeal walls accounts for a considerable proportion of vocal resonance problems that among hearing impaired. Pharyngeal tension tends to inhibit modification of vocal

pitch because the tension in pharyngeal structures usually extends to the larynx. It also modifies the shape of the cavity behind the tongue and hence changes the intensity and frequency of the vowel formants. Such tension may be induced through speech exercises involving exertion or may occur of learning to modify vocal pitch, through feeling the larynx

"... Further, the strain imposed during the act of voicing leads to inflammation and/or structural changes in the larynx ... (as in hard glottal attack, tension of vocal folds, etc.) which in turn led to vocal abuse.

.... Children with no or minimal residual hearing use falsetto voice, which can be prevented easily by making use of low frequency audition, or stretching the head backwards".

Problems on attributes of voice, though dealt independently are not independent. (Eg; pitch, volume and timing are intimately interdependent as determiners of stress) Most of the hearing impaired individuals must be taught to acquire this interdependent skill. Lass (1982) stated that "within the last two decades, advances have been made in studying the speech of the hearing impaired, which is largely due to development of sophisticated processing and analysing techniques in speech science, electrical engineering, computer science ... which have increased the knowledge of normal speech production. In turn these advances have been applied to analysis of the speech of the hearing impaired as well as to the development of clinical assessment and training procedures".

According to Fourcin and Abberton (1972) visual display helps in training the hearing impaired. They opine that, the instantaneous display of the systematically changing fundamental frequency patterns of speech forms a basis for training intonation and rhythm which are crucial factors of speech for conveying grammatical, semantic information and emotional attitudes.

The vocal fold vibration is observed and measured through various techniques like endoscopy, stroboscopy, inverse filtering etc., Clinically laryngeal wave forms or laryngogram (Lx) can be recorded on a simple equipment known as Electroglottograph or Electrolaryngograph with a display unit, and it is quite unaffected by acoustic noise. (Fourcin, 1974)

Electroglottography is a technique in which the transverse electrical impedance varies with opening and closing of the glottis, and results in variation of the electrical current in phase with the vibratory phases of the vocal fold, resulting in glottogram (Lx). The glottogram or laryngogram provides information, during voicing, regarding frequency of excitation, perturbation in vibration, etc.

Characteristics of Lx:

Vocal fold vibration in normal voice production is highly complex. Lx is a function of the electrical impedance across the thyroid cartilage of the speaker.

Different investigators give different descriptions of Lx. Hirano (1981), Moore and Thompson (1985), divided the vibratory cycle into opening, closing and closed phase. The interpretation of Lx was confirmed by Fourcin (1974), who correlated the different phases of the Lx with the glottal area obtained simultaneously on stroboscopy photography.

There are three layers in the vocal cords - body, cover and mucus. In normal voice, from the beginning of the open phase to its end, the cover of the vocal fold is deformed by a wave-like motion which travels from the lower to the upper surface. The end of the open phase is characterized by contact between the extrude covers at the lower edges of the glottis. The beginning of separation phase is also initiated at the lower surfaces and the cover surfaces more gradually pull apart as the area of contact is diminished. Complete period is then recommended by the onset of closure as before.

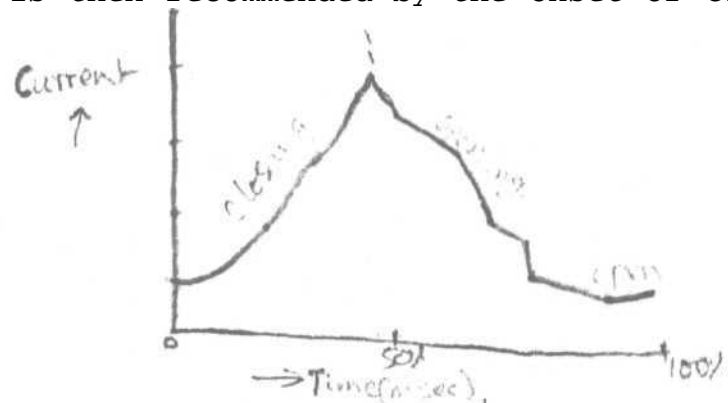

Fig 2: Curve of glottal waveform as a function of time

Relative duration of the phases is variable, depending on the circumstances of phonation. Usually the opening phase (OP) is 50% of the vibratory cycle, closing phase (CP) is 37% and the closed phase (C) is 13% at conversation pitch and intensity.

Closing phase is the sharp upward curve in the Lx wave form. Maximum vocal fold contact is when the Lx is at its peak. The slower separation of the vocal folds is shown by the shallow curve leading to the flat trough in Lx which is related to opening phase. This opening phase is larger than closing phase with respect to the time in milliseconds. This is probably because, during closing, along with the Bernoulli's force, elastic recoil of the vocal folds also play a role. This additional force reduces the closing phase duration.

The absolute magnitude of the signal (mv) is not taken in the measurement because, there are major fluctuations due to bypassing effects through subcutaneous fat and other neck tissues. Moreover, a large variability is observed between individuals. (Lecluse, 1977)

The time at which conductance is maximal is always easily identified and therefore, considered as a valuable reference point.

Artifacts that may occur in the use of E.G.G. are:

- Variation of impedance between the electrodes and the skin, that do not depend on the vocal fold movements are also included.
- Vertical displacement of the larynx in relation to electrodes.
- Condition of cervical structures other than glottis.

Timcke, Von Leden and Moore (1958), expressed the relative durations of the phases of vibratory cycle in terms of quotients. Since then various quotients and indices have been derived using the measurements of duration of different phases of the vibratory cycle in order to study the glottal waveform.

1. Open Quotient: (OQ)

OQ is defined as the ratio of the open phase to the total period of vibration, i.e.,

$$OQ = \frac{\text{Open phase}}{\text{Total duration of the cycle}}$$

There is a relationship between OQ and the fundamental frequency of vocal fold vibrations. OQ has been found to increase with increases in fundamental frequency. (Timcke, 1957)

Timcke (1957 and 1960) observed an increase in OQ with falling intensity and decrease in OQ with rising intensity. But Luschinger (1956) stated that OQ was practically independent of sound intensity. (i.e. OQ was 0.66 and 0.66 at two pitch levels of 327 and 325Hz at 65 phons. And 0.66 and 0.62 for these pitch levels at 80 phons).

Timcke further states that OQ was larger with open phase being larger. The value of OQ was 1.0 when there was no complete glottal closure.

It has been demonstrated mathematically (Flanagan, 1958) and experimentally (Van den Berg, Zantema and Doorenbal, 1957; Timcke, Von Leden, and Moore, 1950) that the vocal intensity increases, along with efficiency of the glottal generator, as the OQ decreases, i.e. as the fraction of the glottal cycle during which the glottis is open, becomes smaller. A small OQ describes a condition in which strong, short glottal pulses excite the vocal tract to resonate high harmonics; the sharper the puff, the richer the glottal wave in the high frequency components or high harmonics characterize acoustically powerful efficient vocal tones.

Timcke et.al. (1958) illustrated the relationships between OQ and the period of vibration with respect to vocal intensity.

In the above figure. the opening phase was stable with loudness change. Loudness was a function of closing phase, according to Timcke et.al. (1958).

Isshiki (1966) has found that " ... increase in intensity brings about increase in closed phase only at low frequency. At high frequency, muscles of exhalation help in increasing the intensity.

2. Speed Quotient (SQ) or Velocity Quotient (VQ):

The time relationships between the opening and closing phase of each vibrator is speed quotient, according to Lusching (1965). The SQ was proportional to vocal intensity, but was not influenced by the changes in pitch,

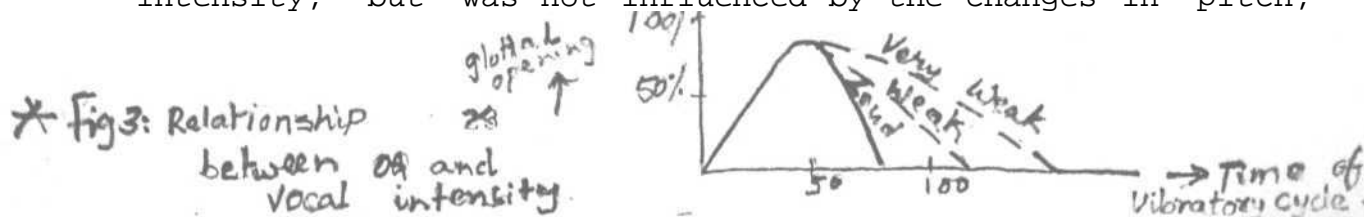

register, vocal type, or sex. During phonation, the vocal folds close faster than when they open. As the loudness increased, the lateral displacement of the vocal folds also increased, as they were blown more vigorously apart (Timcke et.al. 1958). For trained voices, less lateral displacement and a longer period of closure than for untrained, was reported by Fletcher (1954). The value of SQ given by Timcke et.al. (1958) was 1.17.

3. Speed Index (SI):

SI is derived from SQ (Hirano et.al. 1981). The value of SI varies from -1 to +1. It is a relative ratio where positive values indicate more of opening time and negative value means more of closing time of the vibratory cycle; a zero value indicates equal timing. SI seems to have some advantages over SQ for

- SI ranges from -1 to +1 whereas SQ ranges over larger values.
- When two wave forms have similar shape, but one is the reverse of the other in terms of phase, SI takes equal absolute value with reverse signs. But SQ takes two different values, whose product is one.
- One can visualize the wave form from SI values more easily than SQ values.
- SI has a similar relationship with the spectral characteristics of the wave form than SQ (Hirano et.al. 1981).

4. "S" Ratio (SR):

SR is the ratio of contact phase to open phase. In normals, it is around 0.657, whereas it is 0.608 in dysphonics.

6. Jitter and Shimmer (J&S):

Jitter and Shimmer are physical correlates of rough or hoarse voice (according to Moore and Thompson, 1965; Michel, 1966; Coleman and Wehdahl, 1967). A method of quantifying normal and abnormal voice is to measure the difference between the period of each successive cycle. This is Jitter, which is expressed either in milliseconds or in percentage. Jitter is the extent of rapid abrupt change in adjacent periods of the fundamental frequency wave (Iwata and Von Leden, 1970). Horigudu, Haji, Baer and Gould (1986) have speculated a relation between jitter analysis of E.G.G. wave forms and the degree of hoarseness (Spearman's rank correlation coefficient, $r_s = 0.73$, $p < 0.0005$).

Amplitude perturbation or amplitude variation from cycle to cycle is shimmer, expressed in dB. Horigudu, Haji, Baer and Gould (1986) found that shimmer was more sensitive to laryngeal pathology than jitter. Both jitter and shimmer differentiated extremely and moderately hoarse voices, but only shimmer could differentiate between moderately and slightly hoarse voice.

Jitter and Shimmer have been found to be useful in differentiating normal from abnormal voice by Koike, 1969, 1973; Michel et.al. 1973; Horii, 1978, 1979 and others. In fact, Liberman (1963), Montgomery et.al. (1970) have reported early detection of laryngeal pathology using shimmer and/or jitter.

At comfortable level, average jitter is 1% or less in phonation. Different values of jitter and shimmer as reported by different investigators.

Jitter: 0.6% (Jakob, 1968) and
0.5% (Horii, 1979).

Shimmer: 0.1dB (Koike, 1969; Gould & Kitajima, 1976) &
0.5dB (Horii, 1982).

Jitter and shimmer differences have been shown to exist among different vowels by Horii (1982). Normative data from Wilcox and Horii (1960) have shown that /u/ was associated with significantly smaller jitter (0.55%) than /a/ and /i/ for which the value is 0.68% and 0.69% respectively.

Johnson and Michel (1969) have reported a higher jitter for high vowels than for low vowels. It has also been reported that when subjects were asked to phonate at a special intensity and/or as long as possible, jitter and shimmer values increased.

Horii (1982) observed that vocal fry was characterized by greater jitter and shimmer values than in modal phonation i.e. 2.5 Vs 0.9% of jitter, 1.15 Vs 0.48dB of shimmer respectively.

Monsen, Engebretson and Vemula (1979) have found the rate of jitter to be higher for hearing impaired. For normals, jitter rate tended to be close to the maximum period-to-period change, while for hearing impaired, maximum period-to-period change was greater than average jitter.

Monsen et.al. (1979) further observed that in most of the hearing impaired, the average shimmer was between 0.02 to 0.06dB (which is also the normal range) but a few had double this amount. The large amounts of jitter and shimmer constituted an incipient form of diplophonia, or atleast were related to diplophonia in cause.

There are divergent results pointing to the complexity of the relationship among a large number of variables that affect vocal production. Studies are needed to determine the variables and their interaction in voice production. (Perkins, 1982)

Fourcin (1974) has reported E.G.G. in different dysphonias.

In breathy voice, the open phase was longer, with long plateau between the end of separation and beginning of contact.

In creaky voice, low irregular pitch with sharply defined vocal tract resonances, closed phase was unusually larger; double vibration pattern (synchopated pattern) was also reported by Moore and Von Leden (1958).

In recurrent laryngeal nerve paralysis, high and low frequency irregularities were noted.

In laryngeal carcinoma, multiple peaks were observed.

Limited frequency range was observed in vocal polyp, and also in hearing impaired.

Speech of a congenitally hearing impaired was markedly irregular (Engebretson et.al. 1979).

Fourcin and Abberton (1972) have opined that speech therapy with interactive visual display of the vocal fold vibration wave forms improved speech, widened the range of fundamental frequency and reduced the scatter.

Fourcin (1979) made simultaneous recordings of E.G.G. and air flow velocity curves for different modes of phonation. He found that the fundamental frequency and the vocal fold vibration could be determined quite accurately using E.G.G. wave forms.

The nature of sound generated by vibration of vocal folds can be specified in terms of acoustic and psychoacoustic terms. These (fundamental frequency, spectrum, time related variables) are useful in drawing a voice profile as they provide objective and quantitative data.

Norms of acoustic parameters have been given, for Indian population, by Kushalraj (1984), Rashmi (1985), Vanaja (1986) and Sridhara (1986). Sridhara has given normative data for the parameters measured on E.G.G. A study of the acoustic parameters in the hearing impaired was done by Rajanikanth (1986). Such information is useful in providing therapy goal and to check the effectiveness of a technique.

The normative values given by Sridhara (1986) using E.G.G. for the vowels /a/, /i/, and /u/ are :

OQ was found to be 0.52 in males and females; SQ was 1.84 in males and 2.17 in females (the difference between males and females being significant at 0.001 level), SI was 0.29 in males and 0.36 in females (the difference between males and females being significant at 0.05 level), "S" Ratio was 1.12 in both males and females, jitter value was 0.060

msec. in males and 0.046 msec in females (difference significant at 0.05 level), and, the shimmer value was 0.180dB in males and 0.315dB in females (difference significant at 0.05 level).

Rajanikanth (1986) studied the acoustic parameters in the hearing impaired and found that the hearing impaired used a higher fundamental frequency than normals in phonation (/a/, /i/ and /u/) and in speaking. He also reported a wide variation in frequency range and intensity range between hearing impaired and normals, the range being more in the former in both speaking and phonation. Further, the hearing impaired and the normals differed significantly in terms of rise time, fall time and maximum phonation duration. The difference between hearing impaired and normals reduced (in rise time, fall time and maximum phonation duration), as the age increased. This study is the only study on the acoustic parameters of the hearing impaired in the Indian population.

The Review of Literature so far indicates that most of the studies are on subjective evaluations (i.e. listener as an analyser). (Hudgins and Numbers, 1942; Penn, 1958; Calvert, 1962; Martony, 1965; Nober, 1967; Markides, 1970; Smith, 1975; McGarr, 1978; Geffner, 1980).

Comparatively, there are few objective data (Calvert, 1962; McClumpha, 1966; Monsen, 1974, 1976; Gilbert, 197b; Rajanikanth, 1986) and specifically on glottal wave forms in the hearing impaired (Engebretson, Monsen and Vemula, 1979). Hence the present study is devoted to analyze the vocal fold vibration in the hearing impaired with the use of electrogiottography technique, in Indian population. The results thus obtained would provide information regarding the voice production in the hearing impaired and it is hoped that this would help in the therapy of voice problems in the hearing impaired. It is also hoped to stimulate further investigations on voice, speech and language of the hearing impaired.

CHAPTER III

METHODOLOGY

The purpose of the present study was to analyze the vocal fold movement during phonation in hearing impaired individuals, using electroglottography. Parameters selected for the purpose were:

1. Open Quotient (OQ)
2. Speed Quotient (SQ)
3. Speed Index (SI)
4. "S" Ratio (SR)
5. Jitter (J)
6. Shimmer (S)

Test Environment:

Speech Sciences Lab, All India Institute of Speech and Hearing, Mysore.

Subjects:

Hearing impaired subjects with the following details served as subjects for the study.

Sex	Number	Age (yrs)	
		Mean	Range
Male	15	23 .27	15-40
Female	15	20 .77	15-29

Table-1: Details of hearing impaired subjects tested.

Hearing threshold in each subject was not less than 70dBHL in the better ear, and the onset of the hearing loss being pre-lingual in age. Except for hearing loss, there was no significant ENT problem, and no obvious mental retardation associated, at the time of testing. Speech perception and production abilities were not regarded for the purpose of the study.

Equipment

used:

Electrolaryngograph (Kay Elemetrics Corporation)

High Resolution Signal Analyzer (B & K Type 2033)

The signal from the Electrolaryngograph was fed to HRSA, which permitted the measurement of each phase of vibration and its display.



Fig.3 : Block diagram of the equipment used.

Details of the E.G.G./ELG is presented in Appendix.

Procedure:

The subject was made to sit comfortably in front of the equipment. The electrodes were placed over the neck on either side of the thyroid cartilage. The electrodes were held in place by a neck band. The experimenter located the cartilage before placing the electrodes. The position of the electrodes was adjusted to obtain a clear wave form (Lx) on the screen of HRSA.

Speech Sample:

Phonation of vowels /a/, /i/ and /u/.

Instructions:

Each subject was instructed as follows-

"Please say the vowel /a/ in your speaking voice till I say stop". The instructions were in Kannada (as all the subjects tested were using Kannada), supplemented by tactile cue and demonstration.

Before the start of the measurement, the instruments were checked for battery voltage, overload, and calibration as per instructions in the manual.

Then, the subject was asked to phonate the vowel and the signal or wave form on the HRSA screen was observed and stored.

Photographs-1 and 2, show the instrumental setup and glottal wave form respectively.

.*

On the HRSA display, when the function selected was "TIME", X-axis represented time in milliseconds, and Y-axis represented amplitude in divisions which could be converted into decibel value. The provision, in HRSA, of moving the cursor horizontally made it possible to measure time at any given point on X-axis. When the function selected was "INST", frequency was represented on X-axis and relative amplitude on Y-axis in the form of spectrum. This function was used to measure the fundamental frequency of phonation for the vowel in each subject.

By moving the cursor and looking at the display of the wave form, time in milliseconds was noted at different points like P1, P2, P3, P4, P5, P6 & P7. Using the same procedure the values for /i/ and /u/ were also obtained.



Photograph-1: High Resolution Signal Analyzer with Laryngograph.

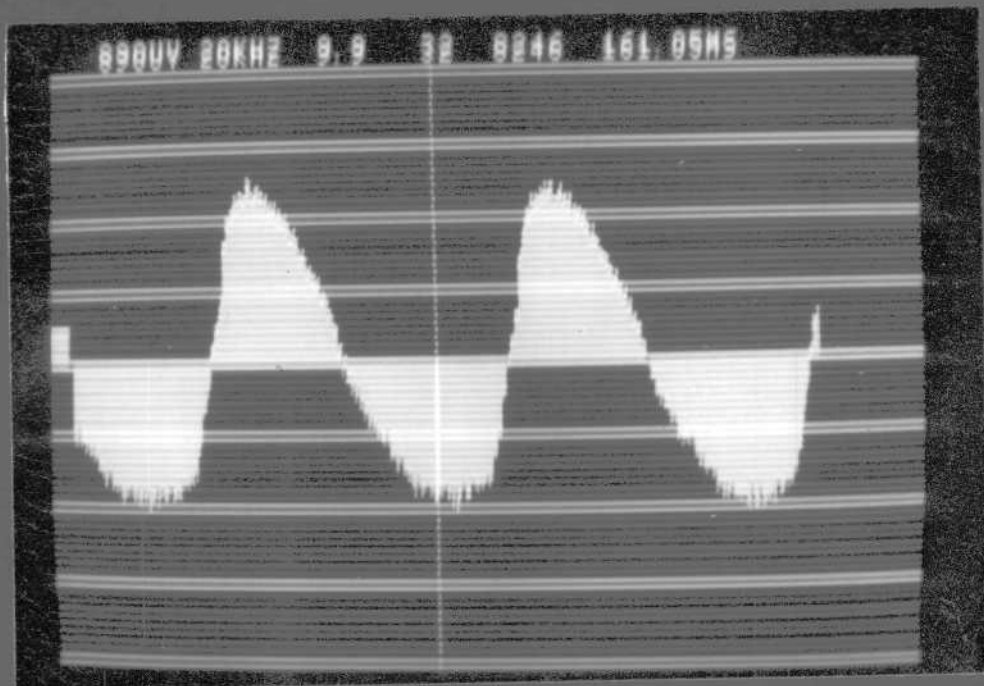

Photograph-2: Electroglottogram.
(Lx Wave form)

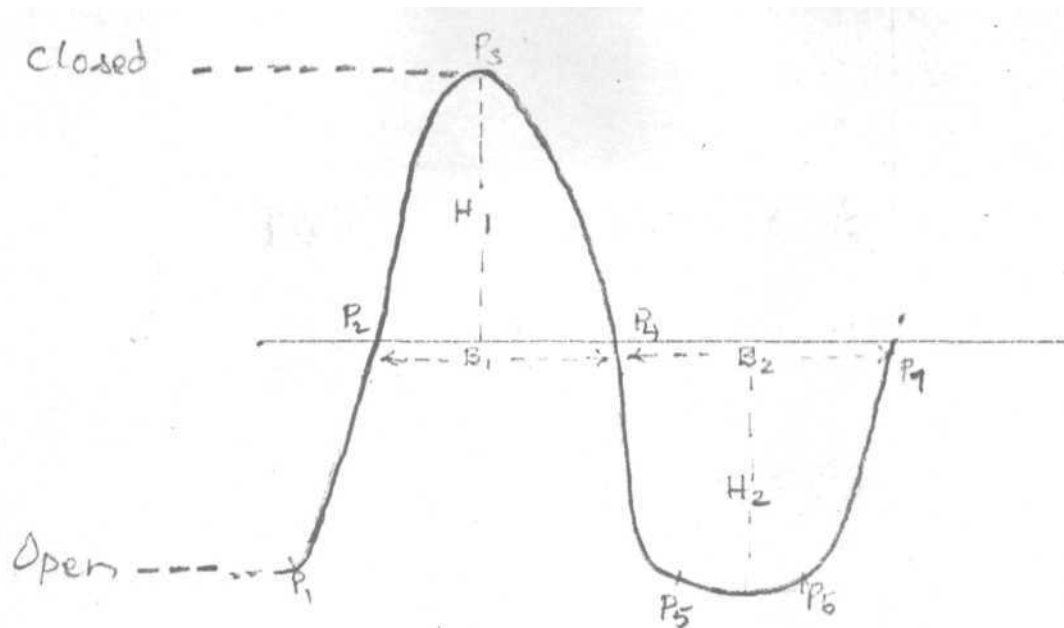

Fig.4: Characteristics of glottogram.

- P7-P4 = Open phase
- P5-P3 = Opening phase
- P3-P1 = Closing phase
- B1 = Base of the contact phase
- B2 = Base of the open phase
- H1 = Height of the contact phase
- H2 = Height of the open phase
- P7-P2 = Vibratory period (t)
- H1+H2 = Amplitude (a)

From this data, the following parameters were obtained:

1. Open Quotient (OQ):

$$OQ = \frac{\text{Open phase} \quad P7-P4}{\text{Vibratory period} \quad P7-P2}$$

2. Speed Quotient (SQ):

$$SQ = \frac{\text{Opening time} \quad P5-P3}{\text{Closing time} \quad P3-P1}$$

3. Speed Index (SI):

$$SI = \frac{SQ - 1}{SQ + 1}$$

4. "S" Ratio (SR):

$$\begin{aligned} \text{SR} &= \frac{\text{Area occupied by contact phase}}{\text{Area occupied by open phase}} \\ &= \frac{1/2 \text{ Height 1} \times \text{Base 1}}{1/2 \text{ Height 2} \times \text{Base 2}} \\ &= \frac{\text{H1} \times \text{B1}}{\text{H2} \times \text{B2}} \end{aligned}$$

B1 = (P4-P2) in mm, base of the contact phase

B2 = (P7-P4) in mm, base of the open phase

H1 = Height of the contact phase i.e. the number of vertical divisions where the positive peak had occurred (in mm)

H2 = Height of the open phase, i.e. the number of vertical divisions where the negative peak had occurred (in mm).

Five consecutive cycles, for each vowel, for each subject, were taken to obtain OQ, SQ, SI and SR.

5. Jitter (J):

To obtain this, the period (t) of each cycle (P7-P2) in ms, was determined for six consecutive cycles i.e. t1, t2, t3, t4, t5 and t6.

J is /t1-t2/, /t2-t3/, /t3-t4/, /t4-t5/ and /t5-t6/

Average J of six consecutive cycles was:

$$J = \frac{/t1-t2/ + /t2-t3/ + /t3-t4/ + /t4-t5/ + /t5-t6/}{5} \text{(in msec)}$$

This was used to determine J for each vowel in each subject.

To obtain this, the amplitude (a) of each cycle was measured for six consecutive cycles i.e. a1, a2, a3, a4, a5 and a6 and converted to decibel value.

S is /a1-a2/, /a2-a3/, /a3-a4/, /a4-a5/ and /a5-a6/

Average shimmer for six cycles was got by :

$$S = \frac{/a1-a2/ + /a2-a3/ + /a3-a4/ + /a4-a5/ + /a5-a6/}{5} \text{(in dB)}$$

5

This formula was used to determine shimmer for each vowel in each subject.

The data for all the above parameters were tabulated and subjected to statistical analysis.

RESULTS AND DISCUSSIONS

The purpose of the study was to measure the parameters of vocal fold vibration in the hearing impaired. The parameters studied were :

- Open Quotient (OQ)
- Speed Quotient (SQ)
- Speed Index (SI)
- "S" Ratio (SR)
- Jitter (J)

- Shimmer (S)

Table-2 and Graph-1, depicts the mean and standard deviation (in brackets) of OQ, SQ, SI, SR, J and S of the vowels /a/, /i/, /u/ in hearing impaired and normal subjects.

Parameter'S in a, i, u	Males		Females		
	Hearing impaired	Normals	Hearing impaired	Normals	
OQ	a	0.55 (0.06)	0.65 (0.12)	0.58 (0.08)	0.69 (0.12)
	i	0.55 (0.19)	0.67 (0.12)	0.57 (0.08)	0.66 (0.13)
	u	0.54 (0.07)	0.67 (0.12)	0.56 (0.08)	0.67 (0.11)
SQ	a	1.75 (0.77)	2.01 (0.74)	1.87 (0.98)	2.30 (0.59)
	i	1.97 (0.98)	1.72 (0.49)	2.20 (1.25)	2.24 (0.49)
	u	1.99 (0.66)	1.77 (0.53)	2.10 (1.33)	2.21 (0.44)
SI	a	0.21 (0.22)	0.42 (0.35)	0.21 (0.29)	0.49 (0.40)
	i	0.27 (0.22)	0.25 (0.12)	0.28 (0.28)	0.35 (0.12)
	u	0.29 (0.18)	0.26 (0.10)	0.30 (0.35)	0.35 (0.10)
SR	a	1.04 (0.26)	1.13 (0.10)	1.07 (0.42)	1.08 (0.16)
	i	1.23 (0.32)	1.14 (0.13)	1.09 (0.33)	1.09 (0.06)
	u	1.03 (0.26)	1.15 (0.11)	1.05 (0.30)	1.14 (0.13)

COMPARISON OF EGG PARAMETERS

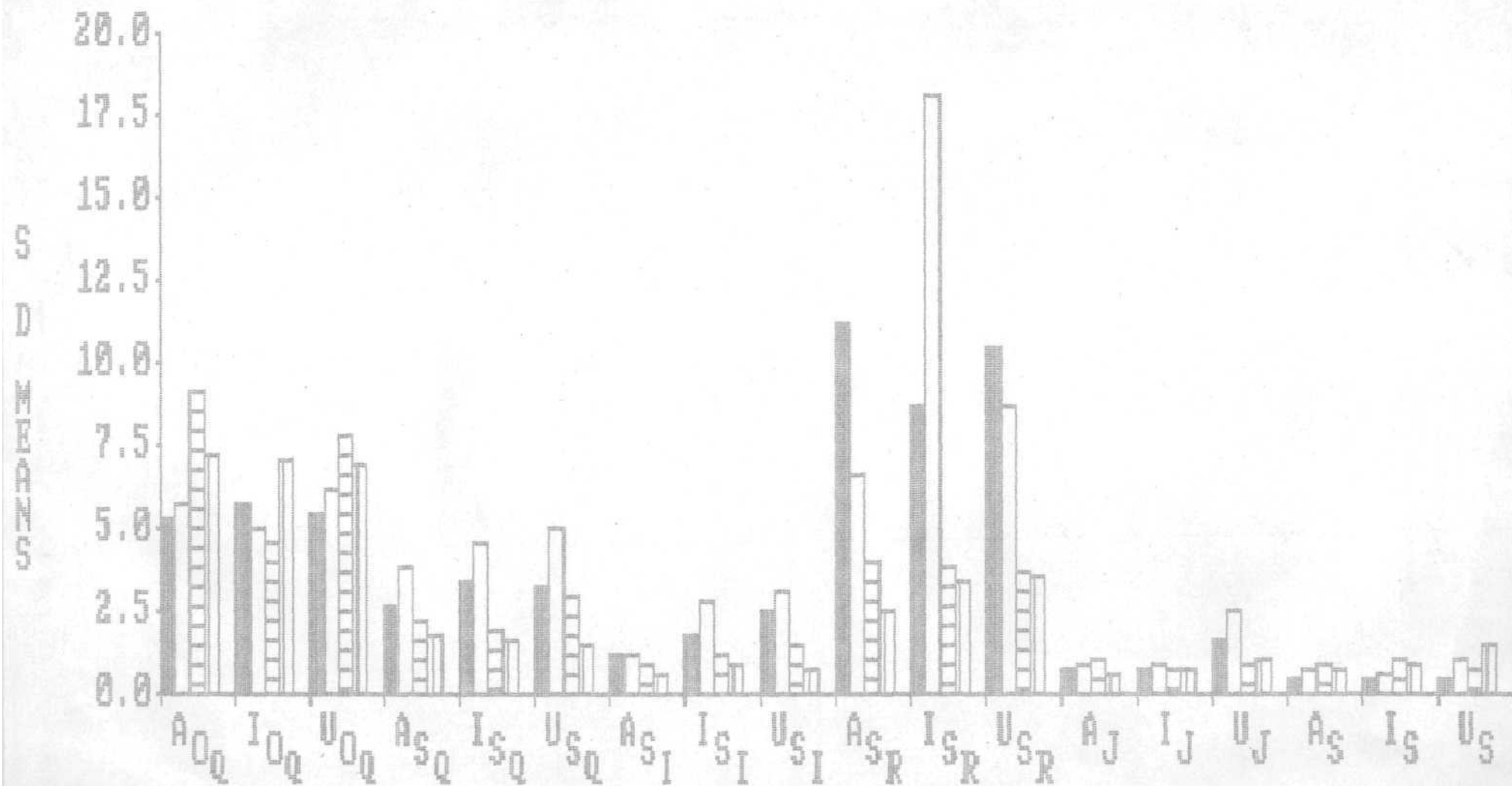

EGG PARAMETERS

MALE-N
 FEMALE-N
 MALE-H.I.
 FEMALE-H.I.

a	0.327 (0.302)	0.136 (0.192)	0.092 (0.134)	0.074 (0.061)
i	0.111 (0.131)	0.112 (0.138)	0.094 (0.117)	0.045 (0.045)
u	0.199 (0.199)	0.065 (0.038)	0.089 (0.077)	0.047 (0.022)
a	0.445 (0.464)	0.088 (0.156)	0.541 (0.700)	0.659 (0.748)
i	0.815 (0.782)	0.288 (0.638)	0.571 (0.575)	0.405 (0.641)
u	0.955 (1.162)	0.256 (0.536)	0.480 (0.307)	0.456 (0.442)

Table-2: Mean and Standard Deviation values of different parameters measured.

Open Quotient (OQ):

OQ in normal ranged from 0.43 to 0.80 with a mean of 0.65 and a standard deviation (SD) of 0.12 in males for the vowel /a/.

The hearing impaired males showed an OQ ranging from 0.43 to 0.66 with a mean of 0.55 and a SD of 0.06 for the vowel /a/.

The difference in the means of the OQ between normal and hearing impaired males for the vowel /a/ was 0.10. The statistical analysis showed that this difference was significant.

OQ in normal males for /i/ ranged from 0.47 to 0.83 with a mean of 0.67 and a SD of 0.12. In the hearing impaired males, OQ for /i/ ranged from 0.38 to 0.78 with a mean of 0.55 and a SD of 0.11.

The difference in the means of the OQ of /i/ between normal and hearing impaired males was 0.12. The statistical analysis revealed that the difference was significant.

OQ in normal males for the vowel /u/ ranged from 0.46 to 0.81 with a mean of 0.67 and a SD of 0.12. In the hearing impaired males, the OQ for /u/ ranged from 0.41 to 0.64 with a mean of 0.54 and a SD of 0.07.

The difference in the means of OQ for /u/ between the normal and hearing impaired males was 0.13 which was significant as depicted by statistical analysis.

In normal female subjects, the OQ for the vowel /a/ in ranged from 0.48 to 0.87 with a mean of 0.69 and a SD of 0.12. OQ in hearing impaired females for /a/ ranged from 0.42 to 0.69 with a mean and SD of 0.58 and 0.08 respectively.

The difference in females for OQ for /a/ between normal and hearing impaired was found to be 0.11 which was significant statistically.

OQ for /i/ in normal females ranged from 0.39 to 0.79 with a mean of 0.66 and a SD of 0.13. The OQ in hearing impaired females for /i/ ranged from 0.40 to 0.65 with a mean of 0.57 and a SD of 0.08.

The difference in the mean values for OQ of /i/ between normal and hearing impaired females was 0.08. This difference was significant statistically.

The OQ for the vowel /u/ in normal females ranged from 0.44 to 0.77 with a mean and SD of 0.67 and 0.11 respectively. The OQ for /u/ in hearing impaired females ranged from 0.38 to 0.67 with a mean of 0.56 and a SD of 0.08.

The difference in mean values for OQ for /u/ between normal and hearing impaired females was 0.11, which was statistically significant.

In general, the OQ in the hearing impaired was lesser than that in normal subjects for all the vowels and in both males and females. This implies that in the hearing impaired, the duration of the vibratory cycle for which the glottis is open was lesser than in normals.

	NH - M	NH - F
a	+	+
i	+	+
u	+	+

Table-3: Summary of significance relationship between normal and hearing impaired groups.

where NH-M = Significant difference between normal & hearing impaired males.
 NH-F = Significant difference between normal & hearing impaired females.

Thus, the hypothesis-2a, that there is no significant difference between normal and hearing impaired subjects in OQ for all the three vowels, has been refuted.

But Mashie (1984) reported "an abnormally wide glottal opening leading to excessive air expenditure". Forner and Hixon (1976), and Whitehead (1982) have reported that the hearing impaired spend more air and they use 100 cc/syllable (normals use 20-40 cc/syllable).

The results of the present study contradict the report by Mashie (1984). This may be because of differences in the methods used and the speech sample used in these two studies. This warrants further investigation.

Timcke et.al. (1950) stated that, "small OQ describes a condition in which strong, short glottal pulses excite the vocal tract to resonate high harmonics; the sharper the puff, the richer the glottal wave in the high frequency components or high harmonics characterize acoustically powerful efficient vocal tones. The presence of the number of harmonics needs to be studied in the light of the above report and findings of the present study.

Speed Quotient (SQ):

SQ in normal males ranged from 1.5 to 3.65 for /a/, with a mean and SD of 2.01 and 0.74 respectively. In hearing impaired males for /a/, SQ ranged from 0.78 to 3.37 with a mean of 1.75 and a SD of 0.77.

The difference between the normals and hearing impaired males in the mean SQ of /a/ was 0.26. This difference was not significant statistically.

In normal males, the SQ of /i/ ranged from 1.10 to 3.01 with a mean and SD of 1.72 and 0.49 respectively. SQ in hearing impaired males for the vowel /i/ ranged from 0.77 to 4.66 with a mean of 1.97 and a SD of 0.98.

The difference between the normal and hearing impaired males in the mean SQ of /i/ was 0.25, which was statistically not significant.

The SQ for /u/ in normal males ranged from 1.33 to 3.55 with a mean and a SD of 1.77 and 0.33 respectively. In the hearing impaired males, the value of SQ for /u/ ranged from 0.89 to 2.79, with a mean of 1.99 and SD of 0.66.

The difference in the mean values of SQ for /u/ between the normal and hearing impaired males was 0.22. This difference was found to be not significant statistically.

In normal females, the value of SQ for the vowel /a/ ranged from 1.46 to 3.93 with a mean and SD of 2.30 and 0.59 respectively. SQ for /a/ in the hearing impaired females ranged from 0.46 to 3.44, with a mean of 1.87 and SD of 0.98.

The difference in the mean values of SQ between the normals and hearing impaired females was 0.43. This difference was not significant statistically.

SQ for /i/ in normal females ranged from 1.16 to 2.76, with a mean and SD of 2.24 and 0.49 respectively. In the hearing impaired females, SQ for /i/ ranged from 0.73 to 5.17, with a mean of 2.20 and SD of 1.25 i.e. hearing impaired females varied more as a group from normal females in the SQ of /i/.

The difference in the mean values for SQ of /i/ between the normals and hearing impaired was 0.04, this was statistically not significant.

SQ for /u/ in normal females ranged from 1.30 to 2.88, with a mean and SD of 2.21 and 0.44 respectively. In the hearing impaired females SQ of /u/ ranged from 0.68 to 4.55 with a mean of 2.10 and a SD of 1.33.

The difference in the mean values of /u/ between the normal and hearing impaired females was 0.11, this difference was not statistically significant.

	NH-M	NH-F
a	-	-
i	-	-
u	-	-

Table-4: Summary of significance relationship of SQ between normal and hearing impaired.

Thus the hypothesis-2b, that there is no significant difference between normal and hearing impaired groups, has been accepted.

This finding, that there is no significant difference between the SQ in the hearing impaired and normal subjects, may be because the loudness of phonation between the two groups may be comparable and studies by Timcke et.al (1958) revealed that "as the loudness increased, the lateral displacement of the vocal folds also increased, as they were blown more vigorously apart".

Speed Index (SI):

In normal males, the value of SI for /a/ ranged from 0.07 to 1.40 with a mean and SD of 0.42 and 0.35 respectively. Si in hearing impaired males for /a/ ranged from -0.12 to 0.54 with a mean of 0.21 and a SD of 0.22.

The difference in the mean values of SI of /a/ between normal and hearing impaired males was 0.21, this was not statistically significant.

SI for the vowel /i/ in normal males ranged from 0.05 to 0.5 with a mean and SD of 0.25 and 0.12 respectively. In the hearing impaired, SI for /i/ ranged from -0.13 to 0.4b) with a mean of 0.27 and a SD of 0.22.

The difference in the mean values of SI between the normals and hearing impaired males was 0.02, which was not significant statistically.

In normal males, the SI for /u/ ranged from 0.15 to 0.56 with a mean and SD of 0.26 and 0.10 respectively. SQ in hearing impaired males for /u/ ranged from -0.06 to 0.17 with a mean of 0.29 and a SD of 0.18.

The difference between the normal and the hearing impaired males was 0.03, the difference was not significant statistically.

In normal females, the range of SI for /a/ was 0.28 to 1.9 with a mean of 0.49 and a SD of 0.40. SI in hearing impaired females for /a/ ranged from -0.37 to 0.56 with a mean of 0.21 and a SD of 0.29.

The difference of mean values of the SI of /a/ between normals and the hearing impaired was 0.28. This difference was found to be significant statistically.

SI for /i/ in the normal females ranged from 0.08 to 0.47, with a mean and SD of 0.35 and 0.12 respectively. In hearing impaired females, the SI value ranged from -0.15 to 0.68, with a mean of 0.28 and a SD of 0.28.

The difference between normal and hearing impaired females in the mean values of SI for /i/ was 0.07, which was not statistically significant.

SI for /u/ in the normal females ranged from 0.13 to 0.46, with a mean and SD of 0.35 and 0.10 respectively. In the hearing impaired females, SI for /u/ ranged from -0.19 to 1.13, with a mean of 0.30 and a SD of 0.35.

The difference between the normal and the hearing impaired groups in the mean values of SI for /u/ was 0.05, which was not statistically significant.

	NH-M	NH-F
a	-	+
i	-	-
u	-	-

Table-5: Summary of significance relationship of SI between normal and hearing impaired.

Thus the hypothesis 2c, that there is no significant difference between SI in normal and hearing impaired, has been accepted.

It has been found that SI value ranges from -1 to +1. It is a relative ratio, where positive values indicate more of opening time and negative value means more of closing time of the vibratory cycle, a zero value indicates equal timing.

The mean SI values for all the vowels in the normal and hearing impaired groups revealed that in the total vibratory cycle, opening time was longer, as expected.

"S" Ratio (SR):

In normal males, the SR for /a/ was found to be ranging from 0.93 to 1.2b with a mean of 1.13 and a SD of 0.10. SR in hearing impaired males for /a/ ranged from 0.43 to 1.35, with a mean of 1.04 and a SD of 0.26.

The difference between the means of SR for /a/ in normals and hearing impaired was 0.09, which was not statistically significant.

SR in normal males for /i/ was ranging from 0.94 to 1.35, with a mean of 1.14 and a SD of 0.13. In hearing impaired males, the SR for /i/ ranged from 0.80 to 1.89, with a mean and SD of 1.23 and 0.32 respectively.

The difference between the means of SR for the vowel /i/ in normals and hearing impaired males was 0.09, this difference was not significant statistically.

The value of SR in normal males for the vowel /u/ was ranging from 1.01 to 1.42, with a mean and SD of 1.15 and 0.11 respectively. SR in hearing impaired females for /u/ ranged from 0.44 to 1.56, with a mean of 1.03 and SD of 0.26.

The difference in the means of SR of /u/ between normal and hearing impaired males was 0.12, which was not statistically significant.

In normal females, the SR value for /a/ varied from 0.53 to 1.19, with a mean and SD of 1.08 and 1.16 respectively. SR in the hearing impaired females for /a/ varied from 0.63 to 2.04, with a mean of 1.07 and SD of 0.42.

The difference in the means of SR for /a/ between the normal and hearing impaired females was 0.01, which was not significant statistically.

SR in normal females for /i/ varied from 0.96 to 1.15, with a mean and SD of 1.09 and 0.06 respectively. In the hearing impaired females, SR for /i/ ranged from 0.76 to 1.82, with a mean of 1.09 and a SD of 0.33.

The difference between normal and hearing impaired females in the mean values of SR of /i/ was zero.

In normal females, the SR values of /u/ ranged from 0.9 to 1.48, with a mean and SD of 1.14 and 0.13 respectively. In hearing impaired females, SR of /u/ ranged from 0.71 to 1.80, with a mean of 1.05 and a SD of 0.30.

The difference between the means of SR for /u/ in normal and hearing impaired females was 0.09, which was not statistically significant.

	NH-M	NH-F
	-	-
a	-	-
i	-	-

Table-6: Summary of significance relationship of SR between normal and hearing impaired.

Thus the hypothesis-2d, that there is no significant difference in SR between normal and hearing impaired groups, has been accepted.

SR gives information combining the relative surface and duration of the vocal fold contact during one vibratory cycle. In the present study, the SR in hearing impaired was not significantly different from normal subjects, and therefore the contact pattern of vocal folds is not significantly modified in the hearing impaired group.

The normal males showed a jitter (msec) which ranged from 0.005 to 0.724, for the vowel /a/. The mean and SD was 0.136 and 0.192 respectively.

In the hearing impaired males, jitter of /a/ ranged from 0.006 to 0.562, with a mean of 0.327 and SD of 0.302.

The difference between the means of J in /a/ in normal and hearing impaired males was 0.191, which was not statistically significant.

Jitter value for the vowel /i/ in normal males ranged from 0.016 to 0.550, with a mean and SD of 0.112 and 0.138 respectively. In hearing impaired males, the vowel /i/ had a J ranging from 0.00 to 0.564, with a mean of 0.111 and a SD of 0.131.

The difference between the means of jitter for /i/, in the normal and the hearing impaired males was 0.001, which was statistically not significant.

Jitter of /u/ in normal males ranged from 0.024 to 0.120, with a mean and SD of 0.065 and 0.038 respectively. In the hearing impaired males, the jitter of /u/ ranged from 0.048 to 0.655, with a mean of 0.199 and SD of 0.199.

The difference between the means of the jitter in normal and hearing impaired males, for the vowel /u/, was 0.134, which was statistically significant. The jitter was more in the hearing impaired than normal males for /u/.

Sridhara (1986) reported a higher jitter in males (0.060 msec) compared to females (0.046 msec), for the vowels /a/, /i/ and /u/, in normals. Report by Monsen, Engebretson and Vemula (1979) revealed that, jitter was higher in the hearing impaired. They also stated that the large number of jitter and shimmer constitutes an incipient form of diplophonia.

In normal females, jitter values of /a/ ranged from 0.010 to 0.244, with a mean and SB of 0.074 and 0.061 respectively. Jitter of /a/ in the hearing impaired females ranged from 0.006 to 0.562, with a mean of 0.092 and a SB of 0.134.

The difference in means of the jitter of /a/ between normal and hearing impaired females was 0.018, which was not statistically significant.

Jitter value of /i/ in normal females ranged from 0.0 to 0.188, with a mean and SB of 0.045 and 0.045 respectively. In hearing impaired females, the jitter range was from 0.004 to 0.412, with a mean of 0.094 and SB of 0.117.

The difference between the normal and hearing impaired females, in the jitter of /i/ was 0.049, which was not significant statistically.

Jitter value in normal females for the vowel /u/ ranged from 0.008 to 0.09, with a mean and SB of 0.047 and 0.022 respectively. In the hearing impaired females, the jitter for /u/ was ranging from 0.0 to 0.302, with a mean of 0.089 and SB of 0.077.

The difference between the means of the jitter in normal and hearing impaired females for the vowel /u/ was 0.042, which was not statistically significant.

	NH-M	NH-F
a	-	-
i	-	-
u	+	-

Table-7: Summary of significance relationship of J between normal and hearing impaired.

Thus the hypothesis-2e, that there is no difference between the J of the normal and hearing impaired has been accepted.

The result in the present study, that vowel /u/ was with significantly more jitter in hearing impaired than normal subjects supports Monsen et.al. (1979) study. Monsen et.al. have found the rate of jitter to be higher for hearing impaired.

Shimmer (S):

In normal males, the shimmer (dB) ranged from 0.0 to 0.40, with a mean of 0.088 and SD of 0.156. The hearing impaired males showed a shimmer of /a/ ranging from 0.032 to 1.36 with a mean of 0.445 and 3D of 0.464.

The difference between the means of normal and hearing impaired males, in the shimmer of /a/ was 0.35%. This was significant statistically.

Shimmer in normal males for /i/ ranged from 0.0 to 2.2, with a mean of 0.288 and SD of 0.638. In the hearing impaired males, the shimmer ranged from 0.00 to 2.4 for /i/, with a mean and SD of 0.815 and 0.782 respectively.

The difference in means of shimmer in /i/ between normal and hearing impaired males was 0.527, which was not statistically significant.

The shimmer for /u/ in normal males ranged from 0.0 to 0.8, with a mean of 0.256 and SD of 0.536. In the hearing impaired males, the shimmer of /u/ was ranging from 0.0 to 2.4, with a mean of 0.955 and SD of 1.162.

The difference between the means of shimmer in /u/ in normal and hearing impaired males was 0.699, which was not statistically significant.

In normal females, the shimmer of /a/ was ranging from 0.00 to 2.80, with a mean and SD of 0.659 and 0.748 respectively. Shimmer of /a/ in the hearing impaired females ranged from 0.16 to 2.96, with a mean of 0.541 and SD of 0.70.

The difference between the means of shimmer in /a/ in normal and hearing impaired females was 0.118, which was statistically not significant.

Shimmer in /i/, in the normal females ranged from 0.0 to 2.0, with a mean of 0.405, and SD of 0.641. In hearing impaired, the shimmer in /i/ was ranging from 0.08 to 2.0, with a mean and SD of 0.571 and 0.575 respectively, in females.

0.116 was the difference in mean values of shimmer in /i/ between normal and the hearing impaired females. This difference was statistically not significant.

The shimmer in /u/ for normal males was found to be ranging from 0.00 to 1.2, with a mean of 0.456 and SD was 0.442. Shimmer in the hearing impaired females for /u/ ranged from 0.08 to 1.16, with a mean of 0.480 and SD of 0.307.

The difference between the means of shimmer in /u/ in the normal and hearing impaired females was 0.024, which was not significant statistically.

	NH-M	NH-F
a	+	-
i	-	-
u	-	-

Table-8: Summary of significance relationship of S between normal and hearing impaired.

Thus the hypothesis-2f, that there is no significant difference between the S of normal and hearing impaired groups has been accepted.

Monsen et.al. (1979) reported an average shimmer in the hearing impaired which was within the normal range i.e. 0.02 to 0.06dB, but a few had double this value. The present study agrees with Monsen et.al's study except for the greater shimmer in hearing impaired males, in the vowel /a/. Monsen et.al. further stated that the large amounts of jitter and shimmer constituted an incipient form of diplophonia.

The means of the parameters like OQ, SQ, SI, SR, J and S were compared between males and females in each group i.e., in the hearing impaired and normal groups.

The means of OQ in normal males and OQ in normal females were compared, a difference of 0.04, was evident, which was statistically not significant. The difference between the mean OQ of hearing impaired males and females, was 0.03, which again is not significant for the vowel /a/.

The mean OQ of /i/ between normal males and females differed by 0.01, and that between hearing impaired males and females was 0.02. Statistical analysis showed that this difference was not significant.

When the means of OQ of /u/ were compared between normal males and females, the difference was absent. But in hearing impaired males and females, the mean OQ of /u/ differed from each other by 0.02, though the difference was not significant statistically.

	N-MF	H-MF
a	—	—
i	—	—
u	—	—

Table-9: Summary of significance relationship of OQ between males & females in normal & hearing impaired groups.

N-MF = Significance difference between normal males & females.

H-MF = Significance between hearing impaired males & females.

-Therefore, there was no significant difference between male and female subjects in both normal and hearing impaired groups in the vowels /a/, /i/ and /u/ i.e., sex is not a variable for OQ. Thus the hypothesis-1a and 1b have been accepted.

Speed Quotient (SQ):

Between males and females, when the means of SQ of /a/ were compared in the normal group, the difference was found to be 0.29, which was statistically not significant.

When the means of SQ of /a/ were compared in the hearing impaired between males and females, the difference was found to be 0.23, which was not significant statistically.

The mean values of SQ of /i/ when compared between males and females of the normal group, the difference was found to be 0.52, which was significant statistically.

In the hearing impaired,; when the means of SQ of /i/ were compared, the difference was found to be 0.23, statistically not significant.

When the means of SQ for /u/ was compared between normal males and females, the difference obtained was 0.44, which was found to be statistically significant.

In the hearing impaired group, when males and females were compared for SQ of /u/, the difference was found to be 0.22, which was statistically not significant.

	N-MF	H-MF
a	-	-
i	+	-
u	+	-

Table-10: Summary of significance relationship of SQ between males & females in normal & hearing impaired.

Thus the hypothesis-1b is accepted (i.e. no significant difference between males and females in the hearing impaired group). But the hypotheis -1a has been refuted (i.e. there is significant difference between males and females in the normal group).

The present results for /i/ and /u/ in normal group contradict Luschinger's (1965) report that "SQ is not influenced by the sex (other variables not influencing SQ were pitch, register, vocal type)".

SpeedIndex(SI):

In normal group, when, the males and females were compared for the means of SI of /a/, the difference was noted to be 0.07, which was statistically not significant.

The difference in the means of SI of /a/ in the hearing impaired group, between males and females, was found to be zero.

The males and females in the normal group differed in mean SI of /i/ by 0.10, which was statistically significant. The males and females in the hearing impaired group differed in their mean scores of SI of /i/ by 0.01, which was statistically not significant.

When the males and females in the normal group were compared for mean Si of /u/, they differed by 0.09, this difference was statistically significant.

In the hearing impaired group, when the mean SI of /u/ were compared, the difference was found to be 0.01, which was not statistically significant.

	N-MF	H-MF
a	-	-
i	+	-
u	+	-

Table-11: Summary of significance relationship of SI between males & females in normal & hearing impaired groups.

SI was significantly different between the males and females in the normal group for the vowels /i/ and /u/. SI was significantly more in females than in males.

Thus the hypothesis-1b has been accepted (i.e., there is no significant difference between males & females in hearing impaired group). The hypothesis-1a has been refuted (i.e., there is significant difference between males & females in normal group).

"S" Ratio (SR):

When the means of SR for /a/ was compared between the males and females in normal group, the difference was found to be 0.05, which was not significant statistically.

The males and females in hearing impaired group differed by 0.03, which was not statistically significant when the means of SR for /a/ was compared.

The SR mean values were found to be not significantly different, when compared between normal males and females for the vowel /i/ (difference was 0.05).

The means of SR for /i/ when compared between the males and females in the hearing impaired group, the difference was 0.14, which was not statistically significant.

In the normal males and females, the difference in mean SR of /u/ was found to be 0.01, which was statistically not significant.

The difference between the males and females of the hearing impaired group was found to be 0.02, for mean SR of the vowel /u/. This difference was not statistically significant.'

	N-MF	H-MF
a	-	-
i	-	-
u	-	-

Table-12: Summary of significance relationship of SR between males & females in normal & hearing impaired group.

Thus the hypotheses-1a and 1b have been accepted (i.e. there is no significant difference in SR between males and females for the three vowels in normal and hearing impaired). Therefore, sex may not be a variable with reference to SR.

Jitter (J):

Between males and females, when the means of jitter (msec) of /a/ were compared in the normal group, the difference was found to be 0.062, and statistically not significant.

In the hearing impaired group, when the mean jitter of /a/ was compared between males and females, the difference was found to be 0.235, which was statistically significant.

When the males and females in the normal group were compared for the means of jitter in /i/, the difference was found to be 0.049, not significant statistically.

In the hearing impaired group, when the mean jitter of /i/ was compared between males and females, it differed by 0.017, which was not statistically significant.

The means of the jitter of /u/ in the males and females of the normal group differed by 0.018, which was statistically not significant.

When the means of the jitter of /u/ were compared between males and females of the hearing impaired group, the difference was 0.110, which was not statistically significant.

	N-MF	H-MF
a	-	+
i	-	-
u	-	-

Table-13: Summary of significance relationship of J between males & females in normal & hearing impaired groups.

Jitter was significantly different from the males and females of the hearing impaired group, it was more in males only for the vowel /u/. Phonation of /a/ in the hearing impaired males was less periodic than that of females, as the results of the present study revealed.

The hypothesis-1a has been accepted (i.e. there is no significant difference in J between males and females in normal group). The hypothesis-1b has also been accepted (i.e. there is no significant difference between males and females in the hearing impaired group).

Shimmer (S):

When the means of the shimmer (dB) of the vowel /a/ was compared, between the males and females of the normal group, the difference was found to be 0.571, and was significant statistically.

The means of shimmer of /a/ was compared between the i males and females in the normal group, the difference was found to be 0.096, and statistically not significant.

Between the males and females of the normal group, the mean shimmer for /i/ differed by 0.117, which was not significant statistically.

The means differed between the males and females of the hearing impaired group, for the vowel /i/ by 0.244, this difference was found to be not significant statistically.

The means of the shimmer of /u/, when compared between normal males and females, differed by 0.200, which was statistically not significant. When the means of the shimmer of /u/ between the males and females were compared in the hearing impaired group the difference was 0.475. Statistically the difference was not significant.

	N-MF	H-MF
a	+	-
i	-	-
u	-	-

Table-14: Summary of significance relationship of S between males and females in normal and hearing impaired group.

Within the normal group, there was difference in the shimmer for the vowel /a/ between males and females (Shimmer in females was larger).

Thus the hypothesis-1a and 1b, has been accepted (i.e. there is no significant difference between males and females in normal and hearing impaired groups).

Thus it may be concluded that -

1. OQ in the hearing impaired was significantly lesser than in normal subjects in the vowels /a/, /i/ and /u/, in both males and females. Within the group, there was no significant difference between males and females.

2. SQ was not significantly different between normal and hearing impaired subjects for the vowels /a/, /i/ and /u/, in both males and females. Within the groups, there was significant difference in SQ between males and females in normals, but SQ was not significantly different between males and females in hearing impaired group.

3. SI was not significantly different between normal and hearing impaired males and females. Between males and females, there was no significant difference in the SI, in hearing impaired, but was different for the three vowels in normal group.

4. SR was not significantly different between hearing impaired and normal groups. Within groups, males and females did not differ in SR.

5. Jitter was not significantly different between hearing impaired and normal in the three vowels /a/, /i/ and /u/. Between males and females in normal group, there was no significant difference in the jitter of /a/, /i/ and /u/. In the hearing impaired, there was no significant difference between males and females in the jitter.

6. Shimmer did not differ significantly between normal and hearing impaired for the vowels /a/, /i/ and /u/ in both males and females was not significantly different. Between the males and female:; in the hearing impaired group and in normal group there was no significant difference in shimmer for /a/, /i/ and /u/.

This information can be used in therapy for correcting the voice of the hearing impaired. Visual display of the normal wave form can be used for providing the modal, so that the hearing impaired can try to approximate the wave shape and to improve the voice.

CHAPTER V

SUMMARY AND CONCLUSIONS

"Deafness, even profound deafness, does not prevent an individual from producing voice. However, the loss of hearing does affect the control of voice production, and when people listen to the speech of a deaf person, a typical reaction is that the speaker's voice sounds 'abnormal'". (Monsen et.al. 1979)

In order to investigate the effect of hearing impairment on vocal function, it is necessary to observe the glottal wave form separately from the resonance effect of the vocal tract. Therefore, in the present study, electroglottography was used to investigate the vocal fold vibrations during phonation, in hearing impaired individuals.

Fifteen male and fifteen female hearing impaired with a mean age of 23.27 yearn and 20.77 years respectively, served as subjects. Age ranged from 15-40 years in males, and 15-29 years in females. All subjects had a hearing level of not less than 70dBHL in the better ear, with no significant associated problems. Electrolaryngograph (Kay Elemetrics Corporation) and High Resolution Signal Analyser (B & K Type 2033) were used for measurement of the parameters like Open Quotient (OQ), Speed quotient (SQ), Speed Index (SI), "S" Ratio (SR), Jitter (J) and Shimmer (S).

The above parameters were studied in three vowels /a/, /i/ and /u/, keeping pitch and intensity of phonation constant, as far as possible.

After the statistical analysis of the data thus obtained, the following conclusions were drawn:

1. The mean OQ for the vowels /a/, /i/ and /u/ was 0.55, 0.56 and 0.55 in males, and 0.58, 0.57 and 0.56 in females.

a) There was no significant difference between males and females, both in normal and hearing impaired groups.

b) There was significant difference between normal and hearing impaired groups for all the three vowels /a/, /i/ and /u/. The mean value of OQ was lower in hearing impaired than in normal subjects.

2. The mean of SQ for the vowels /a/, /i/ and /u/ was 1.75, 1.97 and 1.99 in males, and 1.87, 2.20 and 2.10 in females.

a) There was no significant difference in the mean SQ between males and females in hearing impaired, but normal male and female subjects differed significantly.

b) There was no significant difference between the SQ of /a/, /i/ and /u/ in normal and hearing impaired subjects.

3. The mean SI for the vowels /a/, /i/ and /u/ was 0.22, 0.27 and 0.30 in males, and 0.21, 0.28 and 0.30 in females.

a) There was no significant difference in the mean SI between males and females in hearing impaired group. But there was difference in normal group between males and females.

b) There was no significant difference in the mean SI between normal and hearing impaired subjects for the vowels /a/, /i/ and /u/.

4. The mean SR for the vowels /a/, /i/ and /u/ was 1.04, 1.24 and 1.03 in males, and .1.07, 1.09 and 1.05 in females.

a) There was no significant difference in the mean SR between male and female subjects, in both normal and hearing impaired groups, for the vowels /a/, /i/ and /u/.

b) There was no significant difference between normal and hearing impaired subjects in SR for the vowels /a/, /i/ and /u/.

5. The mean values of Jitter for the vowels /a/, /i/ and /u/ was 0.326, 0.111 and 0.199 msec. in males, and that in females was 0.092, 0.094 and 0.089 msec.

a) There was no significant difference in the mean jitter of the vowels /a/, /i/ and /u/ between males and females in normal and hearing impaired groups.

b) For the vowels /a/, /i/ and /u/ there was no significant difference between normal and hearing impaired groups.

6. The mean shimmer for the vowels /a/, /i/ and /u/ in hearing impaired males was 0.445, 0.815 and 0.955dB, and that in females was 0.541, 0.571 and 0.480dB respectively.

a) There was no significant difference in the mean shimmer for the vowels, between males and females, both in normal and hearing impaired groups.

b) For the vowels /a/, /i/ and /u/, there was no significant difference between normal and hearing impaired groups.

Recommendations:

1. To investigate on a larger sample of different age groups, varying degrees and types of hearing loss and different age of onset.
2. To include other parameters.
3. To delineate the developmental changes in the parameters in the hearing impaired.
4. To observe the effect of modifying the deviant parameters on the improvement of voice quality in the hearing impaired individuals.

BIBLIOGRAPHY

- "ARNOLD AND LUSCHINGER (1965): 'Voice-speech-language, clinical communicology : Its physiology and pathology". Wordsworth Publishing Co., Inc. California.
- BORDEN AND HARRIS (1980): "Speech Science Primer Physiology, Acoustics, and Perception". Williams and Wilkins, Baltimore.
- DAVIS AND HARDICK (1981): "Rehabilitative audiology for children and adults". John Wiley and Sons, Inc.
- ENGBRETSON, MONSEN, VEMULA (1979): "Some effects of deafness on the generation of voice". Journal of Acoustical Society of America, Vol. 66(6), 1680-1690.
- FOURCIN, A. (1981): "Laryngographic assessment of phonatory function". ASHA Reports, II Reprint, Chap. 10, 116-128.
- _____ AND ABBERTON (1972): "First application of a new laryngograph". Volta Review, Vol. 74(3), 161-176.
- GILBERT AND CAMPBELL (1978): "Voice Onset Time in the speech of hearing impaired". Folia Phoniatica, Vol.30(1), 67-81.
- _____, POTTER, HOODIN (1984): "Laryngograph as a measure of vocal fold contact area". JSHR, Vol.27, 178-182..
- GULIAN, HINDS, NIMMO-SMITH (1986): "Modifications in deaf children's vowel production : perceptual evidence". British Journal of Audiology, Vol. 20(3), 181-194.
- HIRANO (1981): "Clinical examination of voice". Disorders of human communication, 5, Springer Verlagwien, New York.
- HAJI, BAER, HORIGUDU, GOULD (1986): "Frequency and amplitude perturbation analysis of EGG during sustained phonation". JASA, Vol. 80(1), 58-62.
- HORII, Y. (1982): "Jitter and Shimmer differences among sustained vowel phonations". JSHR, Vol.25(1), 12-14.
- , ITOH, DANILOFF, BINNIE (1982): "Selected aerodynamic characteristics of deaf individuals during various speech and nonspeech tasks". Folia Phoniatica, Vol.34(4), 191-209.
- & HEIBERGER (1982): "Jitter and shimmer in sustained phonation' in "Speech and language - Advances in Basic Research and Practice". Edited by Lass, Vol.7, Academic Press, 299-332, New York.

- JONES, C. (1967): "Deaf voice - A description derived from a survey of the literature". *Volta Review*, Vol.69(8), 507-508, 539-540.
- KITZING, SONNESSON (1974): "A photoglottographical study of female vocal folds during phonation". *Folia Phoniatica*, Vol.26, 138-149.
- LING (1976): "Speech and the hearing impaired child : Theory and Practice". The Alexander Graham Bell Association for the Deaf, inc. Washington.
- LECLUSE, BROCAAR, VERSCHUURE (1975): "The electroglottography and its relation to glottal activity". *Folia Phoniatica*, Vol.27(3), 215-224.
- MASHIE, CONTURE (1983): "Deaf speakers' laryngeal behaviour". *JSHR*, Vol.26 Dec., 550-559.
- MONSEN (1979): "Acoustic qualities of phonation in young deaf children". *JSHR*, Vol.22, 270.
- McGARR (1983): "The intelligibility of deaf speech to experienced and unexperienced listeners". *JSHR*, Vol.26, 451-458.
- _____ & OSBERGER (1982): "Speech production characteristics of the hearing impaired". Chap. in the book "Speech and Language" by Lass, Vol.8, Pub. Academic Press, 222-285, New York.
- MULGRAVE, GILMAN, PRONOVOST (1954): "Speech : A handbook of Voice Training Diction and Public Speaking". Barnes & Noble, Inc. New York.
- NICKERSON, R.S. (1975); "Characteristics of the speech of deaf persons". *Volta Review*, Vol.77(6), 342-362.
- PERKINS (1977): "Speech Pathology : An applied behavioral science". 2nd Edn. The CV Mosby Co. St. Louis.
- RAJANIKANTH, B.R. (1986): "Acoustic analysis of the speech of the hearing impaired". A Master's Dissertation submitted to the Univ. of Mysore.
- SMITH et.al. (1978): "Vocal roughness and jitter characteristics of vowels produced by esophageal speakers". *JSHR*, Vol.21, 240-248.

- SMITH, C.R. (1975): "Residual hearing and speech production in deaf children". JSHR, Vol.18(4), 795-811.
- SRIDHARA, R. (1986): "Glottal wave forms in normals". A Master's Dissertation submitted to the Univ. of Mysore.
- STATHOPOULOS, DUCHAN, SONNENMEIER, BRUCE (1986): "Intonation and pausing in deaf speech". Folia Phoniatic, Vol.38(1), 1-11.
- WECHSLER, E. (1977): "A laryngographic study of voice disorders". BJDC, Vol.12(1). 9-22.
- WEST (1947): "The pathology of speech and rationale of its rehabilitation". Harper and Bros. New York.
- WHITEHEAD et.al. (1977): "Fundamental frequency characteristics of the adult hearing impaired". ASHA.

\\ \$\$\$ ///

APPENDIX
ELECTROGLOTTOGRAPHY (EGG)

E.G.G. was first reported by Fabre (1957), The technique makes use of motion-induced variation in the electrical impedance between two electrodes placed superficially on either side of the thyroid cartilage. The electrodes are ordinarily held in contact by throat band. Each electrode has a guard ring and an inner conductor, made from standard printed circuit card material and, in themselves, involve no active component. Electrical voltage of small magnitude but of high frequency (0.5-10MHz) is applied to one electrode, the other electrode serves as current pick-up.

The transverse electrical impedance varies with opening and closing of the glottis, and results in variation of the electrical current in phase with the vibratory phases of the vocal fold. When the vocal folds are lateral, impedance is more, and when they are medial, impedance is lesser. Resulting wave form of variation of impedance is glottogram or laryngogram (Lx). It provides information concerning frequency of excitation of vocal tract during voicing, more accurately than any other signal. Clinically, Lx can be recorded on simple equipment and it is quite unaffected by acoustic noise. (Fourcin, 1974)

Electrolayngograph (Kay Elemetrics Corporation). This is a portable laryngograph with one pair of gold-plate electrodes, three elastic neck bands and an internal large capacity nickel-cadmium battery together with a separate mains operated battery charger.

Specifications:

Output Voltage Range: 6V pp maximum down to 40mv pp noise

Output impedance : 150 Ohms

Band Width : +/- 0.5dB between 10Hz to 5KHz

Signal to noise ratio: depending on speaker about 30 to 40dB.

Internal Voltage levels: + and - 3V to + and - 4.5V

Power source : PP 9 size rechargeable Ni-Cd batt,
8.4V/1.2AH.

Use with one charge: 24 hours of continuous use

Battery check indicator: provided by bar display

Output level indicator: 30dB range bar display

Output level control : Via a linear control

(Information regarding Specifications was collected from the ELG instruction manual provided by Kay Elemetrics Corporation).

/// @@@ ///