

**Perception of Spectrally Enhanced Speech through
Comping in Individuals with Cochlear Hearing Loss**

Deepthi, M

Register No. 10AUD009

A Dissertation Submitted in Part Fulfillment of Final Year

Master of Science (Audiology),

University of Mysore, Mysore



All India Institute of Speech and Hearing

Manasagangothri, Mysore-570006

May 2012

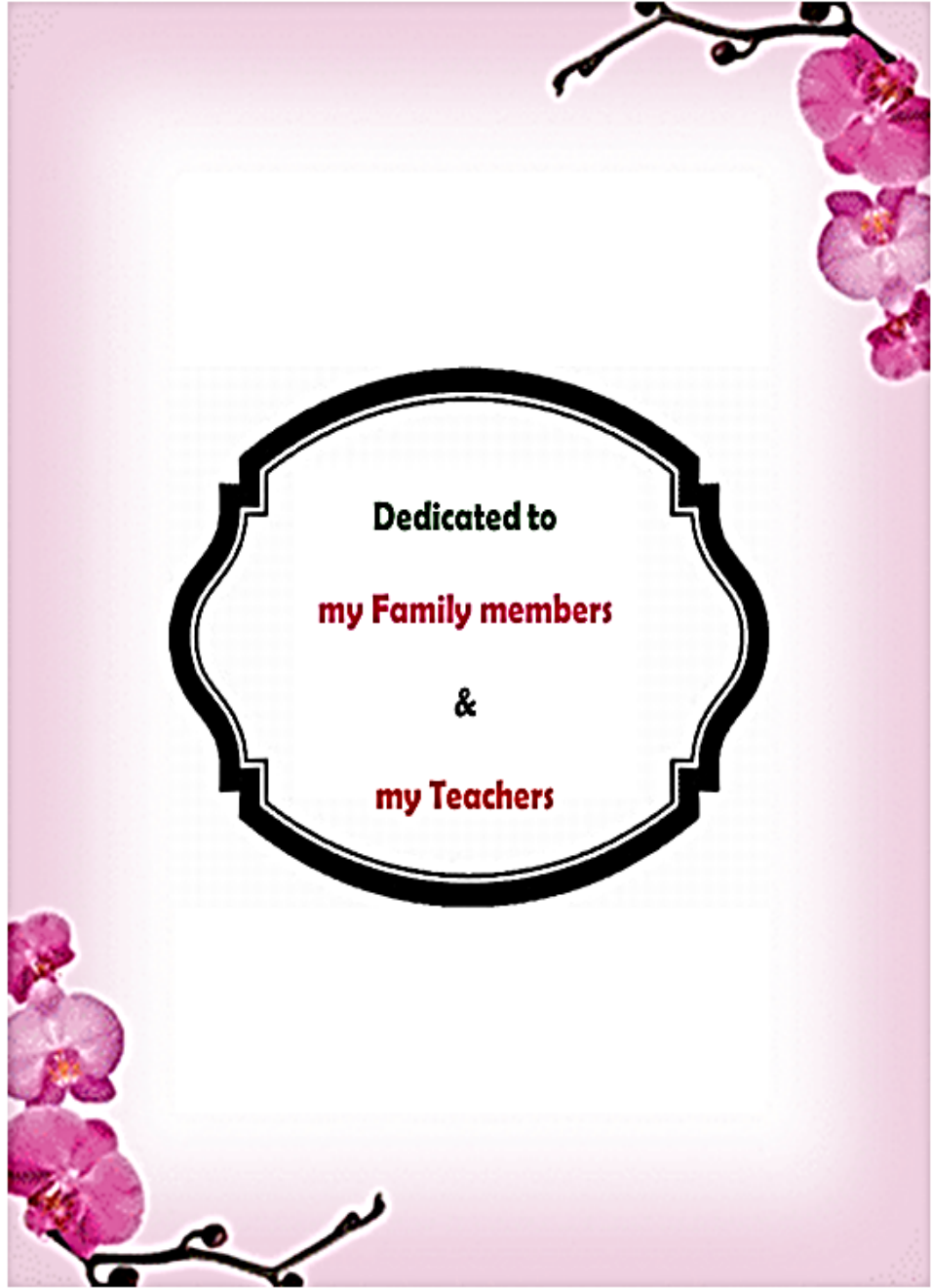

Dedicated to

my Family members

&

my Teachers

CERTIFICATE

This is to certify that this dissertation entitled **“Perception of Spectrally Enhanced Speech through Comanding in Individuals with Cochlear Hearing Loss”** is the bonafide work submitted in part fulfillment for the Degree of Master of Science (Audiology) of the student with Registration No.: 10AUD009. This has been carried out under the guidance of a faculty of this institute and has not been submitted earlier to any other University for the award of any other Diploma or Degree.

Dr. S. R. Savithri

Director

Mysore

May, 2012

All India Institute of Speech and Hearing,

Manasagangothri, Mysore- 570006

CERTIFICATE

This is to certify that this dissertation entitled **“Perception of Spectrally Enhanced Speech through Companding in Individuals with Cochlear Hearing Loss”** has been prepared under my supervision and guidance. It is also certified that this has not been submitted earlier in other University for the award of any Diploma or Degree.

Dr. Vijay Kumar Narne

Guide

Lecturer in Audiology,

Department of Audiology,

Mysore

All India Institute of Speech and Hearing,

May, 2012

Manasagangothri, Mysore- 570006

DECLARATION

This is to certify that this Master's dissertation entitled **“Perception of Spectrally Enhanced Speech through Companding in Individuals with Cochlear Hearing Loss”** is the result of my own study under the guidance of Dr. Vijay Kumar Narne, Lecturer in Audiology, Department of Audiology, All India Institute of Speech and Hearing, Mysore, and has not been submitted earlier in other University for the award of any Diploma or Degree.

Mysore

Register No. 10AUD009

May, 2012

ACKNOWLEDGEMENTS

People do not exist in isolation. Working together is what allows humans to achieve greatness. Many people have helped and supported me to complete this dissertation. While only my name appears at the top of this dissertation, a number of people deserve special mention for the help they provided me throughout this process.

First and foremost I would like to thank my guide Dr. Vijay Kumar Narne. I would like to thank him for all the advice, encouragement, help and everything that I learnt from him. Without him, this dissertation would not have been possible.

I would like to thank Dr. S. R. Savithri, Director, All India Institute of Speech and Hearing, Mysore, for permitting me to carry out this study.

I would like to thank the HOD, Department of Audiology, Dr. Animesh Barman, for permitting me to use the test equipments to conduct the study.

My special thanks to Asha mam, Rajalakshmi mam, Manjula mam, Animesh sir, Sandeep sir, Ajith sir, Sujit sir & Mamatha mam for imparting the valuable knowledge to me. Thank you for being my wonderful teachers.

My heartfelt thanks to my lovely family members – appa, amma, aiji, thatha & shivu for supporting me through all the good & bad times.

I would like to thank Jijo sir, Ganapathy Sir, Hemanth Sir, Arun Raj Sir, Anthony Sir, Sharath sir, Prashanth Sir & Sreela mam for helping me out with data collection. Ismail sir – he's more like an elder bro' to me than just a senior. Thanks for your great guidance & motivation sir!!!

I would like to thank my seniors -Srikar, Sruthi, Prabhash, Priyanjali, Niki, Anoop, Ashwini, Praween, Chaitra & Suma for their timely support.

I would like to thank all of my best buddies Arpitha, Deepa, Myz, Sanu, Sweta,Raheela, Priyanka, Kruthika, Maggie, Spoo, Apoo, Father of amplification-Saru,Sindhu, Amoo, Hemaraj, Dhana, Preeti, Deepika, Chandni,Sleeping beautyGiten, Mr. Jobish Extra Strong, Karate master Akshay, Divya, Merry, Zooboy, Sneha, Kaati ...& last but not the least my combined companding partner – Shachi!!!!

Thanks to my dearest juniors - Rekha, Scientist Swathi, Harshitha, Lakshmi, Guna, Kapali, Padmashree, Mala, Niharika, Janaki, Nikhil& specially Suppi Dottie for helping me in getting out from the adverse testing conditions... my best wishes to all of you..... Keep rocking!!!!

My heartfelt thanks to the library faculty – Shijit sir, Lokesh sir, Nanjundaswamy sir, Nandeesh Sir & Raju Sir for helping me in getting books & accessing to the Digital library.... & no words to thank www.google.com , for helping me to access important articles!!!!

I would like to thank all participants who had participated in this study.

I would like to thank all silent supporters whom I forgot to mention... thank you all.....

I specially thank this dissertation process itself, which helped me in improving my working potential from degraded to enhanced condition.

TABLE OF CONTENTS

Chapter No.	Title	Page No.
1	Introduction	1-3
2	Review of Literature	4 - 15
3	Method	16 - 20
4	Results and Discussion	21 - 32
5	Summary and Conclusion	33 - 35
6	References	36

LIST OF TABLES

Table No.	Title	Page No.
3.1	Demographic and audiological details of subjects with cochlear hearing loss	17
4.1	Paired 't' test results for sentence recognition threshold in noise (SNR-50) in normal hearing and cochlear hearing loss individuals	30

LIST OF FIGURES

Figure No.	Title	Page No.
2.1	Illustration of speech audiogram derived by Pascoe, 1980.	7
2.2	Illustrates the LPC spectrum of original and spectrally smeared vowel /u/.	9
3.1	Design of a single channel companding pathway	19
4.1	Mean and standard deviation (SD) of unprocessed Consonant recognition scores in normal hearing and cochlear hearing loss group.	22
4.2	Paired 't' test results in unprocessed and processed condition in normal hearing individuals.	26
4.3	Paired 't' test results in unprocessed and processed condition in cochlear hearing loss individuals.	27
4.4	Mean and standard deviation (SD) of unprocessed and processed sentence recognition threshold in noise (SNR-50) in normal hearing and cochlear hearing loss group.	29

CHAPTER 1

INTRODUCTION

The most common type of hearing loss is sensorineural hearing loss, which is usually associated with a dysfunction of the cochlea. People with cochlear hearing loss can understand speech reasonably well in one-to-one conversation in a quiet room, but they have great difficulty when there is background noise or reverberation, or when more than one person is talking (Plomp, 1978).

Reduced frequency selectivity is a well-documented abnormality that is associated with cochlear hearing loss, which can affect speech perception in noise (Tyler, Wood & Fernandes, 1982; Preminger & Wiley, 1985; Thibodeau & van Tasell, 1987). One mechanism by which impaired frequency selectivity could affect speech understanding in noise involves the perception of spectral shape. The recognition of speech sounds requires a determination of their spectral shapes, especially the locations of spectral prominence. Broader auditory filters associated with cochlear hearing loss, produce a more highly smoothed representation of the spectrum. If spectral features are not sufficiently prominent, they may be smoothed to such an extent that they become imperceptible. Leek, Dorman and Summerfield (1987) reported that the greater spectral contrast was required for vowel identification by hearing impaired than for normal hearing listeners. Adding a noise to speech fills the valleys between the spectral peaks and thereby reduces spectral prominence, resulting in poorer perception of speech in the presence of noise.

Thus, improving the intelligibility of speech in noise for individuals with cochlear hearing loss is one of the most difficult tasks faced by hearing aid manufacturers. There are currently a variety of tools available for this task, which

includes the application of digital signal processing to hearing aids. With appropriate prescription and fitting, a hearing aid can significantly improve speech recognition for an individual with hearing impairment in quiet and non-reverberant listening environment. However, this benefit is greatly reduced in presence of noise (Killion & Niquette, 2000). Hence, one of the challenges in providing amplification for the cochlear hearing loss individuals is to select the technology that will provide the maximum benefit in the presence of noise.

Need for the study

If reduced frequency selectivity impairs speech perception in noise for individuals with cochlear hearing loss, then enhancement of spectral contrasts might improve their performance. A number of spectral enhancement techniques have been tested using normal hearing and hearing-impaired (HI) listeners in order to improve their speech understanding in noise (Bunnell, 1990; Clarkson & Bahgat, 1991) and small to modest benefits have been obtained with the signal enhancement (Baer, Moore & Gatehouse, 1993). Recently, Turicchia and Sarpeshkar (2005) applied a frequency-specific companding strategy for spectral contrast enhancement and showed that it has the potential to improve speech performance in noise in cochlear implant (CI) users. Similarly, Bhattacharya and Zeng (2006) studied speech recognition in speech-shaped noise by cochlear implant users using companding strategy. They found significant improvement in the recognition of phonemes, consonants and sentences in noise. However, there is a dearth of studies done on investigating the perception of spectrally enhanced speech stimuli using companding strategy in individuals with cochlear hearing loss. Therefore, the present study was taken up.

Aim of the study

To evaluate the effect of spectral enhancement using companding strategy, on speech perception in quiet and noise among individuals with normal hearing and cochlear hearing loss.

Objectives of the study

- 1) To evaluate the unprocessed consonant recognition scores in individuals with normal hearing and cochlear hearing loss in (i) quiet, (ii) 15 dB SNR, (iii) 10 dB SNR and (iv) 0 dB SNR
- 2) To compare the unprocessed and processed (spectrally enhanced) consonant recognition scores in individuals with normal hearing and cochlear hearing loss in (i) quiet, (ii) 15 dB SNR, (iii) 10 dB SNR and (iv) 0 dB SNR
- 3) To compare the unprocessed and processed (spectrally enhanced) sentence recognition threshold in noise (SNR-50) in individuals with normal hearing and cochlear hearing loss

CHAPTER 2

REVIEW OF LITERATURE

Individuals with hearing loss usually complain difficulty understanding speech in noisy backgrounds, such as loud restaurants or crowded rooms. In general, hearing impaired listeners find very difficult to comprehend speech in such situations even if the speech information is loud enough to be above their threshold of audibility. Researchers have shown that hearing impaired subjects require a greater signal-to-noise (SNR) ratio than normally-hearing subjects in order to achieve the similar performance in speech-in-noise tests (Plomp & Mimpen, 1979; Dubno, Dirks & Morgan, 1984).

2.1 Cochlear hearing loss

Cochlear hearing loss involves damage to the OHCs and IHCs; the stereocilia may be distorted or destroyed, or entire hair cells may die. The OHCs are generally more vulnerable to damage than the IHCs. When OHCs are damaged, the active mechanism tends to be reduced in effectiveness or lost altogether. The function of the OHCs can also be adversely affected by malfunctioning of the stria vascularis (Schmiedt, 1996). As a result, several changes occur: the sensitivity to weak sounds is reduced; so sounds need to be more intense to produce a given magnitude of response on the BM, the tuning curves on the BM become much more broadly tuned and all of the frequency-selective nonlinear effects weaken or disappear altogether (Kiang, Moxon & Levine, 1970). As a result of the damaged cochlea, many kinds of perceptual consequences can also arise this includes impaired frequency and temporal resolution. Reduced frequency resolution results in impaired discrimination of formants and vowels, while masking of syllables occurs with reduced temporal resolution which in turn can affect speech communication (Schorn & Zwicker, 1990).

2.2 Speech perception in individuals with Cochlear hearing loss (CHL)

2.2.1 Speech Perception in Quiet

Listeners with CHL frequently complain of difficulty in speech understanding. The extent and nature of the difficulty depends partly on the severity of the hearing loss. Individuals with mild or moderate CHL have difficulty when more than one person is talking at once, or when background noise or reverberation is present, but can usually understand speech reasonably well in a quiet room with only one person talking. Individuals with severe or profound CHL have difficulties even when listening to a single talker in a quiet room, and they generally have severe problems when listening in background noise. Hence, they rely heavily on lip reading or speech reading and on the use of context for understand speech.

There has been considerable controversy in the literature regarding the reasons for difficulties in understanding speech. One group of researchers has argued that the difficulties arise mainly from reduced audibility. That is pure-tone thresholds are higher than normal, so the amount by which speech is above threshold, and/or the proportion of the speech spectrum which is above threshold, are both less than for normal listeners (Humes, Dirks & Kincaid, 1987; Zurek & Delhorne, 1987; Lee & Humes, 1993). In other words, it is argued that the difficulties occur mainly because part of the speech cannot be heard at all. Figure 2.1 shows the pictorial depiction of effect of audibility on available speech spectrum. It also shows an example of available speech spectrum for mild, moderate and severe degree of hearing loss. It can be clearly seen that for severe hearing loss, most of the speech are not audible, whereas for mild only 25 % of speech information is not available. From the above it is understood that audibility is one of important factor for speech understanding.

Whereas, other group of researchers (Plomp, 1978, 1986; Glasberg & Moore, 1989) have argued that the difficulty in understanding speech arises at least partly from a reduced ability to discriminate sounds which are well above the absolute threshold. According to this point of view, even if speech is amplified so that it is audible, the cochlear hearing impaired person will still have problems in understanding speech. The literature has consistently demonstrated that, for mild losses, audibility is the single most important factor. For the degree of hearing loss higher than mild, poor discrimination of supra-threshold (audible) stimuli is also one of major important factors.

2.2.2 Speech Perception in noise

CHL listeners have greater difficulty in understanding speech in noise when compared to normal hearing listeners. This is often quantified using two measures, one estimating the speech perception scores at different signal to noise ratios and second one, assessing speech-to-noise ratio required to achieve a certain degree of intelligibility, such as 50% correct. This ratio is called the speech reception threshold (SRT) and it is usually expressed in dB. The higher the SRT, the poorer is performance.

a. Reduced audibility

Audibility is crucial factor for speech intelligibility i.e., if part of the speech spectrum is below the absolute threshold or is masked by background sound, then information is lost, and intelligibility will suffer to some extent (as depicted in figure 2.1). In spatially separated background noise conditions (typically the case in everyday life) “head shadow” effect often lead to an improved speech-to-background ratio at one ear and these effects are greatest at high frequencies. A loss of ability to hear high

frequencies may drastically reduce the ability to take advantage of head shadow effects (Bronkhorst and Plomp, 1989).

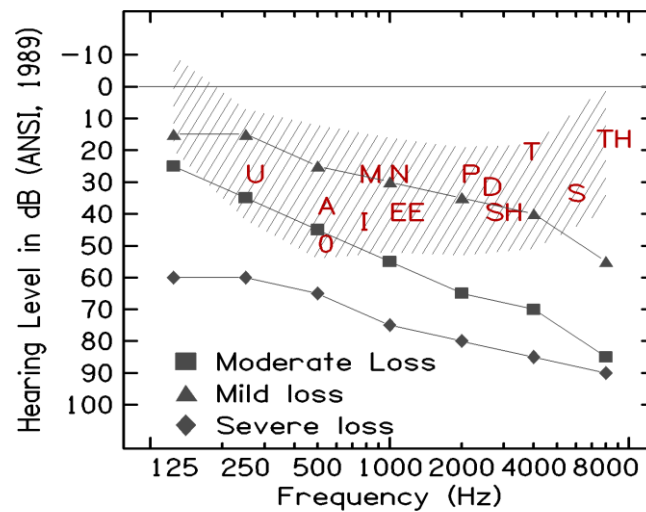

Figure 2.1: Illustration of speech audiogram derived by Pascoe, 1980. The hashed line represents the speech spectrum in dB HL, for a speech signal having an overall sound pressure level of 65 dB. Orthographic representations of various speech sounds have been superimposed on the speech audiogram to illustrate their relative amplitudes and frequency content.

The articulation index (AI) provides a way of quantifying the effect of audibility on speech intelligibility. Several researchers have examined the question of whether the AI can be used to predict speech intelligibility for hearing-impaired listeners in noise. While some have reported accurate predictions using the AI (Lee & Humes, 1993), most studies have shown that speech intelligibility is worse than would be predicted by the AI (Pavlovic, 1984; Ching, Dillon & Byrne, 1998; Hogan & Turner, 1998), especially for listeners with moderate or severe losses. Thus, factors other than audibility must contribute to the difficulties experienced by the hearing impaired. Some possible factors are considered next.

Glasberg and Moore (1989) measured SRT in six listeners with bilateral CHL in quiet and at two levels of noise (65 dB and 75 dB SPL). Most subjects had absolute thresholds for their impaired ears in the range 40–60 dB HL. The SRTs were higher for

the impaired than for the normal ears, both in quiet and in noise. Taking the results for all ears together, the SRT in quiet was highly correlated with the mean absolute threshold at 0.5, 1 and 2 kHz ($r = 0.96$, $p < 0.001$), whereas in noise the correlation was $r = 0.56$ ($p < 0.01$). The correlation noted in noise was lower than those found in quiet. This indicates that, for noise levels sufficient to raise the SRT well above that measured in quiet, a significant proportion of the variance in the SRTs was not accounted for by variations in absolute threshold.

Different approaches have been employed to study the effects of audibility on speech perception. One is frequency-dependent attenuation (filtering) so as to imitate the effect of a hearing loss on audibility. If audibility is the main cause of difficulty in speech understanding experienced by the hearing-impaired subject, then performance should be similar for the hearing-impaired subject listening to unfiltered speech and normally hearing subjects listening to filtered speech. There were only few studies which were conducted in quiet. They demonstrate that large proportion of variability in performance could be explained by audibility (Fabry & van Tasell, 1986). There do not seem to have been any studies of this type examining the speech intelligibility in noise. Thus, it is not known whether selective filtering to match the audibility of the speech in noise for normal and hearing-impaired listeners would produce equal performance for the two groups.

Overall, the aforementioned reports suggest that one or more factors other than audibility contribute to the difficulties of speech perception in noise experienced by those with moderate or greater cochlear losses. In other words, the difficulties arise partly from abnormalities in the perception of sounds that are above the threshold of audibility. For those with mild losses, audibility is probably the dominant factor.

b. Frequency selectivity

Frequency selectivity is the ability to re-solve the individual frequency components in a complex signals. This depends largely on the filtering that takes place in the cochlea (i.e. Cochlea can be described as containing serious of band pass filters) (Moore, 1997). The output of the filters, plotted as a function of center frequency is called the excitation pattern, and it resembles a blurred version of the spectrum of the input signal (Moore, 1997). CHL listeners usually have auditory filters that are broader than normal (Glasberg & Moore, 1986; Tyler, Wood & Fernandes, 1982). This means that their ability to resolve the spectral components of speech sounds, and to separate components of speech from background noise, is reduced. Simulation studies of reduced frequency selectivity, implemented by “smearing” of the short-term spectrum, strongly suggest that it may be one of the contributing factor for impaired speech perception in noise (Baer & Moore, 1993, 1994; Nejime & Moore, 1997).

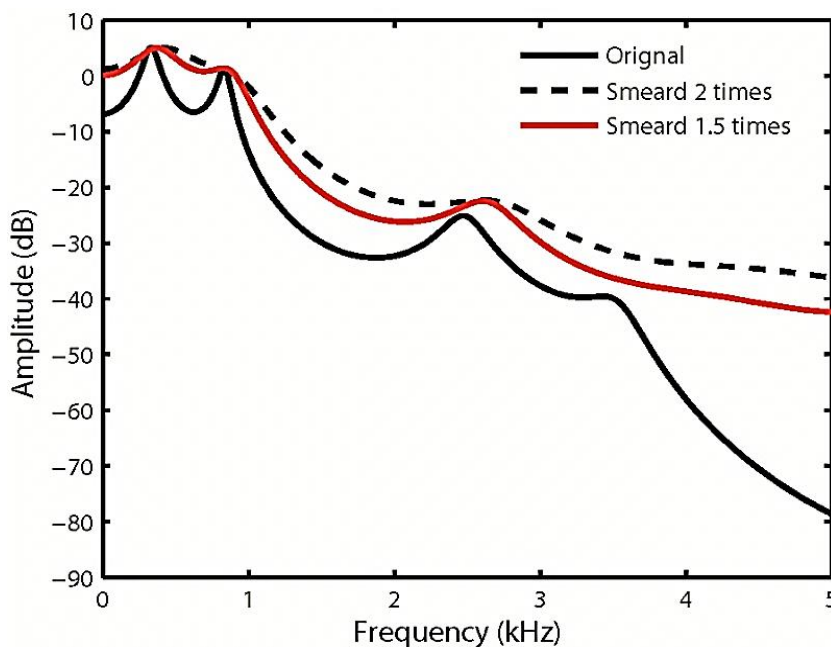

Figure 2.2: Illustrates the LPC spectrum of original and spectrally smeared vowel /u/. Spectral smearing was performed using STFT (Short Fourier Transform) as described by Moore and Glasberg (1993).

One mechanism by which impaired frequency selectivity could affect the identification of speech in noise involves the perception of spectral shape. Broader auditory filters produce a more highly smoothed representation of the spectrum (the excitation pattern) than normal auditory filters. Figure below depicts the original and smeared representation of the vowel /u/ for two different amount broadening of auditory filters. It can be readily observed abnormal increasing bandwidth of the auditory filter, smoothen the spectrum, i.e., the representations of the formant frequencies were reduced this causes imperceptions of formants. Adding a noise background to speech, fills in the valleys between the spectral peaks and thus reduces their prominence, exacerbating the problem of perceiving them for people with broadened auditory filters.

Ching, Dillon and Byrne (1997) attempted to determine the importance of psycho-acoustical factors for speech recognition after the effects of audibility had been taken into account. To do this, they presented speech in quiet over a wide range of levels and under various conditions of filtering. For each level and condition, the SII was calculated and the number of key words in sentences that were correctly identified was measured. Twenty-two hearing-impaired subjects were tested. The speech scores for these subjects were expressed as deviations from the values predicted from the SII. These deviations represent the extent to which speech scores are better or worse than expected for a given amount of audibility of the speech. The deviations of the speech scores from the predicted values at high SLs were significantly correlated with a measure of frequency selectivity at 2 kHz (obtained using a notched-noise masker).

Baer and Moore (1993) measured the intelligibility of speech in quiet and in speech-shaped noise. Normally hearing listeners listened to sentence material that had been processed to simulate varying degrees of loss of frequency selectivity as described by Moore, Glasberg and Simpson, (1992). The intelligibility of speech in quiet was

hardly affected by spectral smearing, even for smearing that simulated auditory filters six times broader than normal. The intelligibility of speech in noise was adversely affected by the smearing, especially for large degrees of smearing and at a low speech-to-noise ratio. Further, Baer and Moore (1994) measured perception of smeared speech in steady background and a single competing talker background; they demonstrated that speech is more affected in single talker background than steady background.

In summary, the results of experiments on spectral smearing suggest that reduced frequency selectivity does contribute significantly to the difficulties experienced by people with CHL in understanding speech in the presence of back- ground sounds.

c. Loudness recruitment

Most people with CHL show a phenomenon called loudness recruitment (Fowler, 1936). That is abnormal growth of loudness for signals above threshold. Loudness recruitment may affect speech intelligibility in quiet and noise. Firstly, recruitment reduces the dynamic range (the range between the absolute threshold and the highest comfortable level). In fluctuating background sound, this may affect the ability to “fallow in the dips”. If the peaks in the background are amplified to the highest comfortable level, the level of target speech in the through may be close to or below the absolute threshold. Finally, loudness recruitment causes abnormal growth of loudness to high intensity components of speech signal which may lead to a distorted loudness relationship among the components of speech sounds; that is relative loudness of the components may be distorted.

To study the effect of only elevated threshold and loudness recruitment. Moore and Glasberg (1993) measured speech perception in quiet and noise background by simulating thresholds elevation and loudness recruitment and presenting test material to

normal hearing listeners. For speech in quiet, simulation proceeded 'as expected' reduction in ability to understand speech, whereas speech presented at high intensity levels yielded high intelligibility for all levels of simulation. For speech in single talker background, simulation of loudness recruitment and threshold elevation yielded substantial decrement, 13 dB higher than normal, in performance. In speech shaped noise (continuous) condition speech to noise ratio has to be 6 dB higher than normal to achieve comparable performance with normal hearing listeners (Moore, 2007).

The difference between steady and fluctuating background can be understood in following ways. Normal hearing listeners can take advantage of spectral and temporal in single talker background. Hence the speech to noise ratio required to achieve given level performance is markedly lower than when the background is steady state noise. Dip listening requires wide dynamic range, listeners with CHL or simulated condition has reduced dynamic range, Which causes intense parts of speech be comfortable loud and weaker part of speech may be in audible. Hence, listeners with CHL can't listen in dips as effectively has normal hearing listeners.

Comparison of results of simulation suggests that threshold elevation, reduced frequency selectivity and loudness recruitment probably largely sufficient to account for the difficulties of speech perception experienced by people with CHL.

2.3 Strategies to improve speech perception in noise in individuals with Cochlear hearing loss

Ideally, a hearing aid should compensate for the reduced frequency resolution for cochlear hearing loss individuals in order to improve their speech understanding in noise. However, Plomp (1978) described two components of sensorineural hearing loss: (a) attenuation and (b) distortion. Hearing aids compensate for the attenuation factor but

do not overcome the distortion component caused by reduced frequency resolution. Therefore, several spectral enhancement techniques that have attempted to compensate for poorer spectral resolution in improving intelligibility in noise. Thus, if a hearing aid has to improve speech understanding in noise beyond just amplifying the speech signal, envelop of the signal must also be somehow enhanced.

Several researchers have attempted to improve speech intelligibility for the hearing impaired by enhancement of spectral features. Results from these studies have evoked two schools of thoughts, one group believe that there is significant improvement in perception whereas the other group have found no benefit. Simpson, Moore and Glasberg (1990) describe a method of digital signal processing of speech in noise so as to increase differences in level between peaks and valleys in the spectrum. The processing involves manipulation of the short-term spectrum of the speech in noise using the overlap-add technique. They measured the intelligibility of sentences in speech-shaped noise in subjects with moderate cochlear hearing loss. The results revealed small but statistically significant improvements in speech intelligibility for the processed speech.

Baer, Moore and Gatehouse (1993) varied the amount of enhancement and found that large amounts of enhancement produced decreases in the intelligibility of speech in noise. Performance for moderate degrees of enhancement was generally similar to that for the unprocessed condition. Researchers believe that this decline in performance could be due to lack of sufficient experience by the subjects to the processed speech.

Franck et al. (1999) investigated both the separate and combined effects on speech perception of compensation of the “reduced dynamic range” by “compression” and compensation of the “reduced frequency resolution” by “spectral enhancement”. They compared the effects of spectrally enhanced processed speech with unprocessed speech. They found better scores for vowels in spectrally enhanced signals while less for consonants. The researcher reported that the reason for the lack of its success is not clear, and he gave two possibilities as it may be that spectral enhancement is a theoretically flawed strategy or that the implementation of spectral enhancement has been done ineffectively.

To summarize, results on the effect of spectral enhancement are equivocal. Some studies have shown no benefit, whereas others have shown modest benefits. However, the increased intelligibility of speech in noise can vary depending on the strategy implemented by the researchers. Hence, an effective implementation of speech enhancement strategy might lead to better speech understanding in noise by hearing impaired individuals.

2.4 Implementation of Companding strategy for spectral enhancement

Turicchia and Sarpeshkar (2005) have proposed companding strategy for spectral enhancement, based on relatively broadband compression followed by more frequency-selective expansion. This compressing-and-expanding, companding approach leads to certain properties shared by the peripheral auditory system. In particular, it can produce a suppression of the response to one tone by the presence of another more intense-tone at a nearby frequency, an effect known as two-tone suppression. At a more global level, the companding scheme can lead to the enhancement of spectral peaks in a stimulus, relative to nearby spectral valleys.

The companding strategy uses a noncoupled filter bank and compression-expansion blocks. Every channel in the companding architecture has a relatively broad prefilter, a compression block, a relatively narrowband postfilter and an expansion block. The prefilter and postfilter in each channel have the same center frequency. The pre-filter and post-filter banks have logarithmically spaced center frequencies that span the desired spectral range. Finally, the channel outputs of this nonlinear filter bank are summed to generate an output with enhanced spectral peaks.

Oxenham, Simonson, Turicchia, and Sarpeshkar (2006) tested a time-domain spectral enhancement algorithm that was proposed by Turicchia and Sarpeshkar (2005). Normal-hearing listeners were tested in their ability to recognize sentences processed through a noise-excited envelope vocoder that simulates aspects of cochlear-implant processing. The sentences were presented in a steady background noise at signal-to-noise ratios of 0, 3, and 6 dB. Using an eight-channel envelope vocoder, companding produced small but significant improvements in speech reception. Similar findings have been reported by Bhattacharya and Zeng (2007) wherein scores improved by about 21.3 % at 0 dB SNR for vowel recognition, 12.1 % at 5 dB SNR for consonant recognition and 17.7 % at 5 dB SNR for sentence recognition in cochlear implant users. These results have shown that companding strategy can be beneficial in CI users in adverse listening conditions. However, these kinds of studies are not done in individuals with cochlear hearing loss.

Hence, the current study was taken up to assess the benefit of spectral enhancement of signal using companding strategy in individuals with cochlear hearing loss. It will be interesting and relevant to understand the effect of spectral enhancement using companding strategy on the perception of consonants and sentences recognition threshold in noise for individuals with normal hearing and cochlear hearing loss.

CHAPTER 3

METHOD

The present study was conducted to assess the benefit of the spectral enhancement of speech using companding strategy in individuals with cochlear hearing loss.

3.1 Subjects

Two groups of subjects participated in the present study. Both the groups consisted of 10 male and 10 female subjects. All of them were native speakers of Kannada.

3.1.1 Group I

Group-I included 20 subjects with normal hearing in the age range of 19 to 48 years, with the mean age of 32. They had hearing sensitivity less than or equal to 15 dB HL at octave frequencies between 250 Hz and 8000 Hz. All of them had 'A' type tympanogram with present ipsi and contralateral acoustic reflex thresholds, normal auditory brainstem responses and presence of otoacoustic emissions. The subjects had no history of otological and neurological problems. They had SPIN scores greater than 60% at 0 dB SNR.

3.1.2 Group II

Group-II included 20 subjects with acquired cochlear hearing loss in the age range of 18 to 48 years, with the mean age of 34. They were diagnosed as having cochlear hearing loss at the department of audiology, All India Institute of Speech and Hearing, Mysore. The degree of hearing loss ranges from mild to moderately severe hearing loss. Detailed demographic and audiological findings are shown in table 3.1.

Table 3.1: *Demographic and audiological details of subjects with cochlear hearing loss*

Subject (Test ear)	Age (yrs)/ Sex	PTA (dB HL)	SIS (%)	Tympanometry (type)	Acoustic reflexes	OAE
S1 (L)	35/M	65	96	“A”	Absent	absent
S2 (L)	45/F	45	92	“A”	Present	absent
S3 (L)	44/M	60	92	“A”	Present	absent
S4 (R)	45/M	55	96	“A”	Present	absent
S5 (R)	40/F	40	88	“A”	Present	absent
S6 (L)	36/M	40	100	“A”	Present	absent
S7 (R)	35/F	28.3	96	“A”	Present	absent
S8 (R)	18/M	65	90	“A”	Present	absent
S9 (L)	39/M	58.3	80	“A”	Present	absent
S10 (R)	30/F	53.3	92	“A”	Present	absent
S11 (R)	48/F	53.3	100	“A”	Present	absent
S12 (R)	20/F	60	84	“A”	Present	absent
S13 (L)	28/M	65	88	“A”	Present	absent
S14 (R)	21/F	55	80	“A”	Present	absent
S15 (R)	36/M	26.6	96	“A”	Present	Absent
S16 (R)	47/M	60	96	“A”	Present	Absent
S17 (R)	48/M	30	100	“A”	Present	absent
S18 (L)	30/F	41.6	100	“A”	Present	absent
S19 (L)	20/F	38.3	96	“A”	Present	absent
S20 (L)	22/F	45	88	“A”	Present	absent

3.2 Instrumentation

The following instruments were used in the present study

- A calibrated two channel diagnostic audiometer, (GSI - 61) with TDH-39 earphones and Radio ear B-71 bone vibrator
- Calibrated GSI-Tympstar (Grason-Stadler Incorporation, USA) clinical immittance meter
- ILO 292 DPEcho port system
- Intelligent Hearing Systems (IHS smart EP windows USB version 3.91)
- MATLAB-7 (Language of Technical computing, USA)
- Toshiba Satellite L645 laptop (Realtek sound card) and AHUJA AUD-101XLR dynamic unidirectional microphone

3.3 Test environment

All the tests were conducted in an air conditioned, double room situation where the ambient noise levels were within permissible limits.

3.4 Stimulus

3.4.1. Consonants

Twenty consonants /p, b, t, d, k, g, ʈ, ɖ, m, n, ɳ, ɟ, s, ʃ, j, v, r, l, ɭ, h/ in the context of the vowel /a/ was used. They were spoken by a native Kannada female speaker (language spoken in southern part of India) and were digitally recorded in an acoustically treated room, on a data acquisition system using 44.1 kHz sampling frequency with a 16-bit analog to digital converter. While recording the microphone was placed at a distance of 15cm from the lips of the speaker. The recorded stimuli were root mean square normalized to maintain equal loudness and Goodness test* was performed to assess quality of recording. In the experiments involving background noise, each consonant was mixed with a speech spectrum shaped noise at SNRs of 0, 10 and 15 dB.

3.4.2. Sentence

The speech stimuli were sentences in Kannada, developed by Avinash, Raksha and Kumar (2008). There were a total of 10 lists, each list consisting of 7 sentences. Each sentence carried 4 to 5 target words. All the sentence lists were phonetically balanced and were equally difficult. The seven sentences each list were mixed with speech spectrum shaped noise at different SNR ranging from +20 dB to -10 dB SNR in 5 dB step-size.

*Goodness test for the recorded material was carried out by presenting the stimuli to 10 individuals with normal hearing. All the normal hearing participants obtained 100% score indicating that speech material was highly intelligible.

Signal processing strategy

The spectral enhancement using companding architecture was implemented in MATLAB. The details of the implementation of the companding algorithm are presented in Turicchia and Sarpeshkar (2005). The companding architecture divides the input signal into 40 frequency channels by a bank of relatively broad band-pass filters. Figure 3.1 shows the design of a single channel companding pathway. Each channel consists of broad pre-filter, a compression block, a relatively narrow-band post-filter and an expansion block. The time constant of the envelope detector governs the dynamics of the compression or expansion. The extent of compression within each channel depended on the output of ED and compression index (n_1). Further, the compressed signal was passed through a relatively narrow band-pass filter before being expanded. The gain of the expansion block depended on the corresponding ED output and the ratio n_2/n_1 . The outputs from all the channels were summed to obtain the processed signal.

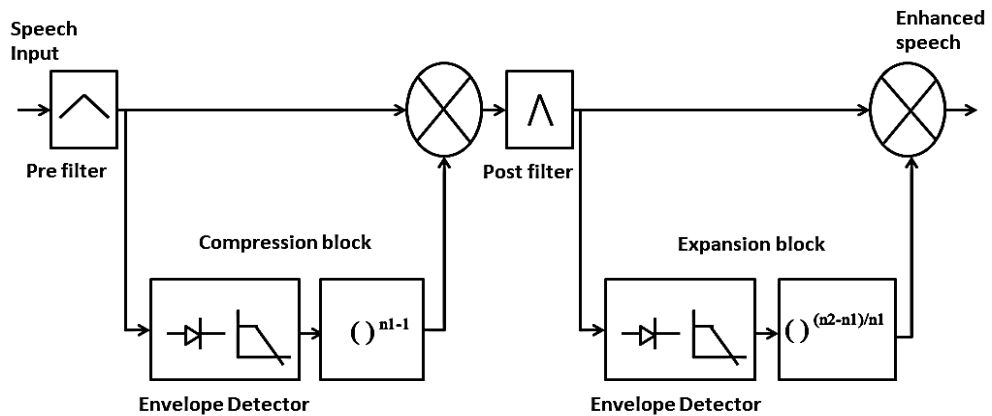

Figure 3.1: Design of a single channel companding pathway

Here, 40 channels logarithmically spaced between 100 and 10000 Hz with $n_1 = 0.3$ and $n_2 = 1$ was used. Both consonants and sentences were processed through this companding strategy, to increase the spectral contrast (quiet and different SNR conditions).

3.5 Procedure

Speech recognition experiments were done on individuals with normal hearing and cochlear hearing loss. The output from the laptop was routed to the tape input/auxiliary input of the audiometer (GSI-61). Prior to the presentation of the speech stimuli, a 1 kHz calibration tone was played to set the VU meter deflection to '0'. The test stimulus was presented to the subjects at their most comfortable level through the TDH 39 headphones.

Consonant recognition:

In consonant recognition tests, twenty VCV stimuli were presented. They were presented across four different listening conditions (quiet, 15 dB, 10 dB and 0 dB SNR) in unprocessed and processed condition. Subjects were instructed to repeat the consonant that was heard.

Speech recognition threshold in noise:

The participants were instructed to listen to the sentence and repeat aloud as many of the words as possible. The experimenter noted the number of words that were correctly repeated by the participant. Stimuli were presented at comfortable. The starting SNR was +20 dB is lowered by 5 dB till the level at which two of the four or three of the five words of the sentence are repeated correctly. The SNR, at which two of four or three of five words repeated correctly, is considered as SNR-50.

The data collected were tabulated and analyses were carried on to examine the objectives of the present study. The results obtained are discussed in the next chapter.

CHAPTER 4

RESULTS AND DISCUSSION

The present study was carried out to investigate the benefit of spectral enhancement using companding strategy in quiet and noise for individuals with normal hearing and cochlear hearing loss. This was examined for consonant identification and sentence recognition threshold in noise (SNR-50). The data obtained was tabulated and analysed using Statistical Package for Social Sciences (version 16.0).

4.1 Consonant recognition scores

4.1.1 Consonant recognition in unprocessed condition

Consonant recognition scores were obtained in unprocessed condition among individuals with normal hearing and cochlear hearing loss. Individuals with normal hearing achieved 95 – 100 % consonant recognition scores in the quiet condition than in the presence of noise. Across different SNRs, maximum scores were obtained at 15 dB SNR, followed by 10 dB and 0 dB SNR. Performance reduced with the decrease in the SNR. Individuals with cochlear hearing loss obtained relatively poorer scores than those with normal hearing as shown in figure 4.1. In quiet condition, identification scores obtained were 78 % and at 0 dB SNR, scores dropped to 20 %.

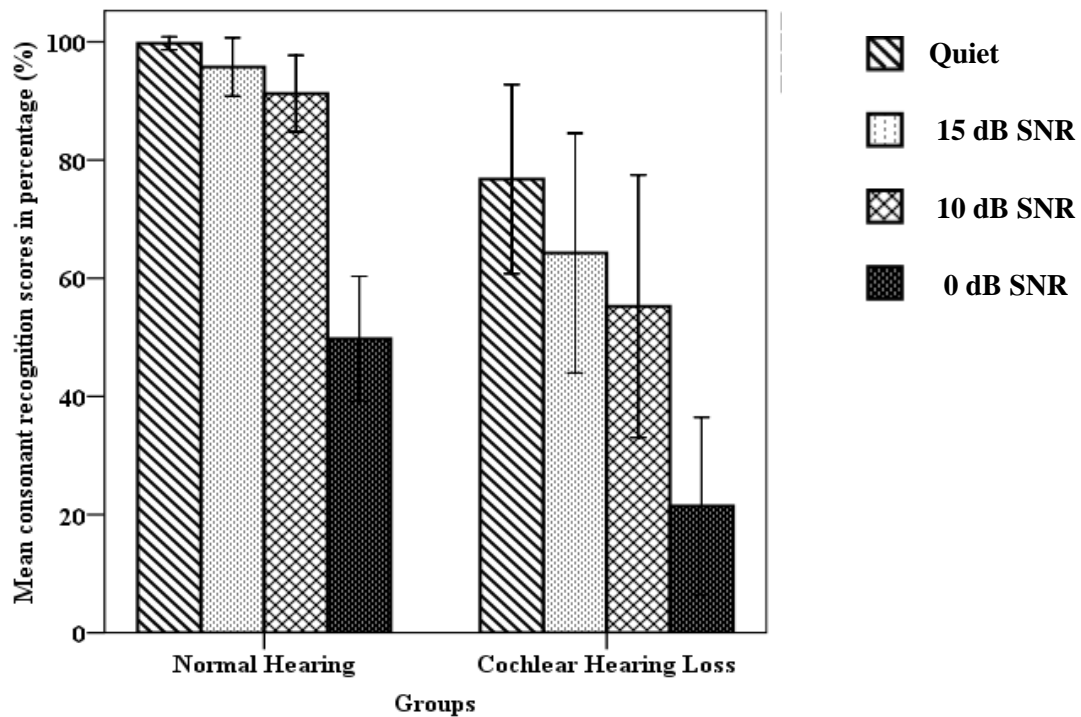

Figure 4.1: Mean and standard deviation (SD) of unprocessed Consonant recognition scores in normal hearing and cochlear hearing loss group. Error bars indicate SD.

Repeated measure ANOVA was performed to assess the difference in unprocessed consonant recognition scores across the four listening conditions (quiet, 15 dB, 10 dB and 0 dB SNR) within individuals with normal hearing and cochlear hearing loss separately. Analysis revealed a significant difference in individuals with normal hearing [$F(3, 57) = 300.03, P < 0.001$] and cochlear hearing loss [$F(3, 57) = 122.17, P < 0.001$]. For both the groups, there was significant difference between consonant recognition scores in the four listening conditions. The pairwise comparison was performed using Bonferroni test in both the groups. Results showed that there was significant difference across the different listening conditions for both the groups ($p < 0.05$).

Further, MANOVA was done to compare the unprocessed consonant recognition scores between individuals with normal hearing and cochlear hearing loss across all the four listening conditions. Results showed a significant difference in consonant recognition scores between the groups in quiet [$F(1, 38) = 43.56, p < 0.05$], 15 dB SNR [$F(1,38) = 45.55, p < 0.05$], 10 dB SNR [$F(1,38) = 48.43, p < 0.05$] and 0 dB SNR [$F(1,38) = 47.54, p < 0.05$].

From the results of present study, it can be noted the normal hearing individuals obtained 100 % consonant recognition scores in quiet condition. However as the SNR decreased, there was a minimal reduction in 15 dB and 10 dB SNR, whereas at 0 dB SNR scores reduced drastically. In individuals with cochlear hearing loss, poorer scores were obtained in quiet condition compared to normal hearing individuals. Also as the SNR reduced, there was a drastic decrease in the scores for those with cochlear hearing loss. This reduction in scores was greater than the normal hearing individuals.

In quiet condition, cochlear hearing loss subject's scores were 20 % lower than the normal hearing listeners. The lower consonant recognition scores in cochlear hearing loss individuals may be due to the reduced audibility, reduced frequency selectivity or loudness recruitment. Reduced audibility may not be the major factor, because, the recognition scores were obtained at comfortable level in all the listeners. Many investigators demonstrated no significant correlation between identification scores and frequency selectivity (Dubno & Dirks, 1982; Dubno & Schaefer, 1992). However, loudness recruitment may be one of the major causes which leads to reduced dynamic range and changes the amplitude variations in the speech signal. These changes involve increase in the amplitude of vowel more significantly than the consonants which increase the upward spread of masking. This leads to masking of

consonantal portion, and hence consonant recognition is affected in individuals with cochlear hearing loss.

In noisy condition, consonant recognition scores in normal hearing individuals reduced more significantly at 0 dB SNR by about 40 %, whereas in cochlear hearing loss scores dropped to almost 16 % at 0 dB SNR. The precise reason for low scores is not known. Some of the possible reasons could be reduced frequency selectivity and loudness recruitment. Investigators have demonstrated that individuals with cochlear hearing loss have auditory filters that are broader than normal (Glasberg & Moore, 1986; Tyler, Wood & Fernandes, 1982). This means that, the ability to resolve the spectral components of speech sounds and to separate the components of speech from background noise is reduced. One mechanism by which impaired frequency selectivity could affect speech understanding in noise involves the perception of spectral shape. Broader auditory filters produce a more highly smoothed representation of the spectrum (the excitation pattern) than the normal auditory filter. Further, smoothed spectrum results in reduced formant frequency representation which causes imperceptions of the formants. Adding a noise background to speech, fills the valleys between the spectral peaks and thus reduces spectral prominence, exacerbating the problem of perceiving them for people with broadened auditory filter.

Another reason is that, many recent investigators have demonstrated that cochlear hearing loss listeners depend more on envelop of speech signal than the fine structure and adding a noise would significantly alter the envelop of the signal that is., reducing the modulation depth and distorting the modulation. Because of the above mentioned reasons, individuals with cochlear hearing loss have more significant problem than those with normal hearing.

To summarize, individuals with cochlear hearing loss perform poorly in noise which may be due to reduced frequency selectivity, loudness recruitment and impaired ability in extracting envelop of speech signal in noisy condition.

4.1.2 Consonant recognition in processed condition

Consonant recognition scores were obtained for normal hearing and cochlear hearing loss in both unprocessed and processed condition. Individuals with normal hearing obtained almost similar scores in quiet, 15 dB and 10 dB SNR in both unprocessed and processed condition, whereas scores improved by 12 % at 0 dB SNR in processed condition. In cochlear hearing loss individuals, improvement in processed condition was about 4.5 % at 15 dB, 5.25 % at 10 dB SNR and 18.75 % at 0 dB SNR. Both the groups obtained higher scores in processed than unprocessed condition as shown in figure 4.2 and 4.3. In addition, individuals with cochlear hearing loss obtained lesser scores than those with normal hearing.

Repeated measure ANOVA was done to compare the unprocessed and processed consonant recognition scores across listening conditions (quiet, 15 dB, 10 dB and 0 dB SNR) in normal hearing individuals. Further, results showed significant difference across different listening conditions in unprocessed [$F(3, 57) = 300.032, p < 0.05$] and processed [$F(3, 57) = 120.159, p < 0.05$]. Further, paired 't' test was performed to compare unprocessed and processed consonant recognition scores across each of the listening conditions (quiet, 15 dB, 10 dB and 0 dB SNR). Results revealed significant difference in the performance of normal hearing group in unprocessed and processed condition at 0 dB SNR only. Processed condition had an average of 12 % greater improvement at 0 dB SNR ($p < 0.05$) over unprocessed condition. However, no

significant difference was obtained in quiet ($p = 0.33$), 15 dB ($p = 0.57$) and 10 dB SNR ($p = 0.67$).

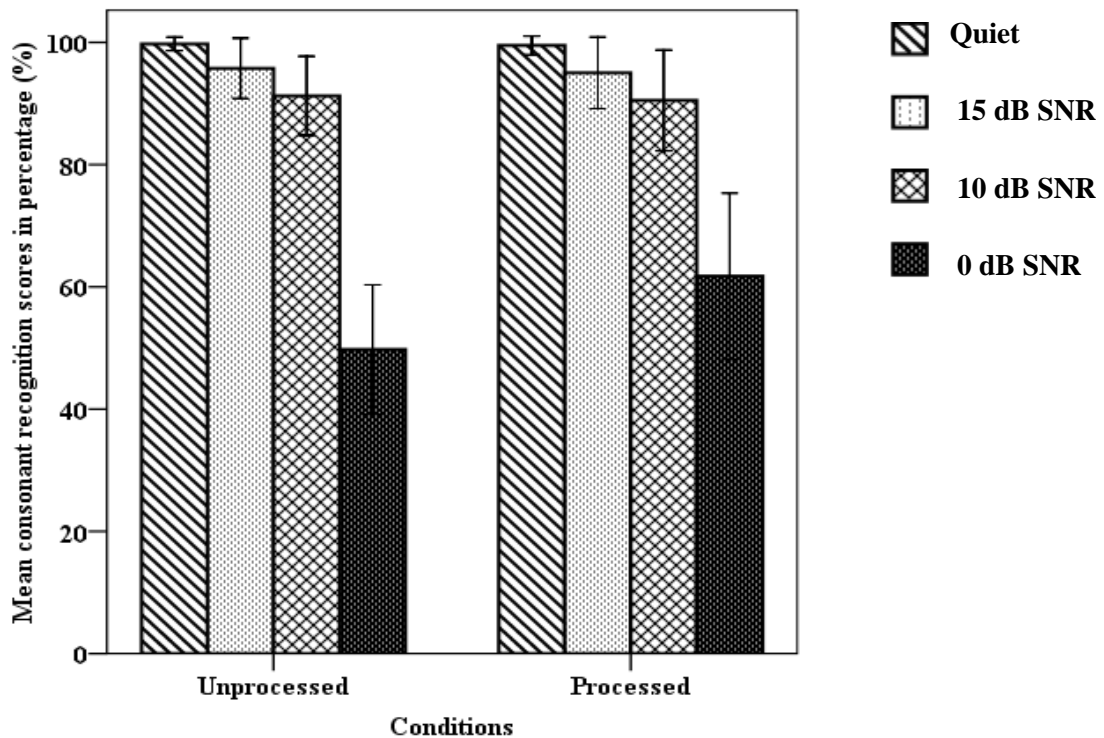

Figure 4.2: Paired ‘t’ test results in unprocessed and processed condition in normal hearing individuals. Error bars indicate SD.

To compare the unprocessed and processed consonant recognition scores across listening conditions (quiet, 15 dB, 10 dB and 0 dB SNR) in cochlear hearing loss individuals, repeated measure ANOVA was carried out. Results showed significant difference across different listening conditions in unprocessed [$F(3, 57) = 122.178, p < 0.05$] and processed [$F(3, 57) = 84.548, p < 0.05$].

Among cochlear hearing loss individuals, paired ‘t’ test results revealed significant difference in unprocessed and processed consonant recognition scores at 15 dB, 10 dB and 0 dB SNR except quiet condition (figure 4.3). Maximum improvement was seen at 0 dB SNR (18.75 %) than 10 dB SNR (5.25 %) followed by 15 dB SNR (4.5 %) in processed over unprocessed condition.

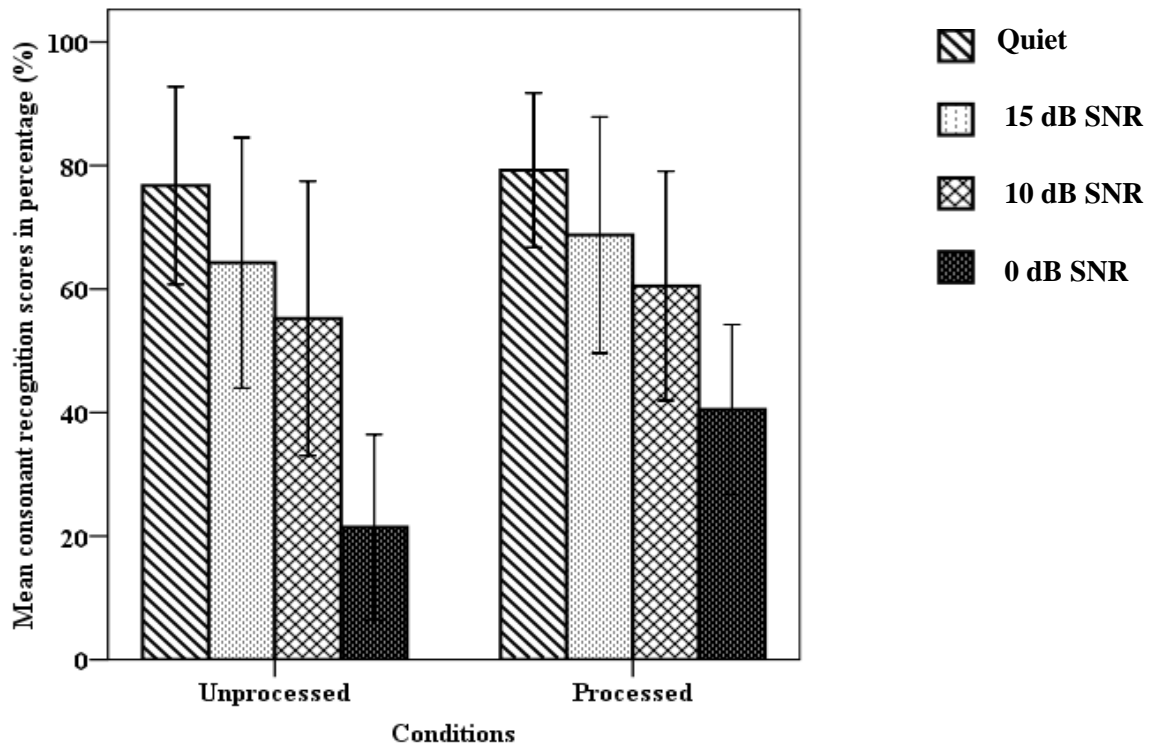

Figure 4.3: Paired ‘t’ test results in unprocessed and processed condition in cochlear hearing loss individuals. Error bars indicate SD.

MANOVA was done to compare the consonant recognition scores between normal hearing and cochlear hearing loss individuals across different listening conditions (quiet, 15 dB, 10 dB and 0 dB SNR). Results revealed a significant difference in consonant recognition scores between the groups in quiet [$F(1, 38) = 51.790, p < 0.05$], 15 dB SNR [$F(1, 38) = 34.481, p < 0.05$], 10 dB SNR [$F(1, 38) = 43.622, p < 0.05$] and 0 dB SNR [$F(1, 38) = 24.270, p < 0.05$].

In the present study, spectral enhancement using companding strategy improved the consonant recognition scores in noise for individuals with normal hearing and cochlear hearing loss. To our knowledge, there are no studies that have utilized companding strategy in cochlear hearing loss individuals. Many studies which have used different other strategies to enhance spectral contrast have shown improvement in noise with enhancement (Baer, Moore & Gatehouse, 1993; Yang, Luo & Nehorai,

2003; Frank et al, 1999). However, the above mentioned studies cannot be compared due to the larger differences in the signal enhancing strategies and rationale behind these strategies. The improvement with companding strategy to be two-folded: (i) reduced frequency selectivity affects the perception of the consonant in the presence of noise by reducing its spectral contrast. Increasing the spectral contrast of the consonant using spectral enhancement, thereby will compensate for reduced frequency selectivity and reduced spectral contrast (Baer, Moore & Gatehouse, 1993; Watkins & Makin, 1996); (ii) envelop of a less intense consonants can be masked by high intense vowels resulting in the degradation of the envelop, leading to imperceptions of that particular consonant (Brokx & Nootboom 1982; Turner, Souza & Forget, 1995). However, enhancing envelop of consonant prevent it from the upward spread of masking caused by vowels, due to increased amplitude of consonant portion. Because of the above reasons, cochlear hearing loss individuals perform better with processed recognition condition.

4.2 Sentence recognition threshold in noise (SNR-50)

Sentence recognition threshold in noise (SNR-50) was obtained in both unprocessed and processed condition among individuals with normal hearing and cochlear hearing loss. Both the groups obtained lower SNR values in processed than unprocessed condition as shown in figure 4.4.

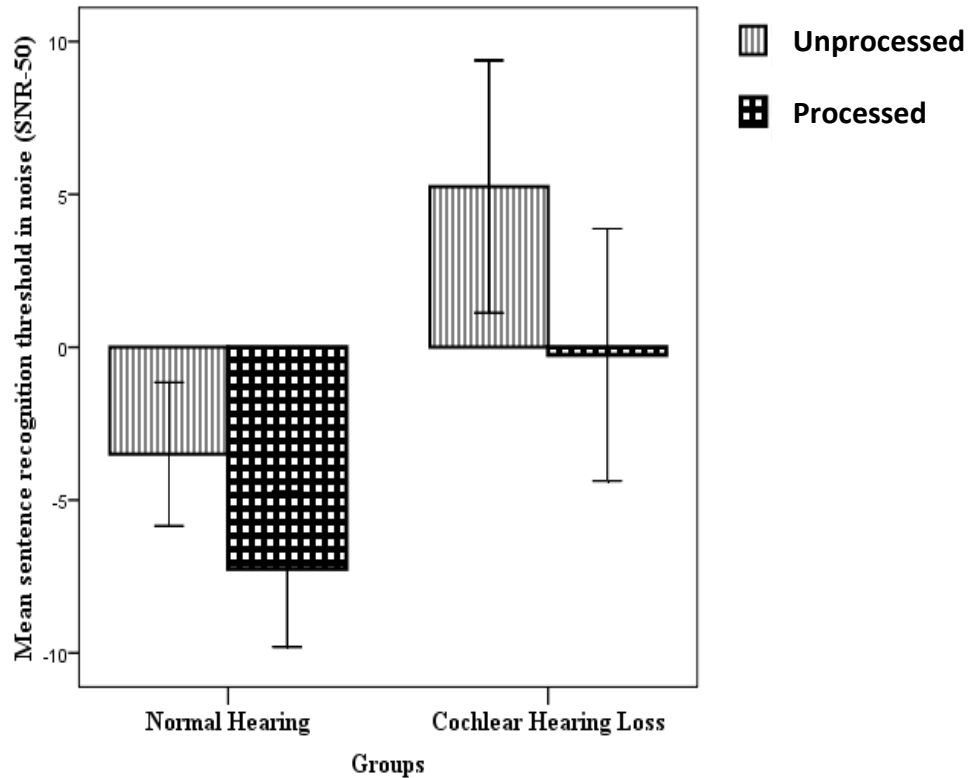

Figure 4.4: Mean and standard deviation (SD) of unprocessed and processed sentence recognition threshold in noise (SNR-50) in normal hearing and cochlear hearing loss group. Error bars indicate SD.

To analyze whether mean differences between conditions for both the groups reached significance, MANOVA was performed. Analysis revealed significant difference between both the groups in unprocessed [$F(1, 38) = 67.85, P < 0.05$] and processed [$F(1, 38) = 41.609, p < 0.05$]. A comparison across the groups indicated that sentence recognition threshold in noise (SNR-50) for the group with normal hearing was lower than the group with cochlear hearing loss in both the conditions.

Sentence recognition threshold in noise (SNR-50) was compared between unprocessed and processed condition in both normal hearing individuals and cochlear hearing loss individuals using paired sample t-test. The results of the paired 't' test is given in table 4.1.

Table 4.1: Paired 't' test results for sentence recognition threshold in noise (SNR-50) in normal hearing and cochlear hearing loss individuals

Subjects	Condition	Mean	SD	t-value
Normal hearing	Unprocessed	-3.50	2.35	7.55*
	Processed	-7.25	2.55	
Cochlear hearing loss	Unprocessed	5.25	4.12	15.98*
	Processed	-0.25	4.12	

*p < 0.05

From table 4.1, it can be described that mean sentence recognition threshold in noise (SNR-50) is significantly lower in processed condition than in non-processed condition for both the groups. In the processed condition, normal hearing individuals are able to perform at an average of -3 dB to -4 dB lower SNR levels compared to non-processed condition, whereas cochlear hearing loss individuals were able to perform at an average of -5 dB lower SNR levels than unprocessed condition.

In the present study, individuals with cochlear hearing loss required +7 dB higher SNR for sentence recognition threshold in noise (SNR-50) than the normal hearing individuals. These results are in agreement with those of previous studies (Plomp, 1994; Needleman & Crandell, 1995; Bacon, Opie & Montoya, 1998). The reason for obtaining higher SNRs in individuals with cochlear hearing loss may be due to broader auditory filters, which degrades the spectrum of the speech signal (Glasberg & Moore, 1986; Tyler, Wood & Fernandes, 1982). In addition to this, adding background noise further reduces the spectral prominence in the speech signal. Also, because of the loudness recruitment, speech sound with maximum energy can mask out the other speech sounds which are less intense. As a result, envelop of speech signal would be distorted which can result in reduced modulation depth. This can further impair the speech perception when an additional background noise is added to it.

Because of the above mentioned reasons, individuals with cochlear hearing loss have more significant problem than those with normal hearing.

Using the spectral enhancement through companding strategy, both the groups obtained lower SNRs in processed than unprocessed condition. To our knowledge, many other studies (Baer, Moore & Gatehouse, 1993; Yang, Luo & Nehorai, 2003; Frank et al, 1999) have also obtained similar findings using different strategies. But, these studies cannot be directly compared with the present study, due to the larger differences in the signal enhancing strategies employed.

In the unprocessed condition, the speech signal will be degraded in the presence of noise, making the listeners more difficult to identify the words in the sentences. This is because of reduced spectral contrast (Moore & Glasberg, 1983; Leek, Dorman & Summerfield, 1987) and distorted envelop of the speech signal (Brokx & Nooteboom 1982; Turner, Souza & Forget, 1995). Bhattacharya and Zeng (2007) have shown that spectral contrast in the processed signal significantly enhanced compared to unprocessed condition. The improvement observed for CI individuals in their study is attributed to increased spectral contrast. Similarly, Oxenham et al. (2006) have demonstrated similar results. In the present study improvement observed in the processed condition, can be attributed to enhanced spectral contrast. In addition, the companding strategy also enhances the envelope of the signal which would have enhanced the less intense speech sounds, preventing it from the upward spread of masking by high intense vowels. Hence, subjects obtained lower SNRs in the processed than unprocessed condition.

To summarize, spectral enhancement improved consonant and sentence perception for both the individuals with normal hearing and cochlear hearing loss. The amount of improvement observed was higher for cochlear hearing loss than normal hearing listeners.

CHAPTER 5

SUMMARY AND CONCLUSION

Individuals with cochlear hearing loss are able to understand speech similar to those with normal hearing in quiet listening conditions (Plomp, 1978). However, in the presence of noise, they perform more poorly in understanding speech compared to the normals (Plomp & Mimpen, 1979). Several investigators (Plomp, 1978; Scharf, 1978; Glasberg & Moore, 1986; Leek & Summers, 1993) have suggested that the poorer performance in noise could be due to the poorer frequency resolution, loudness recruitment, or upward and downward spread of masking.

For improvement of speech recognition in noise various signal processing strategies have been studied over many years. One such technique involves spectral contrast enhancement using companding strategy. Many studies have been conducted using this strategy in cochlear implant users and have shown significant improvement. However, there is a dearth of studies done using this companding strategy in cochlear hearing loss individuals. Hence the current study was taken up.

The present study aimed to assess the benefit of spectral contrast enhancement using companding strategy in individuals with cochlear hearing loss. Twenty adult subjects having normal hearing and cochlear hearing loss participated in the study. Testing involved twenty consonants in the context of vowel /a/ across different listening conditions (quiet and in the presence of speech shaped noise at different SNRs that is., 15 dB, 10 dB and 0 dB SNR) and sentences in Kannada developed by Avinash et al. (2008). These stimuli were presented in unprocessed (original) and processed (spectrally enhanced using companding strategy) condition to both the group of subjects. This companding strategy was implemented in MATLAB. Numbers of

correctly recognised consonants were calculated for the consonant recognition task. The SNR level at which 50 % of the correct responses were obtained (SNR-50) using sentences across different SNRs (+20 dB to -10 dB SNR) was found.

The results of the present study are summarised as follows:

1. Individuals with normal hearing performed better than those with cochlear hearing loss in consonant recognition task across all of the listening conditions (quiet, 15 dB, 10 dB and 0 dB SNR). Both the subjects obtained poorer scores as the SNR was reduced. However, it was more evident for those with cochlear hearing loss than normal hearing individuals.
2. Processed condition of consonant recognition scores lead to higher performance than unprocessed in both the groups. Significant improvement was found at 0 dB SNR (12 %) for normal hearing individuals and at 15 dB (4.5 %), 10 dB (5.25 %) and 0 dB SNR (18.75 %) for those with cochlear hearing loss.
3. In sentence recognition threshold in noise (SNR-50) task, individuals with cochlear hearing loss required higher SNRs compared to normal hearing individuals in both the unprocessed and processed condition. Both the subjects performed at lower SNR levels in processed than unprocessed condition. Improvement found was about -3.75 dB SNR for normal hearing individuals and -5 dB SNR for those with cochlear hearing loss.

From the above findings, it can be concluded that spectrally enhanced speech through companding strategy improves the speech perception in noise in individuals with cochlear hearing loss to a much greater extent than do for normal hearing individuals.

Clinical implications:

1. The results have highlighted that spectral enhancement using companding strategy has the potential to improve speech performance in the presence of noise in cochlear hearing loss individuals.
2. Spectral enhancement using companding strategy can be implemented in amplification devices for the benefit of speech recognition in adverse listening conditions.

REFERENCES

- ANSI (1989). S3.6-1989 Specifications for audiometers. American National Standards Institute, New York.
- Avinash, M.C., Methi, R., & Kumar, U. A. (2008). Development of sentence material for Quick Speech in Noise test (Quick SIN) in Kannada. *Journal of Indian speech and Hearing Association*, 23, 59-65.
- Bacon, S.P., Opie, J.M., & Montoya, D.Y. (1998). The effects of hearing loss and noise masking on the masking release for speech in temporally complex backgrounds. *Journal of Speech, Language, and Hearing Research*, 41, 549-563.
- Baer, T., & Moore, B.C.J. (1993). Effects of spectral smearing on the intelligibility of sentences in the presence of noise. *Journal of the Acoustical Society of America*, 94, 1229–1241.
- Baer, T., & Moore, B.C.J. (1994). Effects of spectral smearing on the intelligibility of sentences in the presence of interfering speech. *Journal of the Acoustical Society of America*, 95, 2277-2280.
- Baer, T., Moore, B.C.J., & Gatehouse, S. (1993). Spectral contrast enhancement of speech in noise for listeners with sensorineural hearing impairment: Effects on intelligibility, quality, and response times. *Journal of Rehabilitation Research and Development*, 30, 49–72.
- Bhattacharya, A., & Zeng, F. (2007). Companding to improve cochlear-implant speech recognition in speech-shaped noise. *Journal of the Acoustical Society of America*, 122, 1079-1089.

- Brokx, J.P.L., & Nootboom, S.G. (1982). Intonation and the perception of simultaneous voices. *Journal of Phonetics*, *10*, 23–26.
- Bronkhorst, A.W., & Plomp, R. (1989). Binaural speech intelligibility in noise for hearingimpaired listeners. *Journal of the Acoustical Society of America*, *86*, 1374-1383.
- Bunnell, H.T. (1990). On enhancement of spectral contrast in speech for hearing-impaired listeners. *Journal of the Acoustical Society of America*, *88*, 2546–2556.
- Ching, T., Dillon, H., & Byrne, D. (1997). Prediction of Speech Recognition from Audibility and Psychoacoustic Abilities of Hearing-Impaired Listeners, in *Modeling Sensorineural Hearing Loss*, Erlbaum, *Mahwah, NJ*, 433-445.
- Ching, T., Dillon, H., & Byrne, D. (1998). Speech recognition of hearing-impaired listeners: Predictions from audibility and the limited role of high-frequency amplification. *Journal of the Acoustical Society of America*, *103*, 1128-1140.
- Clarkson, P.M., & Bahgat, S.F. (1991). Envelope expansion methods for speech enhancement. *Journal of the Acoustical Society of America*, *89*, 1378–1382.
- Dubno, J., Dirks, D., & Morgan, D. (1982). Effect of age and mild hearing loss on speech recognition in noise. *Journal of the Acoustical Society of America*, *76*, 87-96.
- Dubno, J.R., & Dirks, D.D. (1989). Auditory filter characteristics and consonant recognition for hearing-impaired listeners. *Journal of the Acoustical Society of America*, *85*, 1666-1675.

- Dubno, J.R., & Schaefer, A.B. (1992) Comparison of frequency selectivity and consonant recognition among hearing-impaired and masked normal-hearing listeners. *Journal of the Acoustical Society of America*, *91*, 2110-2121.
- Fabry, D.A., & van Tasell, D.J. (1986). Masked and filtered simulation of hearing loss: Effects on consonant recognition. *Journal of Speech and Hearing Research*, *29*, 170-178.
- Fowler, E.P. (1936). A method for the early detection of otosclerosis. *Archives of Otolaryngology*, *24*, 731-741.
- Franck, B. A., van Kreveld-Bos, C.S., Dreschler, W. A., & Verschuure, H. (1999). Evaluation of spectral enhancement in hearing aids, combined with phonemic compression. *Journal of the Acoustical Society of America*, *106*, 1452-1464.
- Glasberg, B.R., & Moore, B.C.J. (1986). Auditory filter shapes in subjects with unilateral and bilateral cochlear impairments. *Journal of the Acoustical Society of America*, *79*, 1020-1033.
- Glasberg, B.R., & Moore, B.C.J. (1989). Psychoacoustic abilities of subjects with unilateral and bilateral cochlear impairments and their relationship to the ability to understand speech. *Scandinavian Audiology*, *32*, 1-25.
- Hogan, C.A., & Turner, C.W. (1998). High-frequency audibility: Benefits for hearing-impaired listeners. *Journal of the Acoustical Society of America*, *104*, 432-441.
- Humes, L.E., Dirks, D.D., & Kincaid, G.E. (1987). Recognition of nonsense syllables by hearing-impaired listeners and by noise masked normal listeners. *Journal of the Acoustical Society of America*, *81*, 765-773.

- Kiang, N.Y.S., Moxon, E.C., & Levine, R.A. (1970). Auditory Nerve Activity in Cats with Normal and Abnormal Cochleas, in *Sensorineural Hearing Loss*, Churchill, London, 241-268.
- Killion, M., & Niquette, P. (2000). What can the pure tone audiogram tell us about a patient's SNR loss?. *The Hearing Journal*, 53, 46-53.
- Lee, L.W., & Humes, L.E. (1993). Evaluating a speech-reception threshold model for hearing-impaired listeners. *Journal of the Acoustical Society of America*, 93, 2879-2885.
- Leek, M.R., Dorman, M.F., & Summerfield, Q. (1987). Minimum spectral contrast for vowel identification by normal hearing and hearing-impaired listeners. *Journal of the Acoustical Society of America*, 81, 148-54.
- Leek, M.R., & Summers, V. (1993). Auditory filter shapes of normal-hearing and hearing-impaired listeners in continuous broadband noise. *Journal of the Acoustical Society of America*, 94, 3127-3137.
- Moore, B.C.J. (1997). A compact disc containing simulations of hearing impairment. *British Journal of Audiology*, 31, 353-357.
- Moore, B.C.J., & Glasberg, B.R. (1983). Masking patterns of synthetic vowels in simultaneous and forward masking. *Journal of the Acoustical Society of America*, 73, 906-917.
- Moore, B.C.J., & Glasberg, B.R. (1993). Simulation of the effects of loudness recruitment and threshold elevation on the intelligibility of speech in quiet and

- in a background of speech. *Journal of the Acoustical Society of America*, 94, 2050-2062.
- Moore, B.C.J., Glasberg, B.R., & Simpson, A. (1992). Evaluation of a method of simulating reduced frequency selectivity. *Journal of the Acoustical Society of America*, 91, 3402-3423.
- Moore, B.C.J. (2007). *Cochlear Hearing Loss: Physiological, Psychological and Technical issues*. England: John Wiley & sons Ltd.
- Needleman, A.R. & Crandell, C.C. (1995). Speech recognition in noise by hearing-impaired and noise-masked normal-hearing listeners. *Journal of the American Academy of Audiology*, 6, 414-424.
- Nejime, Y. & Moore, B.C.J. (1997). Simulation of the effect of threshold elevation and loudness recruitment combined with reduced frequency selectivity on the intelligibility of speech in noise. *Journal of the Acoustical Society of America*, 102, 603-615.
- Oxenham, A. J., Simonson, A. M., Turicchia, L., & Sarpeshkar, R. (2007). "Evaluation of companding-based spectral enhancement using simulated cochlear-implant processing. *Journal of the Acoustical Society of America*, 121, 1709–1716.
- Pascoe, D.P. (1980). Clinical implications of nonverbal methods of hearing aid selection and fitting. *Speech, Language & Hearing*, 1, 217-229.
- Pavlovic, C. (1984). Derivation of primary parameters and procedures for use in speech intelligibility predictions. *Journal of the Acoustical Society of America*, 82, 413-422.

- Plomp, R. (1978). Auditory handicap of hearing impairment and the limited benefit of hearing aids. *Journal of the Acoustical Society of America*, 63, 533-549.
- Plomp, R. (1986). A signal-to-noise ratio model for the speech-reception threshold for the hearing impaired. *Journal of Speech and Hearing Research*, 29, 146-55.
- Plomp, R. (1994). Noise, amplification, and compression: Considerations of 3 main issues in hearing-aid design. *Ear and Hearing*, 15, 2-12.
- Plomp, R. & Mimpen, A.M. (1979). Improving the reliability of testing the speech reception threshold for sentences. *Audiology*, 18, 43-53.
- Preminger, J. & Wiley, T.L. (1985). Frequency selectivity and consonant intelligibility in sensorineural hearing loss. *Journal of Speech and Hearing Research*, 28, 197-206.
- Ruggero, M. A., Robles, L., & Rich, N. C. (1992). Two-tone suppression in the basilar membrane of the cochlea: Mechanical basis of auditory nerve rate suppression. *Journal of Neurophysiology*, 68, 1087-1099.
- Scharf, B. (1978). Comparison of normal and impaired hearing II: Frequency analysis, speech perception. *Scandinavian Audiology*, 6, 81-106.
- Schmiedt, R.A. (1996). Effects of aging on potassium homeostasis and the endocochlear potential in the gerbil cochlea. *Hearing Research*, 102, 125-132.
- Schorn, K., & Zwicker, E. (1990). Frequency selectivity and temporal resolution in patients with various inner ear disorders. *Audiology*, 29, 8-20.

- Simpson, A. M., Moore, B. C. J., & Glasberg, B. R. (1990). Spectral enhancement to improve the intelligibility of speech in noise for hearing-impaired listeners. *Acta Oto-Laryngology*, *469*, 101-107.
- Thibodeau, L.M., & van Tasell, D.J. (1987). Tone detection and synthetic speech discrimination in band-reject noise by hearing-impaired listeners. *Journal of the Acoustical Society of America*, *82*, 864-873.
- Turicchia, L., & Sarpeshkar, R. (2005). A bio-inspired companding strategy for spectral enhancement. *IEEE Trans. Acoust., Speech, Signal Process.* *13*, 243–253.
- Turner, C.W., Souza, P.E., & Forget, L.N. (1995). Use of temporal envelope cues in speech recognition by normal and hearing-impaired listeners. *Journal of the Acoustical Society of America*, *97*, 2568–2576.
- Tyler, R.S., Wood, E.J., & Fernandes, M.A. (1982). Frequency resolution and hearing loss. *British Journal of Audiology*, *16*, 45-63.
- Watkins, A.J., & Makin, S.J. (1996). Effects of spectral contrast on perceptual compensation for spectral-envelope distortion. *Journal of the Acoustical Society of America*, *99*, 3749–3757.
- Yang, J., Luo, F., & Nehorai, A. (2003). Spectral contrast enhancement: algorithms and comparisons. *Speech communication*, *39*, 33-46.
- Zurek, P.M., & Delhorne, L.A. (1987). Consonant reception in noise by listeners with mild and moderate sensorineural hearing impairment. *Journal of the Acoustical Society of America*, *82*, 1548-1559.