



Deep learning for healthcare applications based on physiological signals: A review

Oliver Faust^{a,*}, Yuki Hagiwara^b, Tan Jen Hong^b, Oh Shu Lih^b, U Rajendra Acharya^{b,c,d}

^a Department of Engineering and Mathematics, Sheffield Hallam University, United Kingdom

^b Department of Electronic & Computer Engineering, Ngee Ann Polytechnic, Singapore

^c Department of Biomedical Engineering, School of Science and Technology, SIM University, Singapore

^d Department of Biomedical Imaging, Faculty of Medicine, University of Malaya, Kuala Lumpur, Malaysia

ARTICLE INFO

Article history:

Received 24 January 2018

Revised 23 March 2018

Accepted 2 April 2018

Keywords:

Deep learning
Physiological signals
Electrocardiogram
Electroencephalogram
Electromyogram
Electrooculogram

ABSTRACT

Background and objective: We have cast the net into the ocean of knowledge to retrieve the latest scientific research on deep learning methods for physiological signals. We found 53 research papers on this topic, published from 01.01.2008 to 31.12.2017.

Methods: An initial bibliometric analysis shows that the reviewed papers focused on Electromyogram (EMG), Electroencephalogram (EEG), Electrocardiogram (ECG), and Electrooculogram (EOG). These four categories were used to structure the subsequent content review.

Results: During the content review, we understood that deep learning performs better for big and varied datasets than classic analysis and machine classification methods. Deep learning algorithms try to develop the model by using all the available input.

Conclusions: This review paper depicts the application of various deep learning algorithms used till recently, but in future it will be used for more healthcare areas to improve the quality of diagnosis.

© 2018 Elsevier B.V. All rights reserved.

1. Introduction

Physiological signals are an invaluable data source which assists in disease detection, rehabilitation, and treatment [1]. The signals come from sensors implanted or placed on the skin [2]. The application areas dictate where the sensors are to be placed [3,4]. In turn, the sensor location determines the characteristics of the physiological signal. Relevant information must be extracted from the physiological signal in order to support a specific healthcare application [5,6]. It is difficult to establish what constitutes relevant information, because various medical ontologies can be used for data interpretation [7]. It is unavoidable that these ontologies contain conflicts and inconsistencies [8]. Another fundamental problem is that physiological signal interpretation suffers from intra-individual variability [9]. For example, both electrode position and noise influence the signal waveform [10]. Therefore, human interpretation requires years of training to acquire specialized knowledge. Even with expert knowledge, manual physiological signal interpretation suffers from intra- and inter-operator variability [11]. Furthermore, physiological signal interpretation is a tiresome process where human errors can be caused by fatigue [12,13]. Com-

puter supported signal analysis is not affected by fatigue related mistakes and it can also eliminate both intra- as well as inter-observer variability. In addition, most computer based analysis interpretation can be done quicker and more cost effective when compared to human interpretation [14]. Having established the need for computer based physiological signal analysis, we have to find the most appropriate processing methods for a given healthcare application.

Nowadays, performance measures, such as classification accuracies [15,16], govern computer based analysis and classification of physiological signals for healthcare applications [17–19]. The goal is to design algorithms that outperform the established methods [20]. The design process is based on the idea of having an offline and online system, as shown in Fig. 1 [21,22]. The offline system is used to design the required algorithm structure based on labelled data. That algorithm structure is used in the online system to process measurement data. In most of the cases, the system consists of three sequential processing steps: (1) preprocessing [23,24], (2) feature extraction [25,26] (3) classification [27]. The first two steps establish the analysis system which extracts information from the physiological signal. This approach is very target directed, since the design process is governed by the feature performance. However, real competition is difficult to establish, because the underlying testing data are rarely comparable. Another problem is that,

* Corresponding author.

E-mail address: o.faust@shu.ac.uk (O. Faust).

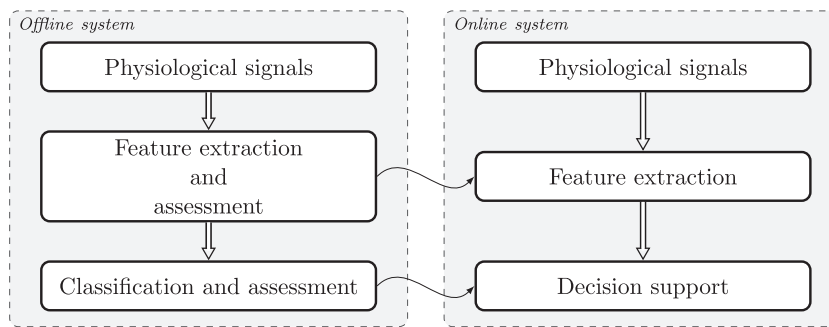

Fig. 1. Block diagram for the design of a traditional decision support system based on physiological signals.

there is no way of knowing which feature extraction algorithm is suitable for a given problem. The feature quality can only be established a posteriori with statistical methods [28,29]. This situation is dissatisfactory for two reasons. Various feature extraction algorithms must be evaluated on the physiological signals before selecting the best performing feature extraction method. Even the increased effort fails to ensure that the most relevant information are extracted. The second reason comes from the fact that only a small number of features are used for decision making, because the performance of decision making algorithms deteriorates for higher dimensional inputs [30]. Hence, the main design goal of current decision support systems is to restrict the amount of information that underpins the decision making [31]. Having to restrict the amount of information for the decision-making process is a big problem, because the decision quality will suffer. The negative effects become more prominent for large and diverse physiological signal datasets that hold the information to tackle more challenging application areas, such as Brain Computer Interface (BCI), cardiovascular diseases, sleep apnea, sleep stages and muscular abnormalities. Current decision-making systems under-perform for large and varied datasets, because they fail to process information that is sufficiently diverse to cover all scenarios. More depth is required to represent all the information in a dataset. Fundamentally, we require implicit knowledge to make good decisions based on the information extracted from physiological signals. In the past, that implicit knowledge was exclusively found in highly skilled medical practitioners. Deep learning was designed to overcome these shortcomings by taking into consideration all information a training dataset has to offer. The method promises to establish implicit knowledge in a machine. In this review, we investigate the validity of this claim by analysing the ways in which deep learning has been applied to physiological signals. We found promising research in the areas of (ECG), (EEG), (EMG) and (EOG) based healthcare applications. However, the amount of research work does not reflect the diversity of healthcare application that can benefit from physiological signal interpretation. Therefore, we adopt the position that the diversification of the research is needed. The depth and specialization must come from training the deep learning algorithms with larger and more varied data sets.

To support our claim that deep learning is a major step towards understanding physiological signals, we have organized the remainder of the paper as follows. The next section establishes the importance of implicit knowledge for physiological signal interpretation and it provides background on deep learning. Section 3 presents bibliometric and content analysis results. Based on these results, we put forward a range of research gaps in the discussion section. In this section, we have also discussed limitations and future work. The paper concludes with Section 5.

2. Background

Physiological signals reflect the electrical activity of a specific body part [6]. As such, the electrical activity provides information about the physiological condition. Traditionally, this information can be used by medical practitioners for decision making [32,33]. These decisions have far reaching consequences on diagnosis, treatment monitoring, drug efficacy tests, and quality of life. From a machine learning perspective, a medical practitioner is an intelligent agent who makes good decisions. In order to reach these decisions some sort of knowledge is required. This knowledge shapes the process which generates actions from both state and input. For example, a clinician analyses an ECG signal. As that analysis process continues, there is a growing suspicion that the signal was taken from a patient with coronary artery disease. More and more suspicious waveform segments emerge until a positive diagnosis is reached. From a processing perspective, the ECG signal is the input, the reading clinician is the system and the system state is reflected in the growing suspicion.

In its simplest form, knowledge can be explicitly expressed as mathematical rules and physical facts. Engineers make use of this explicit knowledge to create expert systems [34]. However, these systems are limited to a specific domain and they operate in highly controlled environments. Only for these environments, we are reasonably sure about the physical facts and mathematical rules which shape the correct behaviour. Furthermore, expert systems don't reflect the concept of suspicion and common sense. Overcoming these limitations requires implicit knowledge which can be found in the complex wiring and the synaptic setup of biological brains as well as the mechanical and sensory properties of biological bodies. The only way for computers to mimic implicit knowledge is to learn from examples. The idea is to find a way to learn general features in order to make sense of new data. This description highlights the central role of data for establishing implicit knowledge. The amount of data must be sufficiently large to provide many training examples from which a large set of parameters can be extracted. Only a large number of parameters give rise to the richness of class functions which model the implicit knowledge.

Deep learning is a change in basic assumptions of artificial intelligence algorithm design [35]. This change percolates through to all application areas of machine learning, such as computer vision, speech recognition, natural language processing and indeed diagnosis support [36]. Central to deep learning are the ideas of parallel processing and networked entities. The next section details these ideas by discussing the deep learning methods.

2.1. Deep learning methods

Deep learning belongs to the class of machine learning methods. It is a special form of representation-based learning, where a

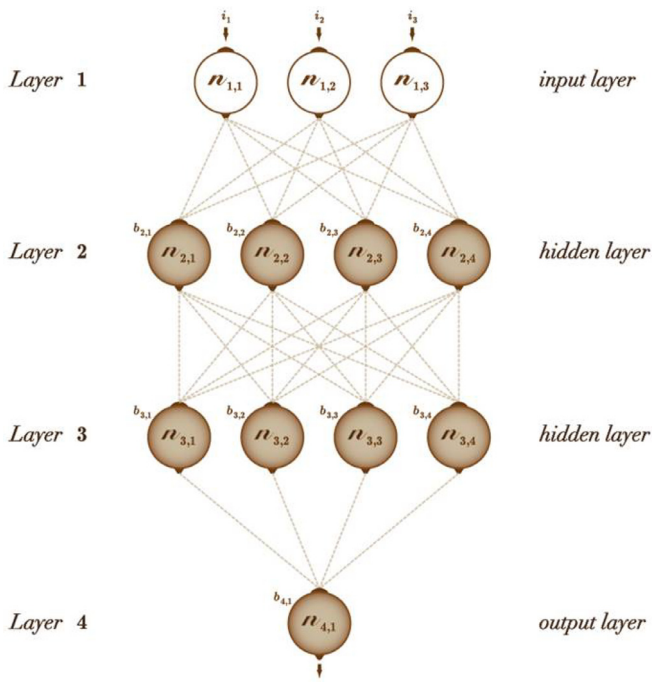

Fig. 2. Traditional ANN.

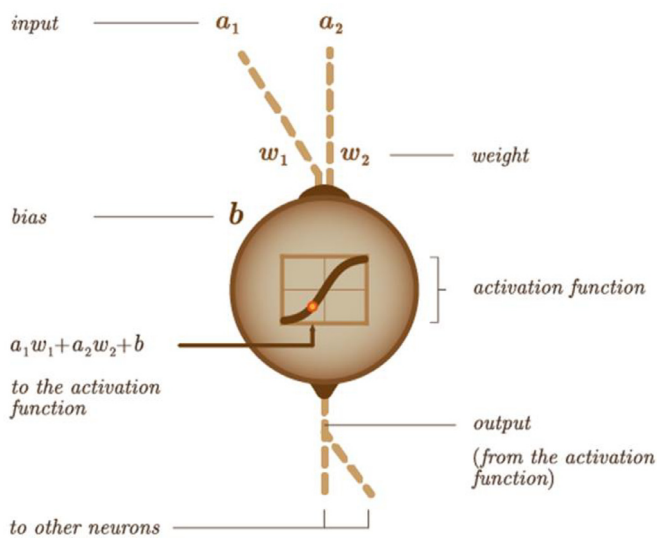

Fig. 3. Neuron structure.

network learns and constructs inherent features from each successive hidden layer of neurons [31]. The term “deep” is derived from the numerous hidden layers in the Artificial Neural Network(ANN) structure.

The ANN algorithm models the functionality of a biological brain [37]. The model is realized with a structure that is made up of input-, hidden-, and output-layers, as shown in Fig. 2. Every neuron or node (nerve cell) is connected to each neuron in the next layer through a connection link. A nerve cell is made up of axon (output), dendrites (input), a node (soma), nucleus (activation function), and synapses (weights) [38]. The activation function in the artificial neuron acts as the nucleus in a biological neuron whereas the input signals and its respective weights model the dendrites and synapses respectively. Fig. 3 illustrates the neuron structure.

Unfortunately, the ANN structure is receptive to translation and shift deviation, which may adversely affect the classification performance [39]. To eliminate these shortcomings, an extended version of ANN, the Convolutional Neural Network(CNN), was developed [40]. The CNN architecture ensures translation and shift invariance [41]. Fig. 4 illustrates a generic CNN network structure. It is a feed-forward network, which comprises of: convolution, pooling, and fully-connected, layers [41]. They are briefly explained below.

1. Convolution layer: The input sample is convolved with a kernel (weights) in this layer. The output of this layer is the feature map. The stride controls how much the kernel convolves with the input sample. The convolution operation acts as a feature extractor by learning from the diverse input signals. The extracted features can be used for classification in subsequent layers. Fig. 5 illustrates a convolution operation between f (input) and g (kernel), giving an output c . Eqs. (1) and (2) provide an example of the convolution calculation.

$$\begin{aligned} c(1) &= 1 \times 3 + 2 \times 4 + 3 \times 1 = 14 \\ c(2) &= 2 \times 3 + 3 \times 4 + 4 \times 1 = 22 \\ c(3) &= 3 \times 3 + 4 \times 4 + 5 \times 1 = 30 \end{aligned} \quad (1)$$

$$\begin{aligned} \text{Output1} &= 22 \times W_1 + 38 \times W_3 + 54 \times W_5 \\ \text{Output2} &= 22 \times W_2 + 38 \times W_4 + 54 \times W_6 \end{aligned} \quad (2)$$

2. Pooling layer: This is a down-sampling layer where the pooling operation is employed to reduce the spatial dimension of the input sample, while retaining the significant information. The pooling operation can be average, max, or sum. The max-pooling operation is typically employed. An example of a max-pooling operation, with a stride of 2, is shown Fig. 6. In this example, the number of input samples are halved by retaining only the maximum value within a selected stride. In a stride that contains 14 and 22, the value 22 is retained, and, 14 is discarded.
3. Fully-connected layer: Fully-connected signifies that each neuron in the previous layer is connected to all the neurons in the current layer. The total number of fully-connected neurons in the final layer determines the number of classes. Fig. 7 provides a graphical representation of a fully-connected layer. The neurons are all connected and each connection has a specific weight. This layer establishes a weighted sum of all the outputs from the previous layer to determine a specific target output.

A leaky rectifier linear unit [42] is used as an activation function after the convolution layer. The purpose is to map the output to the input set and introduce non-linearity as well as sparsity to the network. The CNN is trained with backpropagation [43] and the hyperparameters may be tuned for optimal training performance.

In addition to CNN, there are other deep learning architectures, such as autoencoder [44], deep generative models [45,46] and Recurrent Neural Network(RNN), that can be used to monitor the physiological signals [47].

The autoencoder is an unsupervised neural network that is trained to imitate the input to its output. The dimension of the input is the same as the dimension of the output. The encoders are stacked together to form a deep autoencoder network. The autoencoder takes unlabelled inputs, encodes these inputs, and subsequently it reconstructs the inputs as precisely as possible. Hence, the network structure must determine which data features are significant. An autoencoder consists of *three* layers: input, output, and hidden. Encoding and decoding are the two main steps in the autoencoder algorithm. During encoding and decoding, the same weights are employed to encode the feature and reconstruct an output sample in the output. Autoencoders are trained with a

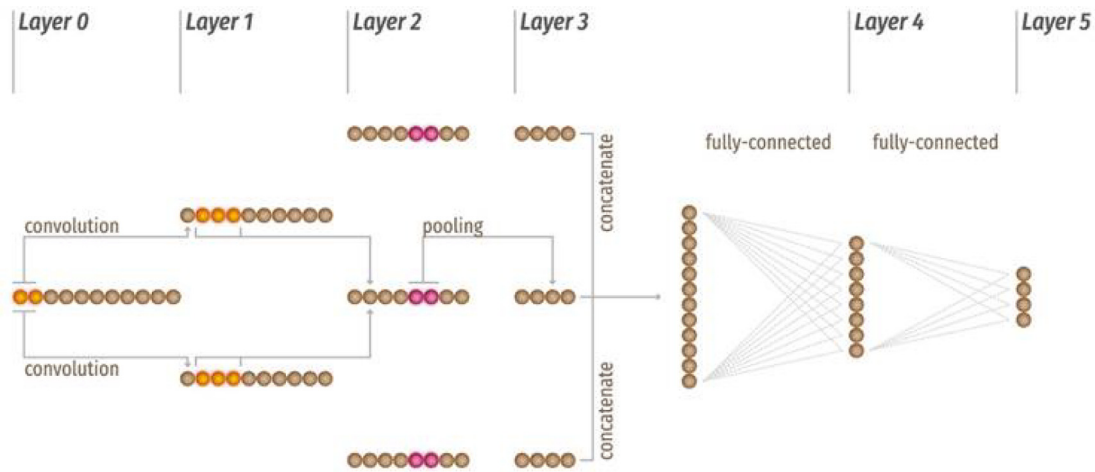

Fig. 4. CNN network structure.

$$c = f * g$$

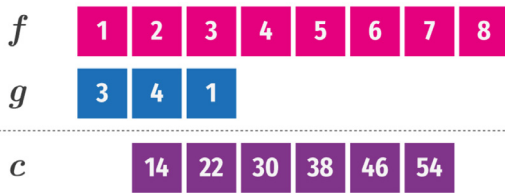

Fig. 5. Convolution layer.

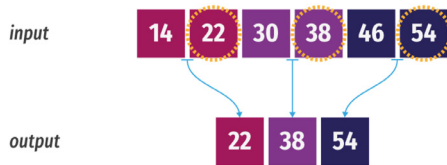

Fig. 6. Max pooling layer.

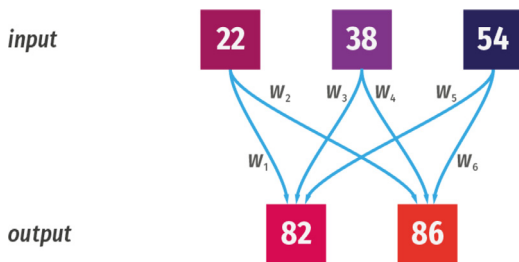

Fig. 7. Fully connected layer.

backpropagation algorithm that employs a metric known as the loss function [43]. That function computes the amount of information which is lost during input reconstruction. Thus, a network structure with a small loss value will produce a reconstruction that is nearly identical to the input sample [37].

Deep Belief Network(DBN) [45] and Restricted Boltzmann Machine(RBM) [48] are common forms of the deep generative model, where DBNs are stacked layers of RBM. The RBM is made up of a two-layer neural net with one visible and one hidden layer. Each node in the layer learns a single feature from the input data by making random decisions on whether to transmit the input or not. The nodes in the first (visible) layer are connected to every node

in the second (hidden) layer. The RBM takes the inputs and translates them into a set of numbers that encode the inputs. Then, a backward translation is implemented to reconstruct the inputs. The RBM network is trained to reconstruct through forward and backward passes [49, Chapter 6].

The DBN is a probabilistic model with several hidden layers [50]. It can be efficiently trained by using a technique known as greedy layer-wise pre-training [51]. Typically, the DBNs are stacked layers of RBM. The first layer of the RBM is trained to reconstruct its input. After which, the first hidden layer is considered as the visible layer and it is trained using the outputs from the input layer. This process is iterated until all layers in the structure are trained [45].

In contrast to the feed-forward network, the RNN employs a recursive approach (recurrent network) whereby the network performs a routine task with the output being dependent on the previous computation. This functionality is created with inbuilt memory. The most common type of RNN is the Long Short-Term Memory(LSTM) network [52]. It has the capability to learn long-term dependencies. The LSTM algorithm incorporates a memory block with three gates: the input, output, and forget gate. These gates control the cell state and decide which information to add or remove from the network. This process repeats for every input.

1. Input gate: decides what new information is to be stored and updated in the cell state.
2. Output gate: judges what information is used based on the cell state.
3. Forget gate: evaluates what information is redundant and discards it from the cell state.

These deep learning architectures have demonstrated their potential by surpassing the performance of traditional machine learning techniques [31]. Furthermore, deep learning algorithms minimize the need for feature engineering. The next section, focuses on scientific work that applied deep learning to physiological signal interpretation for health care applications.

3. Review

In this review, we consider 53 articles focusing on deep learning methods applied to physiological signals for healthcare applications. These papers were published in the period from 01.01.2008 to 31.12.2017. Fig. 8 shows the yearly distribution of 53 articles together with a trend line [53]. Apart from the data distribution, the figure also features a trend line which was generated with a linear

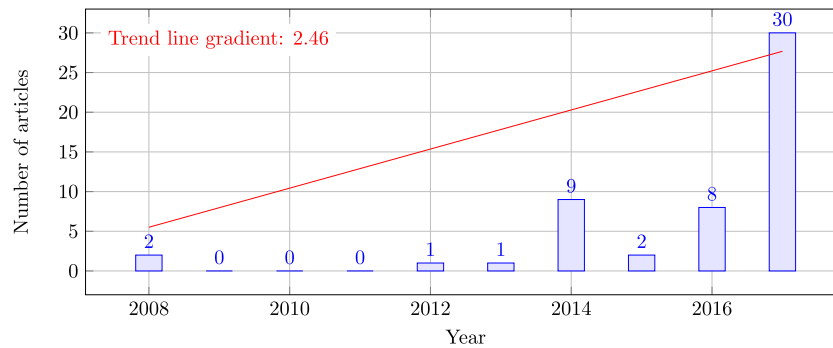

Fig. 8. Number of articles on deep learning, published each year from 01.01.2008 to 31.12.2017.

Table 1

Topic cluster summary, where C is the Cluster number. Colour indicates the cluster colour as shown in Fig. 9.

C	Topics	Colour
1	emg , cnn, cognitive states, dnn, fnirs, hand gesture, infrared spectroscopy, ml, myoelectric interfaces, prostheses, real-time, recognition, rehabilitation robotics, speech, wearable, word generation	Red
2	eeg , bci, learning, motor imagery, multifractal attribute, neuromorphic computing, noise, wavelet leader	Blue
3	ecg , aed, arrhythmia, contaminant mitigation, cvd, motion artifact	Yellow
4	eog , dbn, heartbeat, osa, rnn, signal, sleep, svm	Green

regression approach [54]. The large positive gradient of the trend line indicates more papers, on this topic, published in recent years.

Our review of the 53 articles is based on two analysis methods. The first method is a bibliometric analysis, which helps us to detect the structure that governs relationship between the paper topics. We use this information to arrange the second analysis method, which deals with the content of the reviewed papers. The paper content is dissected in terms of common parameters that enable us to compare the studies across different healthcare applications.

3.1. Bibliometric analysis

The bibliometric analysis establishes the topic structure of the reviewed papers. This unlocks the paper content. We have used the well-known VOSviewer¹ software to establish a co-occurrence network [55,56]. Before feeding the data to the VOSviewer algorithm, we created a thesaurus file to group keywords, having the same meaning, into broader topics. Table A.8 shows that mapping. Fig. 9 shows the co-occurrence network and the topic clusters. Table 1 reveals the topic structure by aligning the topics to clusters. These clusters are centred on a specific physiological signal. To be specific, the largest topic cluster² includes EMG. The physiological signals are widely used in healthcare areas, such as speech, prosthesis and rehabilitation robotics. CNN is the deep learning method of choice in this cluster. The second cluster is related to the EEG which is used for BCI. the cluster shows that noise is a problem for EEG processing. Cluster 3 focuses on ECG, which is linked to Cardiovascular Disease(CVD), arrhythmia and Automated External Defibrillator(AED). The last cluster deals with EOG which can be used to detect sleep problems. The deep learning methods of DBN and RNN are used to the detect of Obstructive Sleep Apnea(OSA) using different physiological signals. The clustering helps us to structure the content review, which is presented in the next section.

3.2. Content review

The bibliometric research shows four distinct clusters focused on four physiological signals namely: ECG, EEG, EMG and EOG. They are briefly discussed in the following sections.

3.2.1. Deep learning methods applied to EMG

The EMG measures the electrical activity of skeletal muscles [57]. The electrical sensors, known as electrodes, are placed on the skin above the muscles of interest [58]. The EMG signals indicate: muscle activation, force produced by the muscle, and muscle state [59]. All these factors are superimposed, i.e. the EMG signal measurement picks up the contributions from different sources and sums them up. Hence, it is difficult to gain information about one particular aspect by observing the EMG signal. Table 2 details the research work which describe the deep learning methods used to analyse the EMG signal. Individual columns healthcare application area, Deep Learning(DL) algorithm, the data used for the study, and the study results. As such, the DL algorithms were introduced in Section 2.1.

3.2.2. Deep learning methods applied to EEG

The EEG is measured by placing electrodes on the skull of the subject, where they pick up the electrical activity of the brain [71,72]. As such, that activity results from firing neurons emitting action potentials. At any given time, the electrode sums up many charges from different sources. The resulting EEG signal has a noise like characteristic, which makes the interpretation difficult. Furthermore, the signal is affected by EOG and EMG artifacts [73–75]. It takes the trained eye of a practitioner to spot the features that indicate a specific mental state [76]. One of the main drivers behind the application of DL algorithms applied to EEG is BCI [77]. The real-time nature of this application makes human signal interpretation impossible [78]. Hence, BCI requires automated decision making. Table 3 lists the reviewed research works conducted using deep learning with EEG signals. The list contains one exception, Huve et al. used functional near-infrared spectroscopy [79] to track neural dynamics of the brain [80].

3.2.3. Deep learning methods applied to ECG

The ECG is measured by placing electrodes on the chest [116]. These electrodes record the electrical activity of the human heart

¹ Web page (Last accessed 11.12.2017): <http://www.vosviewer.com/>

² In terms of the number of papers that include a keyword that was mapped to the cluster topics.

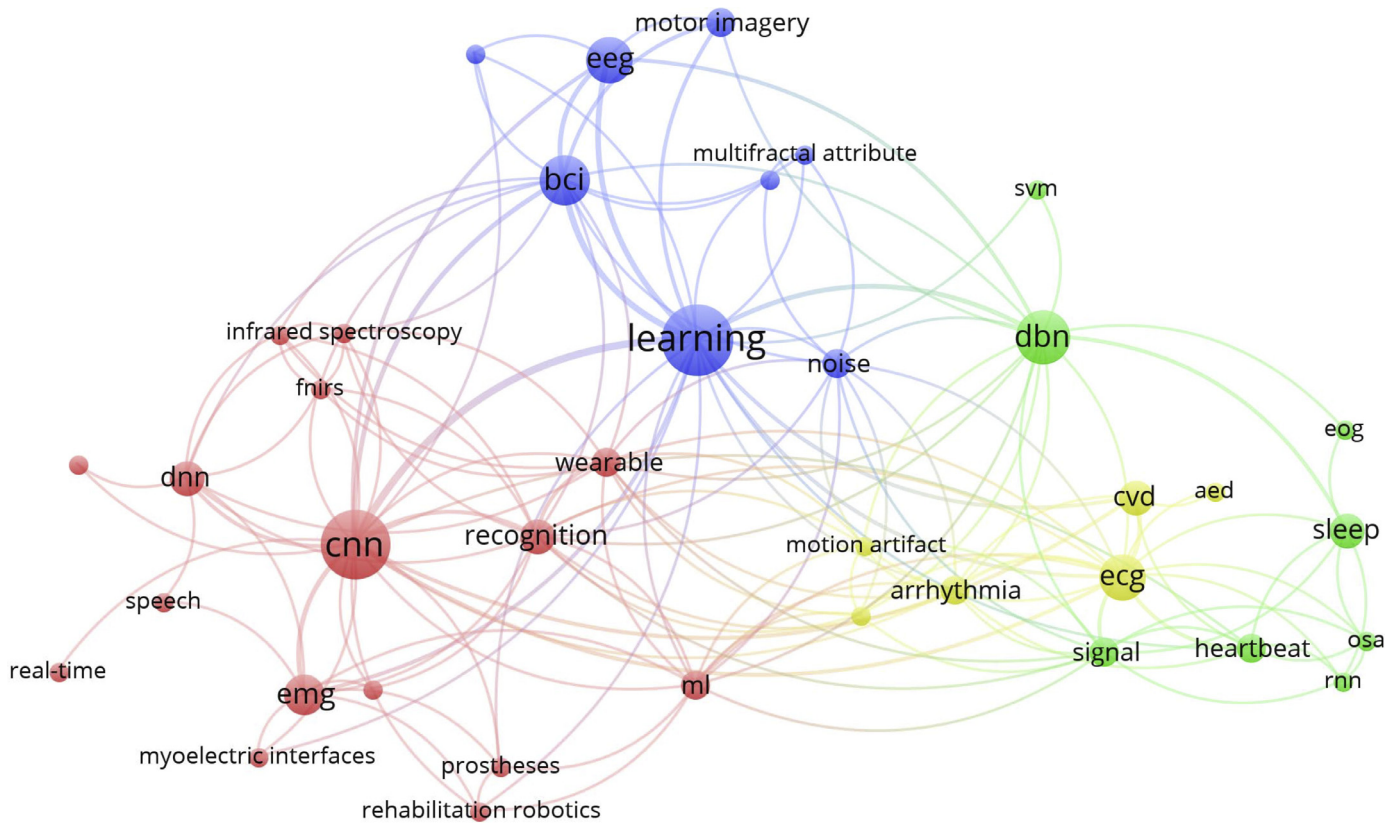

Fig. 9. Network visualization for the author supplied keywords.

Table 2
Summary of works carried out using DL algorithms with EMG signals.

Author	Application	DL algorithm	Data	Results
Xia et al., 2017 [60]	Limb movement estimation	RNN	Measurements from eight healthy subjects	The RNN outperforms other methods for estimating a 3D trajectory
Zhai et al., 2017 [61] Park et al., 2016 [63]	Neuroprosthesis control Movement intention decoding	CNN CNN	NinaPro Database(DB)2&3 [62] Kinematic and EMG data NinaPro DB [64]	accuracy: 83% accuracy: > 90%
Atzori et al., 2016 [65] Geng et al., 2016 [66]	Hand movement classification Gesture recognition	CNN CNN	NinaPro DB [62] 18 subjects performing 16 gestures each recorded 10 times	accuracy: 66.59% accuracy: 99.5%
Wand and Schmidhuber, 2016 [67]	Speech recognition	Deep Neural Network(DNN)	EMG-UKA Corpus [68]	DNN outperforms a Gaussian Mixture Model(GMM) front end
Allard et al., 2016 [69]	Robotic arm guidance	CNN	18 subjects performing 7 gestures	accuracy: \approx 97.9%
Wand and Schultz, 2014 [70]	Speech recognition	DNN	25 sessions from 25 subjects	Visualization of hidden nodes activity

[117]. The signal reflects the functioning of the heart and it has well distinguishable features, even in the time domain. The difficulty in ECG interpretation is to spot the morphological changes which indicate a particular cardiac problem [118,119] or diabetes [120,121]. These abnormalities may be minute and very often they may be transients or present all the time [122]. The research work, listed in Table 4, discusses the DL algorithms used for the automated detection of various cardiac abnormalities. The scientific work, described in 13 out of 14 reviewed papers, relies on measurements which were taken from public DBs. Therefore, the results can be compared with state-of-the-art methods. For example, Acharya et al. [123] reported the performance measures obtained through the deep learning system alongside the performance figures of the traditional diagnosis support systems. Their system

outperformed traditional approaches and it has the added benefit of not having to perform feature extraction and de-noising. Table 4 lists the works reported on deep learning applied to ECG signals.

3.2.4. Deep learning methods applied to EOG and a combination of signals

The EOG measures the corneo-retinal standing potential which occurs between back and front of the human eye. Two electrodes are placed either left and right of the eye or above and below the eye. The signal can be used to detect eye movements [145]. It is useful for ophthalmological diagnosis [146]. However, the EOG is affected by noise and artifacts, that makes the signal interpretation difficult [147]. Table 5 details research work which aims to overcome these difficulties with deep learning algorithms. Only Zhu

Table 3

Summary of works carried out using DL algorithms with EEG signals.

Author	Application	DL algorithm	Data	Results
Fraiman et al., 2017 [81]	Sleep state identification	Autoencoders	Measurements [82]	80.4% accuracy
Schirmermeister et al., 2017 [83]	EEG decoding and visualization	CNN	BCI competition IV dataset 2a [84] and measurement data	Up 89.8% accuracy
Hosseini et al., 2017 [85]	Epileptogenicity localization	CNN	EEG and rs-fMRI measurements from the ECoG dataset [86]	Normal p-value 1.85e-14, p-Seizure value 4.64e-27
Schirmermeister et al., 2017 [87]	Decoding excited movements	CNN	Not reported	Accuracy comparable to standard methods
van Putten et al., 2017 [88]	Butcome prediction for patients with a postanoxic coma after cardiac arrest	CNN	EEGs from 287 patients at 12 h after cardiac arrest and 399 patients at 24 h after cardiac arrest	Sensitivity of 58% at a specificity of 100% for the prediction of poor outcome
Spampinato et al., 2017 [89]	Discriminate brain activity	CNN	Six subject were shown 2000 images in 4 sessions	Accuracy 86.9%
Kiral-Kornek et al., 2017 [90]	BCI	CNN	6 subjects up to 1000 individual hand squeezes	Power comparisons of various processing platforms.
Acharya et al., 2017 [91]	Seizure detection	CNN	Freiburg EEG DB [92–96]	accuracy: 88.67%
Lu et al., 2017 [97]	Motor imagery classification	RBM	BCI competition IV data set 2b [98–100]	Accuracy has been improved about 5% compared with other methods.
Huve et al., 2017 [80]	Tracking of neural dynamics	CNN, DNN	1 subject 180 trials	DNN outperforms CNN
Hajinorozi et al., 2016 [101]	Prediction of driver's cognitive performance	CNN	37 subjects, 70 sessions	Area under the receiver operating characteristic: 86.08
Nurse et al., 2016 [102]	BCI	CNN	1 subject 30 min of data	accuracy 81%
Jingwei et al., 2015 [103]	Response representation	CNN	EEG motor activity data set [104]	accuracy: 100%
Hajinorozi et al., 2015 [105]	Prediction of driver's cognitive performance	CNN	37 subjects, 80 sessions	Area under the receiver operating characteristic: 82.78
Jirayucharoensak et al., 2014 [106]	Based Emotion Recognition	Deep learning network	DEAP Dataset [107]	valence accuracy: 49.52%, arousal accuracy 46.03%
An et al., 2014 [108]	Based Emotion Recognition	Deep learning network	4 subjects 60 trials	valence accuracy: 49.52%, arousal accuracy 46.03%
Zheng et al., 2014 [109]	Emotion classification	DBN	6 subjects 2 trials each	accuracy: 87.62%
Li and Cichocki, 2014 [110]	Motor imagery	DBN	3 subjects performing motor imagery tasks in four sessions. Each session had 15 trails.	Accuracy: 96%
Jia et al., 2014 [111]	Affective state recognition	RBM	DEAP Dataset [107]	RBM-based model to extract representative features and to reduce the data dimensionality
Ren and Wu, 2014 [112]	Feature extraction	CNN	Dataset III in 2003 BCIC II, Dataset Iva in 2005 BCIC III, Dataset III in 2005 BCIC III [98–100]	Accuracy: 87.33%
Ahmed et al., 2013 [113]	Detecting target images	DBN	Not specified	DBN outperforms Support Vector Machine(SVM).
Mirowski et al., 2008 [114]	Epileptic seizure prediction	CNN	Freiburg EEG DB [92–96]	zero-false-alarm seizure prediction on 20 patients out of 21
Cecotti and Graeser, 2008 [115]	Motor imagery classification	CNN	2 subjects 5 trails of about 3 minutes	Recognition accuracy: 53.47%

et al. applied the deep leaning algorithm exclusively to EOG signals. Table 5 presents a summary of works carried out using DL algorithms with EOG and other physiological signals.

4. Discussion

Even though the deep learning is still in its infancy, published studies have shown that it possesses the capability of faster and more reliable diagnoses in physiological signals. That potency may well trigger a shift away from the currently used decision support methods, such as (SVM) and K-Nearest Neighbour(K-NN), towards deep learning [154]. It can noted from Table 4 that the employment of deep learning in ECG signals yielded promising diagnostic performances. This is because the developed model is able to capture the distinctive features from the ECG signals. Hence, the network can be trained from these learned features even without big data, achieving desirable diagnostic performance. On the other hand, the automated analysis of EMG and EEG signals is more challenging as these signals are more chaotic in nature. Therefore, it is more complicated for the network to learn from the hidden and subtle information present in these signals.

During the content review, we have studied the DL algorithm types used for their research works. Table 6 shows the number of studies that used a particular DL algorithm to analyse a specific physiological signals. CNN was used in 5, 15, 10 and 2 research

works on EMG, EEG, and ECG respectively. Overall, CNN was used 32 times, that makes it by far the most popular DL algorithm. At the bottom of the table is LSTM which was only used for ECG processing.

Apart from the algorithms, we have also studied the type of data used to conduct these studies. Table 7 indicates a summary of the data type used to implement the DL algorithm. Row one indicates that 28 studies were conducted using the public databases. Only 20 studies used private databases and 3 studies have used both databases. 16 out of 17 studies using ECG and 8 out of 23 studies on EEG have used public data. Indeed, 12 studies have used private EEG data to implement the deep learning algorithms.

Conventional machine learning approaches require lots of time and effort for feature selection. These features must extract relevant information from huge and diverse data in order to produce the best diagnostic performance. Furthermore, the best algorithm is unknown and thus, a lot of trial and error is necessary to select the best feature extraction algorithms and classification methods to develop a robust and reliable decision support systems for the physiological signals. On the other hand, deep learning eliminates the need for feature extraction and feature selection. The decision-making algorithm can consider all available evidence [155].

The training algorithms for deep leaning systems have a high computational complexity. Hence, this results in a high run-time complexity which translates into a long training time [156–158].

Table 4
Summary of works carried out using DL algorithms with ECG signals.

Author	Application	DL algorithm	Data	Results
Acharya et al., 2017 [124]	Arrhythmia detection using different intervals of tachycardia ECG segments	CNN	MIT-BIH arrhythmia database [125]	Accuracy of 92.50%, sensitivity of 98.09%, specificity of 93.13%
Tan et al., 2017 [126]	Coronary artery disease signal identification	LSTM, CNN	Physionet databases: Fantasia (for Normal) and St.-Petersburg Institute of Cardiology Technics (for CAD) [125]	Accuracy of 99.85%.
Acharya et al., 2017 [127]	Coronary artery disease detection	CNN	Physionet databases: Fantasia (for Normal) and St.-Petersburg Institute of Cardiology Technics (for CAD) [125]	Accuracy of 94.95% and 95.11% are obtained for two and five seconds ECG segments respectively.
Pourbabae et al., 2017 [128]	Features for Screening Paroxysmal Atrial Fibrillation	CNN	The PAF prediction challenge database [129]	Precision=93.6%
Zheng et al., 2017 [130]	ECG identification	DNN	MIT arrhythmia database [131] and self-collected data	94.39% recognition rate
Majumdar et al., 2017 [132]	Arrhythmia classification	Robust deep dictionary learning	MIT arrhythmia database [131]	97.0% recognition rate
Shashikumar et al., 2017 [133]	Monitoring and detecting atrial fibrillation	CNN	98 subjects, 45 with atrial fibrillation and 53 with other rhythms.	Up to 91.8% accuracy
Acharya et al., 2017 [123]	Detection of myocardial infarction	CNN	lead II from the ECG DB (Physikalisch-Technische Bundesanstalt diagnostic ECG DB) [125]	accuracy: 93.18%
Lou et al., 2017 [134]	Heartbeat classification	DNN	Lead II from the MIT-BIH arrhythmia DB [131]	Accuracy: 97.5%
Acharya et al., 2017 [135]	Identification of ventricular arrhythmias	CNN	MIT-BIH arrhythmia DB (MITDB) [125,131], MIT-BIH malignant ventricular arrhythmia DB (VFDB) [136], Creighton University ventricular tachyarrhythmia DB (CUDB) [137]	accuracy: 92.50%
Acharya et al., 2017 [138]	Heart beat classification	CNN	MIT-BIH arrhythmia DB [125]	accuracy: 94.03%
Cheng et al., 2017 [139]	Sleep apnea detection	RNN	ECG sleep apnea DB [140]	accuracy: ≈90%
Taji et al., 2017 [141]	Signal quality classification	RBM	MIT-BIH arrhythmia DB [125]	accuracy: 99.5%
Lou et al., 2017 [134]	Heartbeat classification	RBM	MIT-BIH arrhythmia DB [131]	RBM-based model to extract representative features and to reduce the data dimensionality
Muduli et al., 2017 [142]	Fetal-ECG signal reconstruction	Stacked Denoising Autoencoder	Abdominal non-invasive FECG DB [125]	accuracy: 99.5%
Kiranyaz et al., 2016 [143]	Heart beat classification	CNN	MIT-BIH arrhythmia DB [125]	accuracy: 99%
Zheng et al., 2014 [144]	Congestive heart failure detection	CNN	BIDMC Congestive Heart Failure data set [125]	accuracy: 94.67%

Table 5
Summary of works carried out using DL algorithms with EOG and other signals.

Author	Application	Signal	DL algorithm	Data	Results
Du et al., 2017 [148]	Driving fatigue detection	EOG and EEG	Autoencoder	Measurements from 21 subjects	Correlation Coefficient 0.85, Root Mean Square Error 0.09
Zhang et al., 2017 [149]	Momentary mental workload classification	EOG, EEG, ECG	CNN	6 subjects and 2 sessions each	Accuracy: 93.8%
Xia et al., 2017 [150]	Sleep stage classification	EOG, EEG	DBN	sleep EDF DB [Expanded] in Physionet [125,151]	Accuracy: 83.3%
Zhu et al., 2014 [152]	Drowsiness detection	EOG	CNN	22 subjects and 22 sessions each	mean correlation coefficient of 0.73
Långkvist et al., 2012 [153]	Sleep Stage Classification	EOG, EEG, EMG	DBN	25 acquisitions from PhysioNet [125] for training and testing and Home Sleep Dataset 60 hours from normal one subject for validation	72.2%

Table 6
Summary of various DL algorithms applied to different physiological signals.

DL algorithm	EMG	EEG	ECG	EOG	Total
CNN	5	15	10	2	32
DNN	2	1	2	0	5
DBN	0	3	0	2	5
RBM	0	2	2	0	4
Autoencoder	0	1	1	1	3
RNN	1	0	1	0	2
Deep learning network	0	2	0	0	2
Robust deep learning	0	0	1	0	1
LSTM	0	0	1	0	1

Table 7
Summary of data type used to implement the DL algorithm.

	EMG	EEG	ECG	EOG	Total
Publicly available databases	3	8	16	1	28
Private databases	4	12	1	3	20
Both	1	1	0	1	3
Not reported	0	2	0	0	2
Number of papers	8	23	17	5	53

This will be a problem during the design phase, because during this phase a designer must decide what deep learning architec-

ture to use. Once the architecture is chosen, the tuning parameters must be adjusted. Both the structure selection and parameter adjustment will basically influence the model. Hence, it is necessary to have many test runs. Shortening the training phase of deep learning models is an active area of research [159]. The challenge is speeding up the training process in a parallel distributed processing system [160]. The network between the individual processors becomes the bottle neck [161]. Graphics Processing Unit(GPUs) can be used to reduce the network latency [162].

For this state of the art technology, the training time may be an issue, because it can influence the model selection strategies. To be specific, none of the reviewed papers approached the model selection process with statistical methods, such as cross validation [163]. We can only assume that the deep learning architectures, used in the reviewed scientific work, were selected based on single run trial. Similarly, we have to assume that the hyperparameters were also optimized by training the network once. This is a serious shortcoming, because these statistical validation methods reduce the sample selection bias [164,165].

In addition, the use of deep learning can also be extended from one-dimensional physiological signals to two-dimensional medical images. Researchers are also exploring the benefits utilizing deep learning in medical image analyses [166]. It was reported that the automated staging and detection of Alzheimers disease, breast cancer, and lung cancer has shown optimistic diagnostic performances.

5. Conclusion

In this paper, we reviewed 53 papers on deep learning methods applied to healthcare applications based on physiological signals. The analysis was carried out in two distinct steps. The first step was bibliometric keyword analysis based on the co-occurrence map. This analysis step reveals the connection between the topics covered in the reviewed papers. We found four distinct clusters, one for each physiological signal. That result helped us to structure the second analysis step, which focuses on the paper content. As such, the paper content was established by extracting the specific application area, the deep learning algorithm, system performance, and the types of dataset used to develop the system.

The fact that deep learning algorithms performs well with large and diverse datasets which has two consequences. First, the dataset becomes critically important for the system design. Therefore, we focused our efforts on this criterion during our analysis. We found that, the scientific work, documented in 31 of the reviewed papers, was based on one or more freely available datasets. Therefore, we predict that the importance of these freely avail-

able public datasets may increase. The other consequence is that deep learning algorithms will perform well in practical settings, because clinical routine produces lots of data with large variations. However, none of the reviewed papers verified this in a practical setting. Another fundamental point is that, our literature survey yielded only 53 papers. The small number of studies imply that there is scope for future work. To be specific, 53 papers do not reflect the comprehensive healthcare applications based on the physiological signals. In future, there may be more advanced deep learning algorithms focused on the early detection of diseases using physiological signals.

Acknowledgements

Funding: No external funding sources supported this review.

Competing interests: The authors declare that they have no conflict of interest.

Statements of ethical approval: For this review article, the authors did not undertake work that involved human participants or animals.

Acronyms.

AED	Automated External Defibrillator
ANN	Artificial Neural Network
CNN	Convolutional Neural Network
CVD	Cardiovascular Disease
DB	Database
DBN	Deep Belief Network
DL	Deep Learning
DNN	Deep Neural Network
EKG	Electrocardiogram
EEG	Electroencephalogram
EMG	Electromyogram
EOG	Electrooculogram
GMM	Gaussian Mixture Model
GPU	Graphics Processing Unit
K-NN	K-Nearest Neighbour
LSTM	Long Short-Term Memory
OSA	Obstructive Sleep Apnea
RBM	Restricted Boltzmann Machine
RNN	Recurrent Neural Network
SVM	Support Vector Machine

Appendix A. Cluster description

Table A1
Author supplied keywords mapped to topics.

Topic	Author supplied keywords
arrhythmia	arrhythmia, arrhythmic signal identification
cvd	cardiovascular diseases, myocardial infarction, non-shockable, shockable, ventricular arrhythmias
db	mit-bih arrhythmia database, physiobank mit-bih arrhythmia database
dnn	deep neural network, deep neural networks
ecg	apnea- electrocardiogram signals, ecg, ecg measurement system, ecg signal, ecg signals, electrocardiogram, electrocardiogram signal quality classification, electrocardiogram signals, electrocardiography
heartbeat	heartbeat, heartbeat interval features, rr interval
measurement	computerised instrumentation, pollution measurement, power line interference
noise	denoising autoencoder, noise, noise measurement, snr
testing	testing
training	training, training data
wearable	wearable computers, wearable electrocardiogram measurement system, wearable fnirs
algorithm	ada-boost, algorithm, algorithms, classification algorithms, component analysis, compression, hidden markov models, independent component analysis
dbn	belief networks, boltzmann machines, convolutional deep belief networks, dbn, deep belief network, rbm, restricted boltzman machine RBM, restricted boltzmann machine, deep neural network, deep neural networks
eeg	brain signals, eeg, eeg data, eeg-based hand squeeze task, electroencephalography, electroencephalography (eeg), encephalogram signals
feature	feature clustering, feature extraction, feature learning, feature-extraction, features, unsupervised feature learning
learning	deep feature learning, deep learning, ensemble learning
machine	machine, machines
model	mathematical model, model, models
motor imagery	motor imagery
sleep	apnea detection, automatic sleep stage classification, obstructive sleep apnea detection, sleep apnea, sleep stage classification, slow eye-movements
classification	classification, emotion classification, patient-specific ecg classification, pattern classification
control	multifunction myoelectric control, myoelectric control
emg	electromyogram, electromyography, emg-based speech recognition, non-stationary emg, surface emg
ml	machine learning, machine learning algorithms
prostheses	prostheses, prosthetics, upper-limb, upper-limb prostheses
recognition	brain activity recognition, pattern recognition, pattern-recognition, recognition, signal recognition
signal	medical signal detection, medical signal processing, signal classification, signal reconstruction, signal representation, signals, time preserving signal representation strategy
bci	bci brain computer interface, brain computer interface (bci), brain computer interfaces, brain-computer interface, brain-computer interface (bci), brain-computer interfaces
cnn	cnn, convolution, convolution neural network, convolutional neural network, convolutional neural networks, convolutional neural networks (cnns)
epilepsy	epilepsy, seizure
nn	batch normalization layers, biological neural networks, feedforward neural nets, neural-networks, neurons
real-time	real-time, real-time heart monitoring, real-time systems, truenorth-enabled real-time classification
system	ibm truenorth neurosynaptic system, low-power platform, system

References

- [1] O. Faust, M.G. Bairy, Nonlinear analysis of physiological signals: a review, *J. Mech. Med. Biol.* 12 (04) (2012) 1240015.
- [2] D. Wang, Y. Shang, Modeling physiological data with deep belief networks, *Int. J. Inf. Educ. Technol. (IJJET)* 3 (5) (2013) 505.
- [3] H. Kantz, J. Kurths, G. Mayer-Kress, *Nonlinear Analysis of Physiological Data*, Springer Science & Business Media, 2012.
- [4] W. Van Drongelen, *Signal Processing for Neuroscientists: An Introduction to the Analysis of Physiological Signals*, Elsevier, 2006.
- [5] L. Sörnmo, P. Laguna, *Bioelectrical Signal Processing in Cardiac and Neurological Applications*, 8, Academic Press, 2005.
- [6] S.R. Devasahayam, *Signals and Systems in Biomedical Engineering: Signal Processing and Physiological Systems Modeling*, Springer Science & Business Media, 2012.
- [7] R. Miotto, F. Wang, S. Wang, X. Jiang, J.T. Dudley, Deep learning for healthcare: review, opportunities and challenges, *Brief. Bioinf.* (2017) bbx044.
- [8] K. Gödel, *On Formally Undecidable Propositions of Principia Mathematica and Related Systems*, Courier Corporation, 1992.
- [9] L.K. Morrell, F. Morrell, Evoked potentials and reaction times: a study of intra-individual variability, *Electroencephalogr. Clin. Neurophysiol.* 20 (6) (1966) 567–575.
- [10] B. Schijvenaars, Intra-individual variability of the electrocardiogram: assessment and exploitation in computerized ECG analysis, 2000.
- [11] O. Faust, E.Y. Ng, Computer aided diagnosis for cardiovascular diseases based on ecg signals: a survey, *J. Mech. Med. Biol.* 16 (01) (2016) 1640001.
- [12] E.A. Krupinski, K.S. Berbaum, R.T. Caldwell, K.M. Schartz, J. Kim, Long radiology workdays reduce detection and accommodation accuracy, *J. Am. Coll. Radiol.* 7 (9) (2010) 698–704.
- [13] T. Vertinsky, B. Forster, Prevalence of eye strain among radiologists: influence of viewing variables on symptoms, *Am. J. Roentgenol.* 184 (2) (2005) 681–686.
- [14] U.R. Acharya, O. Faust, S.V. Sree, D.N. Ghista, S. Dua, P. Joseph, V.T. Ahamed, N. Janarthanan, T. Tamura, An integrated diabetic index using heart rate variability signal features for diagnosis of diabetes, *Comput. Methods Biomech. Biomed. Eng.* 16 (2) (2013) 222–234.
- [15] A. Miller, B. Blott, et al., Review of neural network applications in medical imaging and signal processing, *Med. Biol. Eng. Comput.* 30 (5) (1992) 449–464.
- [16] O. Faust, W. Yu, N.A. Kadri, Computer-based identification of normal and alcoholic eeg signals using wavelet packets and energy measures, *J. Mech. Med. Biol.* 13 (03) (2013) 1350033.
- [17] O. Faust, U.R. Acharya, T. Tamura, Formal design methods for reliable computer-aided diagnosis: a review, *IEEE Rev. Biomed. Eng.* 5 (2012) 15–28.
- [18] K.Y. Zhi, O. Faust, W. Yu, Wavelet based machine learning techniques for electrocardiogram signal analysis, *J. Med. Imaging Health Inf.* 4 (5) (2014) 737–742.
- [19] U.R. Acharya, E.C.-P. Chua, O. Faust, T.-C. Lim, L.F.B. Lim, Automated detection of sleep apnea from electrocardiogram signals using nonlinear parameters, *Physiol. Meas.* 32 (3) (2011) 287.
- [20] O. Faust, U.R. Acharya, E. Ng, H. Fujita, A review of ecg-based diagnosis support systems for obstructive sleep apnea, *J. Mech. Med. Biol.* 16 (01) (2016) 1640004.
- [21] O. Faust, U.R. Acharya, H. Adeli, A. Adeli, Wavelet-based eeg processing for computer-aided seizure detection and epilepsy diagnosis, *Seizure* 26 (2015) 56–64.
- [22] O. Faust, U.R. Acharya, V.K. Sudarshan, R. San Tan, C.H. Yeong, F. Molinari, K.H. Ng, Computer aided diagnosis of coronary artery disease, myocardial infarction and carotid atherosclerosis using ultrasound images: a review, *Phys. Med.* 33 (2017) 1–15.
- [23] R. Rao, R. Derakhshani, A comparison of eeg preprocessing methods using time delay neural networks, in: *Neural Engineering, 2005. Conference Proceedings. 2nd International IEEE EMBS Conference on, IEEE, 2005*, pp. 262–264.
- [24] T. Kalayci, O. Ozdamar, Wavelet preprocessing for automated neural network detection of eeg spikes, *IEEE Eng. Med. Biol. Mag.* 14 (2) (1995) 160–166.
- [25] R. Kohavi, G.H. John, Wrappers for feature subset selection, *Artif. Intell.* 97 (1–2) (1997) 273–324.

- [26] M.A. Hall, Correlation-based feature selection for machine learning, 1999.
- [27] O. Faust, U.R. Acharya, E. Ng, T.J. Hong, W. Yu, Application of infrared thermography in computer aided diagnosis, *Infrared Phys. Technol.* 66 (2014) 160–175.
- [28] H. Yoon, K. Yang, C. Shahabi, Feature subset selection and feature ranking for multivariate time series, *IEEE Trans. Knowl. Data Eng.* 17 (9) (2005) 1186–1198.
- [29] H. Liu, H. Motoda, *Computational Methods of Feature Selection*, CRC Press, 2007.
- [30] Y. Bengio, A.C. Courville, P. Vincent, Unsupervised feature learning and deep learning: a review and new perspectives, *CoRR*, abs/1206.5538 1(2012).
- [31] Y. LeCun, Y. Bengio, G. Hinton, Deep learning, *Nature* 521 (7553) (2015) 436–444.
- [32] N.Z.N. Jenny, O. Faust, W. Yu, Automated classification of normal and premature ventricular contractions in electrocardiogram signals, *J. Med. Imaging Health Inf.* 4 (6) (2014) 886–892.
- [33] O. Faust, L.M. Yi, L.M. Hua, Heart rate variability analysis for different age and gender, *J. Med. Imaging Health Inf.* 3 (3) (2013) 395–400.
- [34] P.D. McAndrew, D.L. Potash, B. Higgins, J. Wayand, J. Held, Expert system for providing interactive assistance in solving problems such as health care management, 1996, US Patent 5,517,405.
- [35] M. Långkvist, L. Karlsson, A. Loutfi, A review of unsupervised feature learning and deep learning for time-series modeling, *Pattern Recognit. Lett.* 42 (2014) 11–24.
- [36] Y. Bengio, O. Delalleau, On the expressive power of deep architectures, in: *Algorithmic Learning Theory*, Springer, 2011, pp. 18–36.
- [37] I. Goodfellow, Y. Bengio, A. Courville, *Deep Learning*, MIT press, 2016.
- [38] L. Squire, D. Berg, F.E. Bloom, S. Du Lac, A. Ghosh, N.C. Spitzer, *Fundamental Neuroscience*, Academic Press, 2012.
- [39] K. Fukushima, S. Miyake, Neocognitron: a self-organizing neural network model for a mechanism of visual pattern recognition, in: *Competition and cooperation in neural nets*, Springer, 1982, pp. 267–285.
- [40] Y. LeCun, L. Bottou, Y. Bengio, P. Haffner, Gradient-based learning applied to document recognition, *Proc. IEEE* 86 (11) (1998) 2278–2324.
- [41] Y. LeCun, Y. Bengio, et al., Convolutional networks for images, speech, and time series, *Handb. Brain Theory Neural Netw.* 3361 (10) (1995) 1995.
- [42] K. He, X. Zhang, S. Ren, J. Sun, Delving deep into rectifiers: surpassing human-level performance on imagenet classification, in: *Proceedings of the IEEE International Conference on Computer Vision*, 2015, pp. 1026–1034.
- [43] J. Bouvrie, *Notes on convolutional neural networks*, 2006.
- [44] G.E. Hinton, R.R. Salakhutdinov, Reducing the dimensionality of data with neural networks, *Science* 313 (5786) (2006) 504–507.
- [45] G.E. Hinton, S. Osindero, Y.-W. Teh, A fast learning algorithm for deep belief nets, *Neural Comput.* 18 (7) (2006) 1527–1554.
- [46] D.P. Kingma, S. Mohamed, D.J. Rezende, M. Welling, Semi-supervised learning with deep generative models, in: *Advances in Neural Information Processing Systems*, 2014, 2014, pp. 3581–3589.
- [47] J.J. Hopfield, Neural networks and physical systems with emergent collective computational abilities, in: *Spin Glass Theory and Beyond: An Introduction to the Replica Method and Its Applications*, World Scientific, 1987, pp. 411–415.
- [48] H. Larochelle, M. Mandel, R. Pascanu, Y. Bengio, Learning algorithms for the classification restricted boltzmann machine, *J. Mach. Learn. Res.* 13 (Mar) (2012) 643–669.
- [49] P. Smolensky, *Information Processing in Dynamical Systems: Foundations of Harmony Theory*, Technical Report, Colorado Univ at Boulder Dept of Computer Science, 1986.
- [50] R. Salakhutdinov, *Learning Deep Generative Models*, University of Toronto, 2009.
- [51] Y. Bengio, P. Lamblin, D. Popovici, H. Larochelle, Greedy layer-wise training of deep networks, in: *Advances in Neural Information Processing Systems*, 2007, pp. 153–160.
- [52] S. Hochreiter, J. Schmidhuber, Long short-term memory, *Neural Comput.* 9 (8) (1997) 1735–1780.
- [53] H. Anton, I. Bivens, S. Davis, *Calculus*, 2, Wiley Hoboken, 2002.
- [54] M.H. Kutner, C. Nachtsheim, J. Neter, *Applied Linear Regression Models*, McGraw-Hill/Irwin, 2004.
- [55] N.J. van Eck, L. Waltman, Visualizing bibliometric networks, in: *Measuring Scholarly Impact*, Springer, 2014, pp. 285–320.
- [56] L. Waltman, N.J. van Eck, E.C. Noyons, A unified approach to mapping and clustering of bibliometric networks, *J. Informetr.* 4 (4) (2010) 629–635.
- [57] J.V. Basmajian, C. De Luca, *Muscles alive*, in: *Muscles Alive: Their Functions Revealed by Electromyography*, 278, Lloyd-Luke Medical Books, 1985, p. 126.
- [58] C.J. De Luca, The use of surface electromyography in biomechanics, *J. Appl. Biomech.* 13 (2) (1997) 135–163.
- [59] C. De Luca, Myoelectric manifestation of localized muscular fatigue in humans, *IEEE Transactions on Biomedical Engineering*, 30, IEEE-INST Electrical Electronics Engineers Inc, 445 Hoes Lane, Piscataway, NJ 08855 USA, 1983, 531–531.
- [60] P. Xia, J. Hu, Y. Peng, Emg-based estimation of limb movement using deep learning with recurrent convolutional neural networks, *Artif. Organs* (2017).
- [61] X. Zhai, B. Jelfs, R.H. Chan, C. Tin, Self-recalibrating surface emg pattern recognition for neuroprostheses control based on convolutional neural network, *Front. Neurosci.* 11 (2017) 379.
- [62] M. Atzori, A. Gijsberts, C. Castellini, B. Caputo, A.-G.M. Hager, S. Elsig, G. Giatsidis, F. Bassetto, H. Müller, Electromyography data for non-invasive natural-ly-controlled robotic hand prostheses, *Sci. Data* 1 (2014) 140053.
- [63] K.-H. Park, S.-W. Lee, Movement intention decoding based on deep learning for multiuser myoelectric interfaces, in: *Brain-Computer Interface BCI*, 2016 4th International Winter Conference on, IEEE, 2016, pp. 1–2.
- [64] M. Atzori, A. Gijsberts, I. Kuzborskij, S. Elsig, A.-G.M. Hager, O. Deriaz, C. Castellini, H. Müller, B. Caputo, Characterization of a benchmark database for myoelectric movement classification, *IEEE Trans. Neural Syst. Rehabil. Eng.* 23 (1) (2015) 73–83.
- [65] M. Atzori, M. Cognolato, H. Müller, Deep learning with convolutional neural networks applied to electromyography data: a resource for the classification of movements for prosthetic hands, *Front. Neurobot.* 10 (2016).
- [66] W. Geng, Y. Du, W. Jin, W. Wei, Y. Hu, J. Li, Gesture recognition by instantaneous surface emg images, *Sci. Rep.* 6 (2016) 36571.
- [67] M. Wand, J. Schmidhuber, Deep neural network frontend for continuous emg-based speech recognition, in: *INTERSPEECH*, 2016, pp. 3032–3036.
- [68] M. Wand, M. Janke, T. Schultz, The emg-uka corpus for electromyographic speech processing, in: *Fifteenth Annual Conference of the International Speech Communication Association*, 2014, pp. 1593–1597.
- [69] U.C. Allard, F. Nougrou, C.L. Fall, P. Giguère, C. Gosselin, F. Laviolette, B. Gosselin, A convolutional neural network for robotic arm guidance using semg based frequency-features, in: *Intelligent Robots and Systems (IROS)*, 2016 IEEE/RSJ International Conference on, IEEE, 2016, pp. 2464–2470.
- [70] M. Wand, T. Schultz, Pattern learning with deep neural networks in emg-based speech recognition, in: *Engineering in Medicine and Biology Society (EMBC)*, 2014 36th Annual International Conference of the IEEE, IEEE, 2014, pp. 4200–4203.
- [71] Q. Liu, K. Chen, Q. Ai, S.Q. Xie, Recent development of signal processing algorithms for ssvep-based brain computer interfaces, *J. Med. Biol. Eng.* 34 (4) (2014) 299–309.
- [72] Y.-F. Chen, K. Atal, S. Xie, Q. Liu, A new multivariate empirical mode decomposition method for improving the performance of ssvep-based brain computer interface, *J. Neural Eng.* (2017).
- [73] T.-P. Jung, S. Makeig, M. Westerfield, J. Townsend, E. Courchesne, T.J. Sejnowski, Removal of eye activity artifacts from visual event-related potentials in normal and clinical subjects, *Clin. Neurophysiol.* 111 (10) (2000) 1745–1758.
- [74] A. Schlögl, C. Keinrath, D. Zimmermann, R. Scherer, R. Leeb, G. Pfurtscheller, A fully automated correction method of eeg artifacts in eeg recordings, *Clin. Neurophysiol.* 118 (1) (2007) 98–104.
- [75] D. Moretti, F. Babiloni, F. Carducci, F. Cincotti, E. Remondini, P. Rossini, S. Salinari, C. Babiloni, Computerized processing of eeg-eog-emg artifacts for multi-centric studies in eeg oscillations and event-related potentials, *Int. J. Psychophysiol.* 47 (3) (2003) 199–216.
- [76] S. Xing, R. McCordle, S. Xie, The development of eeg-based brain computer interfaces: potential and challenges, *Int. J. Comput. Appl. Technol.* 50 (1–2) (2014) 84–98.
- [77] J.R. Wolpaw, D.J. McFarland, G.W. Neat, C.A. Forneris, An eeg-based brain-computer interface for cursor control, *Electroencephalogr. Clin. Neurophysiol.* 78 (3) (1991) 252–259.
- [78] C. Guger, H. Ramoser, G. Pfurtscheller, Real-time eeg analysis with subject-specific spatial patterns for a brain-computer interface (bci), *IEEE Trans. Rehabil. Eng.* 8 (4) (2000) 447–456.
- [79] S.C. Bunce, M. Izzetoglu, K. Izzetoglu, B. Onaral, K. Pourrezaei, Functional near-infrared spectroscopy, *IEEE Eng. Med. Biol. Mag.* 25 (4) (2006) 54–62.
- [80] G. Huve, K. Takahashi, M. Hashimoto, Brain activity recognition with a wearable fnirs using neural networks, in: *Mechatronics and Automation (ICMA)*, 2017 IEEE International Conference on, IEEE, 2017, pp. 1573–1578.
- [81] L. Fraiwan, K. Lweesy, Neonatal sleep state identification using deep learning autoencoders, in: *Signal Processing & its Applications (CSPA)*, 2017 IEEE 13th International Colloquium on, IEEE, 2017, pp. 228–231.
- [82] A. Piryatinska, G. Terdik, W.A. Woyczynski, K.A. Loparo, M.S. Scher, A. Zlotnik, Automated detection of neonate eeg sleep stages, *Comput. Methods Programs Biomed.* 95 (1) (2009) 31–46.
- [83] R.T. Schirrmester, J.T. Springenberg, L.D.J. Fiederer, M. Glasstetter, K. Eggensperger, M. Tangermann, F. Hutter, W. Burgard, T. Ball, Deep learning with convolutional neural networks for eeg decoding and visualization, *Hum. Brain Mapp.* 38 (11) (2017) 5391–5420.
- [84] C. Brunner, R. Leeb, G. Müller-Putz, A. Schlögl, G. Pfurtscheller, Bci Competition 2008–Graz Data Set A, 16, Institute for Knowledge Discovery (Laboratory of Brain-Computer Interfaces), Graz University of Technology, 2008.
- [85] M.-P. Hosseini, T.X. Tran, D. Pompili, K. Elisevich, H. Soltanian-Zadeh, Deep learning with edge computing for localization of epileptogenicity using multimodal rs-fmri and eeg big data, in: *Autonomic Computing (ICAC)*, 2017 IEEE International Conference on, IEEE, 2017, pp. 83–92.
- [86] M. Stead, M. Bower, B.H. Brinkmann, K. Lee, W.R. Marsh, F.B. Meyer, B. Litt, J. Van Gompel, G.A. Worrell, Microseizures and the spatiotemporal scales of human partial epilepsy, *Brain* 133 (9) (2010) 2789–2797.
- [87] R.T. Schirrmester, L.D.J. Fiederer, J.T. Springenberg, M. Glasstetter, K. Eggensperger, M. Tangermann, F. Hutter, W. Burgard, T. Ball, Designing and understanding convolutional networks for decoding executed movements from eeg, in: *The First Biannual Neuroadaptive Technology Conference*, 2017, p. 143.
- [88] M.J. van Putten, J. Hofmeijer, B.J. Ruijter, M.C. Tjepkema-Cloostermans, Deep learning for outcome prediction of postanoxic coma, in: *EMBE & NBC 2017*, Springer, 2017, pp. 506–509.
- [89] C. Spampinato, S. Palazzo, I. Kavasidis, D. Giordano, N. Souly, M. Shah, Deep learning human mind for automated visual classification, in: *2017 IEEE Con-*

- ference on Computer Vision and Pattern Recognition (CVPR), 2017, pp. 4503–4511, doi:10.1109/CVPR.2017.479.
- [90] I. Kiral-Kornek, D. Mendis, E.S. Nurse, B.S. Mashford, D.R. Freestone, D.B. Grayden, S. Harrer, Truenorth-enabled real-time classification of eeg data for brain-computer interfacing, in: Engineering in Medicine and Biology Society (EMBC), 2017 39th Annual International Conference of the IEEE, IEEE, 2017, pp. 1648–1651.
- [91] U.R. Acharya, S.L. Oh, Y. Hagiwara, J.H. Tan, H. Adeli, Deep convolutional neural network for the automated detection and diagnosis of seizure using eeg signals, *Comput. Biol. Med.* (2017).
- [92] M. Winterhalder, T. Maiwald, H. Voss, R. Aschenbrenner-Scheibe, J. Timmer, A. Schulze-Bonhage, The seizure prediction characteristic: a general framework to assess and compare seizure prediction methods, *Epilepsy Behav.* 4 (3) (2003) 318–325.
- [93] R. Aschenbrenner-Scheibe, T. Maiwald, M. Winterhalder, H. Voss, J. Timmer, A. Schulze-Bonhage, How well can epileptic seizures be predicted? An evaluation of a nonlinear method, *Brain* 126 (12) (2003) 2616–2626.
- [94] T. Maiwald, M. Winterhalder, R. Aschenbrenner-Scheibe, H.U. Voss, A. Schulze-Bonhage, J. Timmer, Comparison of three nonlinear seizure prediction methods by means of the seizure prediction characteristic, *Physica D* 194 (3) (2004) 357–368.
- [95] B. Schelter, M. Winterhalder, T. Maiwald, A. Brandt, A. Schad, A. Schulze-Bonhage, J. Timmer, Testing statistical significance of multivariate time series analysis techniques for epileptic seizure prediction, *Chaos Interdiscip. J. Non-linear Sci.* 16 (1) (2006) 013108.
- [96] B. Schelter, M. Winterhalder, T. Maiwald, A. Brandt, A. Schad, J. Timmer, A. Schulze-Bonhage, Do false predictions of seizures depend on the state of vigilance? a report from two seizure-prediction methods and proposed remedies, *Epilepsia* 47 (12) (2006) 2058–2070.
- [97] N. Lu, T. Li, X. Ren, H. Miao, A deep learning scheme for motor imagery classification based on restricted boltzmann machines, *IEEE Trans. Neural Syst. Rehabil. Eng.* 25 (6) (2017) 566–576.
- [98] R. Leeb, F. Lee, C. Keinrath, R. Scherer, H. Bischof, G. Pfurtscheller, Brain-computer communication: motivation, aim, and impact of exploring a virtual apartment, *IEEE Trans. Neural Syst. Rehabil. Eng.* 15 (4) (2007) 473–482.
- [99] P. Sajda, A. Gerson, K.-R. Muller, B. Blankertz, L. Parra, A data analysis competition to evaluate machine learning algorithms for use in brain-computer interfaces, *IEEE Trans. Neural Syst. Rehabil. Eng.* 11 (2) (2003) 184–185.
- [100] B. Blankertz, K.-R. Muller, G. Curio, T.M. Vaughan, G. Schalk, J.R. Wolpaw, A. Schlögl, C. Neuper, G. Pfurtscheller, T. Hinterberger, et al., The bci competition 2003: progress and perspectives in detection and discrimination of eeg single trials, *IEEE Trans. Biomed. Eng.* 51 (6) (2004) 1044–1051.
- [101] M. Hajinorozi, Z. Mao, T.-P. Jung, C.-T. Lin, Y. Huang, Eeg-based prediction of driver's cognitive performance by deep convolutional neural network, *Signal Process. Image Commun.* 47 (2016) 549–555.
- [102] E. Nurse, B.S. Mashford, A.J. Yepes, I. Kiral-Kornek, S. Harrer, D.R. Freestone, Decoding eeg and lfp signals using deep learning: heading truenorth, in: Proceedings of the ACM International Conference on Computing Frontiers, ACM, 2016, pp. 259–266.
- [103] L. Jingwei, C. Yin, Z. Weidong, Deep learning eeg response representation for brain computer interface, in: Control Conference (CCC), 2015 34th Chinese, IEEE, 2015, pp. 3518–3523.
- [104] H. Piroška, S. Janos, Specific movement detection in eeg signal using time-frequency analysis, in: Complexity and Intelligence of the Artificial and Natural Complex Systems, Medical Applications of the Complex Systems, Biomedical Computing, 2008. CANS'08. First International Conference on, IEEE, 2008, pp. 209–215.
- [105] M. Hajinorozi, Z. Mao, Y. Huang, Prediction of driver's drowsy and alert states from eeg signals with deep learning, in: Computational Advances in Multi-Sensor Adaptive Processing (CAMSAP), 2015 IEEE 6th International Workshop on, IEEE, 2015, pp. 493–496.
- [106] S. Jirayucharoensak, S. Pan-Ngum, P. Israsena, Eeg-based emotion recognition using deep learning network with principal component based covariate shift adaptation, *Sci. World J.* 2014 (2014).
- [107] S. Koelstra, C. Muhl, M. Soleymani, J.-S. Lee, A. Yazdani, T. Ebrahimi, T. Pun, A. Nijholt, I. Patras, Deap: a database for emotion analysis; using physiological signals, *IEEE Trans. Affect. Comput.* 3 (1) (2012) 18–31.
- [108] X. An, D. Kuang, X. Guo, Y. Zhao, L. He, A deep learning method for classification of eeg data based on motor imagery, in: International Conference on Intelligent Computing, Springer, 2014, pp. 203–210.
- [109] W.-L. Zheng, J.-Y. Zhu, Y. Peng, B.-L. Lu, Eeg-based emotion classification using deep belief networks, in: Multimedia and Expo (ICME), 2014 IEEE International Conference on, IEEE, 2014, pp. 1–6.
- [110] J. Li, A. Cichocki, Deep learning of multifractal attributes from motor imagery induced eeg, in: International Conference on Neural Information Processing, Springer, 2014, pp. 503–510.
- [111] X. Jia, K. Li, X. Li, A. Zhang, A novel semi-supervised deep learning framework for affective state recognition on eeg signals, in: Bioinformatics and Bioengineering (BIBE), 2014 IEEE International Conference on, IEEE, 2014, pp. 30–37.
- [112] Y. Ren, Y. Wu, Convolutional deep belief networks for feature extraction of eeg signal, in: Neural Networks (IJCNN), 2014 International Joint Conference on, IEEE, 2014, pp. 2850–2853.
- [113] S. Ahmed, L.M. Merino, Z. Mao, J. Meng, K. Robbins, Y. Huang, A deep learning method for classification of images rsvp events with eeg data, in: Global Conference on Signal and Information Processing (GlobalSIP), 2013 IEEE, IEEE, 2013, pp. 33–36.
- [114] P.W. Mirowski, Y. LeCun, D. Madhavan, R. Kuzniecky, Comparing svm and convolutional networks for epileptic seizure prediction from intracranial eeg, in: Machine Learning for Signal Processing, 2008. MLSP 2008. IEEE Workshop on, IEEE, 2008, pp. 244–249.
- [115] H. Cecotti, A. Graeser, Convolutional neural network with embedded fourier transform for eeg classification, in: Pattern Recognition, 2008. ICPR 2008. 19th International Conference on, IEEE, 2008, pp. 1–4.
- [116] P.R. Jeffries, S. Woolf, B. Linde, Technology-based vs. traditional instruction: a comparison of two methods for teaching the skill of performing a 12-lead eeg, *Nurs. Educ. Perspect.* 24 (2) (2003) 70–74.
- [117] A.D. Waller, A demonstration on man of electromotive changes accompanying the heart's beat, *J. Physiol.* 8 (5) (1887) 229–234.
- [118] U.R. Acharya, O. Faust, V. Sree, G. Swapna, R.J. Martis, N.A. Kadri, J.S. Suri, Linear and nonlinear analysis of normal and cad-affected heart rate signals, *Comput. Methods Programs Biomed.* 113 (1) (2014) 55–68.
- [119] U.R. Acharya, D.N. Ghista, Z. KuanYi, L.C. Min, E. Ng, S.V. Sree, O. Faust, L. Weidong, A. Alvin, Integrated index for cardiac arrhythmias diagnosis using entropies as features of heart rate variability signal, in: Biomedical Engineering (MECBME), 2011 1st Middle East Conference on, IEEE, 2011, pp. 371–374.
- [120] U.R. Acharya, O. Faust, N.A. Kadri, J.S. Suri, W. Yu, Automated identification of normal and diabetes heart rate signals using nonlinear measures, *Comput. Biol. Med.* 43 (10) (2013) 1523–1529.
- [121] O. Faust, V.R. Prasad, G. Swapna, S. Chattopadhyay, T.-C. Lim, Comprehensive analysis of normal and diabetic heart rate signals: a review, *J. Mech. Med. Biol.* 12 (05) (2012) 1240033.
- [122] P. De Chazal, M. O'Dwyer, R.B. Reilly, Automatic classification of heartbeats using eeg morphology and heartbeat interval features, *IEEE Trans. Biomed. Eng.* 51 (7) (2004) 1196–1206.
- [123] U.R. Acharya, H. Fujita, S.L. Oh, Y. Hagiwara, J.H. Tan, M. Adam, Application of deep convolutional neural network for automated detection of myocardial infarction using eeg signals, *Inf. Sci.* 415 (2017) 190–198.
- [124] U.R. Acharya, H. Fujita, O.S. Lih, Y. Hagiwara, J.H. Tan, M. Adam, Automated detection of arrhythmias using different intervals of tachycardia eeg segments with convolutional neural network, *Inf. Sci.* 405 (2017) 81–90.
- [125] A.L. Goldberger, L.A. Amaral, L. Glass, J.M. Hausdorff, P.C. Ivanov, R.G. Mark, J.E. Mietus, G.B. Moody, C.-K. Peng, H.E. Stanley, Physiobank, physiotoolkit, and physionet, *Circulation* 101 (23) (2000) e215–e220.
- [126] J.H. Tan, Y. Hagiwara, W. Pang, I. Lim, S.L. Oh, M. Adam, R. San Tan, M. Chen, U.R. Acharya, Application of stacked convolutional and long short-term memory network for accurate identification of cad eeg signals, *Comput. Biol. Med.* (2018).
- [127] U.R. Acharya, H. Fujita, S.L. Oh, U. Raghavendra, J.H. Tan, M. Adam, A. Gertych, Y. Hagiwara, Automated identification of shockable and non-shockable life-threatening ventricular arrhythmias using convolutional neural network, *Future Gener. Comput. Syst.* (2017).
- [128] B. Pourbabaee, M.J. Roshtkhari, K. Khorasani, Deep convolutional neural networks and learning eeg features for screening paroxysmal atrial fibrillation patients, *IEEE Trans. Syst. Man Cybern. Syst.* (2017).
- [129] G. Moody, A. Goldberger, S. McClennen, S. Swiryn, Predicting the onset of paroxysmal atrial fibrillation: The computers in cardiology challenge 2001, in: Computers in Cardiology 2001, IEEE, 2001, pp. 113–116.
- [130] G. Zheng, S. Ji, M. Dai, Y. Sun, Ecg based identification by deep learning, in: Chinese Conference on Biometric Recognition, Springer, 2017, pp. 503–510.
- [131] G.B. Moody, R.G. Mark, The impact of the mit-bih arrhythmia database, *IEEE Eng. Med. Biol. Mag.* 20 (3) (2001) 45–50.
- [132] A. Majumdar, R. Ward, Robust greedy deep dictionary learning for eeg arrhythmia classification, in: Neural Networks (IJCNN), 2017 International Joint Conference on, IEEE, 2017, pp. 4400–4407.
- [133] S.P. Shashikumar, A.J. Shah, Q. Li, G.D. Clifford, S. Nemati, A deep learning approach to monitoring and detecting atrial fibrillation using wearable technology, in: Biomedical & Health Informatics (BHI), 2017 IEEE EMBS International Conference on, IEEE, 2017, pp. 141–144.
- [134] K. Luo, J. Li, Z. Wang, A. Cuschieri, Patient-specific deep architectural model for eeg classification, *J. Healthcare Eng.* 2017 (2017).
- [135] U.R. Acharya, H. Fujita, M. Adam, O.S. Lih, V.K. Sudarshan, T.J. Hong, J.E. Koh, Y. Hagiwara, C.K. Chua, C.K. Poo, et al., Automated characterization and classification of coronary artery disease and myocardial infarction by decomposition of eeg signals: a comparative study, *Inf. Sci.* 377 (2017) 17–29.
- [136] S.D. Greenwald, The Development and Analysis of a Ventricular Fibrillation Detector, Massachusetts Institute of Technology, 1986 Ph.D. thesis.
- [137] F.M. Nolle, F.K. Badura, J.M. Catlett, R.W. Bowser, S.M. H. Crei-gard, a new concept in computerized arrhythmia monitoring systems, *Comput. Cardiol.* 63 (1986) 515–518.
- [138] U.R. Acharya, S.L. Oh, Y. Hagiwara, J.H. Tan, M. Adam, A. Gertych, R. San Tan, A deep convolutional neural network model to classify heartbeats, *Comput. Biol. Med.* 89 (2017) 389–396.
- [139] M. Cheng, W.J. Sori, F. Jiang, A. Khan, S. Liu, Recurrent neural network based classification of eeg signal features for obstruction of sleep apnea detection, in: Computational Science and Engineering (CSE) and Embedded and Ubiquitous Computing (EUC), 2017 IEEE International Conference on, IEEE, 2017, pp. 199–202.
- [140] T. Penzel, G.B. Moody, R.G. Mark, A.L. Goldberger, J.H. Peter, The apnea-ecg database, in: Computers in Cardiology 2000, IEEE, 2000, pp. 255–258.
- [141] B. Taji, A.D. Chan, S. Shirmohammadi, Classifying measured electrocardiogram signal quality using deep belief networks, in: Instrumentation and Measure-

- ment Technology Conference (I2MTC), 2017 IEEE International, IEEE, 2017, pp. 1–6.
- [142] P.R. Muduli, R.R. Gunukula, A. Mukherjee, A deep learning approach to fetal-ecg signal reconstruction, in: Communication (NCC), 2016 Twenty Second National Conference on, IEEE, 2016, pp. 1–6.
- [143] S. Kiranyaz, T. Ince, M. Gabbouj, Real-time patient-specific ecg classification by 1-d convolutional neural networks, *IEEE Trans. Biomed. Eng.* 63 (3) (2016) 664–675.
- [144] Y. Zheng, Q. Liu, E. Chen, Y. Ge, J.L. Zhao, Time series classification using multi-channels deep convolutional neural networks, in: International Conference on Web-Age Information Management, Springer, 2014, pp. 298–310.
- [145] A. Bulling, J.A. Ward, H. Gellersen, G. Troster, Eye movement analysis for activity recognition using electrooculography, *IEEE Trans. Pattern Anal. Mach. Intell.* 33 (4) (2011) 741–753.
- [146] R. Barea, L. Boquete, M. Mazo, E. López, System for assisted mobility using eye movements based on electrooculography, *IEEE Trans. Neural Syst. Rehabil. Eng.* 10 (4) (2002) 209–218.
- [147] A.R. Kherlopian, J.P. Gerrein, M. Yue, K.E. Kim, J.W. Kim, M. Sukumaran, P. Sajda, Electrooculogram based system for computer control using a multiple feature classification model, in: Engineering in Medicine and Biology Society, 2006. EMBS'06. 28th Annual International Conference of the IEEE, IEEE, 2006, pp. 1295–1298.
- [148] L.-H. Du, W. Liu, W.-L. Zheng, B.-L. Lu, Detecting driving fatigue with multimodal deep learning, in: Neural Engineering (NER), 2017 8th International IEEE/EMBS Conference on, IEEE, 2017, pp. 74–77.
- [149] J. Zhang, S. Li, R. Wang, Pattern recognition of momentary mental workload based on multi-channel electrophysiological data and ensemble convolutional neural networks, *Front. Neurosci.* 11 (2017).
- [150] B. Xia, Q. Li, J. Jia, J. Wang, U. Chaudhary, A. Ramos-Murguialday, N. Birbaumer, Electrooculogram based sleep stage classification using deep belief network, in: Neural Networks (IJCNN), 2015 International Joint Conference on, IEEE, 2015, pp. 1–5.
- [151] B. Kemp, A.H. Zwinderman, B. Tuk, H.A. Kamphuisen, J.J. Obery, Analysis of a sleep-dependent neuronal feedback loop: the slow-wave microcontinuity of the eeg, *IEEE Trans. Biomed. Eng.* 47 (9) (2000) 1185–1194.
- [152] X. Zhu, W.-L. Zheng, B.-L. Lu, X. Chen, S. Chen, C. Wang, Eog-based drowsiness detection using convolutional neural networks., in: IJCNN, 2014, pp. 128–134.
- [153] M. Långkvist, L. Karlsson, A. Loutfi, Sleep stage classification using unsupervised feature learning, *Adv. Artif. Neural Syst.* 2012 (2012) 5.
- [154] O. Faust, Documenting and predicting topic changes in computers in biology and medicine: a bibliometric keyword analysis from 1990 to 2017, *Inf. Med. Unlocked* 11 (2018) 15–27, doi:10.1016/j.imu.2018.03.002.
- [155] S. Min, B. Lee, S. Yoon, Deep learning in bioinformatics, *Brief. Bioinf.* (2016) bbw068.
- [156] J. Dean, G. Corrado, R. Monga, K. Chen, M. Devin, M. Mao, A. Senior, P. Tucker, K. Yang, Q.V. Le, et al., Large scale distributed deep networks, in: Advances in Neural Information Processing Systems, 2012, pp. 1223–1231.
- [157] S. Tokui, K. Oono, S. Hido, J. Clayton, Chainer: a next-generation open source framework for deep learning, in: Proceedings of Workshop on Machine Learning Systems (LearningSys) in the Twenty-Ninth Annual Conference on Neural Information Processing Systems (NIPS), 5, 2015, pp. 1–6.
- [158] K. Chatfield, K. Simonyan, A. Vedaldi, A. Zisserman, Return of the devil in the details: delving deep into convolutional nets, [arXiv:1405.3531](https://arxiv.org/abs/1405.3531)(2014).
- [159] D. Erhan, Y. Bengio, A. Courville, P.-A. Manzagol, P. Vincent, S. Bengio, Why does unsupervised pre-training help deep learning? *J. Mach. Learn. Res.* 11 (Feb) (2010) 625–660.
- [160] X.-W. Chen, X. Lin, Big data deep learning: challenges and perspectives, *IEEE Access* 2 (2014) 514–525.
- [161] M.M. Najafabadi, F. Villanustre, T.M. Khoshgoftaar, N. Seliya, R. Wald, E. Muharemagic, Deep learning applications and challenges in big data analytics, *J. Big Data* 2 (1) (2015) 1.
- [162] J. Bergstra, F. Bastien, O. Breuleux, P. Lamblin, R. Pascanu, O. Delalleau, G. Desjardins, D. Warde-Farley, I. Goodfellow, A. Bergeron, et al., Theano: Deep learning on gpus with python, in: NIPS 2011, BigLearning Workshop, Granada, Spain, 3, Microtome Publishing., 2011, pp. 1–48.
- [163] C. Schaffer, Selecting a classification method by cross-validation, *Mach. Learn.* 13 (1) (1993) 135–143.
- [164] B. Zadrozny, Learning and evaluating classifiers under sample selection bias, in: Proceedings of the Twenty-First International Conference on Machine Learning, ACM, 2004, p. 114.
- [165] J. Huang, A. Gretton, K.M. Borgwardt, B. Schölkopf, A.J. Smola, Correcting sample selection bias by unlabeled data, in: Advances in Neural Information Processing Systems, 2007, pp. 601–608.
- [166] J.-G. Lee, S. Jun, Y.-W. Cho, H. Lee, G.B. Kim, J.B. Seo, N. Kim, Deep learning in medical imaging: general overview, *Korean J. Radiol.* 18 (4) (2017) 570–584.