

Wireless Connectivity and Sensorics in Hearing Instruments

by Rout Ayasakanta

Submission date: 15-Nov-2017 03:19PM (UTC+0530)

Submission ID: 880250269

File name: Paper-11.docx (88.57K)

Word count: 3446

Character count: 20381

Wireless Connectivity and Sensorics in Hearing Instruments

Ayasakanta Rout, Ph.D.

⁶
James Madison University, Harrisonburg, VA 22807

Address for Correspondence

Ayasakanta Rout

⁵
James Madison University

Department of Communication Sciences and Disorders

⁴
235 Martin Luther King Jr. Way, MSC-4304

Harrisonburg, VA 22807

USA

Phone: +1 540 429 0412

Email: routax@jmu.edu

Abstract

Wireless connectivity and sensorics are two exciting areas of research and development in hearing aids. In this perspective article, currently available wireless technologies (near field magnetic induction and radio frequencies) are described along with advantages and limitations of each approach. Further, the future of biomechanical sensors in hearing aids and the integration of hearing aids with ear level fitness tracking devices are also discussed.

Key words: Wireless, Near Field Magnetic Induction (NFMI), 2.4 GHz, Sensorics, Hearables.

Introduction

The primary function of a hearing aid is to compensate for the hearing loss of a user by providing frequency specific amplification for different levels of sound in the environment. Established approaches such as compression, noise reduction and feedback cancellation are standard features of hearing aids today. In recent years, wireless connectivity has become an essential signal processing feature in premium and mid-level digital hearing aids. Wireless technology varies across manufacturers, but the end goal is the same - to communicate between a pair of hearing aids, and to connect with other accessories for streaming audio or exchanging data. Different approaches to wireless connectivity are described in this article by comparing the advantages and limitations of each approach.

As the existing hearing aid technology matures, there are other emerging consumer electronics technologies that are entering the field of hearing instrument design. One such technology is biomechanical sensorics which uses different sensors to detect subtle changes in the human body and use that data to adapt to the environment and provide immediate feedback to the user. The research and development for future integration of sensorics in hearing instruments is emerging from two different areas: hearing aid manufactures and consumer electronics and wearable fitness tracking companies. Hearing aid manufacturers are working on creating hearing aids that can integrate sensors within the ear canal and the hearing aid itself. Such a device can potentially provide useful value added service to the patient. For example, by integrating accelerometers to the hearing aid, we can detect if an elderly person falls. Further, if that hearing aid is wirelessly connected to a network, it can automatically send a signal to first responders for help. Similarly, manufacturers of fitness tracking devices are also migrating wrist based sensors to the ear canal. Such a device can track fitness data, provide biofeedback, and stream audio

signals (phone calls, music, and television). Additionally, that device can potentially be programmed to act as a personal hearing instrument. As the two seemingly separate fields develop these new devices, there is an anticipation of mergers and collaborations between manufacturers of hearing aids and consumer electronics. These wearable fitness tracking devices that can help a person hear better are categorized under a broad term “hearables”. In the second half of this article a description of the available hearable devices and their sensorics will be presented.

Wireless Connectivity in Hearing Aids

Wireless technology has been in existence in our field for a long time including Induction Loop, Frequency Modulation (FM) and Infrared systems. In recent years, newer wireless protocols such as Bluetooth, proprietary radio frequencies, and near field magnetic induction (NFMI) have been introduced as the transmission signal of choice in hearing aids. These new wireless technologies have changed the way hearing aids communicate with each other in a pair, and with other devices such as smart phones and external audio sources. Figure 1 shows the functional block diagram of a digital hearing aid with wireless functionality. The wireless antenna is built into the hearing aid and it communicates with the DSP chip. Currently available wireless technology can be classified in two categories based on the distance within which they can transmit the signal: near-field and far-field transmission.

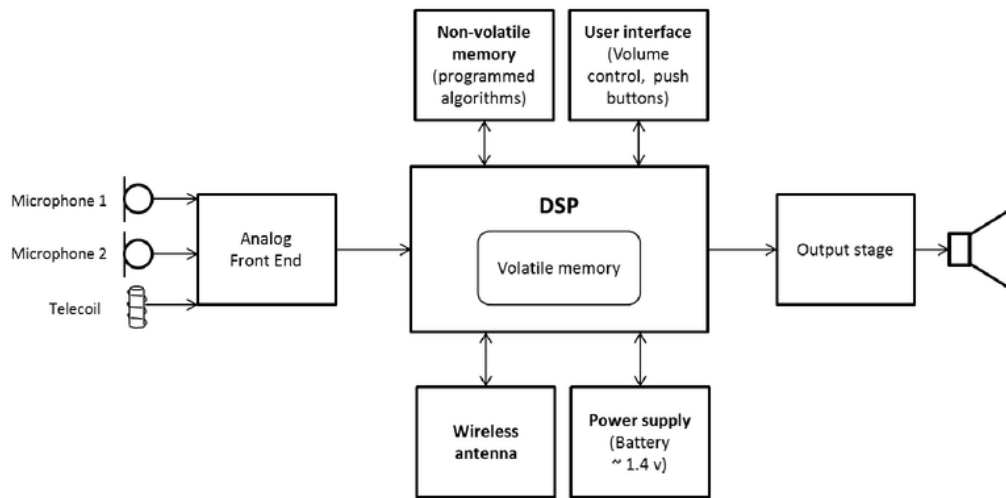

Figure 1. Main functional components of a digital hearing aid shown with wireless antenna. Adapted from ON semiconductors (2014).

Near-field refers to short transmission distances (typically less than 1 meter). These wireless systems are based on Near Field Magnetic Induction (NFMI). ³ NFMI is easy to implement in hearing instruments, as the technology is similar to telecoil. There is no need to develop specially designed antennae to implement NFMI technology. This is the primary reason hearing aid manufacturers adopted NFMI as the wireless technology in the beginning. There are limitations to this approach. Since the near-field signal can only travel up to 1 meter, it is not possible to wirelessly communicate across greater distances such as receiving direct audio signal from the TV. Therefore hearing aids using NFMI technology must also use an intermediate gateway device to communicate with distant sources. The gateway device communicates with the audio source (e.g. TV adapter) via Bluetooth technology and translates the Bluetooth signal into electromagnetic signal. This electromagnetic signal is broadcasted by the loop of the gateway device which is typically worn around the patient's neck. The NFMI antenna inside the

hearing aid picks up the magnetic signal similar to the principle in which induction loop systems work. The transmission frequency in NFMI systems falls in the range of 10-14 MHz.

The main advantage of an NFMI system is the ease with which it can be implemented and its low power consumption. Another advantage is with communication between a pair of hearing aids (left and right side). Since the transmission frequency is relatively low, the signal can go around the head with relative ease and the two hearing aids can maintain communication. A pair of hearing aids exchanges data at a fast rate to synchronize several parameters between the two hearing aids. Despite these advantages NFMI wireless systems have two primary limitations. First, the gateway device is an additional piece of equipment that some patients might object to wearing. Second, Bluetooth protocol can result in significant transmission delays often ranging from 40-125 milliseconds. Longer audio delays can potentially introduce audio-video asynchrony while watching television.

Far-field wireless technology uses radio frequencies (RF) to broadcast signals over a longer distance, typically 7 – 9 meters (23 – 30 feet). This eliminates the need for a gateway device around the patient's neck. Since there is no intermediary device and no need for translating one coding language to another, the transmission delay from the sound source (e.g. TV) to the hearing aid is minimal.

Different radio frequencies can be used to broadcast the signal. Standard protocols in the United States use 900 MHz RF to broadcast while the European Union uses 868 MHz. This is problematic on two counts: compatibility issues for the patient and the manufacturer. Furthermore, these radio frequencies require specially designed antennae that are rather large for hearing aids. Another option is to use a universally available radio frequency. Currently, 2.4 GHz

is used by some hearing aid manufacturers to directly communicate between the hearing aid and other devices capable of communicating at that frequency. The 2.4 GHz technology has some limitations as well. Power consumption to run a 2.4 GHz radio is much higher. Therefore, the hearing aid battery life will be significantly diminished when the patients streams audio from the TV or listens music from the phone. The 2.4 GHz signal does not propagate well around the human head, making it not suitable for ear to ear communication. Advantages and limitations of NFMI and RF technologies are summarized in Table 1.

Recent innovations have resulted in hearing aids that use a dual-radio solution. This approach packs two separate antennae into a small hearing aid. Figure 2 shows the functional blocks of a hearing aid chip with separate integrated circuits (ICs) and the two radios.

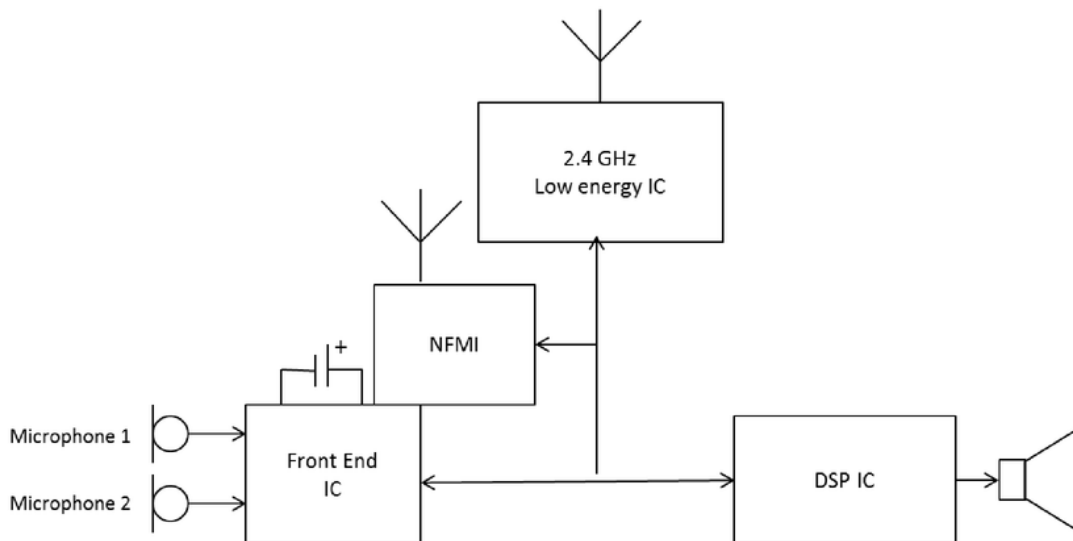

Figure 2. Functional blocks of a commercially available digital hearing aid chip (Oticon Velox) with separate integrated circuits (ICs) and the two radios (TwinLink). Adapted from Weile and Bach (2016). Copyright 2016 Oticon A/S.

Table 1. Summary of advantages and limitations of NFMI and RF technology.

	Advantages	Limitations
NFMI (hearing aid to gateway device)	<ul style="list-style-type: none"> • Ease of implementation, existing RF chips, simple antenna design • Low frequency means easier ear-to-ear communication • Low power consumption 	<ul style="list-style-type: none"> • Short transmission distance (less than 1 meter) • Requires a streaming device for all media, phone, and programming connectivity • May encounter interference with magnetic sources (cochlear implants)
Bluetooth (sound source to gateway device)	<ul style="list-style-type: none"> • Can be implemented using existing technology. No need to design special antenna within the hearing aid 	<ul style="list-style-type: none"> • Bluetooth for audio streaming introduces a delay (often > 100 milliseconds) that is likely to cause audio-video synchrony problems while watching television
RF 900/868 MHz	<ul style="list-style-type: none"> • Does not require a “Gateway device” for media connectivity • Long distance signal transmission • Relatively low power consumption • Low latency (processing delay) from source to listener • No echo problems and no lip synchronization issues when watching TV 	<ul style="list-style-type: none"> • Requires a specially designed antenna • Requires a streaming device for Bluetooth connectivity • 900 MHz band is limited to use in certain areas including US, Greenland, and some eastern Pacific Islands • 868 MHz band is limited to use in EU.

<p>RF 2.4 GHz</p>	<ul style="list-style-type: none"> • Does not require a ‘Gateway Device’ • Long distance signal transmission (up to 9 meters) • Robust and reliable connections • High transmitted data capacity: bandwidth, stereo, low distortion • Low latency (delay) • Worldwide applicable 	<ul style="list-style-type: none"> • Requires a specially designed antenna • Cannot propagate over physical barriers (e.g. human head) • Relatively high power consumption
<p>Combined NFMI and RF</p>	<ul style="list-style-type: none"> • NFMI allows better ear to ear communication • RF eliminates the need for a gateway device. 	<ul style="list-style-type: none"> • Need complex antenna design and space constraints

Hearing aids “made for iPhone”

The 2.4 GHz radio frequency allows direct communication between a hearing aid and an iPhone or any other compatible iOS device. Currently any Apple device running on iOS 7 or later platform is compatible with the made for iPhone hearing aids. The first “made for iPhone” hearing aids were introduced in 2014 by ReSound. Starkey Hearing Technology was the next manufacturer to introduce their made for iPhone hearing aids. Other manufacturers soon introduced their versions of made for iPhone hearing aids. The direct communication with iPhones opens up exciting opportunities for the hearing aid user as well as the manufacturers. Direct connection eliminates the need for accessories, and custom designed hearing aid apps allow the patient to control the hearing aid through the iPhone. A hearing aid user can benefit from direct connectivity to iPhone by:

- Audio streaming from iPhone without any intermediary device: the hearing aid user can stream music, directly connect to a phone call, or stream the audio of YouTube videos directly to the hearing aid.
- Custom hearing aid app: Apps developed by hearing aid manufacturers can be used to control and personalize the hearing aid with an iPhone.
- Finding misplaced hearing aids: the hearing aid app can help locate the hearing aids by showing a stronger signal as the two devices are brought closer to each other. If the hearing aid's battery dies or the hearing aid is turned off, the app can show the location where the hearing aid and iOS device were last connected.
- Geo-tagging: the hearing aid user can tag a geographic location (e.g. library or coffee shop) and set specific amplification settings for that location. When the user returns to that location at a later time the hearing aid automatically can engage the stored settings for that location.

The made for iPhone technology gives the hearing aid design engineers a whole new world in signal processing. The main challenges in hearing aid signal processing are imposed by the limited power supply and the small packaging of the chip. By connecting wirelessly to the iPhone, it is possible to run complex signal processing algorithms within the iPhone and send the output to the hearing aid for further processing. For example, Apple's A8 chip has 2 billion transistors compared to 65 million transistors in an advanced hearing aid. The added processing power can help implement many complex signal processing algorithms that were deemed impossible in hearing aids until now. It is also possible to make the hearing aid a part of a home network where several compatible devices are programmed to function synchronously. For example, when a hearing aid user powers up the hearing aid for the first time in the morning, it

can send a signal to a compatible coffee maker within the home network to start brewing coffee. With the advent of new technologies, it is quite possible to see more innovations in the area of connectivity.

Sensorics in Hearable Devices

The term sensorics in hearables can be defined as application of biomechanical sensors to collect personal health and fitness data at the level of the ear. In wearable fitness tracking devices the wrist is used as a preferred location to collect health data. By placing sensors on the wrist these devices can measure pulse rate, body temperature, and movement related information. However, the data collected from the wrist is not reliable and can result in many artifacts due to movement of the hand (Ledger, 2014). Furthermore, recent reports indicate that one-third of users stop using their wearables within six months of owning a device, and half of all wearable users stop engaging with their devices in the long-term (Nguyen, 2016). As a result, many consumer electronics companies have begun integrating the wrist level sensors into their earbuds designed for music streaming. Hearing aid manufacturers are also working on adding basic amplification into these hearable devices. It is argued that if sensors can be integrated into a hearing instrument, the user is more likely to use it because the hearing instrument is a necessity for the user as opposed a wrist worn device which is an optional accessory. One such example is the partnership between the fitness tracker Bragi and the hearing aid manufacturer, Starkey. By combining their respective expertise the Bragi Dash Pro is individualized to include custom earmolds, high quality hearing aid receivers, wax guard, and custom engraving that is not currently available from other devices. The hearables market is expected to grow exponentially (Ledger, 2014). Currently several major consumer electronics companies such as Apple,

Samsung, Bose, Sony, and Motorola are introducing hearable earbuds. Other niche companies and startups such as Jabra, Nuheara, and the aforementioned Bragi have also introduced ear level devices. These devices are already equipped with directional microphones and noise reduction features. It is not far-fetched to anticipate that basic hearing aid technology (e.g. frequency specific gain and compression amplification) would be available in these devices in the near future.

Hearables are increasingly collecting a wide range of fitness tracking data including heart rate monitoring, step count, volume Oxygen level, calories, distance, and speed. Some devices are also able to provide real time spoken language translation in addition to wirelessly streaming audio from phone calls, music player, and television. A list of currently available hearable devices and their features is summarized in table 2.

Table 2. Summary of currently available hearable devices and their main features. Note that hearables from Bose, Nuheara, and Doppler labs have the option to amplify speech (akin to a personal sound amplifier). Other devices focus on audio streaming with integrated fitness sensors.

Hearable Device	Available Features
Bose Hearphones	<ul style="list-style-type: none">• Active noise cancellation• Amplifies speech• Music and TV streaming• Can be controlled with an app
Samsung Gear IconX earbuds	<ul style="list-style-type: none">• Active noise cancellation• Voice recognition• Wireless connectivity and audio streaming• Analyzes exercise and fitness data• No sound amplification
Bragi Dash Pro tailored by Starkey	<ul style="list-style-type: none">• Custom fit with an ear impression• Active noise cancellation

	<ul style="list-style-type: none"> • Voice recognition • Wireless connectivity and audio streaming • Analyzes exercise and fitness data • No sound amplification
Jabra Elite Sport earbuds	<ul style="list-style-type: none"> • Wireless streaming • Can mix environmental sounds with streamed audio • Fitness analysis (heart rate, volume Oxygen level, rep count) • No sound amplification
Nuheara IQbuds	<ul style="list-style-type: none"> • Audio streaming • Active noise cancellation • Speech amplification • Can mix environmental sounds with streamed audio • Can be controlled with an app • No biometric fitness data analysis
Motorola Moto Hint earbuds	<ul style="list-style-type: none"> • Audio streaming • Can mix environmental sounds with streamed audio • Can be controlled with an app • No biometric fitness data analysis
Sony Xperia Ear	<ul style="list-style-type: none"> • Voice activated and gesture enabled control • Wireless streaming • Active noise cancellation • Audio notifications from calendar appointments
Apple Airpods	<ul style="list-style-type: none"> • Voice activated controls • Wireless streaming • Active noise cancellation • No biometric fitness data analysis • No speech amplification
Doppler Labs Here One smart earbuds* (Doppler labs closed their operation in October 2017)	<ul style="list-style-type: none"> • Wireless streaming • Active noise cancellation • Controlled by an app • Personalized amplification based on hearing profile

Conclusion

As disruptive innovations enter the field of hearing aid design, the function of a hearing aid as we know it will change. We may see two classes of hearing devices. First category may include hearing aids that can incorporate various sensors to improve listening in complex situations and measure physiologic data to track certain aspects of the hearing aid user's health. A second category of hearables may include ear level audio streaming devices with amplification and fitness tracking. These new categories of hearables are going to impact our current models of audiologic practice. Are you ready for these changes?

References

1. Ledger, D. (2014). Inside wearables – part 2. Endeavour Partners white paper, Retrieved on Oct 18, 2017 from <https://blog.endeavour.partners/inside-wearables-part-2-july-2014-ef301d425cdd>.
2. Nguyen, C. (2016). Bragi on what the ear means for the future of wearables. Wearables, Retrieved on November 1, 2017 from <https://www.wearable.com/hearables/bragi-starkey-hearables-future-of-wearables>.
3. ON Semiconductor (2014). Solving the hearing aid platform puzzle: seven things hearing aid manufacturers should think about [Technical note # TND6092/D]. Retrieved Jun 10, 2016, from <http://www.onsemi.com/pub/Collateral/TND6092-D.PDF>.
4. Weile, J.N. and Bach, R. (2016). The Velox™ platform [technical white paper]. Retrieved Dec 11, 2016, from <http://www.oticon.global/professionals/evidence>.

Table 1. Summary of advantages and limitations of NFMI and RF technology.

	Advantages	Limitations
NFMI (hearing aid to gateway device)	<ul style="list-style-type: none"> • Ease of implementation, existing RF chips, simple antenna design • Low frequency means easier ear-to-ear communication • Low power consumption 	<ul style="list-style-type: none"> • Short transmission distance (less than 1 meter) • Requires a streaming device for all media, phone, and programming connectivity • May encounter interference with magnetic sources (cochlear implants)
Bluetooth (sound source to gateway device)	<ul style="list-style-type: none"> • Can be implemented using existing technology. No need to design special antenna within the hearing aid 	<ul style="list-style-type: none"> • Bluetooth for audio streaming introduces a delay (often > 100 milliseconds) that is likely to cause audio-video synchrony problems while watching television
RF 900/868 MHz	<ul style="list-style-type: none"> • Does not require a “Gateway device” for media connectivity • Long distance signal transmission • Relatively low power consumption • Low latency (processing delay) from source to listener • No echo problems and no lip synchronization issues when watching TV 	<ul style="list-style-type: none"> • Requires a specially designed antenna • Requires a streaming device for Bluetooth connectivity • 900 MHz band is limited to use in certain areas including US, Greenland, and some eastern Pacific Islands • 868 MHz band is limited to use in EU.
RF 2.4 GHz	<ul style="list-style-type: none"> • Does not require a ‘Gateway Device’ • Long distance signal transmission (up to 9 meters) • Robust and reliable connections • High transmitted data capacity: bandwidth, stereo, low distortion • Low latency (delay) • Worldwide applicable 	<ul style="list-style-type: none"> • Requires a specially designed antenna • Cannot propagate over physical barriers (e.g. human head) • Relatively high power consumption
Combined NFMI and RF	<ul style="list-style-type: none"> • NFMI allows better ear to ear communication • RF eliminates the need for a gateway device. 	<ul style="list-style-type: none"> • Need complex antenna design and space constraints

Table 2. Summary of currently available hearable devices and their main features. Note that hearables from Bose, Nuheara, and Doppler labs have the option to amplify speech (akin to a personal sound amplifier). Other devices focus on audio streaming with integrated fitness sensors.

Hearable Device	Available Features
Bose Hearphones	<ul style="list-style-type: none"> • Active noise cancellation • Amplifies speech • Music and TV streaming • Can be controlled with an app
Samsung Gear IconX earbuds	<ul style="list-style-type: none"> • Active noise cancellation • Voice recognition • Wireless connectivity and audio streaming • Analyzes exercise and fitness data • No sound amplification
Bragi Dash Pro tailored by Starkey	<ul style="list-style-type: none"> • Custom fit with an ear impression • Active noise cancellation • Voice recognition • Wireless connectivity and audio streaming • Analyzes exercise and fitness data • No sound amplification
Jabra Elite Sport earbuds	<ul style="list-style-type: none"> • Wireless streaming • Can mix environmental sounds with streamed audio • Fitness analysis (heart rate, volume Oxygen level, rep count) • No sound amplification
Nuheara IQbuds	<ul style="list-style-type: none"> • Audio streaming • Active noise cancellation • Speech amplification • Can mix environmental sounds with streamed audio • Can be controlled with an app • No biometric fitness data analysis
Motorola Moto Hint earbuds	<ul style="list-style-type: none"> • Audio streaming • Can mix environmental sounds with streamed audio • Can be controlled with an app • No biometric fitness data analysis
Sony Xperia Ear	<ul style="list-style-type: none"> • Voice activated and gesture enabled control • Wireless streaming • Active noise cancellation • Audio notifications from calendar appointments
Apple Airpods	<ul style="list-style-type: none"> • Voice activated controls • Wireless streaming • Active noise cancellation • No biometric fitness data analysis • No speech amplification
Doppler Labs Here One smart earbuds* (Doppler labs closed their operation in October 2017)	<ul style="list-style-type: none"> • Wireless streaming • Active noise cancellation • Controlled by an app • Personalized amplification based on hearing profile

Wireless Connectivity and Sensorics in Hearing Instruments

ORIGINALITY REPORT

4%

SIMILARITY INDEX

3%

INTERNET SOURCES

1%

PUBLICATIONS

0%

STUDENT PAPERS

PRIMARY SOURCES

1

yourhearingloss.org

Internet Source

2%

2

gnresoundblog.com

Internet Source

1%

3

Kim, Jin Sook, and Chun Hyeok Kim. "A Review of Assistive Listening Device and Digital Wireless Technology for Hearing Instruments", Korean Journal of Audiology, 2014.

Publication

<1%

4

Christopher G. Clinard, Sarah L. Hodgson, Mary Ellen Scherer. "Neural Correlates of the Binaural Masking Level Difference in Human Frequency-Following Responses", Journal of the Association for Research in Otolaryngology, 2016

Publication

<1%

5

Watts, Christopher R.. "The Voice and Voice Therapy, 7th ed.(Book Review)", Journal of Medical Speech - Language Pat, Dec 2005 Issue

<1%

6

Cynthia O'Donoghue, Elizabeth Nottingham.
"Dysphagia Management in the Schools: Past,
Present, and Future", Seminars in Speech and
Language, 2017

<1%

Publication

Exclude quotes On

Exclude matches < 7 words

Exclude bibliography On